

## COMPREHENSIVE SERVICES

We offer competitive repair and calibration services, as well as easily accessible documentation and free downloadable resources.

## SELL YOUR SURPLUS

We buy new, used, decommissioned, and surplus parts from every NI series. We work out the best solution to suit your individual needs.

 Sell For Cash    Get Credit    Receive a Trade-In Deal

## OBSOLETE NI HARDWARE IN STOCK & READY TO SHIP

We stock **New**, **New Surplus**, **Refurbished**, and **Reconditioned** NI Hardware.



*Bridging the gap between the manufacturer and your legacy test system.*

 1-800-915-6216

 [www.apexwaves.com](http://www.apexwaves.com)

 [sales@apexwaves.com](mailto:sales@apexwaves.com)

*All trademarks, brands, and brand names are the property of their respective owners.*

**Request a Quote**

 **CLICK HERE**

**SH68F-68F-EPM**

CUSTOMER DRAWING COMPATIBILITY			
REV	DESCRIPTION	DATE	APPROVED
A	DRAWING COMPATIBLE, OBSOLETE		
B	DRAWING COMPATIBLE, RELEASED		

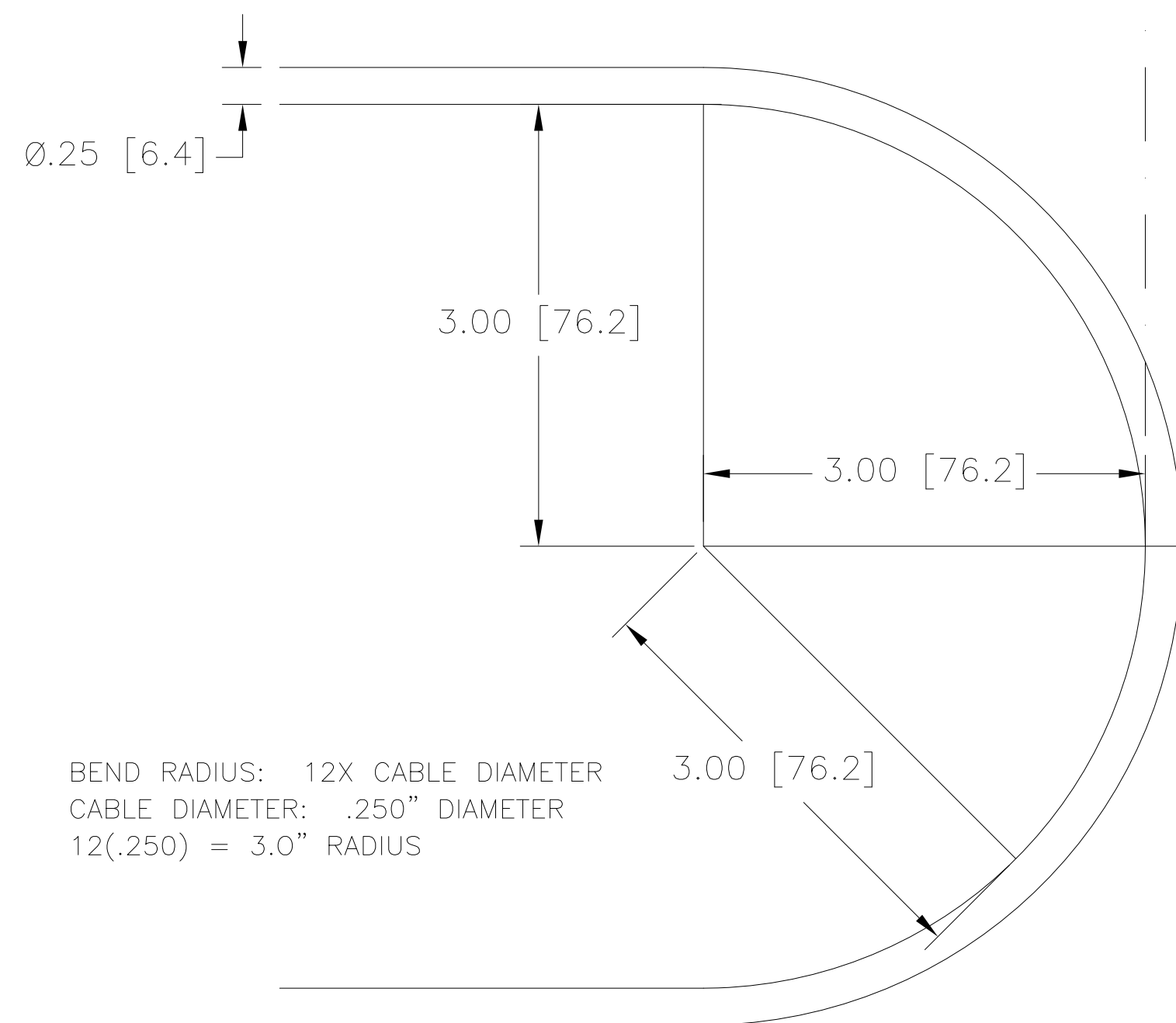
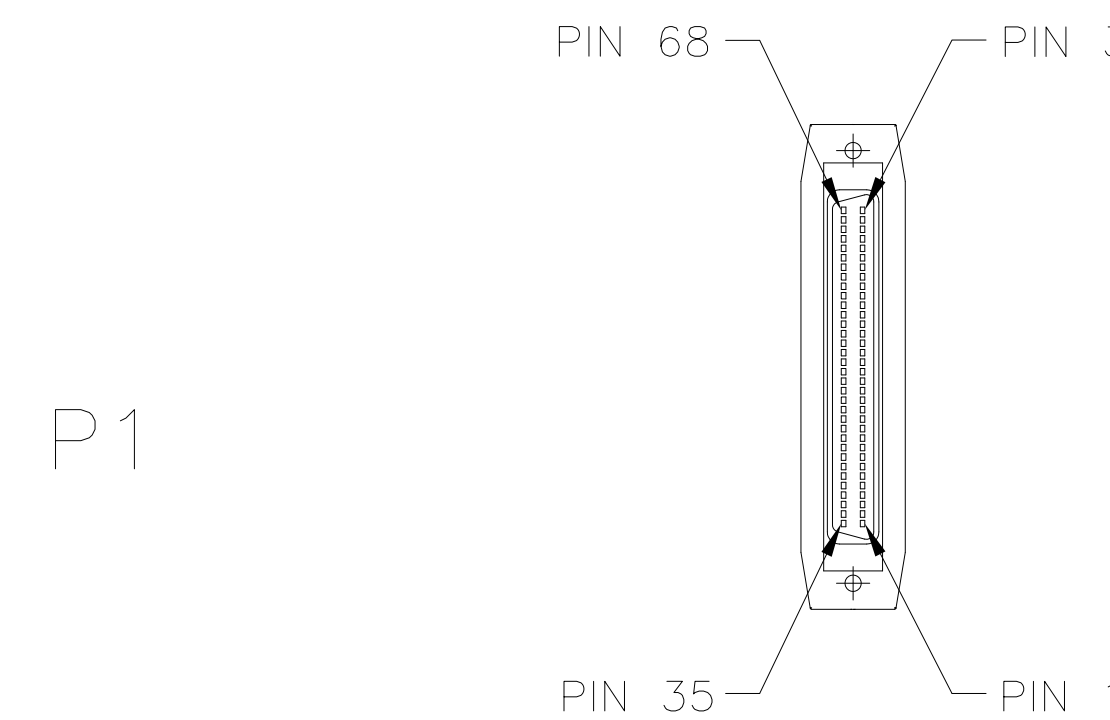
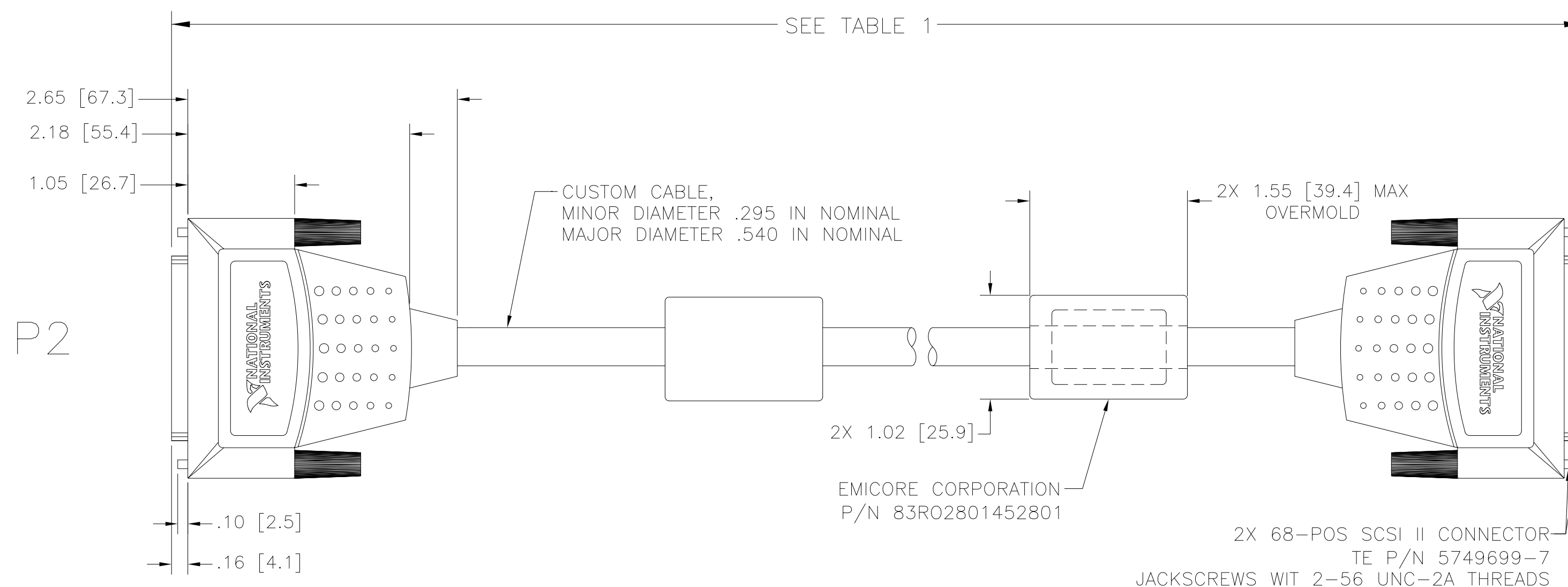
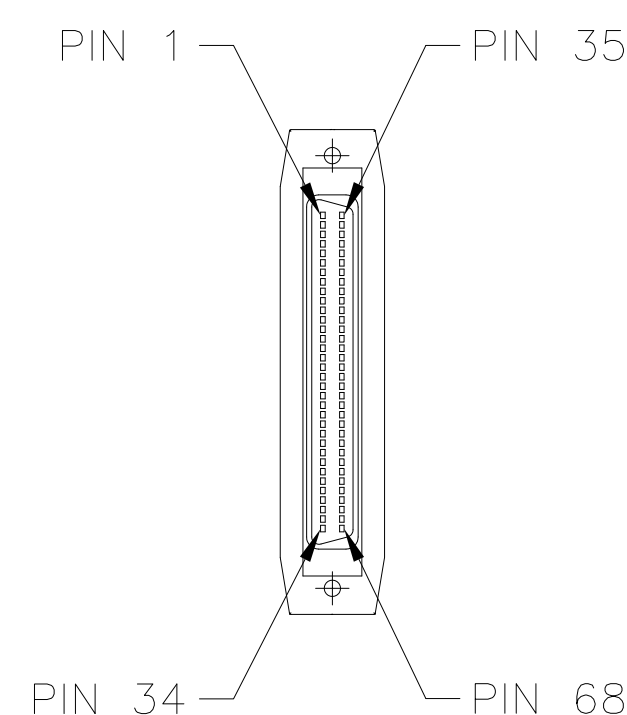

BEND RADIUS EXAMPLE

WIRE LIST		
P1 .050	CABLE	P2 .050
PIN NO	COLOR CODE	PIN NO
65	WHITE/BLACK	65
31	BLACK/WHITE	31
64	SHIELD 1	64
63	WHITE/BROWN	63
30	BROWN/WHITE	30
29	SHIELD 2	29
57	WHITE/RED	57
23	RED/WHITE	23
56	SHIELD 3	56
68	WHITE/ORANGE	68
34	ORANGE/WHITE	34
67	SHIELD 4	67
66	WHITE/GREEN	66
33	GREEN/WHITE	33
32	SHIELD 5	32
58	WHITE/BLUE	58
25	BLUE/WHITE	25
24	SHIELD 6	24
60	WHITE/VIOLET	60
26	VIOLET/WHITE	26
59	SHIELD 7	59
61	WHITE/GRAY	61
28	GRAY/WHITE	28
27	SHIELD 8	27
22	BROWN/BLACK	22
54	BLACK/BROWN	54
21	RED/BLACK	21
55	BLACK/RED	55
62	WHITE/YELLOW	62
20	RED/BLUE	20
54	CORE SHIELD	54

WIRE LIST (CONT.)		
P1 .050	CABLE	P2 .050
PIN NO	COLOR CODE	PIN NO
53	BLACK/VIOLET	53
19	VIOLET/BLACK	19
52	BLACK/BLUE	52
18	BLUE/BLACK	18
51	BLUE/GREEN	51
18	GREEN/BLUE	18
50	BLACK/GREEN	50
17	GREEN/BLACK	17
50	VIOLET/ORANGE	50
16	ORANGE/VIOLET	16
49	BLACK/YELLOW	49
15	YELLOW/BLACK	15
48	GRAY/RED	48
15	RED/GRAY	15
47	YELLOW/ORANGE	47
13	ORANGE/YELLOW	13
46	BLACK/ORANGE	46
13	ORANGE/BLACK	13
45	BROWN/GRAY	45
12	GRAY/BROWN	12
44	RED/ORANGE	44
11	ORANGE/RED	11
44	PINK/BLACK	44
10	BLACK/PINK	10
43	BROWN/VIOLET	43
9	VIOLET/BROWN	9
42	BROWN/BLUE	42
9	BLUE/BROWN	9
41	RED/YELLOW	41
7	YELLOW/RED	7
40	YELLOW/GREEN	40
7	GREEN/YELLOW	7
35	BROWN/GREEN	35
6	GREEN/BROWN	6
39	BROWN/YELLOW	39
7	YELLOW/BROWN	7
4	ORANGE/GREEN	4
5	GREEN/ORANGE	5
38	BROWN/ORANGE	38
4	ORANGE/BROWN	4
37	YELLOW/BLUE	37
4	BLUE/YELLOW	4
36	ORANGE/BLUE	36
3	BLUE/ORANGE	3
36	BROWN/RED	36
2	RED/BROWN	2
35	BLACK/GRAY	35
1	GRAY/BLACK	1
8	ORANGE/GRAY	8
14	VIOLET/RED	14
SHELL		SHELL

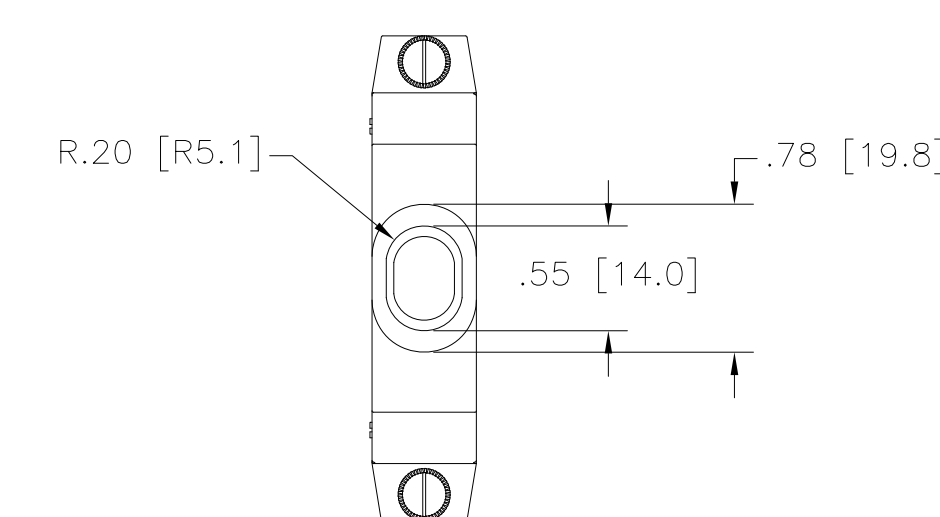
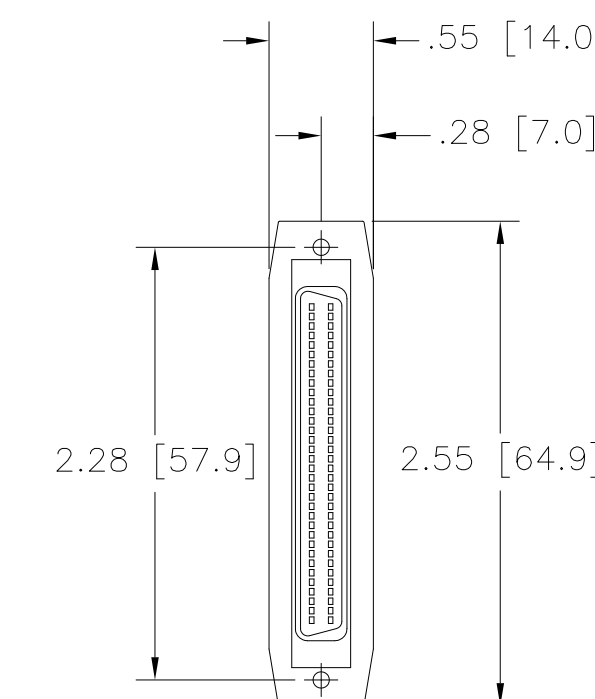

TABLE 1	
LENGTH	TOLERANCE
<2M	+5 CM/-0 CM
2 TO 5M	+10 CM/-0 CM
>5M	+15 CM/-0 CM

CONDUCTOR SPECIFICATIONS

CONDUCTOR: 30AWG 7/38 TIN PLATED COPPER, .012 INCH DIAMETER  
INSULATION: .006 INCHES OF POLYPROPYLENE, .024 INCH DIAMETER

CONDUCTOR: 26AWG 7/34 TIN PLATED COPPER, .019 INCH DIAMETER  
INSULATION: .006 INCHES OF POLYPROPYLENE, .031 INCH DIAMETER

BEND RADIUS: 12X CABLE DIAMETER (SEE EXAMPLE) PER SPECIFICATIONS  
2014 NEC SECTION 300.34 CONDUCTOR BEND RADIUS  
2014 NEC SECTION 300.24 BENDING RADIUS

1. REFER TO PRODUCT MANUAL ON NI.COM FOR MORE DETAILS.

NOTES: UNLESS OTHERWISE SPECIFIED.

CUSTOMER DRAWING

UNLESS OTHERWISE SPECIFIED DIMENSIONS ARE IN INCHES AND [MILLIMETERS]		
	AUSTIN, TEXAS	
DO NOT SCALE DRAWING THIRD ANGLE PROJECTION	TITLE SH68-68-EPM	
	SIZE	DRAWING NO.
	D 7U296	09/13/16
SCALE: 1/1	SHEET 1 OF 1	