

COMPREHENSIVE SERVICES

We offer competitive repair and calibration services, as well as easily accessible documentation and free downloadable resources.

SELL YOUR SURPLUS

We buy new, used, decommissioned, and surplus parts from every NI series. We work out the best solution to suit your individual needs.

 Sell For Cash  Get Credit  Receive a Trade-In Deal

OBSOLETE NI HARDWARE IN STOCK & READY TO SHIP

We stock **New**, **New Surplus**, **Refurbished**, and **Reconditioned** NI Hardware.



Bridging the gap between the manufacturer and your legacy test system.

 1-800-915-6216

 www.apexwaves.com

 sales@apexwaves.com

All trademarks, brands, and brand names are the property of their respective owners.

Request a Quote

 **CLICK HERE**

SHC68-68-RDIO

NI 9151

CompactRIO R Series Expansion System

Figure 1. NI 9151 Front Panel

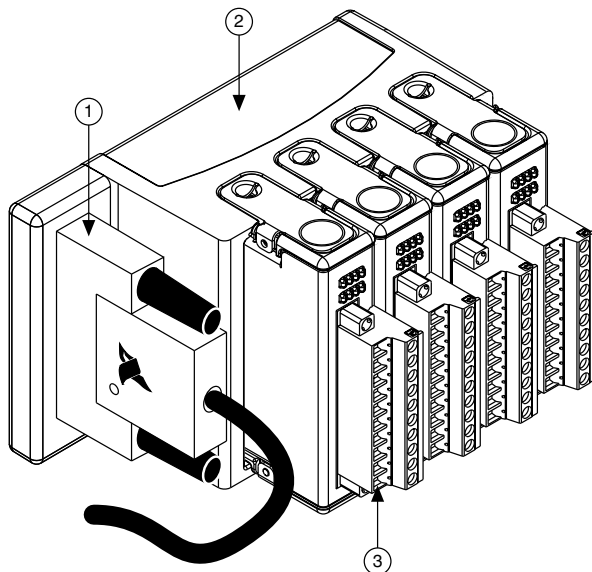

1. Cable
2. R Series Expansion Chassis
3. I/O Module

This document contains installation instructions and specifications for the NI 9151.

Safety Guidelines



Caution Do not operate the NI 9151 in a manner not specified in this document. Product misuse can result in a hazard. You can compromise the safety protection built into the product if the product is damaged in any way. If the product is damaged, return it to NI for repair.

Safety Guidelines for Hazardous Locations

The NI 9151 is suitable for use in Class I, Division 2, Groups A, B, C, D, T4 hazardous locations; Class I, Zone 2, AEx nA IIC T4 and Ex nA IIC T4 hazardous locations; and nonhazardous locations only. Follow these guidelines if you are installing the NI 9151 in a potentially explosive environment. Not following these guidelines may result in serious injury or death.



Caution Do not disconnect I/O-side wires or connectors unless power has been switched off or the area is known to be nonhazardous.



Caution Do not remove modules unless power has been switched off or the area is known to be nonhazardous.



Caution Substitution of components may impair suitability for Class I, Division 2.



Caution For Division 2 and Zone 2 applications, install the system in an enclosure rated to at least IP54 as defined by IEC/EN 60079-15.

Special Conditions for Hazardous Locations Use in Europe and Internationally

The NI 9151 has been evaluated as Ex nA IIC T4 Gc equipment under DEMKO Certificate No. 03 ATEX 0324020X and is IECEx UL 14.0089X certified. Each device is marked  II 3G and is suitable for use in Zone 2 hazardous locations, in ambient temperatures of $-40\text{ }^{\circ}\text{C} \leq T_a \leq 70\text{ }^{\circ}\text{C}$.



Caution You must make sure that transient disturbances do not exceed 140% of the rated voltage.



Caution The system shall only be used in an area of not more than Pollution Degree 2, as defined in IEC 60664-1.



Caution The system shall be mounted in an ATEX/IECEx-certified enclosure with a minimum ingress protection rating of at least IP54 as defined in IEC/EN 60079-15.



Caution The enclosure must have a door or cover accessible only by the use of a tool.

Electromagnetic Compatibility Guidelines

This product was tested and complies with the regulatory requirements and limits for electromagnetic compatibility (EMC) stated in the product specifications. These requirements and limits provide reasonable protection against harmful interference when the product is operated in the intended operational electromagnetic environment.

This product is intended for use in industrial locations. However, harmful interference may occur in some installations, when the product is connected to a peripheral device or test object, or if the product is used in residential or commercial areas. To minimize interference with radio and television reception and prevent unacceptable performance degradation, install and use this product in strict accordance with the instructions in the product documentation.

Furthermore, any changes or modifications to the product not expressly approved by National Instruments could void your authority to operate it under your local regulatory rules.

Special Conditions for Marine Applications

Some products are Lloyd's Register (LR) Type Approved for marine (shipboard) applications. To verify Lloyd's Register certification for a product, visit ni.com/certification and search for the LR certificate, or look for the Lloyd's Register mark on the product.



Caution In order to meet the EMC requirements for marine applications, install the product in a shielded enclosure with shielded and/or filtered power and input/output ports. In addition, take precautions when designing, selecting, and installing measurement probes and cables to ensure that the desired EMC performance is attained.

What You Need to Install the NI 9151

- The NI 9151 shipping kit, which includes the following components:
 - NI 9151 expansion chassis
 - NI-RIO Device Driver CD



Note NI-RIO 1.1 is the earliest supported driver for the NI 9151.

- A host computer running Windows, with NI software installed in the following order:
 - LabVIEW
 - LabVIEW FPGA
 - NI R Series Multifunction RIO Device Drivers
 - NI CompactRIO Device Drivers



Note Visit ni.com/info and enter the Info Code `rdsoftwareversion` to determine which software versions you need to use the NI 9151 and supported cRIO modules. LabVIEW 7.1, LabVIEW RT 7.1, and LabVIEW FPGA 7.1 are the earliest supported software versions for the NI 9151.

- CompactRIO I/O modules
- Installed R Series device
- SHC68-68-RDIO
- DIN rail mount kit (for DIN rail mounting only)
- Two M4 or number 10 panhead screws (for panel mounting only)
- Number 2 Phillips screwdriver
- 1/8 in. flathead screwdriver

Mounting the CompactRIO R Series Expansion Chassis

You can mount the chassis in any orientation on a 35 mm DIN rail or on a panel. Use the DIN rail mounting method if you already have a DIN rail configuration or if you need to be able to quickly remove the CompactRIO chassis. Use the panel mount method for high shock and vibration applications.



Caution Your installation must meet the following requirements for space and cabling clearance:

- Allow 25.4 mm (1 in.) on the top and the bottom of the chassis for air circulation.
- Allow 50.8 mm (2 in.) in front of modules for cabling clearance.

Figure 2. NI 9151 Bottom View with Dimensions

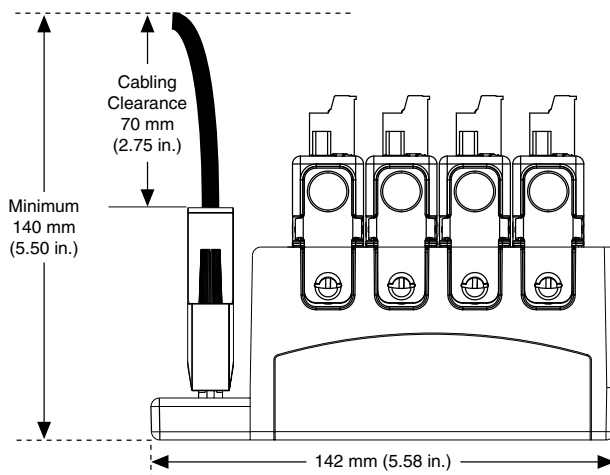
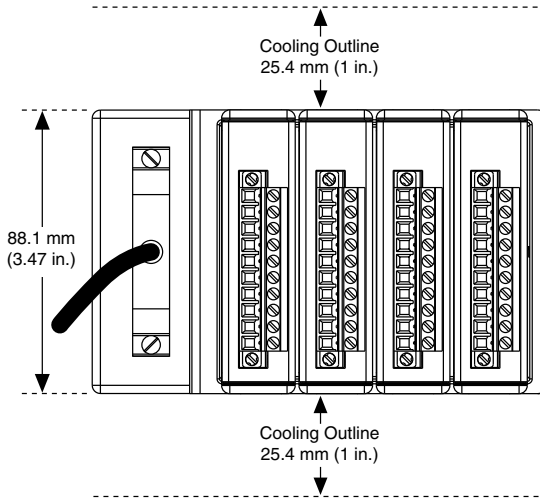

Figure 3. NI 9151 Side View with Dimensions



The following sections give instructions for the mounting methods. Before using any of these mounting methods, record the serial number from the back of the chassis. You will be unable to read the serial number after you have mounted the chassis.



Caution Before you mount the chassis, make sure the cable is not connected to the chassis.

Mounting the Chassis on a DIN Rail

You can order the NI 9912 DIN rail mount kit if you want to mount the NI 9151 on a DIN rail. You need one clip for mounting the chassis on a standard 35 mm DIN rail. Complete the following steps to mount the chassis on a DIN rail.

1. Fasten the DIN rail clip to the chassis using a number 2 Phillips screwdriver and two $M4 \times 16$ screws. NI provides these screws with the DIN rail mount kit.

Figure 4. Installing the DIN Rail Clip on the NI 9151

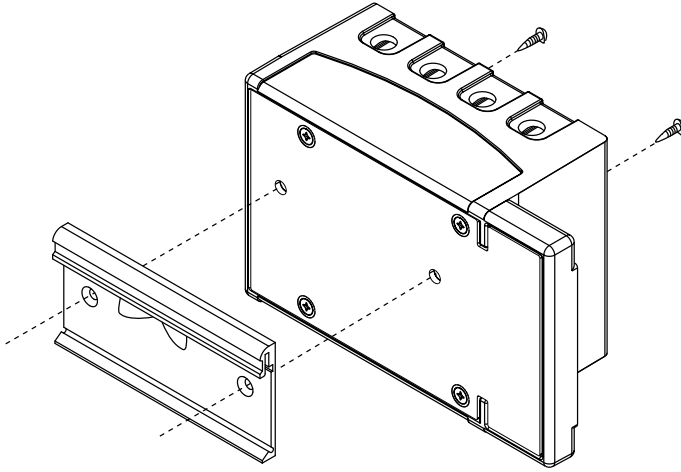

2. Insert one edge of the DIN rail into the deeper opening of the DIN rail clip.

Figure 5. One Edge of the DIN Rail Inserted in a Clip

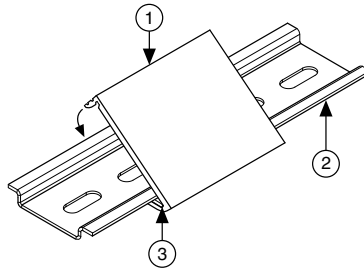

1. DIN Rail Clip
2. DIN Rail
3. DIN Rail Spring

3. Press down firmly on the chassis to compress the spring until the clip locks in place on the DIN rail.



Caution Disconnect the cable from the chassis before removing the chassis from the DIN rail.

Mounting the Chassis on a Panel

You can mount the chassis on any material if the ambient temperature is 65 °C or less. If the ambient temperature is 66 °C to 70 °C, you must mount the chassis on a thermally conductive material. Measure the ambient temperature 50.8 mm (2 in.) from the end of the chassis.

Complete the following steps to mount the chassis on a panel.

1. Align the chassis on the panel.
2. Bolt or screw the chassis to a panel using two M4 or number 10 panhead screws. NI does not provide the screws with the chassis.

Figure 6. Mounting the NI 9151 on a Panel

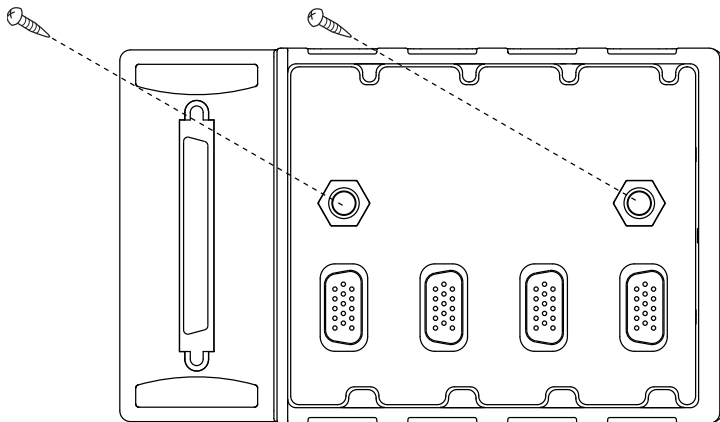

Caution Disconnect the cable from the chassis before removing the chassis from the panel.

Installing C Series I/O Modules in the Chassis

Complete the following steps to install a C Series I/O module in the chassis.

1. Make sure that no I/O-side power is connected to the I/O module. If the system is in a nonhazardous location, the chassis power can be on when you install I/O modules.
2. Align the I/O module with an I/O module slot in the chassis. The module slots are labeled 1 to 4, left to right.

Figure 7. Installing an I/O Module in the Chassis

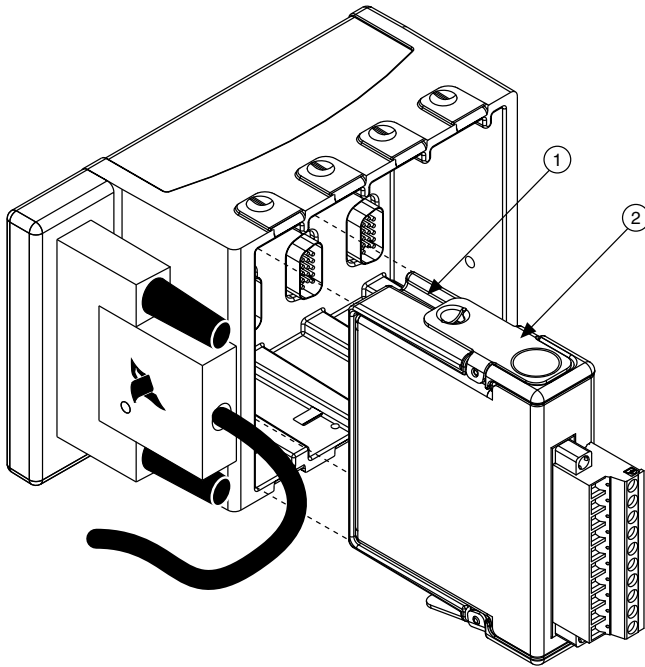

1. Insertion Groove
2. Latch

3. Squeeze the latches and insert the I/O module into the module slot.
4. Press firmly on the connector side of the I/O module until the latches lock the I/O module into place.
5. Repeat these steps to install additional I/O modules.

Removing I/O Modules from the Chassis

Complete the following steps to remove a C Series I/O module from the chassis.

1. Make sure that no I/O-side power is connected to the I/O module.
2. Squeeze the latches on both sides of the module and pull the module out of the chassis.

Connecting I/O Modules to Field Devices

Refer to the Getting Started Guide on ni.com/manuals for each I/O module.

Connecting the Chassis to Earth Ground

You must connect the green panhead screw at the end of the chassis to ground. If you are using shielded cables for the I/O module wiring, you can connect the shield to the panhead screw.

Figure 8. Connecting the Chassis to Earth Ground

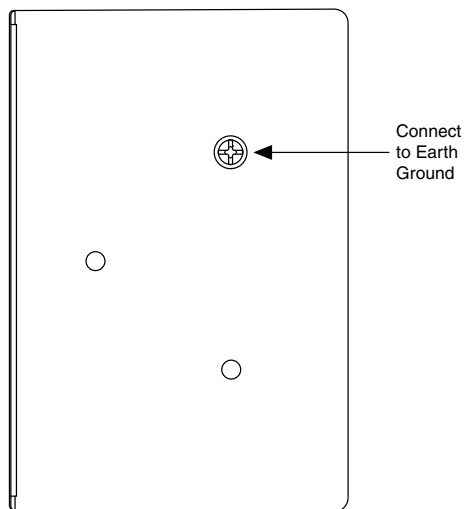

Connecting the Chassis to the R Series Device

Using a SHC68-68-RDIO cable, connect the R Series expansion chassis to the R Series device.

Where to Go Next

You have completed installing the CompactRIO hardware. Now you need to configure the I/O modules and develop your program in LabVIEW. Refer to individual device documentation on ni.com/manuals and the *LabVIEW Help*.

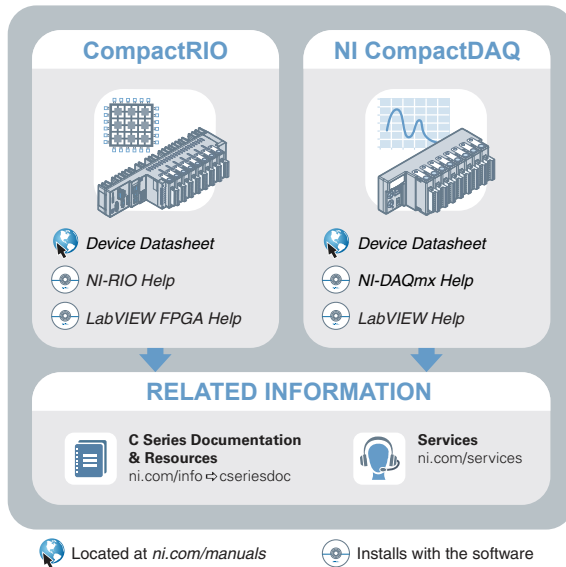

NI 9151 Specifications

The following specifications are typical for the range -40 °C to 70 °C unless otherwise noted. These specifications are for the NI 9151 expansion chassis only. For I/O module specifications, refer to the device datasheet on ni.com/manuals.



Caution Do not operate the NI 9151 in a manner not specified in this document. Product misuse can result in a hazard. You can compromise the safety protection built into the product if the product is damaged in any way. If the product is damaged, return it to NI for repair.

Power Requirements

These power requirements are for a full-loaded chassis and exclude the power requirements of the I/O modules in the chassis. Make sure your CompactPCI chassis or PXI chassis meets the power requirements for the NI 9151 and CompactRIO I/O modules. For more information about the I/O module power requirements, refer to the device datasheet on ni.com/manuals for each I/O module.

Chassis power consumption

Active mode	0.5 W maximum
Sleep mode	The NI 9151 does not support sleep mode.

Physical Characteristic

Weight (unloaded)	527 g (18.6 oz)
Dimensions (unloaded)	142 mm × 88.1 mm × 59.2 mm (5.6 in. × 3.5 in. × 2.3 in.)

Hazardous Locations

U.S. (UL)	Class I, Division 2, Groups A, B, C, D, T4; Class I, Zone 2, AEx nA IIC T4
Canada (C-UL)	Class I, Division 2, Groups A, B, C, D, T4; Class I, Zone 2, Ex nA IIC T4
Europe (ATEX) and International (IECEX)	Ex nA IIC T4 Gc

Safety and Hazardous Locations Standards

This product is designed to meet the requirements of the following electrical equipment safety standards for measurement, control, and laboratory use:

- IEC 61010-1, EN 61010-1
- UL 61010-1, CSA 61010-1
- EN 60079-0:2012, EN 60079-15:2010
- IEC 60079-0: Ed 6, IEC 60079-15; Ed 4
- UL 60079-0; Ed 5, UL 60079-15; Ed 3
- CSA 60079-0:2011, CSA 60079-15:2012



Note For UL and other safety certifications, refer to the product label or the [Online Product Certification](#) section.

Electromagnetic Compatibility

This product meets the requirements of the following EMC standards for sensitive electrical equipment for measurement, control, and laboratory use:

- EN 55011 Emissions; Group 1, Class A
- Nonindustrial levels per EN 61326-1:1997 + A2:2001, Table 1
- CE, C-Tick, and FCC Part 15 (Class A) Compliant



Note For EMC compliance, you must operate this device with shielded cabling. The device must be connected to earth ground. For more information about connecting the device to earth ground, refer to the *Connecting the Chassis to Earth Ground* section.

CE Compliance

This product meets the essential requirements of applicable European Directives, as follows:

- 2014/35/EU; Low-Voltage Directive (safety)
- 2014/30/EU; Electromagnetic Compatibility Directive (EMC)
- 94/9/EC; Potentially Explosive Atmospheres (ATEX)

Online Product Certification

Refer to the product Declaration of Conformity (DoC) for additional regulatory compliance information. To obtain product certifications and the DoC for this product, visit ni.com/certification, search by model number or product line, and click the appropriate link in the Certification column.

Shock and Vibration

To meet these specifications, you must panel mount the system.

Operating vibration

Random (IEC 60068-2-64)	5 g _{rms} , 10 Hz to 500 Hz
Sinusoidal (IEC 60068-2-6)	5 g, 10 Hz to 500 Hz
Operating shock (IEC 60068-2-27)	30 g, 11 ms half sine; 50 g, 3 ms half sine; 18 shocks at 6 orientations

Environmental

Refer to the manual for the chassis you are using for more information about meeting these specifications.

Operating temperature (IEC 60068-2-1, IEC 60068-2-2)	-40 °C to 70 °C
Storage temperature (IEC 60068-2-1, IEC 60068-2-2)	-40 °C to 85 °C
Ingress protection	IP40
Operating humidity (IEC 60068-2-78)	10% RH to 90% RH, noncondensing
Storage humidity (IEC 60068-2-78)	5% RH to 95% RH, noncondensing
Pollution Degree	2
Maximum altitude	2,000 m

Indoor use only.

Environmental Management

NI is committed to designing and manufacturing products in an environmentally responsible manner. NI recognizes that eliminating certain hazardous substances from our products is beneficial to the environment and to NI customers.

For additional environmental information, refer to the *Minimize Our Environmental Impact* web page at ni.com/environment. This page contains the environmental regulations and directives with which NI complies, as well as other environmental information not included in this document.

Waste Electrical and Electronic Equipment (WEEE)



EU Customers At the end of the product life cycle, all NI products must be disposed of according to local laws and regulations. For more information about how to recycle NI products in your region, visit ni.com/environment/weee.

电子信息产品污染控制管理办法（中国 RoHS）



中国客户 National Instruments 符合中国电子信息产品中限制使用某些有害物质指令 (RoHS)。关于 National Instruments 中国 RoHS 合规性信息，请登录 ni.com/environment/rohs_china。(For information about China RoHS compliance, go to ni.com/environment/rohs_china.)

Worldwide Support and Services

The NI website is your complete resource for technical support. At ni.com/support, you have access to everything from troubleshooting and application development self-help resources to email and phone assistance from NI Application Engineers.

Visit ni.com/services for NI Factory Installation Services, repairs, extended warranty, and other services.

Visit ni.com/register to register your NI product. Product registration facilitates technical support and ensures that you receive important information updates from NI.

A Declaration of Conformity (DoC) is our claim of compliance with the Council of the European Communities using the manufacturer's declaration of conformity. This system affords the user protection for electromagnetic compatibility (EMC) and product safety. You can obtain the DoC for your product by visiting ni.com/certification. If your product supports calibration, you can obtain the calibration certificate for your product at ni.com/calibration.

NI corporate headquarters is located at 11500 North Mopac Expressway, Austin, Texas, 78759-3504. NI also has offices located around the world. For telephone support in the United States, create your service request at ni.com/support or dial 1 866 ASK MYNI (275 6964). For telephone support outside the United States, visit the *Worldwide Offices* section of ni.com/

[niglobal](#) to access the branch office websites, which provide up-to-date contact information, support phone numbers, email addresses, and current events.

Refer to the *NI Trademarks and Logo Guidelines* at ni.com/trademarks for information on NI trademarks. Other product and company names mentioned herein are trademarks or trade names of their respective companies. For patents covering NI products/technology, refer to the appropriate location: **Help»Patents** in your software, the `patents.txt` file on your media, or the *National Instruments Patent Notice* at ni.com/patents. You can find information about end-user license agreements (EULAs) and third-party legal notices in the readme file for your NI product. Refer to the *Export Compliance Information* at ni.com/legal/export-compliance for the NI global trade compliance policy and how to obtain relevant HTS codes, ECCNs, and other import/export data. NI MAKES NO EXPRESS OR IMPLIED WARRANTIES AS TO THE ACCURACY OF THE INFORMATION CONTAINED HEREIN AND SHALL NOT BE LIABLE FOR ANY ERRORS. U.S. Government Customers: The data contained in this manual was developed at private expense and is subject to the applicable limited rights and restricted data rights as set forth in FAR 52.227-14, DFAR 252.227-7014, and DFAR 252.227-7015.

© 2003—2016 National Instruments. All rights reserved.

373560B-01 Feb16