

## COMPREHENSIVE SERVICES

We offer competitive repair and calibration services, as well as easily accessible documentation and free downloadable resources.

## SELL YOUR SURPLUS

We buy new, used, decommissioned, and surplus parts from every NI series. We work out the best solution to suit your individual needs.

 Sell For Cash    Get Credit    Receive a Trade-In Deal

## OBSOLETE NI HARDWARE IN STOCK & READY TO SHIP

We stock **New**, **New Surplus**, **Refurbished**, and **Reconditioned** NI Hardware.



*Bridging the gap between the manufacturer and your legacy test system.*

 1-800-915-6216

 [www.apexwaves.com](http://www.apexwaves.com)

 [sales@apexwaves.com](mailto:sales@apexwaves.com)

*All trademarks, brands, and brand names are the property of their respective owners.*

**Request a Quote**

 **CLICK HERE**

**SHC68-68-RDIO**

USER MANUAL

# NI 9752

NI Powertrain Controls Automotive AD Combo Module

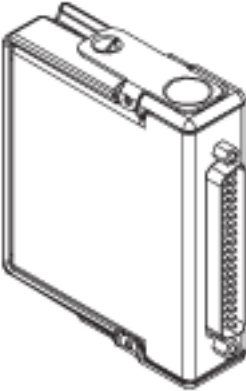

## Contents

---

|   |    |
|---|----|
| Introduction .....                                | 2  |
| Pinout .....                                      | 3  |
| Hardware .....                                    | 3  |
| Powering the Module .....                         | 3  |
| Platform Compatibility .....                      | 4  |
| Analog Inputs .....                               | 4  |
| VR Sensor Inputs .....                            | 7  |
| Hall-Effect Sensor Inputs .....                   | 9  |
| Standard Circuit Configuration .....              | 10 |
| Custom Configuration .....                        | 12 |
| Physical Specifications and Characteristics ..... | 12 |
| Compliance and Certifications .....               | 12 |

# Introduction

---

The National Instruments 9752 CompactRIO AD Combo Module includes automotive-style analog and digital inputs to interface with standard automotive sensors.

## Features

- 21 Ch. Analog inputs
  - 12-bit A/D Converter
  - 4 ksps per channel
  - Manually configurable, optional pull-up, pull-down, and divide resistors
  - Anti-aliasing filter per channel
  - Dedicated 2.5 V precision reference
- 2 Ch. VR sensor inputs
  - 60 VDC input range
  - Adaptive arming threshold
- 2 Ch. Hall-effect sensor or general purpose digital inputs
  - Digital input with inverting Schmitt trigger hysteresis
  - Short circuit protection
  - Optional pull-up, pull-down, and divide resistors
  - Analog filter for noise rejection
- Sensor power output at DB-37 connector (pins 18, 19, and 37)
  - 5 V at 100 mA

# Pinout

---

**Figure 1.** Pin Assignments NI 9752

---

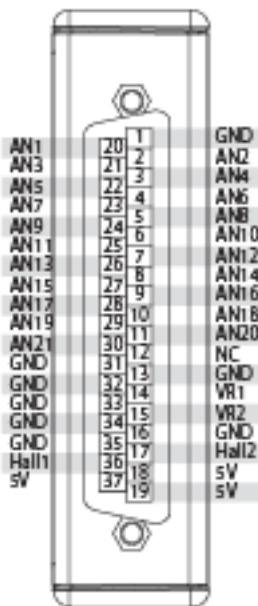

## Hardware

---

In addition to the listed analog and digital inputs, the NI 9752 provides sensor power and ground. The cRIO chassis backplane directly provides sensor power. Ensure that sensors do not draw more than a total of 100 mA.

NI recommends using the NI 9923 Connector Kit for connections to the NI 9752. The NI 9923 provides proper strain relief for NI 9752 connections. Visit [ni.com/info](http://ni.com/info) and enter Info Code ADCOMBO for more information on parts and accessories for the NI 9752.

## Powering the Module

---

The NI 9752 requires power from the CompactRIO backplane male high density D-SUB 15-pin (HD15) connector, which mates with the female HD15 connector on the module. This power source provides a regulated 5 V and ground to various digital logic and analog functions within the NI 9752. The CompactRIO 5 V source is active whenever the CompactRIO or R Series Expansion Chassis is properly powered. You can power the NI 9752 only at the HD15 connector by plugging it into a CompactRIO or R Series Expansion Chassis.



**Caution** Do not connect the HD15 connector to any other device. Do not connect 5 VDC power to the 5 V outputs of the DB-37 connector.

## Platform Compatibility

---

NI Powertrain Control modules require a hardware support system to function. You cannot use the modules independently or interfaced with third-party devices at the backplane HD15 connector. NI Powertrain Control modules are compatible with the following National Instruments platforms:

- CompactRIO, which consists of a CompactRIO controller, chassis, or integrated controller/chassis.
- NI PXI, which consists of any NI PXI chassis, NI PXI RT controller, and NI PXI-78xxR R Series FPGA card. The NI Powertrain Control modules insert into an NI R Series expansion chassis. Connect an NI R Series expansion chassis to the NI PXI FPGA card using a SHC68-68-RDIO cable.



**Note** NI Powertrain Control modules are not compatible with the National Instruments CompactDAQ chassis.

You can use NI Powertrain Control modules with NI cRIO-911x, NI cRIO-907x, and NI R Series Expansion systems under the following conditions:

- Leave one empty chassis slot between NI Powertrain Control modules and other NI modules.
- Maintain an ambient system operating temperature of 0 °C to 45 °C.



**Note** Typical specifications of National Instruments modules might not apply when used in a system with NI Powertrain Control modules.



**Note** National Instruments guarantees warranted specifications for all National Instruments modules except thermocouple modules when used in a system with NI Powertrain Control modules.



**Note** National Instruments recommends the NI 9214 for thermocouple measurements in CompactRIO systems using NI Powertrain Control modules.



**Note** NI Powertrain Control modules do not support Scan Interface mode, auto-detection, or ID mode.

## Analog Inputs

---

All analog inputs are single-ended inputs similar to production automotive ECU analog inputs and provide filtering and over/under voltage protection.

For best results, the NI 9752 must provide the power and ground of the sensors.

The standard channel configuration provides an NI-recommended pull-up or pull-down for every input to facilitate open/defective sensor faults.

# Standard Channel Configuration

## Generic Analog Input Circuit

Figure 2 shows the generic schematic representation of all analog inputs. The NI 9752 standard channel configuration includes a mixture of channel configurations according to the circuits described below.

**Figure 2.** Unconfigured Generic Analog Input Circuit Schematic

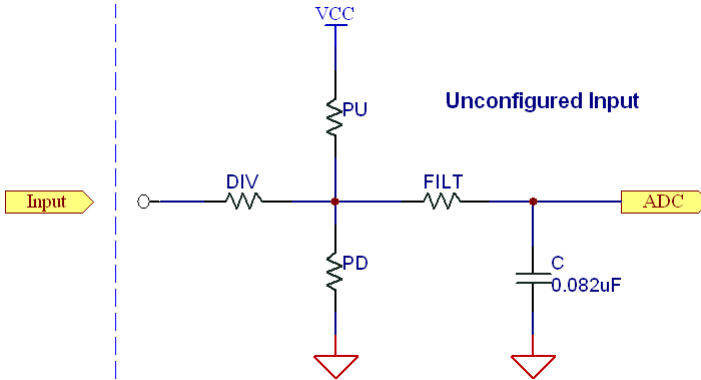

## Divided Inputs

Figure 3 shows the analog input circuit configuration for measuring voltages from 0 V to 33 V. This is standard configuration for Channels 1 through 3 in the NI 9752. Channels with this configuration are protected from voltage swings of  $\pm 50$  V.

**Figure 3.** Analog Input Configuration for 0 V to 33 V Inputs

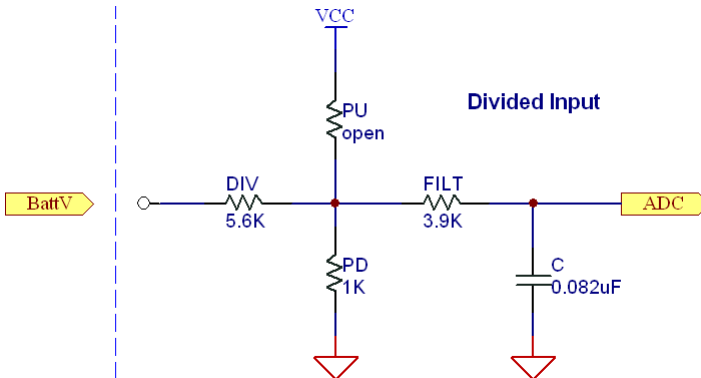

## Active Inputs / Potentiometer Inputs

Figure 4 shows the analog input circuit configuration for both active-drive analog sensors and potentiometers for measuring voltages from 0 V to 5 V. This is the standard configuration for Channels 4 through 16 in the NI 9752. Channels with this configuration are protected from voltage swings of  $\pm 30$  V.

This circuit utilizes a weak pull-down for open circuit detection. If the channel is connected to a potentiometer, the pull-down slightly modifies the voltage the A/D converter receives. You must perform a full potentiometer calibration because the voltage from this circuit does not readily correlate to the voltage resulting from an input circuit without a pull-down.

Examples of potentiometers are throttle position and pedal position sensors.

**Figure 4.** Analog Input Configuration for Active Sensors and Potentiometers

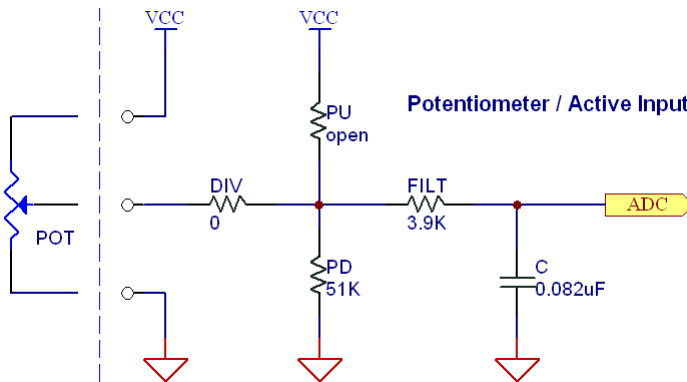

## Thermistor Inputs / Switch Inputs

Figure 5 shows the analog input circuit configuration for thermistors and switches to measure voltages from 0 V to 5 V. This is standard configuration for Channels 17 through 21 in the NI 9752. Channels with this configuration are protected from voltage swings of  $\pm 30$  V.

Thermistor inputs have a strong pull-up to create a voltage divider with the sensor. Refer to the sensor datasheet for sensor resistance curves. Most production automotive temperature sensors are thermistors with a maximum cold resistance of approximately 100 k $\Omega$  and a resistance of approximately 100  $\Omega$  at 150  $^{\circ}$ C. The pull-up resistor of 1 k $\Omega$  provides a usable output voltage range for thermistors of this type.

When used as a switch input, the switch must short to ground when it is closed.

**Figure 5.** Analog Input Configuration for Thermistors and Switches

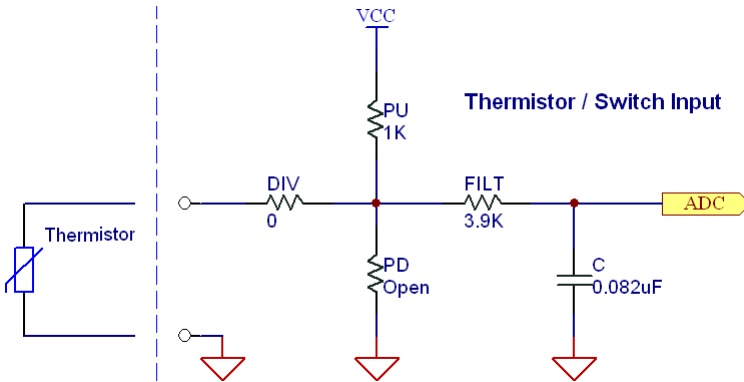

## VR Sensor Inputs

The NI 9752 provides two identical VR sensor inputs. A VR sensor input is a standard, low-cost, electromagnetic sensing device that contains a winding of wire around a permanent magnetic core. The VR sensor relies on the movement of ferrous material, or steel teeth, past the tip of the sensor to change the magnetic flux of the sensor. This movement creates a voltage pulse across the leads of the wire coil. Figures 8 and 9 show a typical VR signal with respect to toothed wheels, as shown in Figures 6 and 7. The VR signal is positive when a tooth approaches the sensor tip and then rapidly swings back through zero precisely at the center of the tooth. As the tooth moves away from the sensor tip, the voltage continues in the negative direction and then returns to zero.

The polarity of the physical tooth or gap on the trigger wheel contributes to the polarity of the voltage pulse from the sensor. Figure 6 demonstrates a positive physical tooth polarity and Figure 7 demonstrates a negative physical tooth polarity. Assuming the lead polarity of a sensor remains the same, one of the configurations generates the waveform shown in Figure 8 and the other configuration generates the waveform shown in Figure 9.

**Figure 6.** Positive Tooth Trigger Wheel





**Figure 7.** Negative Tooth Trigger Wheel

---

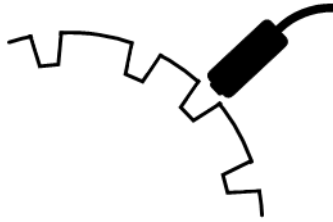

**Figure 8.** Correct Signal Polarity for VR Input Circuit

---



**Figure 9.** Incorrect Signal Polarity for VR Input Circuit

---



Each VR sensor input requires a positive sensor connection and a negative sensor connection. Connect a positive sensor input to one of the NI 9752 pins labeled VR1 and VR2. Connect the negative sensor inputs to GND pins on the NI 9752. The polarity of the sensor connection to the NI 9752 is critical. Connect the leads of the sensor so that the positive input of the VR circuit receives the waveform shown in Figure 8. The waveform shown Figure 9 is incorrect, and the VR circuit does not properly respond to this waveform. The rapid zero crossing of the VR signal must be in the negative direction.

The physical center of each tooth or gap corresponds to a known angular position of the trigger wheel. This physical center of the tooth or gap always corresponds to the rapid zero-crossing of the generated voltage pulse.

The rapid negative zero-crossing of the raw sensor signal corresponds to the rising edge of a digital pulse sent to the RIO FPGA. The VR output signal to the FPGA becomes TRUE at the rapid negative zero crossing of the external VR pulse and remains TRUE until the external VR pulse returns to 0 V shown in Figure 10. Within LabVIEW FPGA, the system designer can route this digital signal to the EPT CrankSig input, EPT CamSig input, or any other speed measurement subVI.

**Figure 10.** VR Input Pulse and Resulting Digital Output from VR circuit

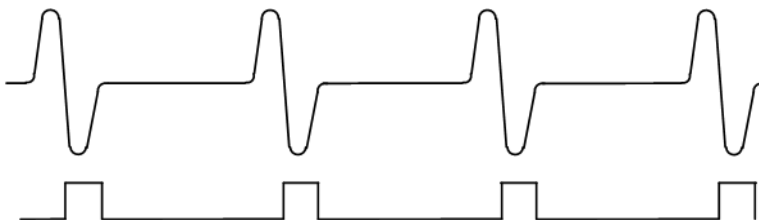

The absolute maximum VR pulse amplitude the circuit allows is 60 VDC. If the input signal exceeds this voltage, damage might occur to the circuit. The amplitude must not exceed 60 VDC at maximum engine speed. The minimum VR pulse amplitude that generates a digital output by the VR circuit is  $\pm 200$  mV.

The VR circuit implements adaptive noise rejection features during continuous incoming VR pulses. In general, an adaptive arming threshold voltage is generated with each VR pulse and bleeds down thereafter. The next pulse must have an amplitude that exceeds the arming threshold for a digital output to be generated at the rapid zero-crossing. The initial arming threshold is set to approximately 70% of the amplitude of each pulse.

Given a constant gap between the sensor and the trigger teeth, the amplitude of a VR pulse is directly proportional to the speed of the trigger wheel. For example, if the VR amplitude at 1000 RPM is  $\pm 10$  V, the amplitude at 2000 RPM is  $\pm 20$  V. By using an oscilloscope to measure the VR amplitude at a low speed, you can use this relationship to determine the maximum amplitude at the maximum speed. If the maximum amplitude of 60 VDC will be exceeded at maximum speed, you must increase the sensor gap or obtain a custom VR circuit configuration from NI.

## Hall-Effect Sensor Inputs

The NI 9752 includes two identical Hall-effect sensor input circuits. The Hall-effect inputs take a digital input from a Hall-effect or proximity sensor. Typical sensors include an open-collector output that requires a pull-up resistor at the collector. The Hall-effect inputs read active TTL compatible signals. The standard configuration includes a 4.7 k pull-up to 5 V for use with open-collector-type inputs. The input is protected against typical automotive battery voltages and can be connected to actively-driven battery voltage signals. Channels with this configuration are protected from voltage swings of  $\pm 30$  V.

The circuit output to the RIO FPGA reverses the polarity of the input by going low when the input voltage is greater than 2.0 V. The output goes high when the input is less than 1.0 V.

Figure 11 shows the standard configuration of the Hall-effect sensor input circuits.

**Figure 11. Hall-Effect Circuit Input Configuration**

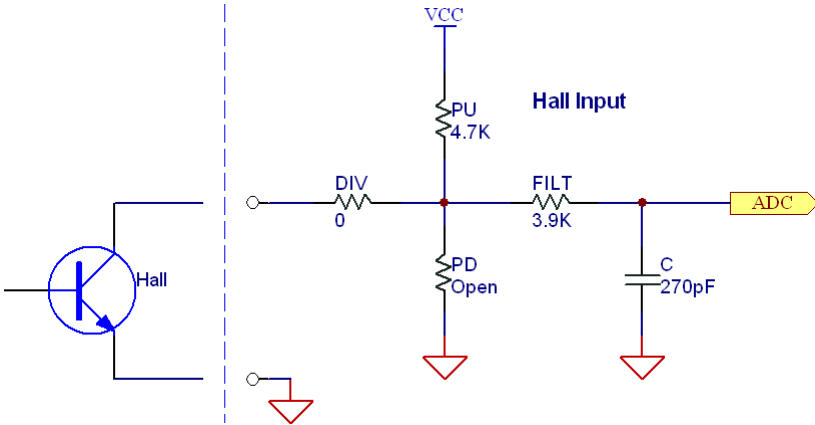

## Standard Circuit Configuration

The NI 9752 comes with a standard configuration as illustrated in Table 1 below.

**Table 1. Standard Analog Configuration**

| Channel | Pull-up Resistor | Pull-down Resistor | Divide Resistor | Break Frequency | Intended Use     |
|---------|------------------|--------------------|-----------------|-----------------|------------------|
| 1       | open             | 1 k $\Omega$       | 5.6 k           | 200 Hz          | 33 V Measurement |
| 2       | open             | 1 k $\Omega$       | 5.6 k           | 200 Hz          | 33 V Measurement |
| 3       | open             | 1 k $\Omega$       | 5.6 k $\Omega$  | 200 Hz          | 33 V Measurement |
| 4       | open             | 51 k $\Omega$      | 0 $\Omega$      | 500 Hz          | Active/Pot       |
| 5       | open             | 51 k $\Omega$      | 0 $\Omega$      | 500 Hz          | Active/Pot       |
| 6       | open             | 51 k $\Omega$      | 0 $\Omega$      | 500 Hz          | Active/Pot       |
| 7       | open             | 51 k $\Omega$      | 0 $\Omega$      | 500 Hz          | Active/Pot       |
| 8       | open             | 51 k $\Omega$      | 0 $\Omega$      | 500 Hz          | Active/Pot       |
| 9       | open             | 51 k $\Omega$      | 0 $\Omega$      | 500 Hz          | Active/Pot       |
| 10      | open             | 51 k $\Omega$      | 0 $\Omega$      | 500 Hz          | Active/Pot       |

**Table 1.** Standard Analog Configuration (Continued)

| Channel | Pull-up Resistor                 | Pull-down Resistor | Divide Resistor | Break Frequency | Intended Use      |
|---------|----------------------------------|--------------------|-----------------|-----------------|-------------------|
| 11      | open                             | 51 k $\Omega$      | 0 $\Omega$      | 500 Hz          | Active/Pot        |
| 12      | open                             | 51 k $\Omega$      | 0 $\Omega$      | 500 Hz          | Active/Pot        |
| 13      | open                             | 51 k $\Omega$      | 0 $\Omega$      | 500 Hz          | Active/Pot        |
| 14      | open                             | 51 k $\Omega$      | 0 $\Omega$      | 500 Hz          | Active/Pot        |
| 15      | open                             | 51 k $\Omega$      | 0 $\Omega$      | 500 Hz          | Active/Pot        |
| 16      | open                             | 51 k $\Omega$      | 0 $\Omega$      | 500 Hz          | Active/Pot        |
| 17      | 1 k $\Omega$                     | open               | 0 $\Omega$      | 500 Hz          | Thermistor/Switch |
| 18      | 1 k $\Omega$                     | open               | 0 $\Omega$      | 500 Hz          | Thermistor/Switch |
| 19      | 1 k $\Omega$                     | open               | 0 $\Omega$      | 500 Hz          | Thermistor/Switch |
| 20      | 1 k $\Omega$                     | open               | 0 $\Omega$      | 500 Hz          | Thermistor/Switch |
| 21      | 1 k $\Omega$                     | open               | 0 $\Omega$      | 500 Hz          | Thermistor/Switch |
| 22      | 2.5 V (0.2%) Precision Reference |                    |                 |                 |                   |

**Table 2.** Standard VR Configuration

| Channel | VR Amplitude Voltage |
|---------|----------------------|
| 1       | 60 VDC               |
| 2       | 60 VDC               |

**Table 3.** Standard Hall Configuration

| Channel | Pull-up Resistor | Pull-down Resistor | Divide Resistor | Break Frequency | Intended Use                   |
|---------|------------------|--------------------|-----------------|-----------------|--------------------------------|
| 1       | 4.7 k $\Omega$   | open               | 0 $\Omega$      | 150 kHz         | Hall, Proximity, Switch or TTL |
| 2       | 4.7 k $\Omega$   | open               | 0 $\Omega$      | 150 kHz         | Hall, Proximity, Switch or TTL |

# Custom Configuration

---

Visit [ni.com/info](http://ni.com/info) and enter Info Code ADCOMBO for more information about custom configuration.

## Physical Specifications and Characteristics

---

|                                  |                              |
|----------------------------------|------------------------------|
| Weight .....                     | 145 g                        |
| Maximum Altitude.....            | 2000 m                       |
| Operating Temperature .....      | -40 °C to 70 °C              |
| Maximum Ambient Temperature..... | 70 °C                        |
| Operating Humidity .....         | 10% to 90% RH, noncondensing |
| Pollution Degree .....           | 2                            |
| Ingress Protection .....         | IP40                         |

For indoor use only.

If you need to clean the module, wipe it with a dry towel.

## Safety Guidelines



**Caution** Do not operate this module in a manner not specified in these operating instructions. Do not exceed the 60VDC rating. Product misuse can result in a hazard. You can compromise the safety protection built into the product if the product is damaged in any way. If the product is damaged, return it to National Instruments for repair.

## Compliance and Certifications

---

### Safety

This product meets the requirements of the following standards of safety for electrical equipment for measurement, control, and laboratory use:

- IEC 61010-1, EN 61010-1
- UL 61010-1, CSA 61010-1

### Electromagnetic Compatibility

This product meets the requirements of the following EMC standards for electrical equipment for measurement, control, and laboratory use:

- EN 61326-1 (IEC 61326-1): Class A emissions; Industrial immunity
- EN 55011 (CISPR 11): Group 1, Class A emissions
- AS/NZS CISPR 11: Group 1, Class A emissions

- FCC 47 CFR Part 15B: Class A emissions
- ICES-001: Class A emissions



**Caution** When operating this product, use shielded cables and accessories.

## CE Compliance

This product meets the essential requirements of applicable European Directives as follows:

- 2006/95/EC; Low-Voltage Directive (safety)
- 2004/108/EC; Electromagnetic Compatibility Directive (EMC)

## Environmental Management

NI is committed to designing and manufacturing products in an environmentally responsible manner. NI recognizes that eliminating certain hazardous substances from our products is beneficial to the environment and to NI customers.

For additional environmental information, refer to the *Minimize Our Environmental Impact* web page at [ni.com/environment](http://ni.com/environment). This page contains the environmental regulations and directives with which NI complies, as well as other environmental information not included in this document.

## Waste Electrical and Electronic Equipment (WEEE)



**EU Customers** At the end of the product life cycle, all products *must* be sent to a WEEE recycling center. For more information about WEEE recycling centers, National Instruments WEEE initiatives, and compliance with WEEE Directive 2002/96/EC on Waste and Electronic Equipment, visit [ni.com/environment/weee](http://ni.com/environment/weee).

## Battery Replacement and Disposal



**Battery Directive** This device contains a long-life coin cell battery. If you need to replace it, use the Return Material Authorization (RMA) process or contact an authorized National Instruments service representative. For more information about compliance with the EU Battery Directive 2006/66/EC about Batteries and Accumulators and Waste Batteries and Accumulators, visit [ni.com/environment/batterydirective](http://ni.com/environment/batterydirective).

## 电子信息产品污染控制管理办法（中国 RoHS）



**中国客户** National Instruments 符合中国电子信息产品中限制使用某些有害物质指令 (RoHS)。关于 National Instruments 中国 RoHS 合规性信息, 请登录 [ni.com/environment/rohs\\_china](http://ni.com/environment/rohs_china)。(For information about China RoHS compliance, go to [ni.com/environment/rohs\\_china](http://ni.com/environment/rohs_china).)

Refer to the *NI Trademarks and Logo Guidelines* at [ni.com/trademarks](http://ni.com/trademarks) for more information on National Instruments trademarks. Other product and company names mentioned herein are trademarks or trade names of their respective companies. For patents covering National Instruments products/technology, refer to the appropriate location: **Help»Patents** in your software, the `patents.txt` file on your media, or the *National Instruments Patents Notice* at [ni.com/patents](http://ni.com/patents). You can find information about end-user license agreements (EULAs) and third-party legal notices in the readme file for your NI product. Refer to the *Export Compliance Information* at [ni.com/legal/export-compliance](http://ni.com/legal/export-compliance) for the National Instruments global trade compliance policy and how to obtain relevant HTS codes, ECCNs, and other import/export data.

© 2013 National Instruments. All rights reserved.