

COMPREHENSIVE SERVICES

We offer competitive repair and calibration services, as well as easily accessible documentation and free downloadable resources.

SELL YOUR SURPLUS

We buy new, used, decommissioned, and surplus parts from every NI series. We work out the best solution to suit your individual needs.

 Sell For Cash  Get Credit  Receive a Trade-In Deal

OBSOLETE NI HARDWARE IN STOCK & READY TO SHIP

We stock **New, New Surplus, Refurbished, and Reconditioned** NI Hardware.



Bridging the gap between the manufacturer and your legacy test system.

 1-800-915-6216

 www.apexwaves.com

 sales@apexwaves.com

All trademarks, brands, and brand names are the property of their respective owners.

Request a Quote

 **CLICK HERE**

SMD-7620

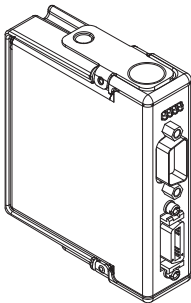
OPERATING INSTRUCTIONS AND SPECIFICATIONS

NI 9512

Stepper Drive Interface Module with Feedback

Français Deutsch 日本語 한국어 简体中文

ni.com/manuals



This document describes how to use the National Instruments 9512 module and includes specifications and pin assignments for the NI 9512.



Note The safety guidelines and specifications in this document are specific to the NI 9512. The other components in the system may not meet the same safety ratings and specifications. Refer to the documentation for each component in the system to determine the safety ratings and specifications for the entire system.

Related Information



NI CompactRIO Documentation

ni.com/info ⇌ [cseriesdoc](#)



Chassis Compatibility

ni.com/info ⇌ [compatibility](#)



Software Support

ni.com/info ⇌ [rdsoftwareversion](#)



Services

ni.com/services

Safety Guidelines

Operate the NI 9512 only as described in these operating instructions.

Safety Guidelines for Hazardous Locations

The NI 9505 is suitable for use in Class I, Division 2, Groups A, B, C, D, T4 hazardous locations; Class I, Zone 2, AEx nA IIC T4 and Ex nA IIC T4 hazardous locations; and nonhazardous locations only. Follow these guidelines if you are installing the NI 9505 in a potentially explosive environment. Not following these guidelines may result in serious injury or death.



Caution Do not disconnect I/O-side wires or connectors unless power has been switched off or the area is known to be nonhazardous.



Caution Do not remove modules unless power has been switched off or the area is known to be nonhazardous.



Caution Substitution of components may impair suitability for Class I, Division 2.



Caution For Division 2 and Zone 2 applications, install the system in an enclosure rated to at least IP 54 as defined by IEC/EN 60079-15.



Caution For Division 2 and Zone 2 applications, install a protection device between the input signal and the Vsup pin. The device must prevent the Vsup-to-channel voltage from exceeding 42 V if there is a transient overvoltage condition.

Special Conditions for Hazardous Locations Use in Europe and Internationally

This equipment has been evaluated as Ex nA IIC T4 Gc equipment under DEMKO Certificate No. 07 ATEX 0626664X and is IECEx UL 14.0089X certified. Each module is marked Ex II 3G and is suitable for use in Zone 2 hazardous locations, in ambient temperatures of $-40\text{ }^{\circ}\text{C} \leq T_a \leq 70\text{ }^{\circ}\text{C}$. If you are using the NI 9512 in Gas Group IIC hazardous locations, you must use the device in an NI chassis that has been evaluated as Ex nC IIC T4, Ex IIC T4, Ex nA IIC T4, or Ex nL IIC T4 equipment.



Caution You must make sure that transient disturbances do not exceed 140% of the rated voltage.



Caution The system shall only be used in an area of not more than Pollution Degree 2, as defined in IEC 60664-1.



Caution The system shall be mounted in an ATEX/IECEX-certified enclosure with a minimum ingress protection rating of at least IP54 as defined in IEC/EN 60079-15.



Caution The enclosure must have a door or cover accessible only by the use of a tool.

Electromagnetic Compatibility Guidelines

This product was tested and complies with the regulatory requirements and limits for electromagnetic compatibility (EMC) as stated in the product specifications. These requirements and limits are designed to provide reasonable protection against harmful interference when the product is operated in its intended operational electromagnetic environment.

This product is intended for use in industrial locations. As such, there is no guarantee that harmful interference will not occur in a particular installation, when the product is connected to a test object, or if the product is used in residential areas. To minimize the potential for the product to cause interference to radio and television reception or to experience unacceptable performance

degradation, install and use this product in strict accordance with the instructions in the product documentation.

Furthermore, any changes or modifications to the product not expressly approved by National Instruments could void your authority to operate it under your local regulatory rules.



Caution To ensure compliance with the applicable regulatory requirements, product installation requires either special considerations or user-installed, add-on devices. See the product installation instructions for further information.



Caution The inputs/outputs of this product can be damaged if subjected to Electrostatic Discharge (ESD). To prevent damage, industry-standard ESD prevention measures must be employed during installation, maintenance, and operation.

Special Conditions for Marine Applications

Some modules are Lloyd's Register (LR) Type Approved for marine applications. To verify Lloyd's Register certification, go to ni.com/certification and search for the LR certificate, or look for the Lloyd's Register mark on the module.



Caution To meet radio frequency emission requirements for marine applications, use shielded cables and install the system in a metal enclosure. Suppression ferrites must be installed on power supply inputs near power entries to modules and controllers. Power supply and module cables must be separated on opposite sides of the enclosure and must enter and exit through opposing enclosure walls.

Connecting the NI 9512

The NI 9512 stepper drive interface module is part of a family of C Series motion modules. The module provides stepper drive interface signals for a single axis, a full set of motion I/O including inputs for a home switch and limit switches, incremental encoder inputs for position feedback, and 0 to 30 V digital input and output lines. The NI 9512 also includes a processor to run the spline interpolation engine and patented NI step generation algorithm. Working together they produce smoother motion resulting in precise stepper motion control.

System Connection

The NI 9512 has two connectors, a 15-pin DSUB drive interface connector and a 20-pin MDR feedback connector. The 15-pin

DSUB includes command signals for interfacing with stepper drives, 0 to 30 V general-purpose digital input and output lines, and a +19 to 30 V input for power connection. Refer to Table 2 for the DSUB connector pin assignments.

The 20-pin MDR connector includes incremental encoder feedback inputs, a +5 V output for encoder power, home, limit, and position compare inputs, an output for position compare, an additional +19 to 30 V input for power connection, and an additional 0 to 30 V general-purpose digital input line. Refer to Figure 2 for the MDR connector pin assignments.



Note The NI 9512 requires an external power supply. You can connect the external power supply to the V_{sup} input provided on the DSUB or MDR connector. Do not connect more than one external power supply to the module.

NI 9512 Connection Options

National Instruments offers several options for connecting the NI 9512 to stepper or position command servo drives. Refer to Table 1 for available NI 9512 connection options.

Table 1. NI 9512 Connection Options

Drive	Connection Option
NI ISM-7400/7401/ 7402 NI SMD-7610 NI SMD-7611/7612 NI SMD-7620/7621	Direct Connectivity to NI ISM and NI SMD stepper drives Go to ni.com/info and enter <code>stepper</code> for installation and configuration information for NI ISM and NI SMD stepper drives.
AKD Analog Servo	NI 9512 to AKD Drive Cable (NI part number 781525-01) Refer to <i>Getting Started with NI 9512 C Series Drive Interface Modules and AKD Analog Servo Drives</i> for installation and configuration information for AKD servo drives
Mitsubishi MR-J2 or MR-J3	NI 9930M Motion Control Accessory (NI part number 781824-01) Refer to <i>NI 9930 Motion Control Accessories User Guide</i> for installation and configuration information for connection to Mitsubishi, p-command servo drives.

Table 1. NI 9512 Connection Options (Continued)

Drive	Connection Option
Panasonic Minas-A or Minas-A5	NI 9930P Motion Control Accessory (NI part number 781823-01) Refer to <i>NI 9930 Motion Control Accessories User Guide</i> for installation and configuration information for connection to Panasonic p-command servo drives.
Yaskawa Sigma-II or Sigma-V	NI 9930Y Motion Control Accessory (NI part number 781822-01) Refer to <i>NI 9930 Motion Control Accessories User Guide</i> for installation and configuration information for connection to Yaskawa p-command servo drives.
Other third-party stepper drive	NI 951x cable and terminal block bundle (NI part number 780553-01) Refer to the <i>Getting Started with NI 951x C Series Drive Interface Modules and LabVIEW</i> for information about using the NI 9512 with other devices.

How to Connect the NI 9512 to Drives and I/O

Complete the following steps to connect the NI 9512 stepper drive interface module to drives and other I/O:

1. Install the module in the chassis as specified in the chassis documentation.



Note Refer to the *SoftMotion Module* book of the *LabVIEW Help* for information about chassis, slot, or software restrictions.

2. Connect the module to a drive and other I/O using one of the connection options in Table 1.
3. Connect the NI 9512 module to an external power supply.



Caution Do *not* connect anything to pins marked Reserved.



Caution The 37-pin terminal block has separate V_{sup} and COM terminals for each connector. Make sure you are using the correct V_{sup} and COM terminals for the connector you are using. All signals associated with the DSUB connector in Figure 3 are marked with a dagger (†).

Figure 1 shows a simplified system connection diagram.

Figure 1. NI 9512 Connection Example

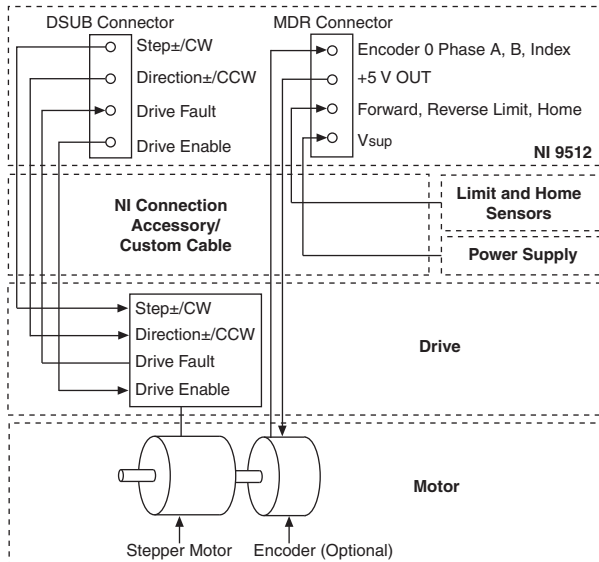


Table 2. NI 9512 DSUB Connector Pin Assignments

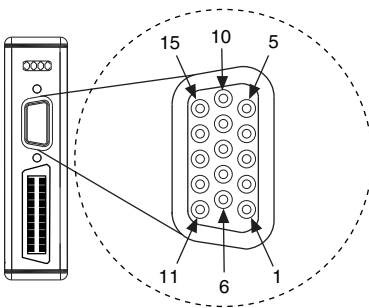
Connector	Pin	Signal
	1	Reserved
	2	Drive Enable
	3	Digital Input 3
	4	Digital Input 2
	5	Digital Output 1
	6	Reserved
	7	COM
	8	Digital Input 1
	9	Direction (CCW)-
	10	Step (CW)-
	11	Digital Output 0
	12	Vsup
	13	Direction (CCW)+
	14	COM
	15	Step (CW)+

Figure 2. NI 9512 MDR Connector Pin Assignments

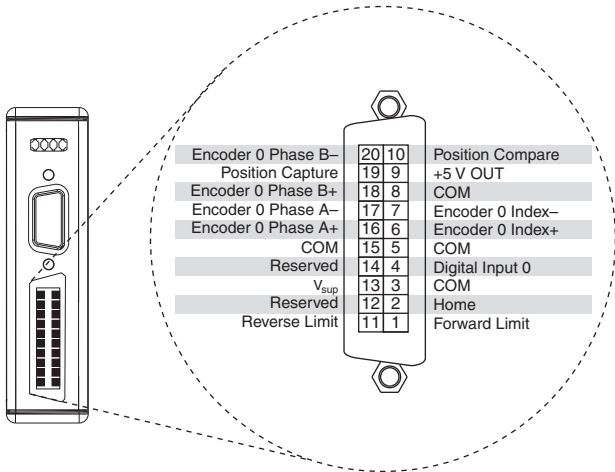








































Figure 3. NI 9512 37-Pin Terminal Block Pin Assignments

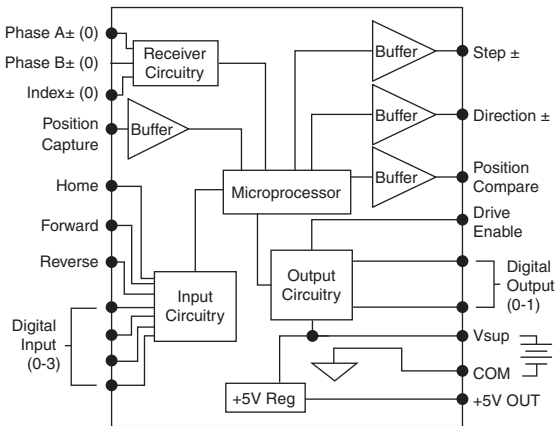
Forward Limit			Digital Output 1 [†]
Home			Reverse Limit
COM			Reserved
Digital Input 0			V _{sup}
COM			Reserved
Encoder 0 Index+			COM
Encoder 0 Index-			Encoder 0 Phase A+
COM			Encoder 0 Phase A-
+5V OUT			Encoder 0 Phase B+
Position Compare			Position Capture
Reserved			Encoder 0 Phase B-
Reserved			Reserved
Digital Output 0 [†]			Reserved
V _{sup} [†]			COM [†]
Digital Input 1 [†]			Drive Enable [†]
Direction (CCW)+ [†]			Digital Input 3 [†]
COM [†]			Direction (CCW)- [†]
Step (CW)+ [†]			Digital Input 2 [†]
Shield			Step (CW)- [†]

[†] Indicates DSUB connector signals.

Signal Connections

Figure 4 shows the NI 9512 block diagram.

Figure 4. NI 9512 Block Diagram



Note This document provides a brief overview of the module signal connections. Refer to the *NI 951x User*

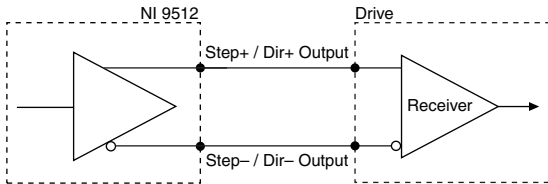
Manual, which you can download from ni.com/manuals, for more information about signal connections.

Step and Direction Outputs

The NI 9512 module supports both industry standards for stepper command signals—step and direction, or clockwise (CW) and counterclockwise (CCW) pulse outputs. The step and direction output circuits are software configurable for either single-ended or differential output type.

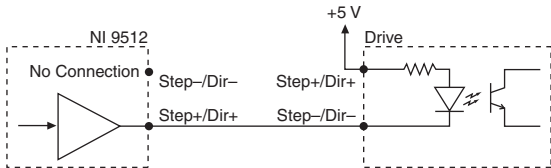
When connecting to drives with differential receiver inputs, configure the output type in software to differential and connect as shown in Figure 5.

Figure 5. Differential Step and Direction Output Connection



Many stepper drive manufacturers offer opto-isolated inputs for Step (CW)/Direction (CCW) signals. When connecting to opto-isolated inputs, configure the Step output type to single-ended, connect the NI 9512 Step+ output to the negative (cathode) side of the optocoupler input, and leave the Step- output on the NI 9512 disconnected. Connect the positive (anode) side of the drive input to a supply as specified by the drive manufacturer. Figure 6 shows a single-ended connection example.

Figure 6. Opto-Isolated Step and Direction Output Connection



Encoder Signals

The encoder channel consists of a Phase A, a Phase B, and an Index input. The NI 9512 supports RS-422 differential and single-ended inputs for Phase A, Phase B, and Index signals, and provides a +5 V output for encoder power. National Instruments strongly recommends you use encoders with differential line driver outputs

for optimized noise immunity and improved accuracy in all applications. Figures 7 and 8 show simplified schematic diagrams of the encoder input circuit connected to differential and single-ended encoder outputs.

Figure 7. Differential Encoder Input Circuit

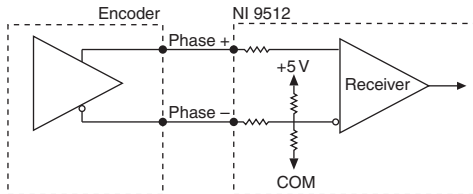
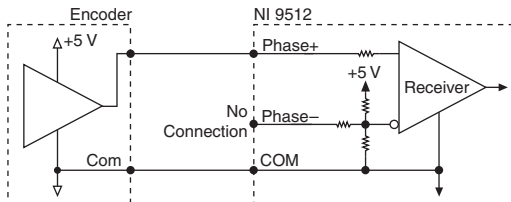


Figure 8. Single-Ended Encoder Input Circuit



Limit and Digital Input Signals

You can configure the Forward Limit, Reverse Limit, Home, and Digital Input <1..4> circuits in software for current sinking or sourcing output devices and set the active state of the inputs in software to on or off. To use the Drive Fault functionality referenced in Figure 1, you can map an available digital input in software. Figure 9 shows an example of wiring the inputs to a sourcing output device.

Figure 9. Limit or Digital Input Circuit Configured for Sinking

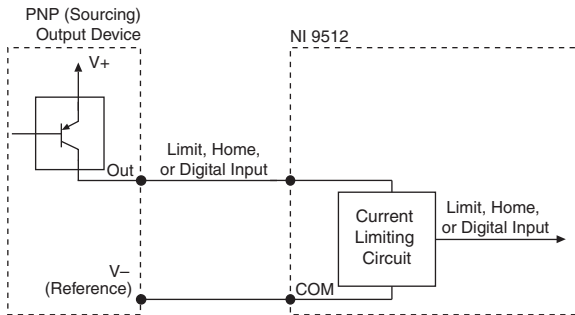
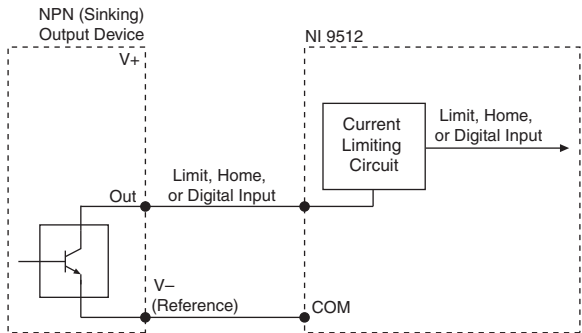


Figure 10 shows an example of wiring the inputs to a sinking output device.

Figure 10. Limit or Digital Input Circuit Configured for Sourcing



Drive Enable

The NI 9512 Drive Enable and Digital Output <1..2> circuits are software configurable for sinking or sourcing output type and the active state is software configurable for on or off.



Caution Do *not* connect digital outputs to +5 V input circuitry.



Caution Do *not* connect the Drive Enable output to a +5 V input circuit when the Drive Enable output is configured for sourcing.

Figure 11 shows an example of wiring the outputs to a sinking input device.

Figure 11. Drive Enable or Digital Output Circuit Configured for Sinking

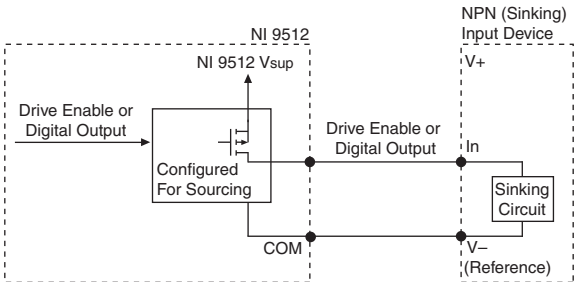
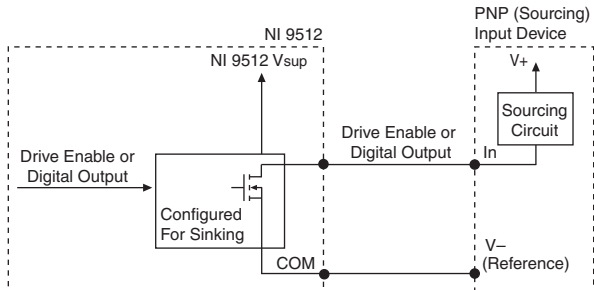


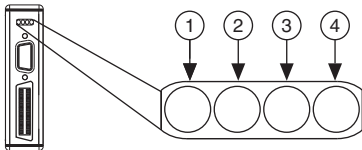
Figure 12 shows an example of wiring the outputs to a sourcing input device.

Figure 12. Drive Enable or Digital Output Circuit Configured for Sinking



LED Indicators

The NI 9512 has four LEDs to display status information.



-
- | | |
|---|------------------------|
| 1 | Axis Status (Green) |
| 2 | Encoder Active (Green) |

- | | |
|---|-----------------------|
| 3 | Limit Active (Yellow) |
| 4 | Axis Fault (Red) |
-

Axis Status

The Axis Status LED (green) has three states to display axis status.

- **Off**—The module is in sleep mode or failed to boot correctly. Refer to the *SoftMotion Module* book of the *LabVIEW Help* for troubleshooting information.
- **Flashing**—The module booted up correctly and is functional.
- **Lit**—The module is functional and the drive enable output is active.

Encoder Active

The Encoder Active LED (green) has three states for encoder and V_{sup} status.

- **Off**—The required power supply (V_{sup}) is not connected. You must connect a power supply to receive encoder pulses.
- **Flashing**—The power supply (V_{sup}) is connected and the module is receiving encoder pulses.



Note The LED flash rate does not correspond to the rate at which the NI 9512 receives encoder pulses.

- **Lit**—The power supply (V_{sup}) is connected but the module is not receiving encoder pulses.

Limit Active

The Limit Active LED (yellow) has two states to display the status of the limits and home input.

- **Off**—The power supply (V_{sup}) is not connected, or both the limits and home input are not active.
- **Lit**—The power supply (V_{sup}) is connected and the forward limit, reverse limit, or home input is active.

Axis Fault

The Axis Fault LED (red) has two states to indicate the presence of a fault in the system. Refer to the *SoftMotion Module* book of the *LabVIEW Help* for a list of module faults and troubleshooting information.

- **Off**—No module faults.
- **Lit**—One or more module faults.

Sleep Mode

This module supports a low-power sleep mode. Support for sleep mode at the system level depends on the chassis that the module is plugged into. Refer to the chassis manual for information about support for sleep mode. If the chassis supports sleep mode, refer to the software help for information about enabling sleep mode. Visit ni.com/info and enter `cseriesdoc` for information about C Series documentation.

Typically, when a system is in sleep mode, you cannot communicate with the modules. In sleep mode, the system consumes minimal power and may dissipate less heat than it does in normal mode. Refer to the *Specifications* section for more information about power consumption and thermal dissipation.

Specifications

The following specifications are typical for the range -40 to 70 °C unless otherwise noted. All voltages are relative to COM unless otherwise noted.

Stepper Performance

Stepper accuracy	1 full, half, or microstep
Interpolation/spline rate	20 kHz max

Motion Command Signals

Stepper outputs

Output type	Software-selectable: single-ended or differential
-------------------	--

Digital logic levels, single-ended

High, VOH	5.25 V max
-----------------	------------

Sourcing 20 mA	3.5 V min
----------------------	-----------

Sourcing 12 mA	3.7 V min
----------------------	-----------

Sourcing 4 mA	3.9 V min
---------------------	-----------

Low, VOL

Sinking 20 mA	0.9 V max
---------------------	-----------

Sinking 12 mA 0.7 V max

Sinking 4 mA 0.5 V max

Digital logic levels, differential (Step/Dir(+)-Step/Dir(-))

At 20 mA ± 1 V min

At 12 mA ± 1.5 V min

At 4 mA ± 2 V min

Max pulse rate 5 MHz

Continuous output current

on each channel ± 20 mA

Pulse width Approximately 50% of the period, up to 6.4 μ s max

Output mode Software-selectable: step and direction, or CW/CCW

Active state Software-selectable: high or low

Drive enable output

Output type Software-selectable: sinking or sourcing

Voltage range 0 to 30 V

Vsup input 19 to 30 V

Continuous output current (I_0)	
on each channel	± 100 mA max
Output impedance (R_0)	0.3Ω max
Output voltage (V_0) sourcing	$V_{sup} - (I_0 R_0)$
Output voltage (V_0) sinking	$I_0 R_0$
Min output pulse width	$100 \mu\text{s}$
Active state	Software-selectable: on or off

Motion I/O

Encoder 0 Phase A/B and Index inputs

Type	RS-422 differential or single-ended inputs
------------	--

Digital logic levels, single-ended

Voltage

High, V_{IH}

Low, V_{IL}

Digital logic levels, differential (Phase(+)) - Phase(-))

Input high range

Input low range

Common-mode voltage¹ -7 to 12 V

Input current at 5 V ± 1 mA

Min pulse width²

Differential 100 ns

Single-ended 400 ns

Max count rate

Differential 20×10^6 counts/sec

Single-ended 5×10^6 counts/sec

Forward, reverse, and home inputs

Input type Software-selectable: sinking
or sourcing

Limit or home input configured for sinking

Digital logic levels, OFF state

Input voltage ≤ 5 V

Input current $\leq 250 \mu\text{A}$

¹ Common-mode voltage is the average of Phase+ and Phase-.

² Assumes the minimum filter setting. Refer to the *SoftMotion Module* book of the *LabVIEW Help* for more information about filter options.

Digital logic levels, ON state

Input voltage 11 to 30 V

Input current..... ≥ 2 mA

Limit or home input configured for sourcing

Digital logic levels, OFF state

Input voltage 11 to 30 V

Input current..... ≤ 1 mA

Digital logic levels, ON state

Input voltage ≤ 5 V

Input current..... ≥ 2 mA

Min pulse width¹ 50 μ s

Position capture input

Digital logic levels

Voltage -0.25 to 5.25 V

High, VIH 2.0 V min

Low, VIL..... 0.8 V max

¹ Assumes the minimum filter setting. Refer to the *SoftMotion Module* book of the *LabVIEW Help* for more information about filter options.

Input current	
($0\text{ V} \leq V_{in} \leq 4.5\text{ V}$)	$\pm 2\text{ mA}$ max
Min pulse width ¹	100 ns
Max capture latency	200 ns
Capture accuracy	± 1 count
Active edge	Software-selectable: rising edge or falling edge

Position compare outputs

High, V_{OH}	5.25 V max
Sourcing 12 mA	3.7 V min
Sourcing 4 mA	3.9 V min
Low, V_{OL}	
Sinking 12 mA	0.7 V max
Sinking 4 mA	0.5 V max
Compare mode	Software-selectable: single or periodic
Compare action	Software-selectable: set, toggle, or pulse
Max compare rate (periodic)	5 MHz

Pulse width (programmable)

Min 100 ns

Max 1.6 ms

Active state Software-selectable: high or low

Digital I/O

Inputs

Number of inputs 4

Input type Software-selectable: sinking or sourcing

Digital input configured for sinking

Digital logic levels, OFF state

Input voltage ≤ 5 V

Input current ≤ 250 μ A

Digital logic levels, ON state

Input voltage 11 to 30 V

Input current ≥ 2 mA

Digital input configured for sourcing

Digital logic levels, OFF state

Input voltage 11 to 30 V

Input current..... ≤ 1 mA

Digital logic levels, ON state

Input voltage ≤ 5 V

Input current..... ≥ 2 mA

Min pulse width¹ 50 μ s

Outputs

Number of outputs..... 2

Output type Software-selectable: sinking
or sourcing

Voltage range..... 0 to 30 V

Vsup input 19 to 30 V

Continuous output current (I_O)

on each channel ± 100 mA max

Output impedance (R_O) 0.3 Ω max

¹ Assumes the minimum filter setting. Refer to the *SoftMotion Module* book of the *LabVIEW Help* for more information about filter options.

Output voltage (V_o) sourcing.....	$V_{sup} - (I_o R_o)$
Output voltage (V_o) sinking.....	$I_o R_o$
Min output pulse width	100 μ s
Leakage current	200 μ A
Active state	Programmable: on or off
MTBF	Contact NI for Bellcore MTBF or MIL-HDBK-217F specifications.

Power Requirements

Power consumption from chassis

Active mode	925 mW max
Sleep mode	0.4 mW max

Thermal dissipation (at 70 °C)

Active mode	1.5 W max
Sleep mode	0.4 mW max

NI 9512 Input and Output Characteristics

V_{sup} input	19 to 30 V, 375 mA max
+5 V regulated output.....	5 V \pm 5%, 150 mA max

Physical Characteristics

If you need to clean the module, wipe it with a dry towel.



Note For two-dimensional drawings and three-dimensional models of the C Series module and connectors, visit ni.com/dimensions and search by module number.

Weight..... 155 g (5.5 oz)

Safety

Safety Voltages

Connect only voltages that are within the following limits.

Channel-to-COM 0 to +30 VDC max,
Measurement Category I

Isolation

Channel-to-channel None

Channel-to-earth ground

Continuous 30 VDC,
Measurement Category I

Withstand 500 Vrms, verified by a 5 s
dielectric withstand test

Measurement Category I is for measurements performed on circuits not directly connected to the electrical distribution system referred to as *MAINS* voltage. MAINS is a hazardous live electrical supply system that powers equipment. This category is for measurements of voltages from specially protected secondary circuits. Such voltage measurements include signal levels, special equipment, limited-energy parts of equipment, circuits powered by regulated low-voltage sources, and electronics.



Caution Do not connect the NI 9512 to signals or use for measurements within Measurement Categories II, III, or IV.

Hazardous Locations

U.S. (UL)	Class I, Division 2, Groups A, B, C, D, T4; Class I, Zone 2, AEx nA IIC T4
Canada (C-UL)	Class I, Division 2, Groups A, B, C, D, T4; Class I, Zone 2, Ex nA IIC T4
Europe (DEMKO)	Ex nA IIC T4

Safety and Hazardous Location Standards

This product is designed to meet the requirements of the following standards of safety for electrical equipment for measurement, control, and laboratory use:

- IEC 61010-1, EN 61010-1
- UL 61010-1, CSA 61010-1
- EN 60079-0:2012, EN 60079-15:2010
- IEC 60079-0: Ed 6, IEC 60079-15; Ed 4
- UL 60079-0; Ed 5, UL 60079-15; Ed 3
- CSA 60079-0:2011, CSA 60079-15:2012



Note For UL and other safety certifications, refer to the product label or the [Online Product Certification](#) section.

Electromagnetic Compatibility

This product meets the requirements of the following EMC standards for electrical equipment for measurement, control, and laboratory use:

- EN 61326-1 (IEC 61326-1): Class A emissions; Industrial immunity

- EN 55011 (CISPR 11): Group 1, Class A emissions
- AS/NZS CISPR 11: Group 1, Class A emissions
- FCC 47 CFR Part 15B: Class A emissions
- ICES-001: Class A emissions



Note For the standards applied to assess the EMC of this product, refer to the *Online Product Certification* section.



Note For EMC compliance, operate this device with double-shielded cables.

CE Compliance

This product meets the essential requirements of applicable European directives as follows:

- 2014/35/EU; Low-Voltage Directive (safety)
- 2014/30/EU; Electromagnetic Compatibility Directive (EMC)
- 94/9/EC; Potentially Explosive Atmospheres (ATEX)

Online Product Certification

Refer to the product Declaration of Conformity (DoC) for additional regulatory compliance information. To obtain product certifications and the DoC for this product, visit ni.com/certification, search by module number or product line, and click the appropriate link in the Certification column.

Shock and Vibration

To meet these specifications, you must panel mount the system.

Operating vibration

Random (IEC 60068-2-64)..... 5 g_{rms}, 10 to 500 Hz

Sinusoidal (IEC 60068-2-6) 5 g, 10 to 500 Hz

Operating shock

(IEC 60068-2-27) 30 g, 11 ms half sine,
50 g, 3 ms half sine,
18 shocks at 6 orientations

Environmental

Refer to the manual for the chassis you are using for more information about meeting these specifications.

Operating temperature

(IEC 60068-2-1, IEC 60068-2-2) -40 to 70 °C

Storage temperature

(IEC 60068-2-1, IEC 60068-2-2) -40 to 85 °C

Ingress protection..... IP 40

Operating humidity

(IEC 60068-2-56)..... 10 to 90% RH,
noncondensing

Storage humidity

(IEC 60068-2-56)..... 5 to 95% RH,
noncondensing

Pollution Degree (IEC 60664)..... 2

Maximum altitude..... 5,000 m

Indoor use only.

Environmental Management

NI is committed to designing and manufacturing products in an environmentally responsible manner. NI recognizes that eliminating certain hazardous substances from our products is beneficial to the environment and to NI customers.

For additional environmental information, refer to the *Minimize Our Environmental Impact* web page at ni.com/environment. This page contains the environmental regulations and directives with which NI complies, as well as other environmental information not included in this document.

Waste Electrical and Electronic Equipment (WEEE)



EU Customers At the end of the product life cycle, all products *must* be sent to a WEEE recycling center. For more information about WEEE recycling centers, National Instruments WEEE initiatives, and compliance with WEEE Directive 2002/96/EC on Waste and Electronic Equipment, visit ni.com/environment/weee.

电子信息产品污染控制管理办法（中国 RoHS）



中国客户 National Instruments 符合中国电子信息产品中限制使用某些有害物质指令 (RoHS)。关于 National Instruments 中国 RoHS 合规性信息，请登录 ni.com/environment/rohs_china。(For information about China RoHS compliance, go to ni.com/environment/rohs_china.)

Worldwide Support and Services

The NI website is your complete resource for technical support. At ni.com/support you have access to everything from troubleshooting and application development self-help resources to email and phone assistance from NI Application Engineers.

Visit ni.com/services for NI Factory Installation Services, repairs, extended warranty, and other services.

Visit ni.com/register to register your NI product. Product registration facilitates technical support and ensures that you receive important information updates from NI.

A Declaration of Conformity (DoC) is our claim of compliance with the Council of the European Communities using the manufacturer's declaration of conformity. This system affords the

user protection for electromagnetic compatibility (EMC) and product safety. You can obtain the DoC for your product by visiting ni.com/certification. If your product supports calibration, you can obtain the calibration certificate for your product at ni.com/calibration.

NI corporate headquarters is located at 11500 North Mopac Expressway, Austin, Texas, 78759-3504. NI also has offices located around the world. For telephone support in the United States, create your service request at ni.com/support or dial 1 866 ASK MYNI (275 6964). For telephone support outside the United States, visit the Worldwide Offices section of ni.com/niglobal to access the branch office websites, which provide up-to-date contact information, support phone numbers, email addresses, and current events.

Refer to the *NI Trademarks and Logo Guidelines* at ni.com/trademarks for more information on National Instruments trademarks. Other product and company names mentioned herein are trademarks or trade names of their respective companies. For patents covering National Instruments products/technology, refer to the appropriate location: **Help»Patents** in your software, the `patents.txt` file on your media, or the *National Instruments Patent Notice* at ni.com/patents. You can find information about end-user license agreements (EULAs) and third-party legal notices in the `readme` file for your NI product. Refer to the *Export Compliance Information* at ni.com/legal/export-compliance for the National Instruments global trade compliance policy and how to obtain relevant HTS codes, ECCNs, and other import/export data. NI MAKES NO EXPRESS OR IMPLIED WARRANTIES AS TO THE ACCURACY OF THE INFORMATION CONTAINED HEREIN AND SHALL NOT BE LIABLE FOR ANY ERRORS. U.S. Government Customers: The data contained in this manual was developed at private expense and is subject to the applicable limited rights and restricted data rights as set forth in FAR 52.227-14, DFAR 252.227-7014, and DFAR 252.227-7015.

© 2009–2015 National Instruments. All rights reserved.