

## COMPREHENSIVE SERVICES

We offer competitive repair and calibration services, as well as easily accessible documentation and free downloadable resources.

## SELL YOUR SURPLUS

We buy new, used, decommissioned, and surplus parts from every NI series. We work out the best solution to suit your individual needs.

 Sell For Cash    Get Credit    Receive a Trade-In Deal

## OBSOLETE NI HARDWARE IN STOCK & READY TO SHIP

We stock **New, New Surplus, Refurbished, and Reconditioned** NI Hardware.



*Bridging the gap between the manufacturer and your legacy test system.*

 1-800-915-6216

 [www.apexwaves.com](http://www.apexwaves.com)

 [sales@apexwaves.com](mailto:sales@apexwaves.com)

*All trademarks, brands, and brand names are the property of their respective owners.*

**Request a Quote**

 **CLICK HERE**

**TB-2605**

# INSTALLATION GUIDE

# TB-2605 Isothermal Terminal Block

このドキュメントには、日本語ページも含まれています。

This installation guide describes how to install and connect signals to the TB-2605 isothermal terminal block for use with the NI 2501 and NI 2503 PXI switch cards.

## Contents

---

Introduction .....	1
What You Need to Get Started .....	2
Signal Names .....	2
Signal Connection .....	4
Installing Your Terminal Block .....	6
Installing the Analog Bus Plug .....	7
Cold-Junction Temperature Sensor.....	9
Specifications .....	11

## Introduction

---

The TB-2605 is an isothermal terminal block that consists of a printed circuit board with screw terminals. The terminal block connects directly to the front panel I/O connector of the NI 2501 or NI 2503.

The terminal block can easily accommodate thermocouples, resistance temperature detectors (RTDs), thermistors, and voltage signals. The TB-2605 features an isothermal construction to minimize the temperature gradients across the screw terminals and a high-accuracy thermistor cold-junction temperature sensor for measuring with thermocouples. Enclosures keep out air currents to maintain an isothermal environment for the screw terminals and the cold-junction sensor.

Use the screw terminals on the TB-2605 to make connections to all channels except the cold-junction sensor. The front side of the terminal block has two additional connectors for connecting to the analog bus. You can use the low-voltage AB plug to connect the analog bus of adjacent switch cards.

## What You Need to Get Started

---

You need the following to set up and use your terminal block:

- One of the following PXI switch cards:
  - NI 2501
  - NI 2503
- NI 2501/2503 User Manual*
- TB-2605 isothermal terminal block
- 0.10 in. slotted screwdriver
- No. 1 Phillips screwdriver
- Wire cutters
- Wire insulation stripper
- Analog bus connectors (to connect to multiple cards)

## Signal Names

---

The NI 2501/2503 has several modes of operation. The following figures show the names of the signal connections for the different modes of operation.



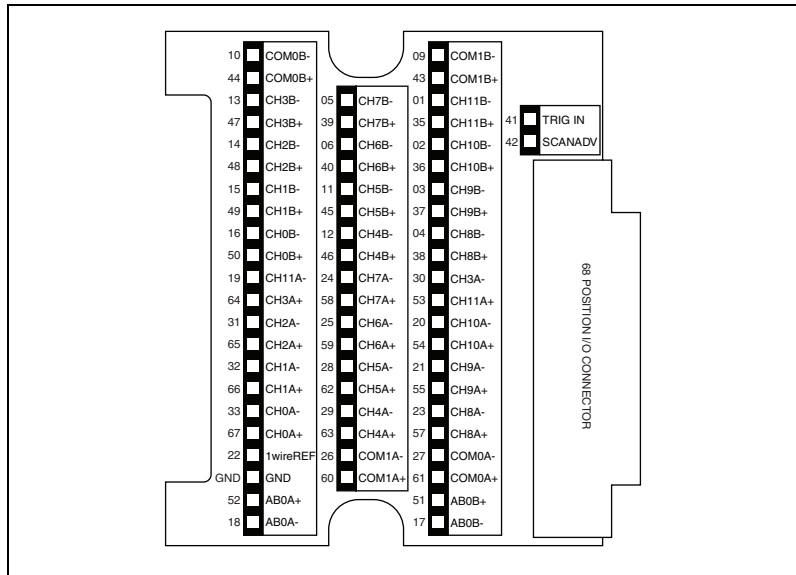
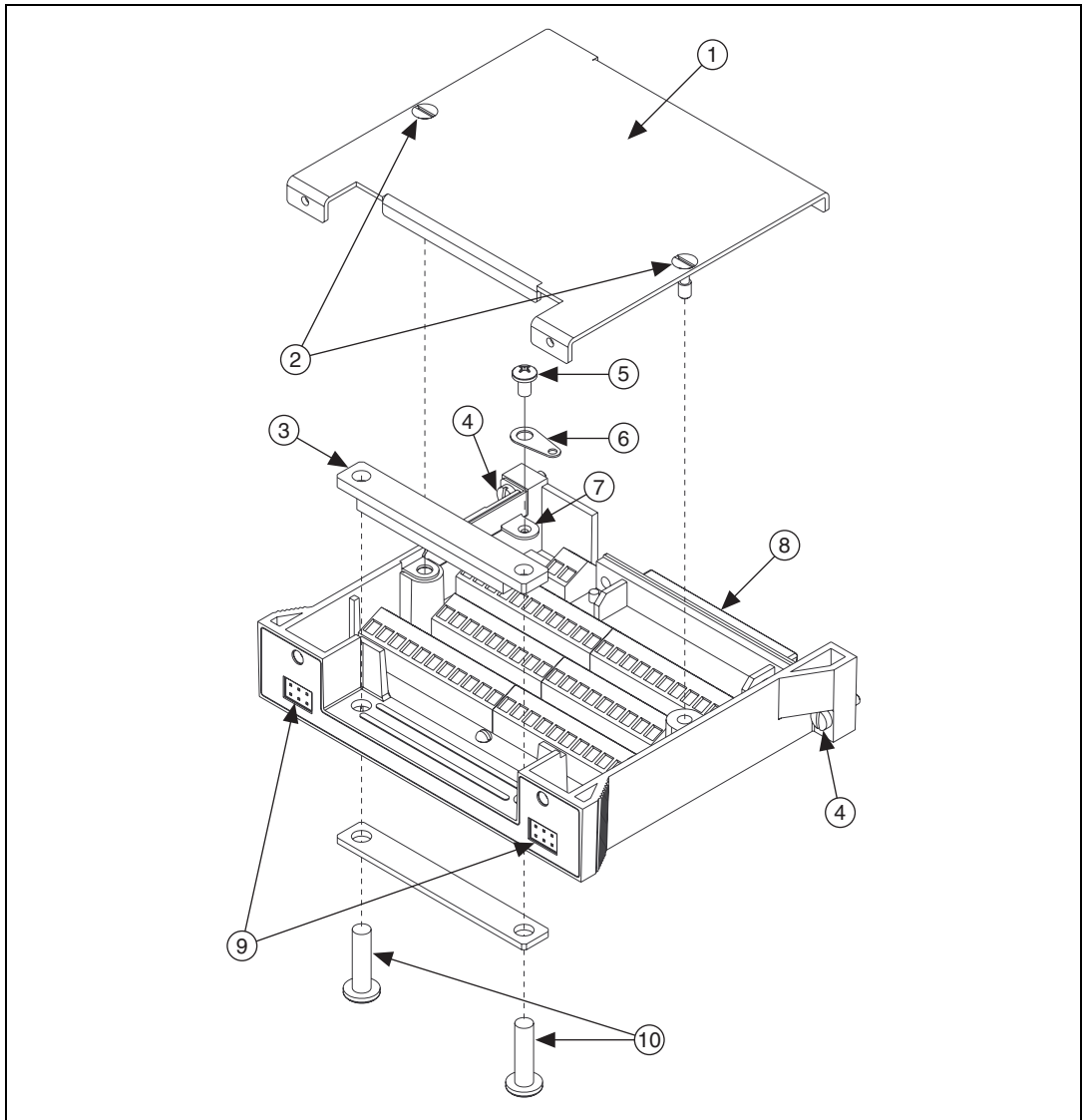

Figure 3. Four-Wire Mode

## Signal Connection

See your *NI 2501/2503 User Manual* for examples of how to connect your signals. Refer to Figure 4 as you perform the following steps to connect your signals to your terminal block (the numbers in parentheses refer to items in Figure 4).

1. Remove the terminal block cover (1) by unscrewing the two cover screws (2) using the 0.10 in. slotted screwdriver.
2. Loosen or remove the strain relief bar (3) by loosening the two strain relief screws (10).
3. Use wire cutters and wire insulation strippers to strip the wire ends as necessary to connect them to screw terminals.
4. Loosen the screws in the screw terminals with the 0.10 in. slotted screwdriver.
5. Insert the stripped wires into the screw terminals. Tighten the screws with the 0.10 in. slotted screwdriver.
6. Connect safety ground or shield wires to the chassis ground connection tab (7) using the provided solder lug (6).
7. Tighten or replace the strain relief screws (10).
8. Replace the terminal block cover (1) and tighten the cover screws (2).



1	Cover	5	Ground Lug Screw	8	Connection to Switch Card
2	Cover Screws (captive)	6	Ground Solder Lug	9	Analog Bus Connectors
3	Strain Relief Bar	7	Chassis Ground Tab	10	Strain Relief Screws
4	Chassis Connection Screws				

**Figure 4.** TB-2605 Parts Locator Diagram

# Installing Your Terminal Block

---



**Note** To minimize the temperature gradient inside the terminal block and thus maintain its isothermal nature for accurate cold-junction compensation, place the terminal block and chassis away from extreme temperature differentials.

Refer to Figure 5 as you perform the following steps to connect the terminal block to the NI 2501 or NI 2503 connector (the numbers in parentheses refer to items in Figure 5).



**Note** The TB-2605 terminal block must be installed on the NI 2501/2503 switch card after the card is installed in the chassis.

1. Install the switch card (3) into the chassis and tighten the two module screws (2).
2. Guide the terminal block onto the switch card connector (4).
3. Tighten the two terminal block mounting screws (1).



**Caution** The connectors of both the switch card and the terminal block are polarized. You can attach them in only one way. Do not force the terminal block when inserting it into or removing it from the NI 2501 or NI 2503 connector.

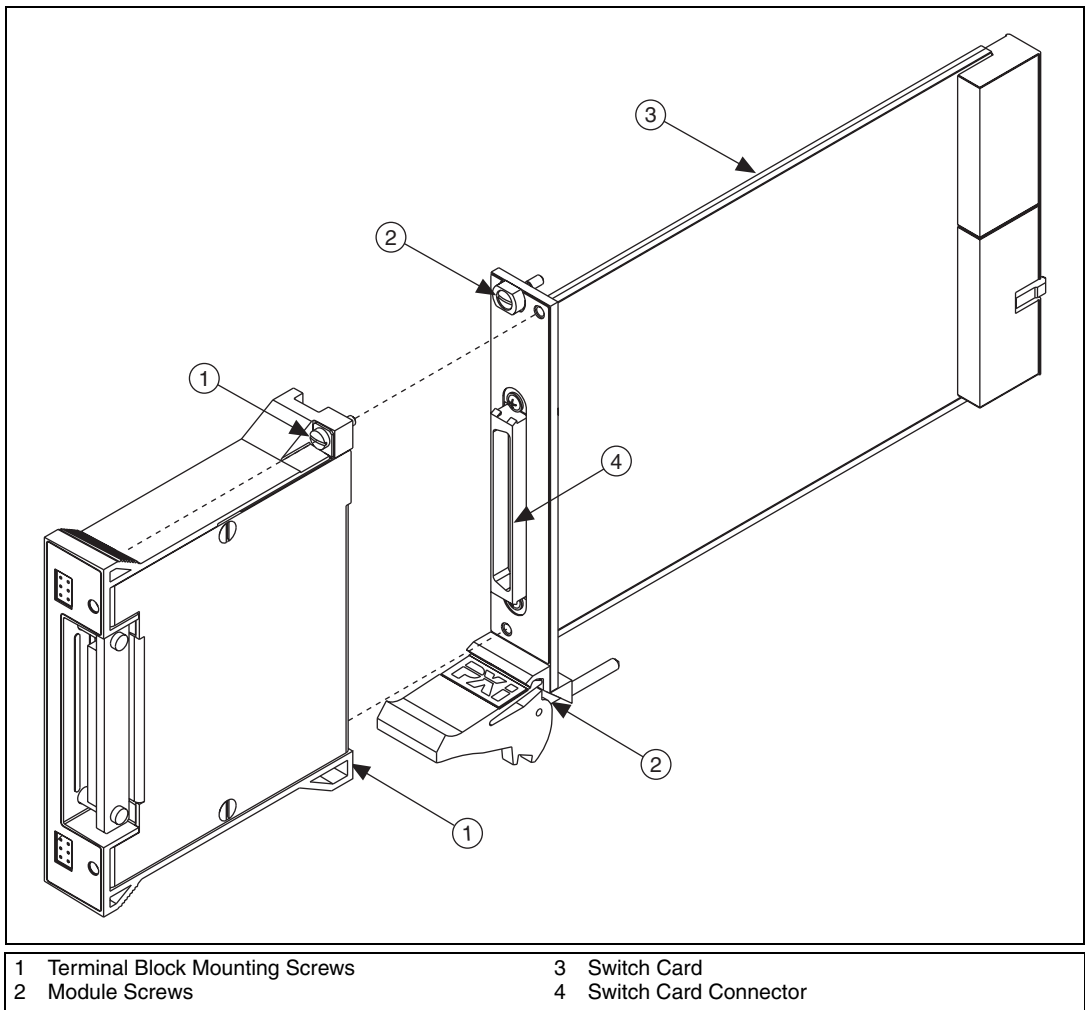

**Figure 5.** Connecting the TB-2605 to the Switch Card

## Installing the Analog Bus Plug

Refer to Figure 6 as you perform the following steps to install the analog bus plug. The cover should be attached to the terminal block before you connect the analog bus plug because the plug screws into the cover (the numbers in parentheses refer to items in Figure 6).

1. With two terminal blocks connected to boards in adjacent slots, connect the analog bus plug (3) into the analog bus connector (1) of each terminal block.
2. Tighten the screw (2) on the analog bus plug using the 0.10 in. slotted screwdriver.



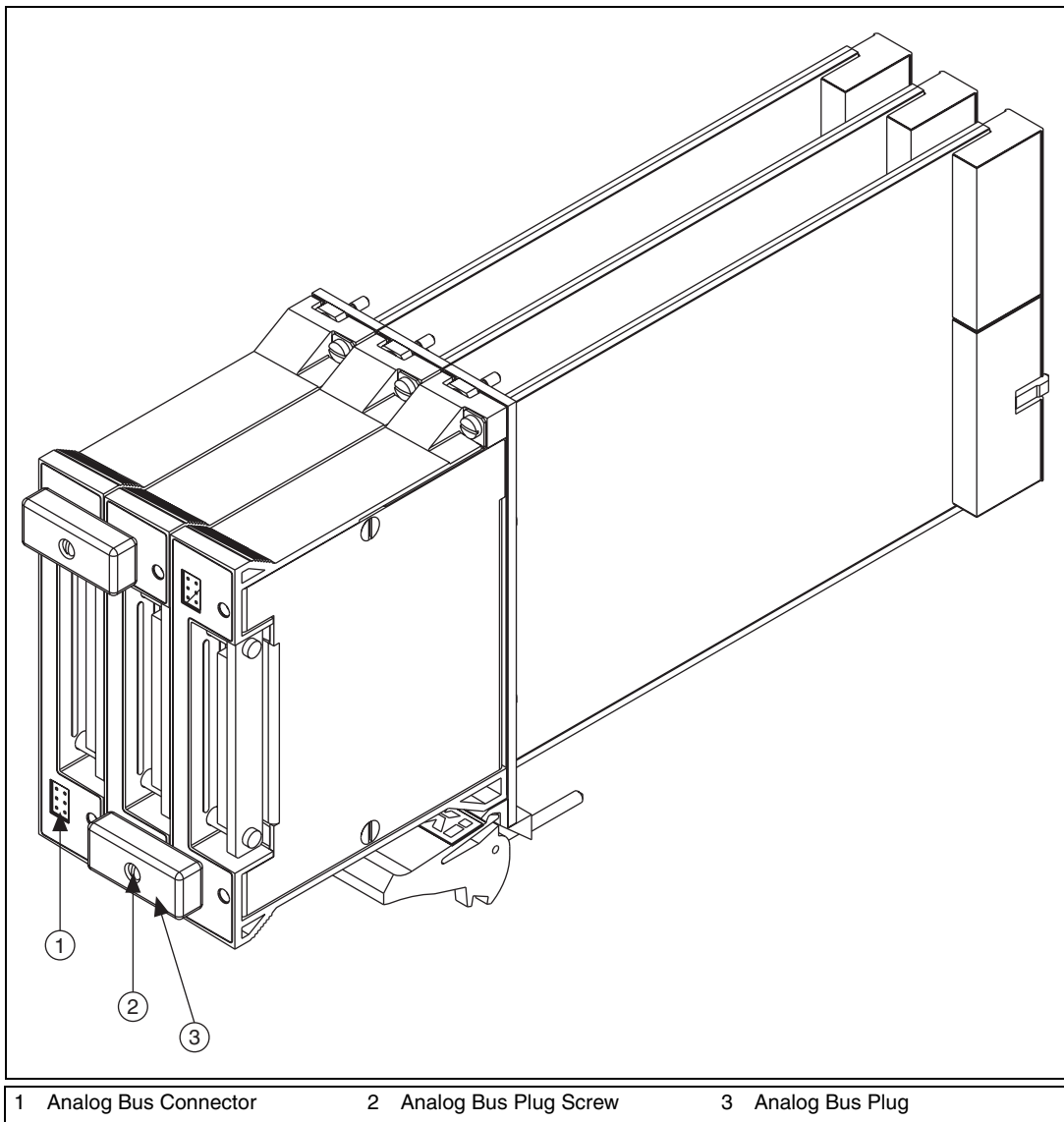

**Figure 6.** Installing the Analog Bus Plug

## Analog Bus Connector

The front side of the terminal block has two connectors for connecting to the analog bus. The low-voltage analog bus plug can be used to connect the analog buses of adjacent switch cards, as shown in Figure 6. The signal connections for the analog bus are shown in Figure 7.

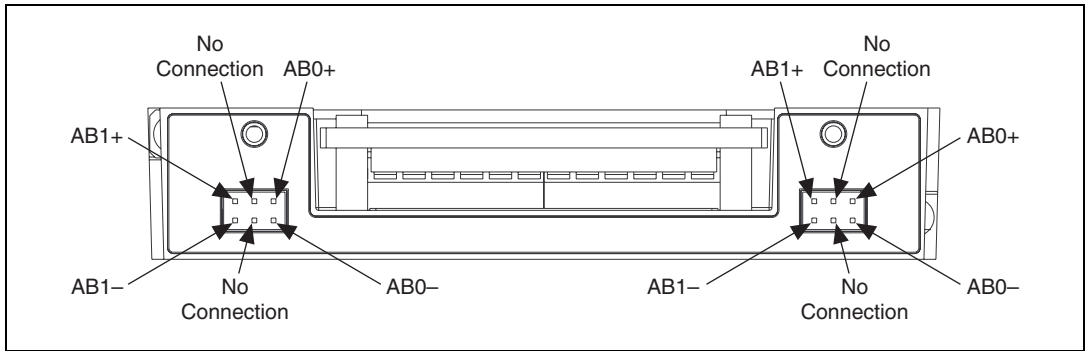

Figure 7. Analog Bus Connector

## Cold-Junction Temperature Sensor

The TB-2605 temperature sensor voltage output varies from 198.54 mV to 19.58 mV over the temperature range 0 to 55 °C, respectively, and has an accuracy of  $\pm 0.5$  °C over the 15 to 35 °C temperature range and  $\pm 0.9$  °C over the 0 to 15° and 35° to 55 °C temperature ranges.<sup>1</sup>

You can use the following formulas to convert the cold-junction sensor voltage to cold-junction temperature:

$$T(^{\circ}\text{C}) = T_K - 273.15$$

where  $T_K$  is the temperature in kelvin

$$r_K = \frac{1}{[a + b(\ln R_T) + c(\ln R_T)^3]}$$

$$a = 1.295361 \times 10^{-3}$$

$$b = 2.343159 \times 10^{-4}$$

$$c = 1.018703 \times 10^{-7}$$

$R_T$  = resistance of the thermistor

$$R_T = 189 K \left( \frac{V_{TEMPOUT}}{2.5 - V_{TEMPOUT}} \right)$$

$V_{TEMPOUT}$  = output voltage of the temperature sensor

$$T(^{\circ}\text{F}) = \frac{[T(^{\circ}\text{C})]9}{5} + 32$$

<sup>1</sup> Includes the combined effects of the temperature sensor accuracy and temperature difference between the temperature sensor and any screw terminal. The temperature sensor accuracy includes tolerances in all component values, the effects caused by temperature and loading, and self-heating.



# Specifications

---

## Cold-junction sensor

Accuracy <sup>1</sup> .....	0.5° from 15 to 35 °C 0.9° from 0° to 15° C and 35 to 55 °C
Repeatability .....	0.2° from 15 to 35 °C
Output .....	198.54 mV to 19.58 mV from 0 to 55 °C

Dimensions..... 8.4 by 10.7 by 2.0 cm  
(3.3 by 4.2 by 0.80 in.)

## Max voltage

(signal + common mode) ..... Each input should remain within  
30 V<sub>rms</sub> or 60 VDC of ground and  
all other channels to eliminate the  
possibility of hazardous shock.

---

<sup>1</sup> Includes the combined effects of the temperature sensor accuracy and the temperature difference between the temperature sensor and any screw terminal. The temperature sensor accuracy includes tolerances in all component values, the effects caused by temperature and loading, and self-heating.

National Instruments, NI, ni.com, and LabVIEW are trademarks of National Instruments Corporation. Refer to the *Terms of Use* section on [ni.com/legal](http://ni.com/legal) for more information about National Instruments trademarks. Other product and company names mentioned herein are trademarks or trade names of their respective companies. For patents covering National Instruments products, refer to the appropriate location: **Help»Patents** in your software, the `patents.txt` file on your CD, or [ni.com/patents](http://ni.com/patents).