

COMPREHENSIVE SERVICES

We offer competitive repair and calibration services, as well as easily accessible documentation and free downloadable resources.

SELL YOUR SURPLUS

We buy new, used, decommissioned, and surplus parts from every NI series. We work out the best solution to suit your individual needs.

 Sell For Cash  Get Credit  Receive a Trade-In Deal

OBSOLETE NI HARDWARE IN STOCK & READY TO SHIP

We stock **New**, **New Surplus**, **Refurbished**, and **Reconditioned** NI Hardware.



Bridging the gap between the manufacturer and your legacy test system.

 1-800-915-6216

 www.apexwaves.com

 sales@apexwaves.com

All trademarks, brands, and brand names are the property of their respective owners.

Request a Quote

 **CLICK HERE**

TB-2627

INSTALLATION INSTRUCTIONS

NI TB-2627

Terminal Block for the NI PXI/PXIe-2527

このドキュメントには、日本語ページも含まれています。

This guide describes how to install and connect signals to the National Instruments TB-2627 terminal block to configure your NI PXI/PXIe-2527 switch module as one of the following:

- 64 × 1 1-wire multiplexer
- 32 × 1 2-wire multiplexer
- 16 × 1 4-wire multiplexer
- Dual 32 × 1 1-wire multiplexer
- Dual 16 × 1 2-wire multiplexer

Refer to the *NI Switches Getting Started Guide* to determine when to install the NI TB-2627.

Introduction

The NI TB-2627 terminal block installs in front of the NI PXI/PXIe-2527 switch module. The NI TB-2627 has screw terminals that provide access to all channels of the multiplexer.



Caution The NI TB-2627 is rated for 300 V, Measurement Category I. Do *not* use this module with the NI PXI/PXIe-2527 for connections to signals or for measurements within Categories II, III, or IV. Do *not* connect to MAINS supply circuits (for example, wall outlets) of 115 or 230 VAC. Refer to the *Read Me First: Safety and Electromagnetic Compatibility* document for more information on measurement categories.

Conventions

The following conventions are used in this guide:

» The » symbol leads you through nested menu items and dialog box options to a final action. The sequence **File»Page Setup»Options** directs you to pull down the **File** menu, select the **Page Setup** item, and select **Options** from the last dialog box.



This icon denotes a note, which alerts you to important information.



This icon denotes a caution, which advises you of precautions to take to avoid injury, data loss, or a system crash.



When symbol is marked on a product, it denotes a warning advising you to take precautions to avoid electrical shock.

bold Bold text denotes items that you must select or click in the software, such as menu items and dialog box options. Bold text also denotes parameter names.

italic Italic text denotes variables, emphasis, a cross-reference, or an introduction to a key concept. Italic text also denotes text that is a placeholder for a word or value that you must supply.

monospace Text in this font denotes text or characters that you should enter from the keyboard, sections of code, programming examples, and syntax examples. This font is also used for the proper names of disk drives, paths, directories, programs, subprograms, subroutines, device names, functions, operations, variables, filenames, and extensions.

1. Unpack the Terminal Block

To avoid damage when you handle the terminal block, take the following precautions:



Caution *Never* touch the exposed pins of connectors.

- Ground yourself using a grounding strap or by touching a grounded object.
- Touch the antistatic package to a metal part of the chassis before you remove the terminal block from the package.

Remove the terminal block from the package and inspect the terminal block for loose components or any sign of damage. Notify NI if the terminal block appears damaged in any way.



Caution Do *not* install a damaged terminal block on a switch terminal block.

Store the terminal block in the antistatic package when not in use.

2. Verify the Components

Make sure you have the following:

- NI TB-2627 terminal block
- NI PXI/PXIe-2527 switch module
- PXI chassis
- 1/8 in. flathead screwdriver
- Wire cutter
- Wire insulation stripper

3. Connect Signals



Caution Ensure that power has not been applied to signals prior to connection. Only trained and qualified service personnel should install and connect signals.

To connect signals to the terminal block, complete the following steps:

1. Prepare the signal wire by stripping the insulation no more than 3/16 of an inch from the end of the wire.
2. Remove the terminal block top cover screws with the flathead screwdriver.
3. Gently lift the top cover off the terminal block.
4. Loosen the two screws on the strain-relief assembly and remove the top strain-relief bar.
5. Connect the safety earth ground to a safety ground lug.
6. Connect the wire to the terminal by inserting the stripped end of the wire into the terminal. When connecting a signal, refer to the terminal reference diagram in Figure 4.
7. Tighten the screw for the terminal to secure the connection.
8. Pull the wire through the strain-relief bar to remove the slack in the wiring.
9. Replace the strain-relief bar and tighten the two screws on the strain-relief assembly to secure the cables.

10. Replace the terminal block top cover.
11. Secure the terminal block top cover with the top cover screw.

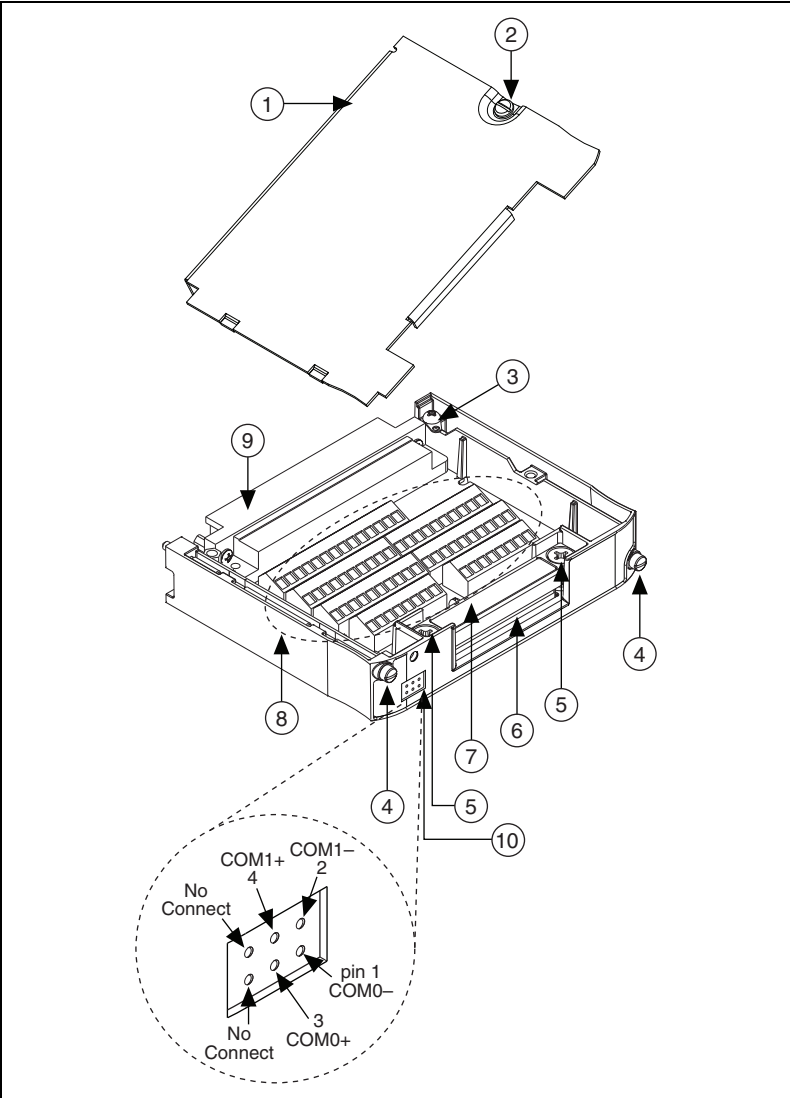

1 Terminal Block Top Cover	6 Strain-Relief Opening
2 Top Cover Screw	7 Strain-Relief Bar
3 Safety Ground Lug	8 Screw Terminals
4 Chassis Screws	9 Rear Connector
5 Strain-Relief Screws	10 Analog Bus*

* For connection to a DMM, use the HV6-BAN4 DMM cable described in the [Accessories](#) section.

Figure 1. NI TB-2627 Terminal Block



Caution In order to comply with standards and laws governing electromagnetic compatibility (EMC), you *must* install the NI 711627-01 snap-on ferrite shipped with the NI TB-2627 terminal block. Install the ferrite as close to the NI TB-2627 terminal block as possible. Wrap all wires exiting the terminal block around one side of the ferrite so that they pass through the ferrite twice, as shown in Figure 2 and Figure 3.

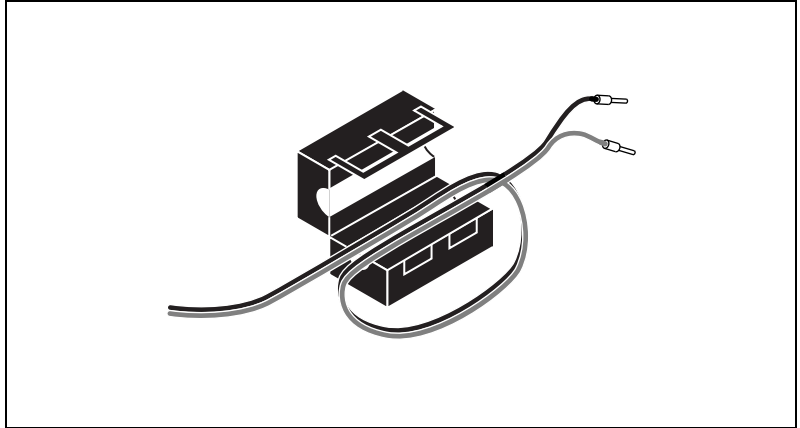

Figure 2. Open Ferrite Near Ends of Power Wires

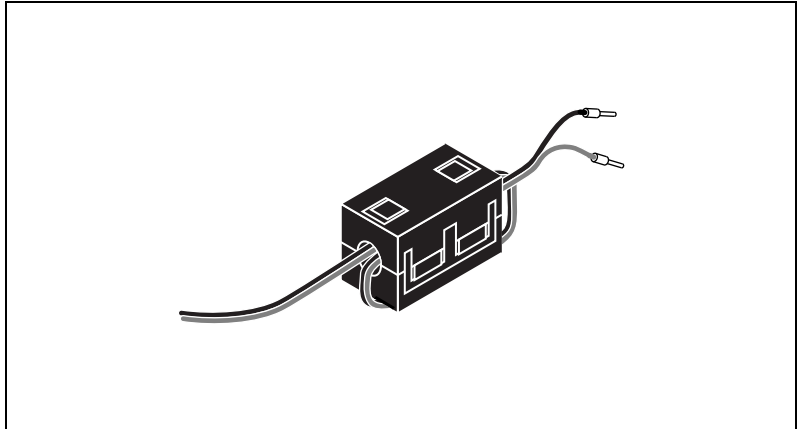
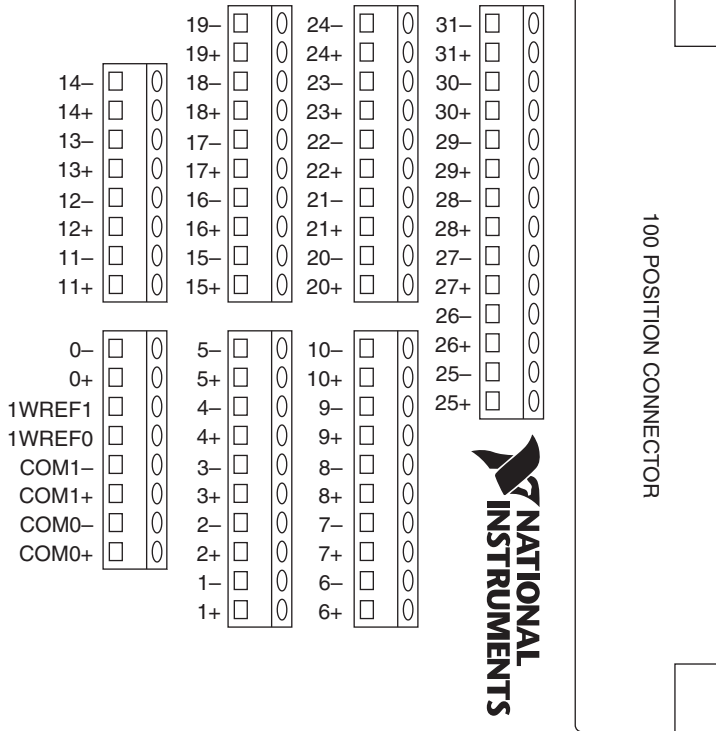

Figure 3. Closed Ferrite



WARNING: IF HIGH VOLTAGE IS PRESENT, CONNECT A SAFETY EARTH GROUND TO THE SAFETY GROUND LUG.

Figure 4. NI TB-2627 Terminal Reference Diagram

Table 1. 64 × 1 1-Wire Topology Terminal Mapping

Software Name	Terminal	Software Name	Terminal	Software Name	Terminal	Software Name	Terminal	Software Name	Terminal
ch0	0+	ch14	14+	ch28	28+	ch42	10-	ch56	24-
ch1	1+	ch15	15+	ch29	29+	ch43	11-	ch57	25-
ch2	2+	ch16	16+	ch30	30+	ch44	12-	ch58	26-
ch3	3+	ch17	17+	ch31	31+	ch45	13-	ch59	27-
ch4	4+	ch18	18+	ch32	0-	ch46	14-	ch60	28-
ch5	5+	ch19	19+	ch33	1-	ch47	15-	ch61	29-
ch6	6+	ch20	20+	ch34	2-	ch48	16-	ch62	30-
ch7	7+	ch21	21+	ch35	3-	ch49	17-	ch63	31-
ch8	8+	ch22	22+	ch36	4-	ch50	18-	1wref0	1WREF0
ch9	9+	ch23	23+	ch37	5-	ch51	19-	1wref1	1WREF1
ch10	10+	ch24	24+	ch38	6-	ch52	20-	com0+	COM0+
ch11	11+	ch25	25+	ch39	7-	ch53	21-	com0-	COM0-
ch12	12+	ch26	26+	ch40	8-	ch54	22-	com1+	COM1+
ch13	13+	ch27	27+	ch41	9-	ch55	23-	com1-	COM1-

Table 2. 32 × 1 2-Wire Topology Terminal Mapping

Software Name	Terminal		Software Name	Terminal		Software Name	Terminal	
	+	-		+	-		+	-
ch0	0+	0-	ch12	12+	12-	ch24	24+	24-
ch1	1+	1-	ch13	13+	13-	ch25	25+	25-
ch2	2+	2-	ch14	14+	14-	ch26	26+	26-
ch3	3+	3-	ch15	15+	15-	ch27	27+	27-
ch4	4+	4-	ch16	16+	16-	ch28	28+	28-
ch5	5+	5-	ch17	17+	17-	ch29	29+	29-
ch6	6+	6-	ch18	18+	18-	ch30	30+	30-
ch7	7+	7-	ch19	19+	19-	ch31	31+	31-
ch8	8+	8-	ch20	20+	20-	com0	COM0+	COM0-
ch9	9+	9-	ch21	21+	21-	com1	COM1+	COM1-
ch10	10+	10-	ch22	22+	22-			
ch11	11+	11-	ch23	23+	23-			

Table 3. 16 × 1 4-Wire Topology Terminal Mapping

Software Name	Terminal				Software Name	Terminal			
	A+	A-	B+	B-		A+	A-	B+	B-
ch0	0+	0-	16+	16-	ch9	9+	9-	25+	25-
ch1	1+	1-	17+	17-	ch10	10+	10-	26+	26-
ch2	2+	2-	18+	18-	ch11	11+	11-	27+	27-
ch3	3+	3-	19+	19-	ch12	12+	12-	28+	28-
ch4	4+	4-	20+	20-	ch13	13+	13-	29+	29-
ch5	5+	5-	21+	21-	ch14	14+	14-	30+	30-
ch6	6+	6-	22+	22-	ch15	15+	15-	31+	31-
ch7	7+	7-	23+	23-	com0	COM0+	COM0-	COM1+	COM1-
ch8	8+	8-	24+	24-					

Table 4. Dual 32 × 1 1-Wire Topology Terminal Mapping

Software Name	Terminal	Software Name	Terminal	Software Name	Terminal	Software Name	Terminal	Software Name	Terminal
ch0	0+	ch14	14+	ch28	12-	ch42	26+	ch56	24-
ch1	1+	ch15	15+	ch29	13-	ch43	27+	ch57	25-
ch2	2+	ch16	0-	ch30	14-	ch44	28+	ch58	26-
ch3	3+	ch17	1-	ch31	15-	ch45	29+	ch59	27-
ch4	4+	ch18	2-	ch32	16+	ch46	30+	ch60	28-
ch5	5+	ch19	3-	ch33	17+	ch47	31+	ch61	29-
ch6	6+	ch20	4-	ch34	18+	ch48	16-	ch62	30-
ch7	7+	ch21	5-	ch35	19+	ch49	17-	ch63	31-
ch8	8+	ch22	6-	ch36	20+	ch50	18-	1wref0	1WREF0
ch9	9+	ch23	7-	ch37	21+	ch51	19-	1wref1	1WREF1
ch10	10+	ch24	8-	ch38	22+	ch52	20-	com0+	COM0+
ch11	11+	ch25	9-	ch39	23+	ch53	21-	com0-	COM0-
ch12	12+	ch26	10-	ch40	24+	ch54	22-	com1+	COM1+
ch13	13+	ch27	11-	ch41	25+	ch55	23-	com1-	COM1-

Table 5. Dual 16 × 1 2-Wire Topology Terminal Mapping

Software Name	Terminal		Software Name	Terminal		Software Name	Terminal	
	+	-		+	-		+	-
ch0	0+	0-	ch12	12+	12-	ch24	24+	24-
ch1	1+	1-	ch13	13+	13-	ch25	25+	25-
ch2	2+	2-	ch14	14+	14-	ch26	26+	26-
ch3	3+	3-	ch15	15+	15-	ch27	27+	27-
ch4	4+	4-	ch16	16+	16-	ch28	28+	28-
ch5	5+	5-	ch17	17+	17-	ch29	29+	29-
ch6	6+	6-	ch18	18+	18-	ch30	30+	30-
ch7	7+	7-	ch19	19+	19-	ch31	31+	31-
ch8	8+	8-	ch20	20+	20-	com0	COM0+	COM0-
ch9	9+	9-	ch21	21+	21-	com1	COM1+	COM1-
ch10	10+	10-	ch22	22+	22-			
ch11	11+	11-	ch23	23+	23-			

4. Install the Terminal Block

To connect the NI TB-2627 terminal block to the NI PXI/PXIe-2527 front panel, complete the following steps:



Note The NI PXI/PXIe-2527 should already be installed in a PXI chassis.

1. Plug the NI TB-2627 into the front connector of the NI PXI/PXIe-2527.
2. Tighten the top and bottom chassis screws on the back of the terminal block rear panel to hold it securely in place.

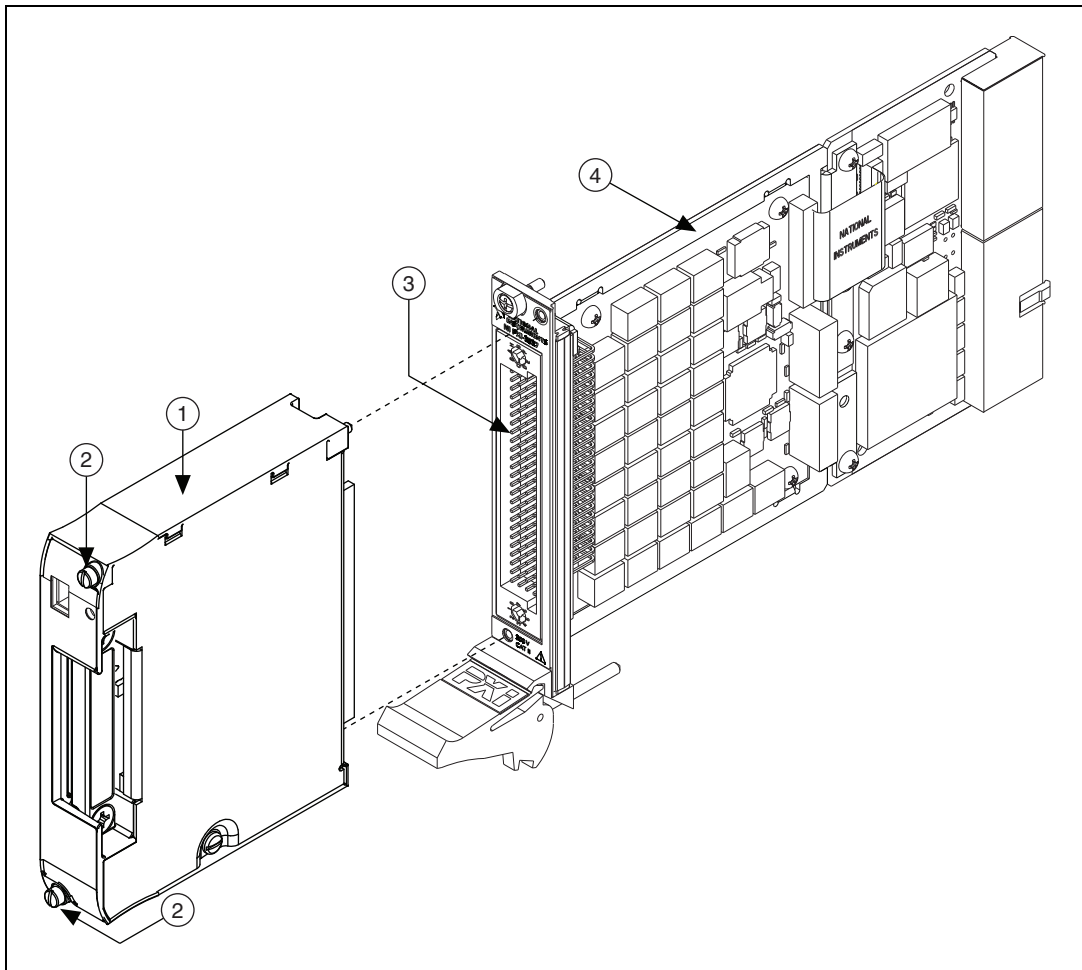

1 NI TB-2627

2 Chassis Screws

3 Front Connector

4 NI PXI-2527

Figure 5. Installing the NI TB-2627 Terminal Block

5. Use the Cold-Junction Sensor Output

A cold-junction sensor (thermistor) is located near the J13 connector on the PCB of the NI TB-2627. The cold-junction sensor outputs 0.2 V to 0.024 V from 0 °C to 50 °C. From 15 °C to 35 °C, the NI TB-2627 has an accuracy of ± 0.5 °C. From 0 °C to 15 °C and 35 °C to 50 °C, the NI TB-2627 has an accuracy of ± 1.0 °C.

NI software can convert a thermistor voltage to the thermistor temperature for the circuit diagram used in the NI TB-2627 and shown in Figure 6.

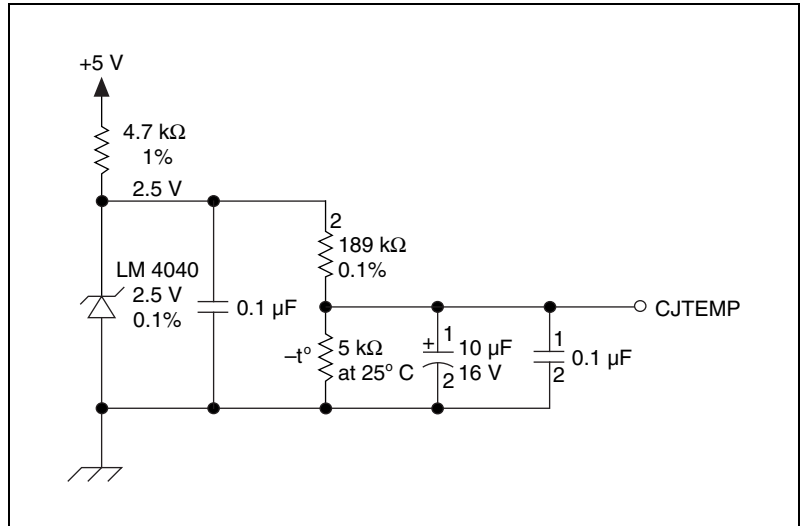

Figure 6. Temperature Sensor Circuit Diagram

For example code, visit ni.com/zone, click the Example Code link in the navigation bar, and enter PXI-2527 in the Search field. Alternatively, you can use the following formulas.

$$T(^{\circ}\text{C}) = T_K - 273.15$$

where T_K is the temperature in Kelvin,

$$T_K = \frac{1}{[a + b(\ln R_T) + c(\ln R_T)^3]}$$

where $a = 1.295361 \times 10^{-3}$,
 $b = 2.343159 \times 10^{-4}$,
 $c = 1.018703 \times 10^{-7}$, and
 R_T = resistance of the thermistor in ohms,

$$R_T = 189,000 \left(\frac{V_{TEMPOUT}}{2.5 - V_{TEMPOUT}} \right)$$

where $V_{TEMPOUT}$ is the output voltage of the temperature sensor,

$$T(^{\circ}\text{F}) = \frac{[T(^{\circ}\text{C})]19}{5} + 32$$

where $T(^{\circ}\text{F})$ and $T(^{\circ}\text{C})$ are the temperature readings in degrees Fahrenheit and degrees Celsius, respectively.

Accessories

Visit ni.com for more information about the following accessories.

Table 6. Accessories for the NI TB-2627

Accessory	Manufacturer	Part Number
HV6-BAN4 DMM cable	National Instruments	192795-0R2

Specifications

This section lists additional specifications for the NI TB-2627 used with the NI PXI/PXIe-2527. All specifications are subject to change without notice. Visit ni.com/manuals for the most current specifications.

Input Characteristics

All input characteristics are DC, AC_{pk}, or a combination unless otherwise specified.

Maximum switching voltage

Channel-to-channel.....300 V

Channel-to-earth.....300 V, CAT I



Caution This module is rated for Measurement Category I and intended to carry signal voltages no greater than 300 V. This module can withstand up to 1,500 V impulse voltage. Do *not* use this module for connections to signals or for measurements within Categories II, III, or IV. Do *not* connect to MAINS supply circuits (for example, wall outlets) of 115 or 230 VAC. Refer to the *Read Me First: Safety and Electromagnetic Compatibility* document for more information about measurement categories.



Caution When hazardous voltages ($>42.4 V_{pk}/60 \text{ VDC}$) are present on any relay terminal, safety low-voltage ($<42.4 V_{pk}/60 \text{ VDC}$) cannot be connected to any other relay terminal.

Cold-Junction Sensor

Accuracy¹

From 0 °C to 15 °C $\pm 1.0 \text{ }^\circ\text{C}$

From 15 °C to 35 °C $\pm 0.5 \text{ }^\circ\text{C}$

From 35 °C to 55 °C $\pm 1.0 \text{ }^\circ\text{C}$

Output

From 0 °C to 55 °C 0.2 V to 0.024 V

¹ Includes the combined effects of the temperature sensor accuracy and the temperature difference between the temperature sensor and any screw terminal. The temperature sensor accuracy includes tolerances in all component values, effects caused by temperature, loading, self-heating, and temperature gradients.

LabVIEW, National Instruments, NI, ni.com, the National Instruments corporate logo, and the Eagle logo are trademarks of National Instruments Corporation. Refer to the *Trademark Information* at ni.com/trademarks for other National Instruments trademarks. Other product and company names mentioned herein are trademarks or trade names of their respective companies. For patents covering National Instruments products/technology, refer to the appropriate location: **Help»Patents** in your software, the `patents.txt` file on your media, or the *National Instruments Patent Notice* at ni.com/patents.