

COMPREHENSIVE SERVICES

We offer competitive repair and calibration services, as well as easily accessible documentation and free downloadable resources.

SELL YOUR SURPLUS

We buy new, used, decommissioned, and surplus parts from every NI series. We work out the best solution to suit your individual needs.

 Sell For Cash  Get Credit  Receive a Trade-In Deal

OBSOLETE NI HARDWARE IN STOCK & READY TO SHIP

We stock **New**, **New Surplus**, **Refurbished**, and **Reconditioned** NI Hardware.



Bridging the gap between the manufacturer and your legacy test system.

 1-800-915-6216

 www.apexwaves.com

 sales@apexwaves.com

All trademarks, brands, and brand names are the property of their respective owners.

Request a Quote

 **CLICK HERE**

TB-2640

INSTALLATION INSTRUCTIONS

NI SCB-264X

Shielded Connector Block for the NI PXI/PXIe-2532/2532B

このドキュメントには、日本語ページも含まれています。

This document describes how to install and connect signals to the National Instruments SCB-264X shielded connector block. Use the NI SCB-264X to interface individual signal wires to the rows and columns of the NI PXI/PXIe-2532/2532B matrices.

The NI SCB-264X has five ribbon cable connectors for connecting to the NI TB-2640/2641/2642/2643/2644 (NI TB-264X) and NI TB-2640B/2641B/2642B/2643B/2644B/2646B (NI TB-264XB) connector blocks and screw terminals for connecting signals. The NI SCB-264X supports most NI PXI/PXIe-2532/2532B topologies that are configured with the NI TB-264X/264XB. The NI SCB-264X can be used alone, or it can be rack-mounted using the included DIN rail-mounting kit.



Note References to the NI TB-264X/264XB in this document do not include the NI TB-2645/2645B. For more information on connecting the SCB-264X with the NI TB-2645/2645B, visit ni.com/info and enter the Info Code SCB264x.

Visit ni.com/switches for information about other switching solutions.



Caution This product is rated for 60 VDC, CAT I. Refer to the *Input Characteristics* section for more information.



Caution The maximum voltage on the NI SCB-264X is 60 VDC. When the NI SCB-264X is used with the NI 2532/2532B, the maximum switching voltage must be limited to 60 V. Refer to the *Specifications* section for more information.

Conventions

The following conventions are used in this guide:

»

The » symbol leads you through nested menu items and dialog box options to a final action. The sequence **Options»Settings»General** directs you to pull down the **Options** menu, select the **Settings** item, and select **General** from the last dialog box.



This icon denotes a note, which alerts you to important information.



This icon denotes a caution, which advises you of precautions to take to avoid injury, data loss, or a system crash. When this symbol is marked on a product, refer to the *Read Me First: Safety and Electromagnetic Compatibility* document for information about precautions to take.

bold

Bold text denotes items that you must select or click in the software, such as menu items and dialog box options. Bold text also denotes parameter names.

italic

Italic text denotes variables, emphasis, a cross-reference, or an introduction to a key concept. Italic text also denotes text that is a placeholder for a word or value that you must supply.

monospace

Text in this font denotes text or characters that you should enter from the keyboard, sections of code, programming examples, and syntax examples. This font is also used for the proper names of disk drives, paths, directories, programs, subprograms, subroutines, device names, functions, operations, variables, filenames and extensions.

1. Unpack the Shielded Connector Block

Remove the NI SCB-264X from the package and inspect it for loose components or any sign of damage. Notify NI if the NI SCB-264X appears damaged in any way.



Caution Do *not* install a damaged shielded connector block into your system.

2. Verify the Components

To install and use the NI SCB-264X you need the following items:

- NI SCB-264X shielded connector block
- NI PXI/PXIe-2532/2532B switch module
- One of the NI TB-264X/264XB connector block accessories listed in Table 1 or Table 2
- Installation instructions for the NI TB-264X/264XB you are using, accessible at ni.com/manuals
- Ribbon cables (not included)



Note Refer to Table 1 for information about ordering ribbon cables for the NI SCB-264X for use with the NI PXI/PXIe-2532. Refer to Table 2 for information about ordering ribbon cables for the NI SCB-264X for use with the NI PXI/PXIe-2532B.

- 1/8 in. flathead screwdriver
- #1 Phillips screwdriver
- Long-nose pliers
- Wire cutter
- Wire insulation stripper

Table 1. Accessories for the NI SCB-264X to be used with the NI PXI/PXIe-2532

Accessory	Part Number
Row and column cable kit for the NI TB-264X terminal blocks (60 V)	779346-01
NI TB-2640 shielded connector block (4 × 128 1-wire matrix)	779056-01
NI TB-2640 shielded connector block, with protection resistance	779056-02
NI TB-2641 shielded connector block (8 × 64 1-wire matrix)	779056-03
NI TB-2641 shielded connector block, with protection resistance	779056-04
NI TB-2642 shielded connector block (16 × 32 1-wire matrix)	779056-05
NI TB-2642 shielded connector block, with protection resistance	779056-06
NI TB-2643 shielded connector block (4 × 64 2-wire matrix or dual 4 × 64 1-wire matrix)	779056-07
NI TB-2643 shielded connector block, with protection resistance	779056-08

Table 1. Accessories for the NI SCB-264X (Continued) to be used with the NI PXI/PXIe-2532

Accessory	Part Number
NI TB-2644 shielded connector block (8 × 32 2-wire matrix or dual 8 × 32 1-wire matrix)	779056-09
NI TB-2644 shielded connector block, with protection resistance	779056-10

Table 2. Accessories for the NI SCB-264X to be used with the NI PXI/PXIe-2532B

Accessory	Part Number
Row and column cable kit for the NI TB-264XB terminal blocks (60 V)	779346-01
NI TB-2640B terminal block (1-wire 4 × 128 matrix)	782385-01
NI TB-2640B terminal block, with protection resistance	782385-02
NI TB-2641B terminal block (1-wire 8 × 64 matrix)	782385-03
NI TB-2641B terminal block, with protection resistance	782385-04
NI TB-2642B terminal block (1-wire 16 × 32 matrix)	782385-05
NI TB-2642B terminal block, with protection resistance	782385-06
NI TB-2643B terminal block (2-wire 4 × 64 matrix or 1-wire dual 4 × 64 matrix)	782385-07
NI TB-2643B terminal block, with protection resistance	782385-08
NI TB-2644B terminal block (2-wire 8 × 32 matrix or 1-wire dual 8 × 32 matrix)	782385-09
NI TB-2644B terminal block, with protection resistance	782385-10

3. Install the DIN-Rail Mounting Bracket (Optional)

If you prefer DIN-rail mounting instead of stand-alone operation, the NI SCB-264X is packaged with an optional DIN-rail mounting bracket. The bracket can be installed horizontally or vertically to the bottom of the NI SCB-264X. To install the mounting bracket, align the bracket with the appropriate horizontal or vertical holes, and secure the bracket to the NI SCB-264X using the two included screws.

4. Connect the NI SCB-264X to the NI TB-264X/264XB

The NI TB-264X/264XB connects to and configures the NI PXI/PXIe-2532/2532B switch module into different topologies. To use the NI SCB-264X, you *must* connect to the NI PXI/PXIe-2532/2532B through one of the NI TB-264X/264XB terminal block accessories listed in Table 1. To connect the NI SCB-264X to the NI TB-264X/264XB, refer to Figures 1 and 2 while completing the following steps:

1. Gather the ribbon cables required for connecting the NI SCB-264X to the NI TB-264X/264XB. Depending on which NI TB-264X/264XB you are using, you may have up to four column cables (34-conductor ribbon cables with 2×17 connectors) and one row cable (16-conductor ribbon cable with a 2×8 connector). Refer to the installation instructions for your NI TB-264X/264XB for more information about the required cables.
2. Follow the steps in the NI TB-264X/264XB installation instructions to connect the ribbon cables to the NI TB-264X/264XB. Note the location of each cable in the NI TB-264X/264XB. Specifically note the reference designator for each connector to which the cable is attached and for NI TB-264X accessories note whether the cable is connected to the lower or upper column connection board.
3. To access the ribbon cable connectors on the NI SCB-264X, insert a 1/8 in. flathead screwdriver into the groove on the edge of the NI SCB-264X.
4. Carefully turn the screwdriver counterclockwise until the top cover of the NI SCB-264X unsnaps.
5. Remove the top cover.
6. Inside the NI SCB-264X there are two strain-relief bars. Loosen the strain-relief screws on the strain-relief bar closest to the ribbon cable connectors.
7. Route the ribbon cables through the strain-relief opening.
8. Attach the ribbon cables to the column and row ribbon cable connectors appropriate to the terminal block you are using. To secure the cables, ensure that the locking mechanism engages. Refer to tables 3 and 4 for connection information. If these connections are incorrect, Tables 5 through 12 are invalid.



Note In tables 3 and 4, “Upper” indicates a connector on the upper column connection board and “Lower” indicates a connector on the lower column connection board.

Table 3. Connections for NI PXI/PXIe-2532

SCB-264X	TB-2640	TB-2641	TB-2642	TB-2643	TB-2644
A	J3 or J4	J3 or J2	J3 or J2	J3 or J4	J3 or J2
B/Lower J3	Lower J3	J3	J3	Lower J3	J3
C/Lower J2	Lower J2	J2	NC	Lower J2	J2
D/Upper J2	Upper J2	NC	NC	Upper J2	NC
E/Upper J3	Upper J3	NC	NC	Upper J3	NC

Table 4. Connections for NI PXI/PXIe-2532B

SCB-264X	TB-2640B	TB-2641B	TB-2642B	TB-2643B	TB-2644B	TB-2646B
A	J4 or J5	J4 or J5	J8 or J9	J4 or J5	J4 or J5	J4
B/Lower J3	J3	J3	J3	J3	J3	J3
C/Lower J2	J2	J2	NC	J2	J2	J2
D/Upper J2	J12	NC	NC	J12	NC	J12
E/Upper J3	J13	NC	NC	J13	NC	J13

9. To connect signal wires to the NI SCB-264X, refer to step [5. Connect Signals](#). Otherwise, replace the top cover, and refer to step [1. Unpack the Shielded Connector Block](#).

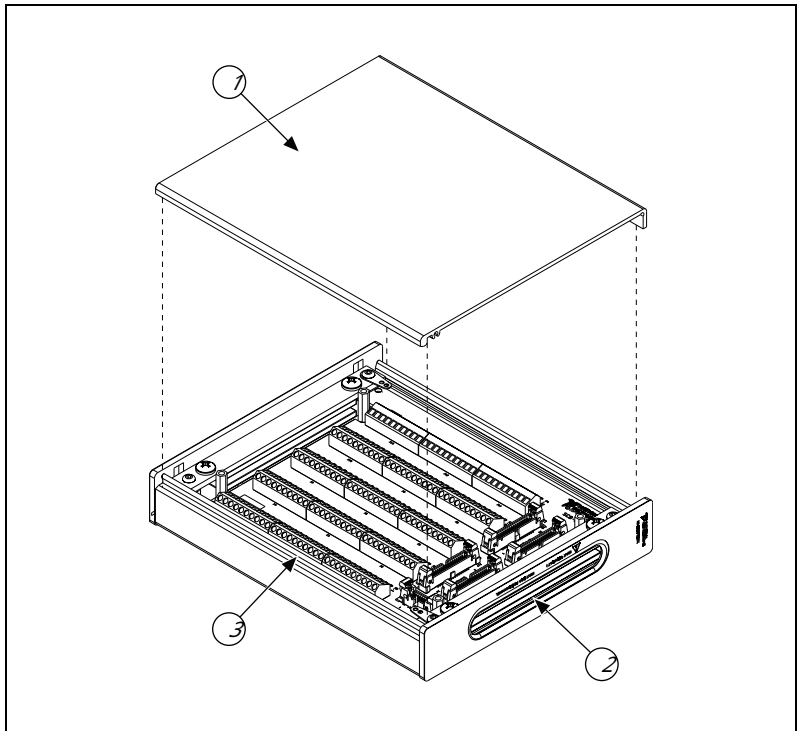

- | | |
|-------------------------|--------------------------|
| 1 Top Cover | 3 Groove for Screwdriver |
| 2 Strain-Relief Opening | |

Figure 1. NI SCB-264X Shielded Connector Block

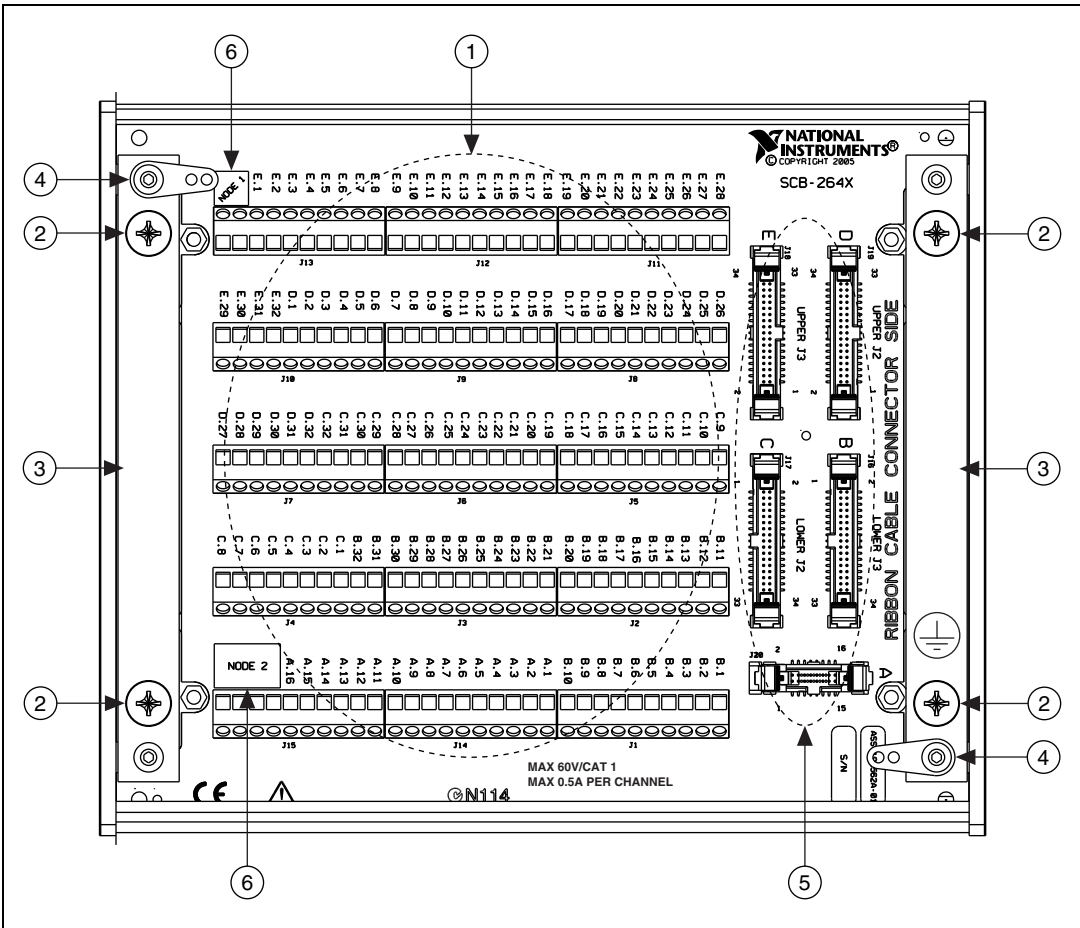

- | | |
|------------------------|---------------------------|
| 1 Screw Terminals | 4 Safety Ground Lug |
| 2 Strain-Relief Screws | 5 Ribbon Cable Connectors |
| 3 Strain-Relief Bar | 6 Node Terminals |

Figure 2. NI SCB-264X Parts Locator Diagram

5. Connect Signals

To connect signals to the NI SCB-264X, refer to Figures 1 and 2 while completing the following steps:

1. Prepare the signal wire by stripping the insulation no more than 7 mm from the end of the wire.
2. Loosen the strain-relief screws on the strain-relief bar closest to the screw terminals.
3. Route the signal wires through the strain-relief opening.
4. Based on the NI TB-264X/264XB you are using, refer to the appropriate table (Tables 5 through 13) to determine which screw terminal to connect the signal wire.
5. Insert the stripped end of the wire fully into the terminal. Secure the wire by tightening the screw of the terminal.



Caution No bare wire should extend past the screw terminal. Exposed wire increases the risk of a short-circuit causing a failure.

6. Connect the protective earth (PE) ground to a safety ground lug.
7. Tighten the screws on the strain-relief assemblies to secure the cables.
8. Replace the top cover.



Note As illustrated in Figure 2, the NI SCB-264X contains six unused screw terminals, *Node 1* and *Node 2*, that you can use to assist in your signal/ground connections. Node 1 consists of two screw terminals that are connected to each other but are *not* connected to any other screw terminals; Node 2 consists of four screw terminals that are connected to each other but are *not* connected to any other screw terminals. Node 1 and Node 2 are *not* connected together. Use of the node terminals is optional.

Tables 5 through 13 illustrate the wiring configurations available for the NI SCB-264X.

Table 5. 1-Wire 4 × 128 Configuration (NI TB-2640/2640B)

SCB-264X Name	Channel Name	SCB-264X Name	Channel Name	SCB-264X Name	Channel Name	SCB-264X Name	Channel Name	SCB-264X Name	Channel Name
E.28	C100	D.26	C70	C.09	C40	B.11	C10	B.01	C0
E.27	C101	D.25	C71	C.10	C41	B.12	C11	B.02	C1
E.26	C102	D.24	C72	C.11	C42	B.13	C12	B.03	C2
E.25	C103	D.23	C73	C.12	C43	B.14	C13	B.04	C3
E.24	C104	D.22	C74	C.13	C44	B.15	C14	B.05	C4
E.23	C105	D.21	C75	C.14	C45	B.16	C15	B.06	C5
E.22	C106	D.20	C76	C.15	C46	B.17	C16	B.07	C6
E.21	C107	D.19	C77	C.16	C47	B.18	C17	B.08	C7
E.20	C108	D.18	C78	C.17	C48	B.19	C18	B.09	C8
E.19	C109	D.17	C79	C.18	C49	B.20	C19	B.10	C9
E.18	C110	D.16	C80	C.19	C50	B.21	C20	A.01	R0
E.17	C111	D.15	C81	C.20	C51	B.22	C21	A.02	R1
E.16	C112	D.14	C82	C.21	C52	B.23	C22	A.03	R2
E.15	C113	D.13	C83	C.22	C53	B.24	C23	A.04	R3
E.14	C114	D.12	C84	C.23	C54	B.25	C24	A.05	NC
E.13	C115	D.11	C85	C.24	C55	B.26	C25	A.06	NC
E.12	C116	D.10	C86	C.25	C56	B.27	C26	A.07	NC
E.11	C117	D.09	C87	C.26	C57	B.28	C27	A.08	NC
E.10	C118	D.08	C88	C.27	C58	B.29	C28	A.09	NC
E.09	C119	D.07	C89	C.28	C59	B.30	C29	A.10	NC
E.08	C120	D.06	C90	C.29	C60	B.31	C30	A.11	NC
E.07	C121	D.05	C91	C.30	C61	B.32	C31	A.12	NC
E.06	C122	D.04	C92	C.31	C62	C.01	C32	A.13	NC
E.05	C123	D.03	C93	C.32	C63	C.02	C33	A.14	NC
E.04	C124	D.02	C94	D.32	C64	C.03	C34	A.15	NC
E.03	C125	D.01	C95	D.31	C65	C.04	C35	A.16	NC
E.02	C126	E.32	C96	D.30	C66	C.05	C36	Node 2	NC ²
E.01	C127	E.31	C97	D.29	C67	C.06	C37	Node 2	NC ²
Node 1	NC ¹	E.30	C98	D.28	C68	C.07	C38	Node 2	NC ²
Node 1	NC ¹	E.29	C99	D.27	C69	C.08	C39	Node 2	NC ²

NC denotes a channel with no connection.

¹ The two Node 1 terminals are connected.

² The four Node 2 terminals are connected.

Table 6. 1-Wire 8 × 64 Configuration (NI TB-2641/2641B)

SCB-264X Name	Channel Name	SCB-264X Name	Channel Name	SCB-264X Name	Channel Name	SCB-264X Name	Channel Name	SCB-264X Name	Channel Name
E.28	NC	D.26	NC	C.09	C40	B.11	C10	B.01	C0
E.27	NC	D.25	NC	C.10	C41	B.12	C11	B.02	C1
E.26	NC	D.24	NC	C.11	C42	B.13	C12	B.03	C2
E.25	NC	D.23	NC	C.12	C43	B.14	C13	B.04	C3
E.24	NC	D.22	NC	C.13	C44	B.15	C14	B.05	C4
E.23	NC	D.21	NC	C.14	C45	B.16	C15	B.06	C5
E.22	NC	D.20	NC	C.15	C46	B.17	C16	B.07	C6
E.21	NC	D.19	NC	C.16	C47	B.18	C17	B.08	C7
E.20	NC	D.18	NC	C.17	C48	B.19	C18	B.09	C8
E.19	NC	D.17	NC	C.18	C49	B.20	C19	B.10	C9
E.18	NC	D.16	NC	C.19	C50	B.21	C20	A.01	R0
E.17	NC	D.15	NC	C.20	C51	B.22	C21	A.02	R1
E.16	NC	D.14	NC	C.21	C52	B.23	C22	A.03	R2
E.15	NC	D.13	NC	C.22	C53	B.24	C23	A.04	R3
E.14	NC	D.12	NC	C.23	C54	B.25	C24	A.05	R4
E.13	NC	D.11	NC	C.24	C55	B.26	C25	A.06	R5
E.12	NC	D.10	NC	C.25	C56	B.27	C26	A.07	R6
E.11	NC	D.09	NC	C.26	C57	B.28	C27	A.08	R7
E.10	NC	D.08	NC	C.27	C58	B.29	C28	A.09	NC
E.09	NC	D.07	NC	C.28	C59	B.30	C29	A.10	NC
E.08	NC	D.06	NC	C.29	C60	B.31	C30	A.11	NC
E.07	NC	D.05	NC	C.30	C61	B.32	C31	A.12	NC
E.06	NC	D.04	NC	C.31	C62	C.01	C32	A.13	NC
E.05	NC	D.03	NC	C.32	C63	C.02	C33	A.14	NC
E.04	NC	D.02	NC	D.32	NC	C.03	C34	A.15	NC
E.03	NC	D.01	NC	D.31	NC	C.04	C35	A.16	NC
E.02	NC	E.32	NC	D.30	NC	C.05	C36	Node 2	NC ²
E.01	NC	E.31	NC	D.29	NC	C.06	C37	Node 2	NC ²
Node 1	NC ¹	E.30	NC	D.28	NC	C.07	C38	Node 2	NC ²
Node 1	NC ¹	E.29	NC	D.27	NC	C.08	C39	Node 2	NC ²

NC denotes a channel with no connection.

¹ The two Node 1 terminals are connected.

² The four Node 2 terminals are connected.

Table 7. 1-Wire 16 × 32 Configuration (NI TB-2642/2642B)

SCB-264X Name	Channel Name	SCB-264X Name	Channel Name	SCB-264X Name	Channel Name	SCB-264X Name	Channel Name	SCB-264X Name	Channel Name
E.28	NC	D.26	NC	C.09	NC	B.11	C10	B.01	C0
E.27	NC	D.25	NC	C.10	NC	B.12	C11	B.02	C1
E.26	NC	D.24	NC	C.11	NC	B.13	C12	B.03	C2
E.25	NC	D.23	NC	C.12	NC	B.14	C13	B.04	C3
E.24	NC	D.22	NC	C.13	NC	B.15	C14	B.05	C4
E.23	NC	D.21	NC	C.14	NC	B.16	C15	B.06	C5
E.22	NC	D.20	NC	C.15	NC	B.17	C16	B.07	C6
E.21	NC	D.19	NC	C.16	NC	B.18	C17	B.08	C7
E.20	NC	D.18	NC	C.17	NC	B.19	C18	B.09	C8
E.19	NC	D.17	NC	C.18	NC	B.20	C19	B.10	C9
E.18	NC	D.16	NC	C.19	NC	B.21	C20	A.01	R0
E.17	NC	D.15	NC	C.20	NC	B.22	C21	A.02	R1
E.16	NC	D.14	NC	C.21	NC	B.23	C22	A.03	R2
E.15	NC	D.13	NC	C.22	NC	B.24	C23	A.04	R3
E.14	NC	D.12	NC	C.23	NC	B.25	C24	A.05	R4
E.13	NC	D.11	NC	C.24	NC	B.26	C25	A.06	R5
E.12	NC	D.10	NC	C.25	NC	B.27	C26	A.07	R6
E.11	NC	D.09	NC	C.26	NC	B.28	C27	A.08	R7
E.10	NC	D.08	NC	C.27	NC	B.29	C28	A.09	R8
E.09	NC	D.07	NC	C.28	NC	B.30	C29	A.10	R9
E.08	NC	D.06	NC	C.29	NC	B.31	C30	A.11	R10
E.07	NC	D.05	NC	C.30	NC	B.32	C31	A.12	R11
E.06	NC	D.04	NC	C.31	NC	C.01	NC	A.13	R12
E.05	NC	D.03	NC	C.32	NC	C.02	NC	A.14	R13
E.04	NC	D.02	NC	D.32	NC	C.03	NC	A.15	R14
E.03	NC	D.01	NC	D.31	NC	C.04	NC	A.16	R15
E.02	NC	E.32	NC	D.30	NC	C.05	NC	Node 2	NC ²
E.01	NC	E.31	NC	D.29	NC	C.06	NC	Node 2	NC ²
Node 1	NC ¹	E.30	NC	D.28	NC	C.07	NC	Node 2	NC ²
Node 1	NC ¹	E.29	NC	D.27	NC	C.08	NC	Node 2	NC ²

NC denotes a channel with no connection.

¹ The two Node 1 terminals are connected.

² The four Node 2 terminals are connected.

Table 8. 2-Wire 4 × 64 Configuration (NI TB-2643/2643B)

SCB-264X Name	Channel Name	SCB-264X Name	Channel Name	SCB-264X Name	Channel Name	SCB-264X Name	Channel Name	SCB-264X Name	Channel Name
E.28	C50+	D.26	C35+	C.09	C20+	B.11	C5+	B.01	C0+
E.27	C50-	D.25	C35-	C.10	C20-	B.12	C5-	B.02	C0-
E.26	C51+	D.24	C36+	C.11	C21+	B.13	C6+	B.03	C1+
E.25	C51-	D.23	C36-	C.12	C21-	B.14	C6-	B.04	C1-
E.24	C52+	D.22	C37+	C.13	C22+	B.15	C7+	B.05	C2+
E.23	C52-	D.21	C37-	C.14	C22-	B.16	C7-	B.06	C2-
E.22	C53+	D.20	C38+	C.15	C23+	B.17	C8+	B.07	C3+
E.21	C53-	D.19	C38-	C.16	C23-	B.18	C8-	B.08	C3-
E.20	C54+	D.18	C39+	C.17	C24+	B.19	C9+	B.09	C4+
E.19	C54-	D.17	C39-	C.18	C24-	B.20	C9-	B.10	C4-
E.18	C55+	D.16	C40+	C.19	C25+	B.21	C10+	A.01	R0+
E.17	C55-	D.15	C40-	C.20	C25-	B.22	C10-	A.02	R0-
E.16	C56+	D.14	C41+	C.21	C26+	B.23	C11+	A.03	R1+
E.15	C56-	D.13	C41-	C.22	C26-	B.24	C11-	A.04	R1-
E.14	C57+	D.12	C42+	C.23	C27+	B.25	C12+	A.05	R2+
E.13	C57-	D.11	C42-	C.24	C27-	B.26	C12-	A.06	R2-
E.12	C58+	D.10	C43+	C.25	C28+	B.27	C13+	A.07	R3+
E.11	C58-	D.09	C43-	C.26	C28-	B.28	C13-	A.08	R3-
E.10	C59+	D.08	C44+	C.27	C29+	B.29	C14+	A.09	NC
E.09	C59-	D.07	C44-	C.28	C29-	B.30	C14-	A.10	NC
E.08	C60+	D.06	C45+	C.29	C30+	B.31	C15+	A.11	NC
E.07	C60-	D.05	C45-	C.30	C30-	B.32	C15-	A.12	NC
E.06	C61+	D.04	C46+	C.31	C31+	C.01	C16+	A.13	NC
E.05	C61-	D.03	C46-	C.32	C31-	C.02	C16-	A.14	NC
E.04	C62+	D.02	C47+	D.32	C32+	C.03	C17+	A.15	NC
E.03	C62-	D.01	C47-	D.31	C32-	C.04	C17-	A.16	NC
E.02	C63+	E.32	C48+	D.30	C33+	C.05	C18+	Node 2	NC ²
E.01	C63-	E.31	C48-	D.29	C33-	C.06	C18-	Node 2	NC ²
Node 1	NC ¹	E.30	C49+	D.28	C34+	C.07	C19+	Node 2	NC ²
Node 1	NC ¹	E.29	C49-	D.27	C34-	C.08	C19-	Node 2	NC ²

NC denotes a channel with no connection.

¹ The two Node 1 terminals are connected.

² The four Node 2 terminals are connected.

Table 9. 1-Wire Dual 4 × 64 Configuration (NI TB-2643/2643B)

SCB-264X Name	Channel Name	SCB-264X Name	Channel Name	SCB-264X Name	Channel Name	SCB-264X Name	Channel Name	SCB-264X Name	Channel Name
E.28	B0C50	D.26	B0C35	C.09	B0C20	B.11	B0C5	B.01	B0C0
E.27	B1C50	D.25	B1C35	C.10	B1C20	B.12	B1C5	B.02	B1C0
E.26	B0C51	D.24	B0C36	C.11	B0C21	B.13	B0C6	B.03	B0C1
E.25	B1C51	D.23	B1C36	C.12	B1C21	B.14	B1C6	B.04	B1C1
E.24	B0C52	D.22	B0C37	C.13	B0C22	B.15	B0C7	B.05	B0C2
E.23	B1C52	D.21	B1C37	C.14	B1C22	B.16	B1C7	B.06	B1C2
E.22	B0C53	D.20	B0C38	C.15	B0C23	B.17	B0C8	B.07	B0C3
E.21	B1C53	D.19	B1C38	C.16	B1C23	B.18	B1C8	B.08	B1C3
E.20	B0C54	D.18	B0C39	C.17	B0C24	B.19	B0C9	B.09	B0C4
E.19	B1C54	D.17	B1C39	C.18	B1C24	B.20	B1C9	B.10	B1C4
E.18	B0C55	D.16	B0C40	C.19	B0C25	B.21	B0C10	A.01	B0R0
E.17	B1C55	D.15	B1C40	C.20	B1C25	B.22	B1C10	A.02	B1R0
E.16	B0C56	D.14	B0C41	C.21	B0C26	B.23	B0C11	A.03	B0R1
E.15	B1C56	D.13	B1C41	C.22	B1C26	B.24	B1C11	A.04	B1R1
E.14	B0C57	D.12	B0C42	C.23	B0C27	B.25	B0C12	A.05	B0R2
E.13	B1C57	D.11	B1C42	C.24	B1C27	B.26	B1C12	A.06	B1R2
E.12	B0C58	D.10	B0C43	C.25	B0C28	B.27	B0C13	A.07	B0R3
E.11	B1C58	D.09	B1C43	C.26	B1C28	B.28	B1C13	A.08	B1R3
E.10	B0C59	D.08	B0C44	C.27	B0C29	B.29	B0C14	A.09	NC
E.09	B1C59	D.07	B1C44	C.28	B1C29	B.30	B1C14	A.10	NC
E.08	B0C60	D.06	B0C45	C.29	B0C30	B.31	B0C15	A.11	NC
E.07	B1C60	D.05	B1C45	C.30	B1C30	B.32	B1C15	A.12	NC
E.06	B0C61	D.04	B0C46	C.31	B0C31	C.01	B0C16	A.13	NC
E.05	B1C61	D.03	B1C46	C.32	B1C31	C.02	B1C16	A.14	NC
E.04	B0C62	D.02	B0C47	D.32	B0C32	C.03	B0C17	A.15	NC
E.03	B1C62	D.01	B1C47	D.31	B1C32	C.04	B1C17	A.16	NC
E.02	B0C63	E.32	B0C48	D.30	B0C33	C.05	B0C18	Node 2	NC ²
E.01	B1C63	E.31	B1C48	D.29	B1C33	C.06	B1C18	Node 2	NC ²
Node 1	NC ¹	E.30	B0C49	D.28	B0C34	C.07	B0C19	Node 2	NC ²
Node 1	NC ¹	E.29	B1C49	D.27	B1C34	C.08	B1C19	Node 2	NC ²

NC denotes a channel with no connection.

¹ The two Node 1 terminals are connected.

² The four Node 2 terminals are connected.

Table 10. 2-Wire 8 × 32 Configuration (NI TB-2644/2644B)

SCB-264X Name	Channel Name	SCB-264X Name	Channel Name	SCB-264X Name	Channel Name	SCB-264X Name	Channel Name	SCB-264X Name	Channel Name
E.28	NC	D.26	NC	C.09	C20+	B.11	C5+	B.01	C0+
E.27	NC	D.25	NC	C.10	C20-	B.12	C5-	B.02	C0-
E.26	NC	D.24	NC	C.11	C21+	B.13	C6+	B.03	C1+
E.25	NC	D.23	NC	C.12	C21-	B.14	C6-	B.04	C1-
E.24	NC	D.22	NC	C.13	C22+	B.15	C7+	B.05	C2+
E.23	NC	D.21	NC	C.14	C22-	B.16	C7-	B.06	C2-
E.22	NC	D.20	NC	C.15	C23+	B.17	C8+	B.07	C3+
E.21	NC	D.19	NC	C.16	C23-	B.18	C8-	B.08	C3-
E.20	NC	D.18	NC	C.17	C24+	B.19	C9+	B.09	C4+
E.19	NC	D.17	NC	C.18	C24-	B.20	C9-	B.10	C4-
E.18	NC	D.16	NC	C.19	C25+	B.21	C10+	A.01	R0+
E.17	NC	D.15	NC	C.20	C25-	B.22	C10-	A.02	R0-
E.16	NC	D.14	NC	C.21	C26+	B.23	C11+	A.03	R1+
E.15	NC	D.13	NC	C.22	C26-	B.24	C11-	A.04	R1-
E.14	NC	D.12	NC	C.23	C27+	B.25	C12+	A.05	R2+
E.13	NC	D.11	NC	C.24	C27-	B.26	C12-	A.06	R2-
E.12	NC	D.10	NC	C.25	C28+	B.27	C13+	A.07	R3+
E.11	NC	D.09	NC	C.26	C28-	B.28	C13-	A.08	R3-
E.10	NC	D.08	NC	C.27	C29+	B.29	C14+	A.09	R4+
E.09	NC	D.07	NC	C.28	C29-	B.30	C14-	A.10	R4-
E.08	NC	D.06	NC	C.29	C30+	B.31	C15+	A.11	R5+
E.07	NC	D.05	NC	C.30	C30-	B.32	C15-	A.12	R5-
E.06	NC	D.04	NC	C.31	C31+	C.01	C16+	A.13	R6+
E.05	NC	D.03	NC	C.32	C31-	C.02	C16-	A.14	R6-
E.04	NC	D.02	NC	D.32	NC	C.03	C17+	A.15	R7+
E.03	NC	D.01	NC	D.31	NC	C.04	C17-	A.16	R7-
E.02	NC	E.32	NC	D.30	NC	C.05	C18+	Node 2	NC ²
E.01	NC	E.31	NC	D.29	NC	C.06	C18-	Node 2	NC ²
Node 1	NC ¹	E.30	NC	D.28	NC	C.07	C19+	Node 2	NC ²
Node 1	NC ¹	E.29	NC	D.27	NC	C.08	C19-	Node 2	NC ²

NC denotes a channel with no connection.

¹ The two Node 1 terminals are connected.

² The four Node 2 terminals are connected.

Table 11. 1-Wire Dual 8 × 32 Configuration (NI TB-2644/2644B)

SCB-264X Name	Channel Name	SCB-264X Name	Channel Name	SCB-264X Name	Channel Name	SCB-264X Name	Channel Name	SCB-264X Name	Channel Name
E.28	NC	D.26	NC	C.09	B0C20	B.11	B0C5	B.01	B0C0
E.27	NC	D.25	NC	C.10	B1C20	B.12	B1C5	B.02	B1C0
E.26	NC	D.24	NC	C.11	B0C21	B.13	B0C6	B.03	B0C1
E.25	NC	D.23	NC	C.12	B1C21	B.14	B1C6	B.04	B1C1
E.24	NC	D.22	NC	C.13	B0C22	B.15	B0C7	B.05	B0C2
E.23	NC	D.21	NC	C.14	B1C22	B.16	B1C7	B.06	B1C2
E.22	NC	D.20	NC	C.15	B0C23	B.17	B0C8	B.07	B0C3
E.21	NC	D.19	NC	C.16	B1C23	B.18	B1C8	B.08	B1C3
E.20	NC	D.18	NC	C.17	B0C24	B.19	B0C9	B.09	B0C4
E.19	NC	D.17	NC	C.18	B1C24	B.20	B1C9	B.10	B1C4
E.18	NC	D.16	NC	C.19	B0C25	B.21	B0C10	A.01	B0R0
E.17	NC	D.15	NC	C.20	B1C25	B.22	B1C10	A.02	B1R0
E.16	NC	D.14	NC	C.21	B0C26	B.23	B0C11	A.03	B0R1
E.15	NC	D.13	NC	C.22	B1C26	B.24	B1C11	A.04	B1R1
E.14	NC	D.12	NC	C.23	B0C27	B.25	B0C12	A.05	B0R2
E.13	NC	D.11	NC	C.24	B1C27	B.26	B1C12	A.06	B1R2
E.12	NC	D.10	NC	C.25	B0C28	B.27	B0C13	A.07	B0R3
E.11	NC	D.09	NC	C.26	B1C28	B.28	B1C13	A.08	B1R3
E.10	NC	D.08	NC	C.27	B0C29	B.29	B0C14	A.09	B0R4
E.09	NC	D.07	NC	C.28	B1C29	B.30	B1C14	A.10	B1R4
E.08	NC	D.06	NC	C.29	B0C30	B.31	B0C15	A.11	B0R5
E.07	NC	D.05	NC	C.30	B1C30	B.32	B1C15	A.12	B1R5
E.06	NC	D.04	NC	C.31	B0C31	C.01	B0C16	A.13	B0R6
E.05	NC	D.03	NC	C.32	B1C31	C.02	B1C16	A.14	B1R6
E.04	NC	D.02	NC	D.32	NC	C.03	B0C17	A.15	B0R7
E.03	NC	D.01	NC	D.31	NC	C.04	B1C17	A.16	B1R7
E.02	NC	E.32	NC	D.30	NC	C.05	B0C18	Node 2	NC ²
E.01	NC	E.31	NC	D.29	NC	C.06	B1C18	Node 2	NC ²
Node 1	NC ¹	E.30	NC	D.28	NC	C.07	B0C19	Node 2	NC ²
Node 1	NC ¹	E.29	NC	D.27	NC	C.08	B1C19	Node 2	NC ²

NC denotes a channel with no connection.

¹ The two Node 1 terminals are connected.

² The four Node 2 terminals are connected.

Table 12. 2-Wire Dual 4 × 32 Configuration (NI TB-2646B)

SCB-264X Name	Channel Name	SCB-264X Name	Channel Name	SCB-264X Name	Channel Name	SCB-264X Name	Channel Name	SCB-264X Name	Channel Name
E.28	B1C18+	D.26	B1C3+	C.09	B0C20+	B.11	B0C5+	B.01	B0C0+
E.27	B1C18-	D.25	B1C3-	C.10	B0C20-	B.12	B0C5-	B.02	B0C0-
E.26	B1C19+	D.24	B1C4+	C.11	B0C21+	B.13	B0C6+	B.03	B0C1+
E.25	B1C19-	D.23	B1C4-	C.12	B0C21-	B.14	B0C6-	B.04	B0C1-
E.24	B1C20+	D.22	B1C5+	C.13	B0C22+	B.15	B0C7+	B.05	B0C2+
E.23	B1C20-	D.21	B1C5-	C.14	B0C22-	B.16	B0C7-	B.06	B0C2-
E.22	B1C21+	D.20	B1C6+	C.15	B0C23+	B.17	B0C8+	B.07	B0C3+
E.21	B1C21-	D.19	B1C6-	C.16	B0C23-	B.18	B0C8-	B.08	B0C3-
E.20	B1C22+	D.18	B1C7+	C.17	B0C24+	B.19	B0C9+	B.09	B0C4+
E.19	B1C22-	D.17	B1C7-	C.18	B0C24-	B.20	B0C9-	B.10	B0C4-
E.18	B1C23+	D.16	B1C8+	C.19	B0C25+	B.21	B0C10+	A.01	B0R0+
E.17	B1C23-	D.15	B1C8-	C.20	B0C25-	B.22	B0C10-	A.02	B0R0-
E.16	B1C24+	D.14	B1C9+	C.21	B0C26+	B.23	B0C11+	A.03	B0R1+
E.15	B1C24-	D.13	B1C9-	C.22	B0C26-	B.24	B0C11-	A.04	B0R1-
E.14	B1C25+	D.12	B1C10+	C.23	B0C27+	B.25	B0C12+	A.05	B0R2+
E.13	B1C25-	D.11	B1C10-	C.24	B0C27-	B.26	B0C12-	A.06	B0R2-
E.12	B1C26+	D.10	B1C11+	C.25	B0C28+	B.27	B0C13+	A.07	B0R3+
E.11	B1C26-	D.09	B1C11-	C.26	B0C28-	B.28	B0C13-	A.08	B0R3-
E.10	B1C27+	D.08	B1C12+	C.27	B0C29+	B.29	B0C14+	A.09	B1R0+
E.09	B1C27-	D.07	B1C12-	C.28	B0C29-	B.30	B0C14-	A.10	B1R0-
E.08	B1C28+	D.06	B1C13+	C.29	B0C30+	B.31	B0C15+	A.11	B1R1+
E.07	B1C28-	D.05	B1C13-	C.30	B0C30-	B.32	B0C15-	A.12	B1R1-
E.06	B1C29+	D.04	B1C14+	C.31	B0C31+	C.01	B0C16+	A.13	B1R2+
E.05	B1C29-	D.03	B1C14-	C.32	B0C31-	C.02	B0C16-	A.14	B1R2-
E.04	B1C30+	D.02	B1C15+	D.32	B1C0+	C.03	B0C17+	A.15	B1R3+
E.03	B1C30-	D.01	B1C15-	D.31	B1C0-	C.04	B0C17-	A.16	B1R3-
E.02	B1C31+	E.32	B1C16+	D.30	B1C1+	C.05	B0C18+	Node 2	NC ²
E.01	B1C31-	E.31	B1C16-	D.29	B1C1-	C.06	B0C18-	Node 2	NC ²
Node 1	NC1	E.30	B1C17+	D.28	B1C2+	C.07	B0C19+	Node 2	NC ²
Node 1	NC1	E.29	B1C17-	D.27	B1C2-	C.08	B0C19-	Node 2	NC ²

NC denotes a channel with no connection.

¹ The two Node 1 terminals are connected.

² The four Node 2 terminals are connected.

Table 13. 1-Wire Quad 4 × 32 Configuration (NI TB-2646B)

SCB-264X Name	Channel Name	SCB-264X Name	Channel Name	SCB-264X Name	Channel Name	SCB-264X Name	Channel Name	SCB-264X Name	Channel Name
E.28	B1C18	D.26	B1C3	C.09	B0C20	B.11	B0C5	B.01	B0C0
E.27	B3C18	D.25	B3C3	C.10	B2C20	B.12	B2C5	B.02	B2C0
E.26	B1C19	D.24	B1C4	C.11	B0C21	B.13	B0C6	B.03	B0C1
E.25	B3C19	D.23	B3C4	C.12	B2C21	B.14	B2C6	B.04	B2C1
E.24	B1C20	D.22	B1C5	C.13	B0C22	B.15	B0C7	B.05	B0C2
E.23	B3C20	D.21	B3C5	C.14	B2C22	B.16	B2C7	B.06	B2C2
E.22	B1C21	D.20	B1C6	C.15	B0C23	B.17	B0C8	B.07	B0C3
E.21	B3C21	D.19	B3C6	C.16	B2C23	B.18	B2C8	B.08	B2C3
E.20	B1C22	D.18	B1C7	C.17	B0C24	B.19	B0C9	B.09	B0C4
E.19	B3C22	D.17	B3C7	C.18	B2C24	B.20	B2C9	B.10	B2C4
E.18	B1C23	D.16	B1C8	C.19	B0C25	B.21	B0C10	A.01	B0R0
E.17	B3C23	D.15	B3C8	C.20	B2C25	B.22	B2C10	A.02	B2R0
E.16	B1C24	D.14	B1C9	C.21	B0C26	B.23	B0C11	A.03	B0R1
E.15	B3C24	D.13	B3C9	C.22	B2C26	B.24	B2C11	A.04	B2R1
E.14	B1C25	D.12	B1C10	C.23	B0C27	B.25	B0C12	A.05	B0R2
E.13	B3C25	D.11	B3C10	C.24	B2C27	B.26	B2C12	A.06	B2R2
E.12	B1C26	D.10	B1C11	C.25	B0C28	B.27	B0C13	A.07	B0R3
E.11	B3C26	D.09	B3C11	C.26	B2C28	B.28	B2C13	A.08	B2R3
E.10	B1C27	D.08	B1C12	C.27	B0C29	B.29	B0C14	A.09	B1R0
E.09	B3C27	D.07	B3C12	C.28	B2C29	B.30	B2C14	A.10	B3R0
E.08	B1C28	D.06	B1C13	C.29	B0C30	B.31	B0C15	A.11	B1R1
E.07	B3C28	D.05	B3C13	C.30	B2C30	B.32	B2C15	A.12	B3R1
E.06	B1C29	D.04	B1C14	C.31	B0C31	C.01	B0C16	A.13	B1R2
E.05	B3C29	D.03	B3C14	C.32	B2C31	C.02	B2C16	A.14	B3R2
E.04	B1C30	D.02	B1C15	D.32	B1C0	C.03	B0C17	A.15	B1R3
E.03	B3C30	D.01	B3C15	D.31	B3C0	C.04	B2C17	A.16	B3R3
E.02	B1C31	E.32	B1C16	D.30	B1C1	C.05	B0C18	Node 2	NC ²
E.01	B3C31	E.31	B3C16	D.29	B3C1	C.06	B2C18	Node 2	NC ²
Node 1	NC1	E.30	B1C17	D.28	B1C2	C.07	B0C19	Node 2	NC ²
Node 1	NC1	E.29	B3C17	D.27	B3C2	C.08	B2C19	Node 2	NC ²

NC denotes a channel with no connection.

¹ The two Node 1 terminals are connected.

² The four Node 2 terminals are connected.

6. Connect the Terminal Block to the Switch Module

To connect the terminal block to the switch module, refer to the appropriate installation instructions for your NI TB-264X/264XB.

Figure 3 illustrates the NI SCB-264X connected to the NI PXI/PXIe-2532 through the NI TB-2640. The NI TB-264X connects with the NI PXI/PXIe-2532 only.

Figure 4 illustrates the NI SCB-264X connected to the NI PXI-2532B through the NI TB-2640B. The NI TB-264XB connects with the NI PXI/PXIe-2532B only.



Note The number of ribbon cables required and the cable connections will differ for each NI TB-264X/264XB.

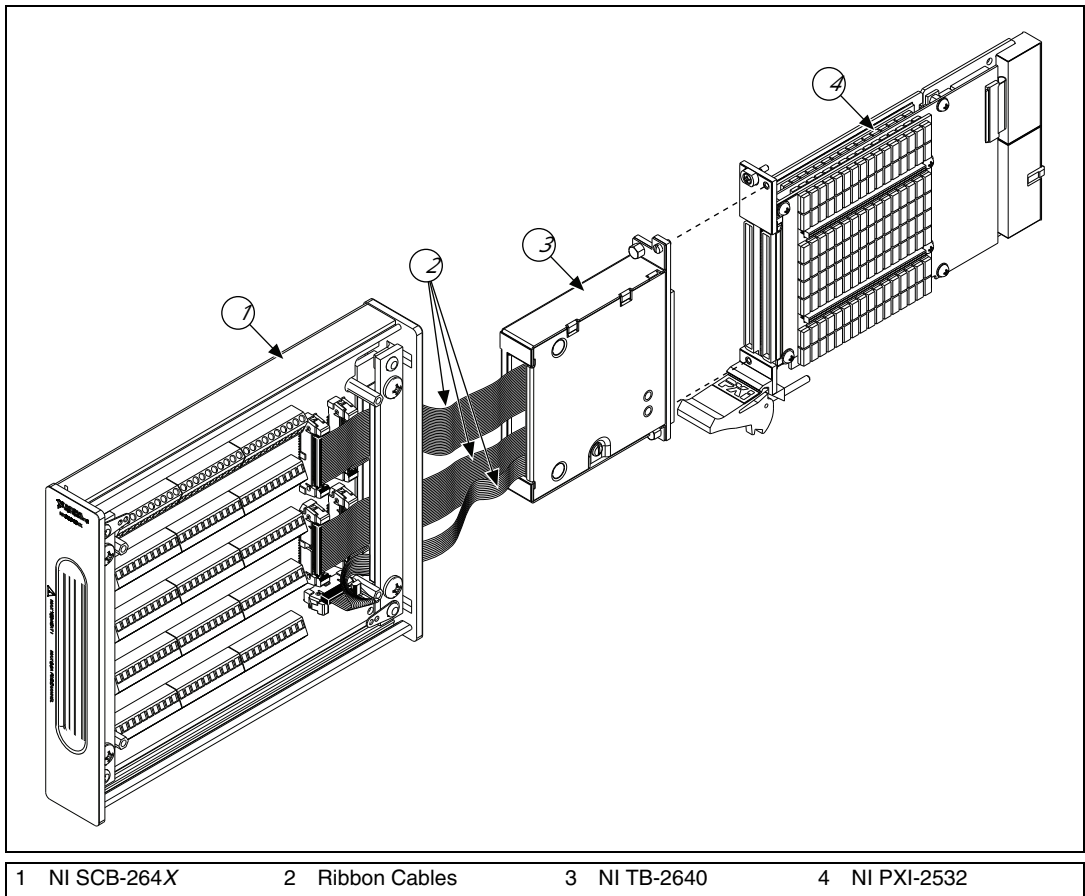

Figure 3. NI SCB-264X Connections Using the NI TB-2640

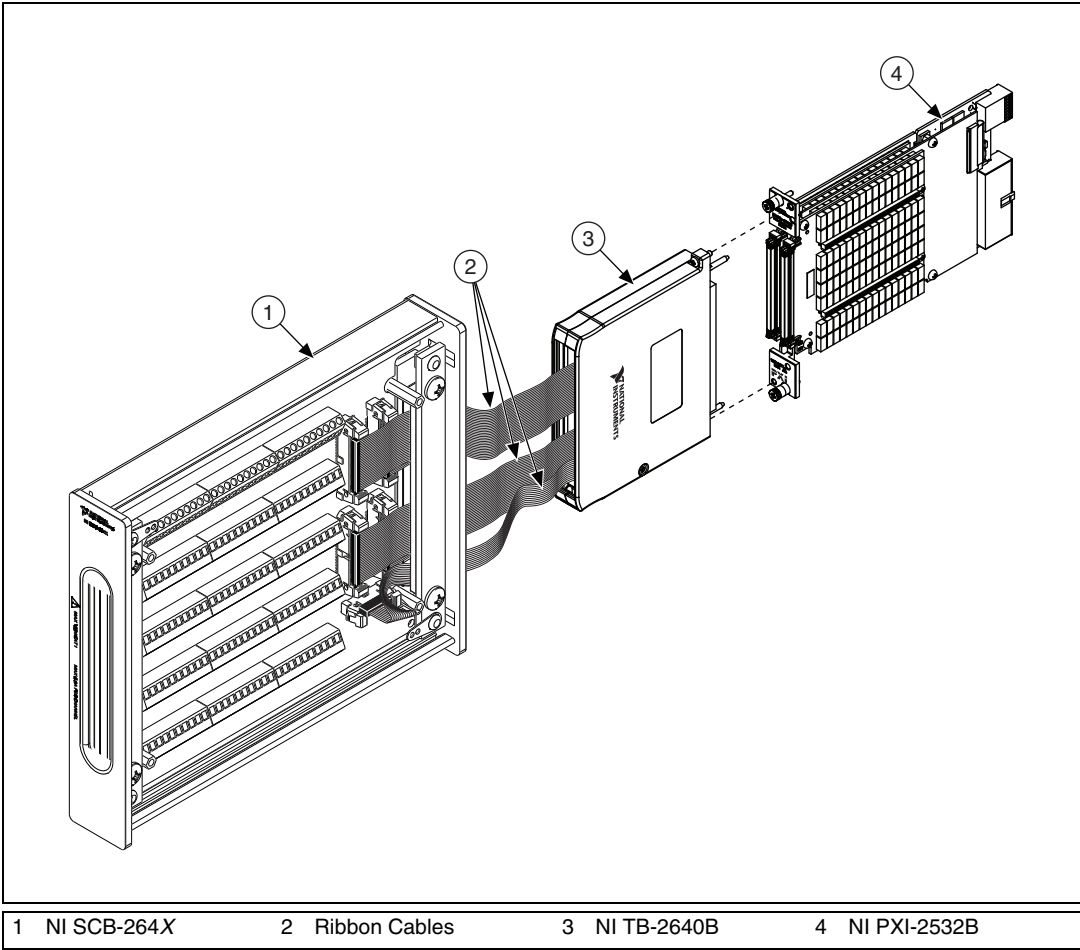

Figure 4. NI SCB-264X Connections Using the NI TB-2640B

Specifications

This section lists additional specifications for the NI SCB-264X used with the NI PXI/PXIe-2532/2532B. All specifications are subject to change without notice. Visit ni.com/manuals for the most current specifications.

Input Characteristics

All NI SCB 264X input characteristics are DC unless otherwise specified.

Maximum switching voltage

Channel-to-channel 60 VDC

Channel-to-ground 60 VDC, CAT I



Caution When the NI SCB-264X is used with NI 2532/2532B, the maximum switching voltage of the NI 2532/2532B must be limited to 60 VDC.

Maximum current (per channel) 0.5 A

DC path resistance $<3.0 \Omega$ + cable resistance

Physical Characteristics

Maximum wire gauge 16 AWG

Weight 976 g

Compliance and Certifications

Safety

This product meets the requirements of the following standards of safety for electrical equipment for measurement, control, and laboratory use:

- IEC 61010-1, EN 61010-1
- UL 61010-1, CSA 61010-1



Note For UL and other safety certifications, refer to the product label or the [Online Product Certification](#) section.



Note The SCB-264X is for indoor use only.

Electromagnetic Compatibility

This product meets the requirements of the following EMC standards for electrical equipment for measurement, control, and laboratory use:

- EN 61326-1 (IEC 61326-1): Class A emissions; Basic immunity
- EN 55011 (CISPR 11): Group 1, Class A emissions
- AS/NZS CISPR 11: Group 1, Class A emissions
- FCC 47 CFR Part 15B: Class A emissions
- ICES-001: Class A emissions



Note In the United States (per FCC 47 CFR), Class A equipment is intended for use in commercial, light-industrial, and heavy-industrial locations. In Europe, Canada, Australia and New Zealand (per CISPR 11) Class A equipment is intended for use only in heavy-industrial locations.



Note Group 1 equipment (per CISPR 11) is any industrial, scientific, or medical equipment that does not intentionally generate radio frequency energy for the treatment of material or inspection/analysis purposes.



Note For EMC declarations and certifications, and additional information, refer to the *Online Product Certification* section.

CE Compliance

This product meets the essential requirements of applicable European Directives as follows:

- 2006/95/EC; Low-Voltage Directive (safety)
- 2004/108/EC; Electromagnetic Compatibility Directive (EMC)

Online Product Certification

To obtain product certifications and the Declaration of Conformity (DoC) for this product, visit ni.com/certification, search by model number or product line, and click the appropriate link in the Certification column.

Environmental Management

NI is committed to designing and manufacturing products in an environmentally responsible manner. NI recognizes that eliminating certain hazardous substances from our products is beneficial to the environment and to NI customers.

For additional environmental information, refer to the *Minimize Our Environmental Impact* web page at ni.com/environment. This page contains the environmental regulations and directives with which NI complies, as well as other environmental information not included in this document

Waste Electrical and Electronic Equipment (WEEE)



EU Customers At the end of the product life cycle, all products *must* be sent to a WEEE recycling center. For more information about WEEE recycling centers, National Instruments WEEE initiatives, and compliance with WEEE Directive 2002/96/EC on Waste Electrical and Electronic Equipment, visit ni.com/environment/weee.

电子信息产品污染控制管理办法（中国 RoHS）



中国客户 National Instruments 符合中国电子信息产品中限制使用某些有害物质指令 (RoHS)。关于 National Instruments 中国 RoHS 合规性信息, 请登录 ni.com/environment/rohs_china。(For information about China RoHS compliance, go to ni.com/environment/rohs_china.)

LabVIEW, National Instruments, NI, ni.com, the National Instruments corporate logo, and the Eagle logo are trademarks of National Instruments Corporation. Refer to the *Trademark Information* at ni.com/trademarks for other National Instruments trademarks. Other product and company names mentioned herein are trademarks or trade names of their respective companies. For patents covering National Instruments products/technology, refer to the appropriate location: **Help»Patents** in your software, the `patents.txt` file on your media, or the *National Instruments Patent Notice* at ni.com/patents. You can find information about end-user license agreements (EULAs) and third-party legal notices in the NI-SWITCH Readme. Refer to the *Export Compliance Information* at ni.com/legal/export-compliance for the National Instruments global trade compliance policy and how to obtain relevant HTS codes, ECCNs, and other import/export data.