

COMPREHENSIVE SERVICES

We offer competitive repair and calibration services, as well as easily accessible documentation and free downloadable resources.

SELL YOUR SURPLUS

We buy new, used, decommissioned, and surplus parts from every NI series. We work out the best solution to suit your individual needs.

 Sell For Cash  Get Credit  Receive a Trade-In Deal

OBSOLETE NI HARDWARE IN STOCK & READY TO SHIP

We stock **New**, **New Surplus**, **Refurbished**, and **Reconditioned** NI Hardware.



Bridging the gap between the manufacturer and your legacy test system.

 1-800-915-6216

 www.apexwaves.com

 sales@apexwaves.com

All trademarks, brands, and brand names are the property of their respective owners.

Request a Quote

 **CLICK HERE**

TBX-1316

INSTALLATION GUIDE

TBX-1316 High-Voltage Attenuator Terminal Block

This guide describes how to install and use the TBX-1316 high-voltage attenuator terminal block with the following modules:

- SCXI-1125 (recommended)
- SCXI-1126
- SCXI-1120/D

The TBX-1316 is a shielded metal enclosure with a built-in high-voltage attenuator. You can use it to measure high-voltage signals of up to 1000 V Category I and 600 V Category II.



Caution Do *not* use the TBX-1316 to connect to signals above 600 V Category II. Do *not* use the TBX-1316 in Category III or IV applications. Do *not* connect to MAINS supply circuits above 600 VAC.

The TBX-1316 has eight differential high-voltage input channels. Each high-voltage input channel has three screw terminals—one each for input plus, input minus, and chassis ground. For maximum safety, all the chassis-ground terminals and the enclosure are connected. You can use 6 to 20 AWG signal wire in the screw terminals. Use an SH3232 shielded cable to connect the TBX-1316 to the module.



Note Refer to the *Read Me First: Safety and Radio-Interference* document for definitions of Categories and other safety information.



Caution Do *not* use uninsulated input signal wires. All input signal wires *must* be separated from each other and *must* have a minimum voltage rating of 1000 V for Category I or 600 V for Category II and have a temperature rating of 90 °C.

Each input channel is formed by a pair of 200:1 fixed-attenuation-ratio high-voltage resistor networks. The nominal inaccuracy of the attenuation factor is < 1%, and the attenuation-ratio drift temperature coefficient is < 20 ppm/°C.



Caution Install an application appropriate UL-Listed external breaker (disconnect) for each input line.

A calibration EEPROM is built into the TBX-1316. When the TBX-1316 is used in conjunction with an SCXI-1125, the EEPROM stores calibration constants. These constants provide software correction values that the application development software uses to correct measurements for gain error in the attenuation circuitry. The EEPROM is shipped with nominal values. Refer to the *Calibrating the TBX-1316* section for calibration information.

Conventions

The following conventions are used in this guide:

»

The » symbol leads you through nested menu items and dialog box options to a final action. The sequence **File»Page Setup»Options** directs you to pull down the **File** menu, select the **Page Setup** item, and select **Options** from the last dialog box.



This icon denotes a note, which alerts you to important information.



This icon denotes a caution, which advises you of precautions to take to avoid injury, data loss, or a system crash. When this icon is marked on the product, refer to the *Read Me First: Safety and Radio-Frequency Interference* document, shipped with the product, for precautions to take.



When symbol is marked on a product it denotes a warning advising you to take precautions to avoid electrical shock.



When symbol is marked on a product it denotes a component that may be hot. Touching this component may result in bodily injury.

bold

Bold text denotes items that you must select or click in the software, such as menu items and dialog box options. Bold text also denotes parameter names.

italic

Italic text denotes variables, emphasis, a cross reference, or an introduction to a key concept. This font also denotes text that is a placeholder for a word or value that you must supply.

monospace

Text in this font denotes text or characters that you should enter from the keyboard, sections of code, programming examples, and syntax examples. This font is also used for the proper names of disk drives, paths, directories, programs, subprograms, subroutines, device names, functions, operations, variables, filenames, and extensions.

What You Need to Get Started

To install and use the TBX-1316, you need the following items:

Hardware

- TBX-1316 terminal block
- One of the following modules:
 - SCXI-1125 (recommended)
 - SCXI-1126
 - SCXI-1120/D
- One of the following chassis:
 - SCXI
 - PXI/SCXI combination
- One of the following:
 - E/M Series DAQ PCI device
 - E/M Series DAQ PXI module
- SH3232 shielded cable and cable adapter as required for your application

Documentation

- *Read Me First: Safety and Radio-Frequency Interference*
- *DAQ Quick Start Guide*
- *SCXI Quick Start Guide*
- *TBX-1316 High-Voltage Attenuator Terminal Block Installation Guide*
- One of the following user manuals (application-dependent):
 - *SCXI-1125 User Manual*
 - *SCXI-1126 User Manual*
 - *SCXI-1120/D User Manual*
- SCXI or PXI/SCXI combination chassis user manual

Tools

- Number 1 and 2 Phillips screwdriver
- 1/8 and 3/8 in. flathead screwdriver
- Long nose pliers
- Wire cutter

- Wire insulation stripper
- Miscellaneous tools to permanently mount the enclosure

Installing the TBX-1316 Enclosure



Note Refer to the *Read Me First: Safety and Radio-Frequency Interference* document before removing equipment covers or connecting or disconnecting any signal wires.

To install the TBX-1316 enclosure, complete the following steps:

1. Install an application appropriate UL-Listed external breaker (disconnect) for each input line as follows:
 - a. Install the disconnect device(s) within close proximity of the TBX-1316 and within easy reach of the operator.
 - b. Mark this enclosure as a disconnect device.



Note The TBX-1316 is intended for mounting in a permanent location. NI recommends installing the enclosure in a permanent location whenever possible.

2. Securely mount the enclosure to the building per the local safety codes. If the enclosure is mounted on plaster board (drywall), mount the enclosure using four #14 × 1 1/2 in. wood screws installed through the four, 7.6 mm (0.3 in.) clearance mounting holes. Position the enclosure so that all four screws are driven into wooden studs. Figure 1 shows the clearance holes.
3. While referring to Figure 2, unlock and open the enclosure door using a 3/8 in. flathead screwdriver.
4. While referring to Figure 3, complete the following steps to install the protective earth (PE) ground wire.



Note The PE ground wire *must* comply with your local codes and be the same or larger size AWG as the input signal wires.

- a. Insert the PE ground wire through the PE ground strain-relief collar.
- b. Install a UL-Listed uninsulated closed-ring terminal, suitable to your application, on the end of the PE ground wire.
- c. Place the lock-washer over the ground-screw followed by the PE ground terminal.
- d. Place the provided lock washer over the end of the ground screw. The screw should now have a ring terminal between two lock washers.

- e. Install the ground-screw/lock-washer into the enclosure, and tighten it with a number 2 Phillips screwdriver.
- f. Tighten the PE ground strain-relief collar.

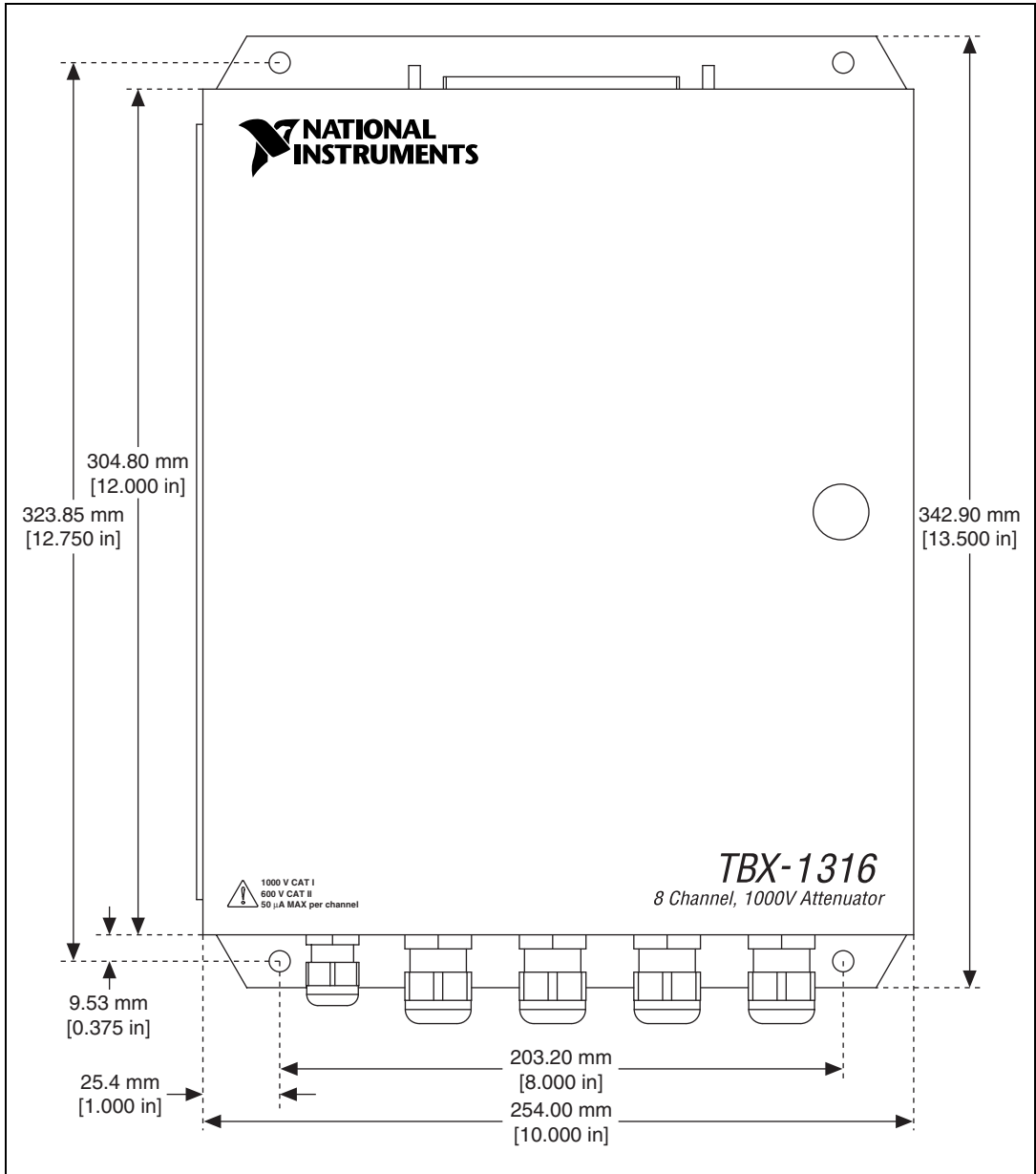

Figure 1. TBX-1316 Enclosure Mounting Hole Spacing

Connecting the Signals



Note Be certain that the signal wires are of the appropriate AWG and voltage for your application, and are rated for 90 °C.

To connect a signal to the TBX-1316, perform the following steps while referring to Figures 2 and 3:

1. Unlock and open the enclosure door using a 3/8 in. flathead screwdriver.

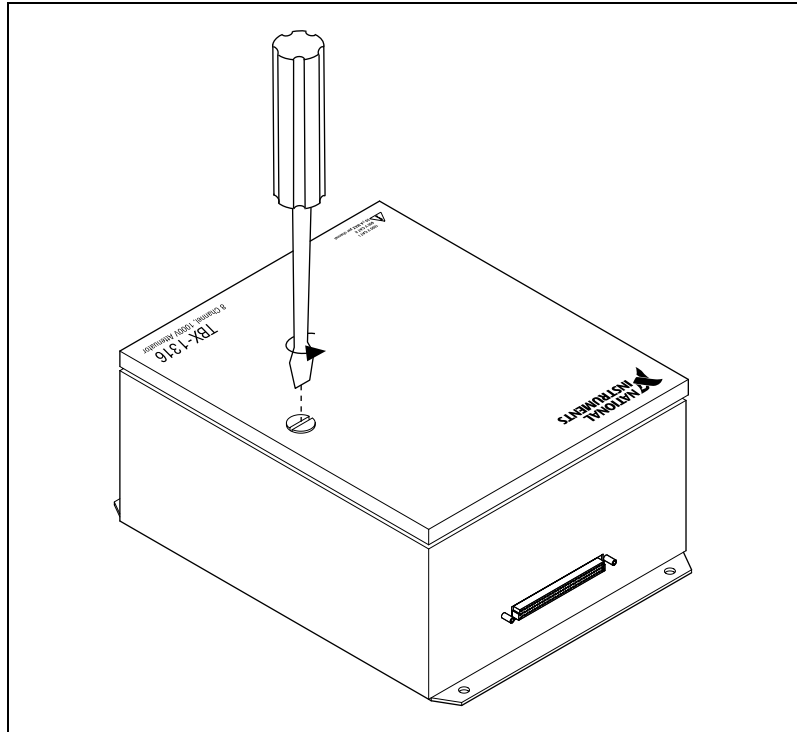

Figure 2. Opening the TBX-1316

2. Loosen the signal strain-relief collar.
3. Run the signal wires through the strain-relief opening.
4. Prepare the signal wire by stripping the insulation no more than 10 mm (0.39 in.).



Note When connecting the signals to the TBX-1316, follow the labeling on the TBX-1316.

5. Connect chassis ground to the chassis-ground terminal strip.
6. Connect the signal wires to the signal wire screw terminals by inserting the stripped end of the wire fully into the terminal.



Caution No bare wire should extend past the screw terminal. Exposed wire increases the risk of short circuits and failures.

7. Tighten the terminal screws to a torque of 1.2 to 1.5 N · m (10.62 to 13.28 in. · lb).
8. Tighten the signal strain-relief collar.
9. Repeat steps 2 through 8 for each signal wire.
10. Close and lock the enclosure door.
11. Connect the TBX-1316 to the SCXI module front connector as explained in the [Connecting the Module](#) section.

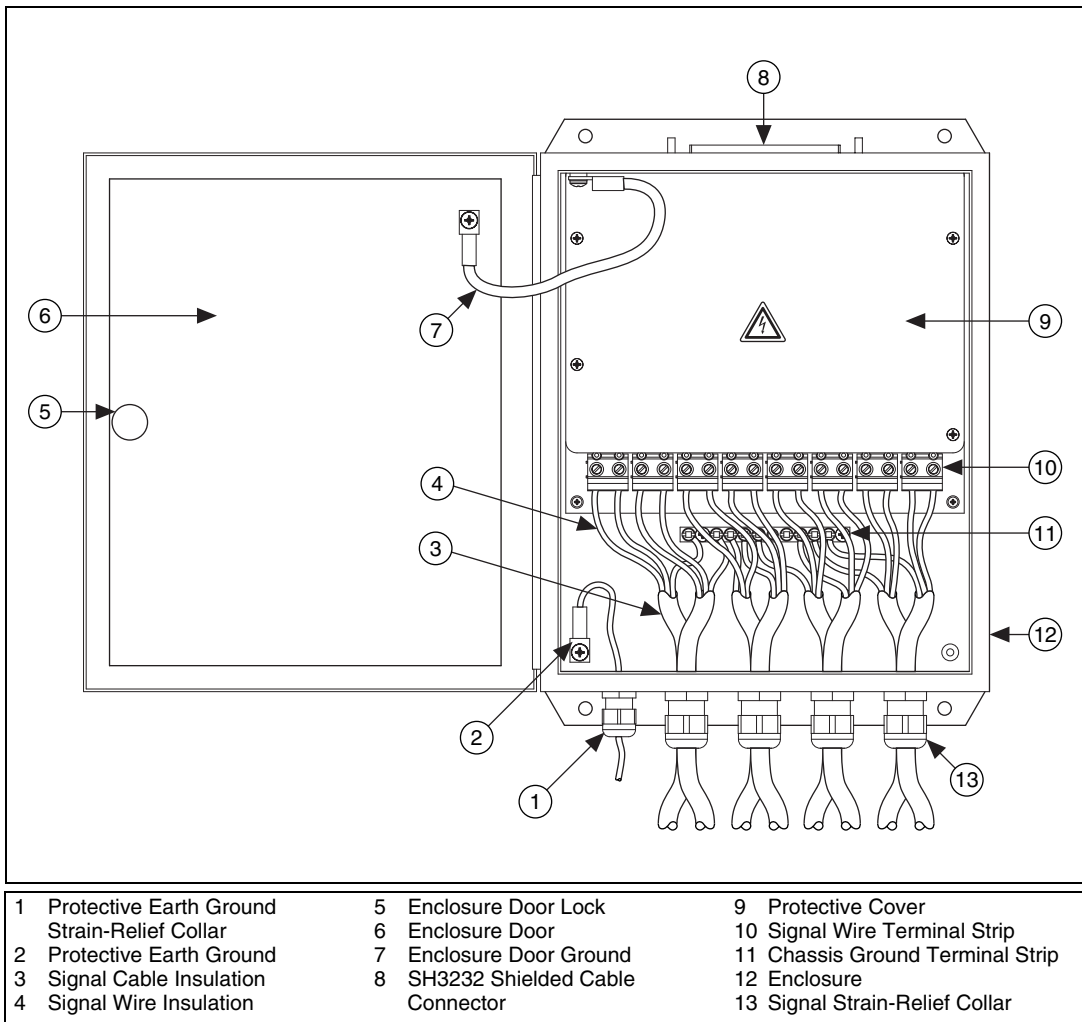

Figure 3. TBX-1316 Parts Locator Diagram

Connecting the Module

This section describes how to connect the TBX-1316 to an SCXI and PXI/SCXI combination chassis.



Note The illustrations show the SCXI chassis only.

To connect the TBX-1316 to an SCXI module front connector, perform the following steps:

1. If you have not already installed the E/M Series DAQ device, refer to the *DAQ Quick Start Guide* for installation instructions.
2. If you have not already installed the SCXI module, refer to the *SCXI Quick Start Guide* for installation instructions.
3. Power off the SCXI chassis.
4. Do one of the following:
 - Power off the computer that contains the E/M Series DAQ device, and disconnect the device from the chassis.
 - Power off the PXI portion of the PXI/SCXI combination chassis, and if used, remove the cable connecting the SCXI portion of the chassis to E/M Series device.
5. Connect the TBX cable adapter to the appropriate SCXI module, and secure it by tightening both thumbscrews, as shown in Figure 4.

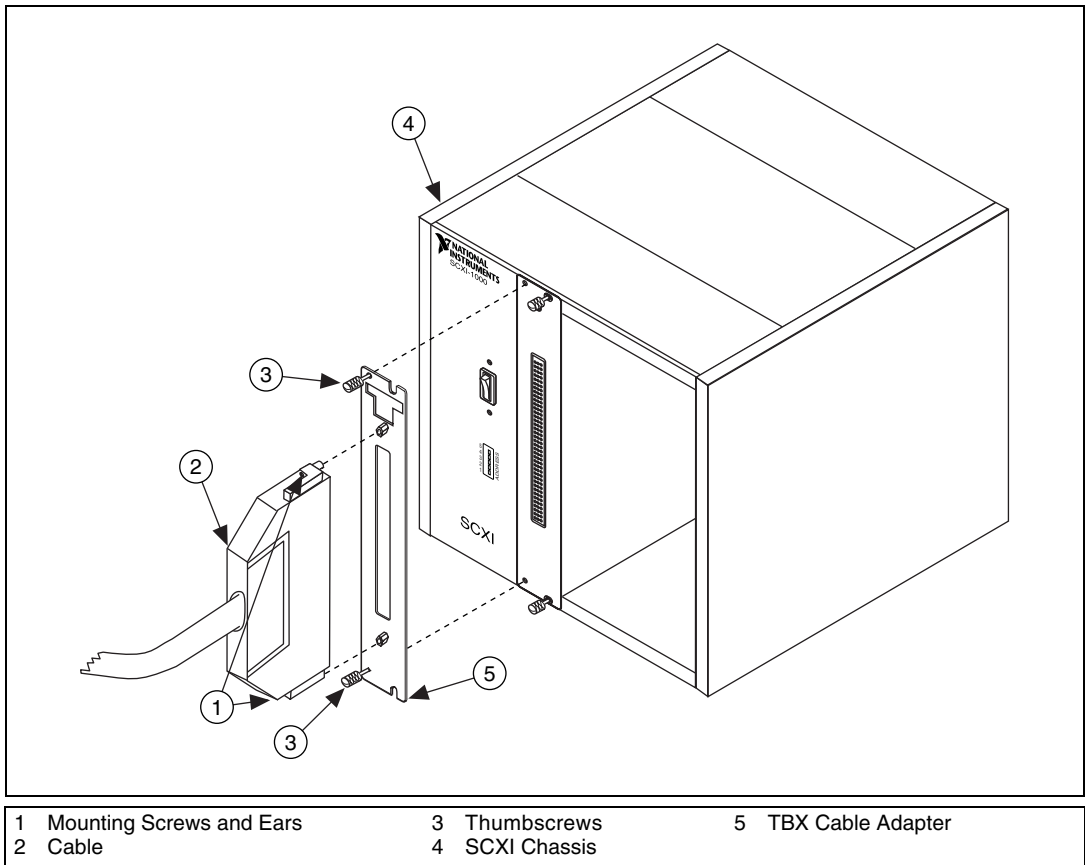

Figure 4. Connecting the Cable to the SCXI Module

6. Connect one end of the cable assembly to the SH3232 shielded cable connector on the TBX-1316, and secure the cable by tightening both mounting screws, as shown in Figure 5.

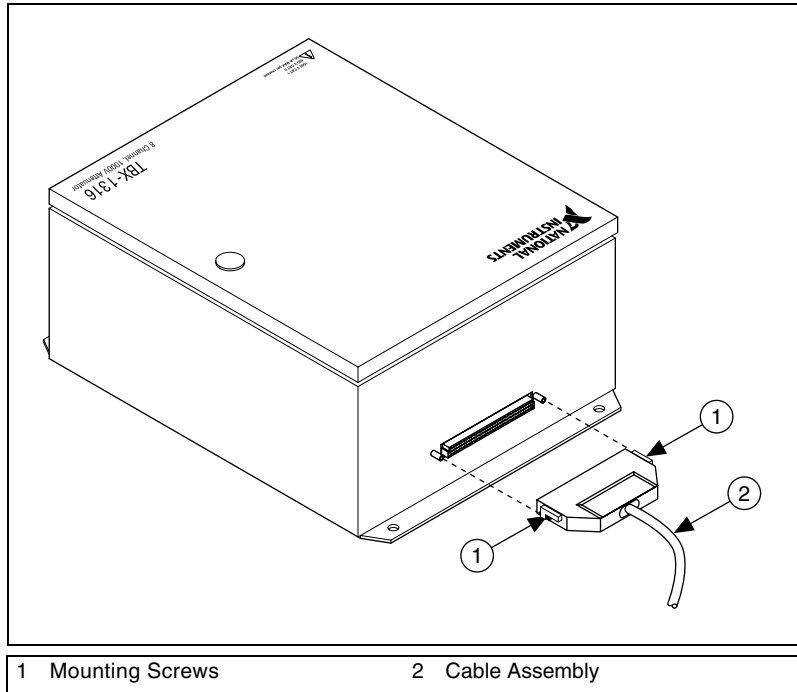

Figure 5. Connecting the Cable to the TBX-1316

7. Connect the other end of the cable assembly to the SCXI module front connector, and secure the cable by tightening the mounting screws. Figure 6 shows the completed installation.

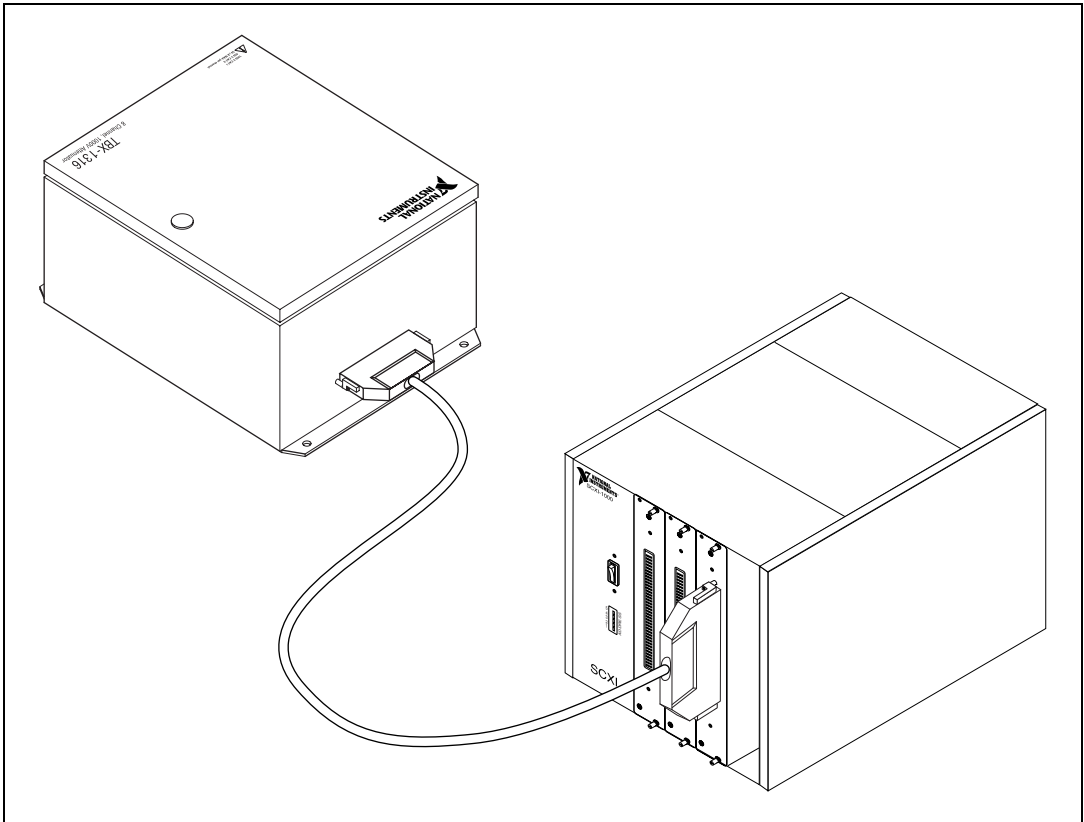

Figure 6. Completed Installation

8. If necessary, reconnect the E/M Series DAQ device to the chassis.
9. Refer to the *SCXI Quick Start Guide* to power on the SCXI chassis and configure the system in software.

Calibrating the TBX-1316

NI recommends you perform an external calibration once a year. You can download all available external calibration documents from ni.com/calibration by clicking **Manual Calibration Procedures**.

Specifications

All specifications are typical at 25 °C unless otherwise specified.

Input Voltage Range

AC/DC	1000 V Category I
AC/DC	600 V Category II
Max input current per channel.....	50 μ A
Impulse overvoltage	4000 V
Bandwidth (3 dB)	
SCXI-1125.....	400 Hz
SCXI-1120.....	400 Hz
Attenuation ratio	200:1 (fixed)
Attenuation-ratio accuracy	
Uncalibrated	1% max
Attenuation-ratio temperature drift.....	20 ppm/°C max
Differential input resistance.....	44 M Ω typ

Physical

NI recommends that the TBX-1316 be permanently connected equipment with an appropriate UL Listed external breaker for each line.

Enclosure protective earth (PE) ground *must* be installed.

Dimensions	30.48 \times 25.40 \times 15.24 cm (12 \times 10 \times 6 in.)
Weight	5.8 kg (12.8 lb)
Strain-relief cable diameter.....	6 to 12 mm signals (0.24 to 0.47 in.) 4 to 8 mm PE ground (0.157 to 0.314 in.)



Note If your application cable diameter is smaller than what is listed above, replace the supplied strain reliefs with the following strain reliefs or their equivalents. These strain reliefs are not supplied with the TBX-1316.

Strain-relief cable diameter	5 to 9 mm signals (0.197 to 0.354 in.) SKINTOP # S2213 2 to 6 mm PE ground (0.079 to 0.236 in.) SKINTOP # S2209
Strain reliefs available	8 signals 1 PE ground
Field wire	
Diameter	6 to 20 AWG
Temperature rating	90 °C
Connector type	Screw terminal

Environmental

Operating temperature	0 to 55 °C
Storage temperature	-20 to 70 °C
Humidity	10 to 90% RH, noncondensing
Maximum altitude	2,000 m
Pollution Degree (indoor use only)	2

Safety

The TBX-1316 is designed to meet the requirements of the following standards of safety for electrical equipment for measurement, control, and laboratory use:

- IEC 61010-1, EN 61010-1
- UL 61010-1
- CAN/CSA-C22.2 No. 61010-1



Note For UL and other safety certifications, refer to the product label, or visit ni.com/certification, search by model number or product line, and click the appropriate link in the Certification column.

Electromagnetic Compatibility

Emissions	EN 55011 Class A at 10 m FCC Part 15A above 1 GHz
Immunity	EN 61326:1997 + A2:2001, Table 1
EMC/EMI	CE, C-Tick, and FCC Part 15 (Class A) Compliant



Note For EMC compliance, operate this device with shielded cabling.

CE Compliance

The TBX-1316 meets the essential requirements of applicable European Directives, as amended for CE marking, as follows:

Low-Voltage Directive (safety).....73/23/EEC

Electromagnetic Compatibility
Directive (EMC).....89/336/EEC



Note Refer to the Declaration of Conformity (DoC) for this product for any additional regulatory compliance information. To obtain the DoC for this product, visit ni.com/certification, search by model number or product line, and click the appropriate link in the Certification column.

National Instruments, NI, ni.com, and LabVIEW are trademarks of National Instruments Corporation. Refer to the *Terms of Use* section on ni.com/legal for more information about National Instruments trademarks. Other product and company names mentioned herein are trademarks or trade names of their respective companies. For patents covering National Instruments products, refer to the appropriate location: **Help»Patents** in your software, the `patents.txt` file on your CD, or ni.com/patents.