

COMPREHENSIVE SERVICES

We offer competitive repair and calibration services, as well as easily accessible documentation and free downloadable resources.

SELL YOUR SURPLUS

We buy new, used, decommissioned, and surplus parts from every NI series. We work out the best solution to suit your individual needs.

 Sell For Cash  Get Credit  Receive a Trade-In Deal

OBSOLETE NI HARDWARE IN STOCK & READY TO SHIP

We stock **New**, **New Surplus**, **Refurbished**, and **Reconditioned** NI Hardware.



Bridging the gap between the manufacturer and your legacy test system.

 1-800-915-6216

 www.apexwaves.com

 sales@apexwaves.com

All trademarks, brands, and brand names are the property of their respective owners.

Request a Quote

 **CLICK HERE**

TBX-68

DAQ Analog Output Series

Analog Output Series User Manual

*NI 6711/6713/DAQCard-6715, NI 6722/6723, and NI 6731/6733
Devices*

Worldwide Technical Support and Product Information

ni.com

Worldwide Offices

Visit ni.com/niglobal to access the branch office websites, which provide up-to-date contact information, support phone numbers, email addresses, and current events.

National Instruments Corporate Headquarters

11500 North Mopac Expressway Austin, Texas 78759-3504 USA Tel: 512 683 0100

For further support information, refer to the *NI Services* appendix. To comment on NI documentation, refer to the NI website at ni.com/info and enter the Info Code `feedback`.

© 2003–2017 National Instruments. All rights reserved.

Legal Information

Limited Warranty

This document is provided 'as is' and is subject to being changed, without notice, in future editions. For the latest version, refer to ni.com/manuals. NI reviews this document carefully for technical accuracy; however, NI MAKES NO EXPRESS OR IMPLIED WARRANTIES AS TO THE ACCURACY OF THE INFORMATION CONTAINED HEREIN AND SHALL NOT BE LIABLE FOR ANY ERRORS.

NI warrants that its hardware products will be free of defects in materials and workmanship that cause the product to fail to substantially conform to the applicable NI published specifications for one (1) year from the date of invoice.

For a period of ninety (90) days from the date of invoice, NI warrants that (i) its software products will perform substantially in accordance with the applicable documentation provided with the software and (ii) the software media will be free from defects in materials and workmanship.

If NI receives notice of a defect or non-conformance during the applicable warranty period, NI will, in its discretion: (i) repair or replace the affected product, or (ii) refund the fees paid for the affected product. Repaired or replaced Hardware will be warranted for the remainder of the original warranty period or ninety (90) days, whichever is longer. If NI elects to repair or replace the product, NI may use new or refurbished parts or products that are equivalent to new in performance and reliability and are at least functionally equivalent to the original part or product.

You must obtain an RMA number from NI before returning any product to NI. NI reserves the right to charge a fee for examining and testing Hardware not covered by the Limited Warranty.

This Limited Warranty does not apply if the defect of the product resulted from improper or inadequate maintenance, installation, repair, or calibration (performed by a party other than NI); unauthorized modification; improper environment; use of an improper hardware or software key; improper use or operation outside of the specification for the product; improper voltages; accident, abuse, or neglect; or a hazard such as lightning, flood, or other act of nature.

THE REMEDIES SET FORTH ABOVE ARE EXCLUSIVE AND THE CUSTOMER'S SOLE REMEDIES, AND SHALL APPLY EVEN IF SUCH REMEDIES FAIL OF THEIR ESSENTIAL PURPOSE.

EXCEPT AS EXPRESSLY SET FORTH HEREIN, PRODUCTS ARE PROVIDED "AS IS" WITHOUT WARRANTY OF ANY KIND AND NI DISCLAIMS ALL WARRANTIES, EXPRESSED OR IMPLIED, WITH RESPECT TO THE PRODUCTS, INCLUDING ANY IMPLIED WARRANTIES OF MERCHANTABILITY, FITNESS FOR A PARTICULAR PURPOSE, TITLE OR NON-INFRINGEMENT, AND ANY WARRANTIES THAT MAY ARISE FROM USAGE OF TRADE OR COURSE OF DEALING. NI DOES NOT WARRANT, GUARANTEE, OR MAKE ANY REPRESENTATIONS REGARDING THE USE OF OR THE RESULTS OF THE USE OF THE PRODUCTS IN TERMS OF CORRECTNESS, ACCURACY, RELIABILITY, OR OTHERWISE. NI DOES NOT WARRANT THAT THE OPERATION OF THE PRODUCTS WILL BE UNINTERRUPTED OR ERROR FREE.

In the event that you and NI have a separate signed written agreement with warranty terms covering the products, then the warranty terms in the separate agreement shall control.

Copyright

Under the copyright laws, this publication may not be reproduced or transmitted in any form, electronic or mechanical, including photocopying, recording, storing in an information retrieval system, or translating, in whole or in part, without the prior written consent of National Instruments Corporation.

National Instruments respects the intellectual property of others, and we ask our users to do the same. NI software is protected by copyright and other intellectual property laws. Where NI software may be used to reproduce software or other materials belonging to others, you may use NI software only to reproduce materials that you may reproduce in accordance with the terms of any applicable license or other legal restriction.

End-User License Agreements and Third-Party Legal Notices

You can find end-user license agreements (EULAs) and third-party legal notices in the following locations:

- Notices are located in the <National Instruments>_Legal Information and <National Instruments> directories.
- EULAs are located in the <National Instruments>\Shared\MDF\Legal\license directory.
- Review <National Instruments>_Legal Information.txt for information on including legal information in installers built with NI products.

U.S. Government Restricted Rights

If you are an agency, department, or other entity of the United States Government ("Government"), the use, duplication, reproduction, release, modification, disclosure or transfer of the technical data included in this manual is governed by the Restricted Rights provisions under Federal Acquisition Regulation 52.227-14 for civilian agencies and Defense Federal Acquisition Regulation Supplement Section 252.227-7014 and 252.227-7015 for military agencies.

Trademarks

Refer to the *NI Trademarks and Logo Guidelines* at ni.com/trademarks for more information on NI trademarks.

ARM, Keil, and μ Vision are trademarks or registered of ARM Ltd or its subsidiaries.

LEGO, the LEGO logo, WEDO, and MINDSTORMS are trademarks of the LEGO Group.

TETRIX by Pitsco is a trademark of Pitsco, Inc.

FIELDBUS FOUNDATION™ and FOUNDATION™ are trademarks of the Fieldbus Foundation.

EtherCAT® is a registered trademark of and licensed by Beckhoff Automation GmbH.

CANopen® is a registered Community Trademark of CAN in Automation e.V.

DeviceNet™ and EtherNet/IP™ are trademarks of ODVA.

Go!, SensorDAQ, and Vernier are registered trademarks of Vernier Software & Technology. Vernier Software & Technology and vernier.com are trademarks or trade dress.

Xilinx is the registered trademark of Xilinx, Inc.

Taptite and Trilobular are registered trademarks of Research Engineering & Manufacturing Inc.

FireWire® is the registered trademark of Apple Inc.

Linux® is the registered trademark of Linus Torvalds in the U.S. and other countries.

Handle Graphics®, MATLAB®, Simulink®, Stateflow®, and xPC TargetBox® are registered trademarks, and Simulink Coder™, TargetBox™, and Target Language Compiler™ are trademarks of The MathWorks, Inc.

Tektronix®, Tek, and Tektronix, Enabling Technology are registered trademarks of Tektronix, Inc.

The Bluetooth® word mark is a registered trademark owned by the Bluetooth SIG, Inc.

The ExpressCard™ word mark and logos are owned by PCMCIA and any use of such marks by National Instruments is under license.

The mark LabWindows is used under a license from Microsoft Corporation. Windows is a registered trademark of Microsoft Corporation in the United States and other countries.

Other product and company names mentioned herein are trademarks or trade names of their respective companies.

Members of the National Instruments Alliance Partner Program are business entities independent from NI and have no agency, partnership, or joint-venture relationship with NI.

Patents

For patents covering NI products/technology, refer to the appropriate location: **Help»Patents** in your software, the `patents.txt` file on your media, or the *National Instruments Patent Notice* at ni.com/patents.

Export Compliance Information

Refer to the *Export Compliance Information* at ni.com/legal/export-compliance for the NI global trade compliance policy and how to obtain relevant HTS codes, ECCNs, and other import/export data.

WARNING REGARDING USE OF NATIONAL INSTRUMENTS PRODUCTS

YOU ARE ULTIMATELY RESPONSIBLE FOR VERIFYING AND VALIDATING THE SUITABILITY AND RELIABILITY OF THE PRODUCTS WHENEVER THE PRODUCTS ARE INCORPORATED IN YOUR SYSTEM OR APPLICATION, INCLUDING THE APPROPRIATE DESIGN, PROCESS, AND SAFETY LEVEL OF SUCH SYSTEM OR APPLICATION.

PRODUCTS ARE NOT DESIGNED, MANUFACTURED, OR TESTED FOR USE IN LIFE OR SAFETY CRITICAL SYSTEMS, HAZARDOUS ENVIRONMENTS OR ANY OTHER ENVIRONMENTS REQUIRING FAIL-SAFE PERFORMANCE, INCLUDING IN THE OPERATION OF NUCLEAR FACILITIES; AIRCRAFT NAVIGATION; AIR TRAFFIC CONTROL SYSTEMS; LIFE SAVING OR LIFE SUSTAINING SYSTEMS OR SUCH OTHER MEDICAL DEVICES; OR ANY OTHER APPLICATION IN WHICH THE FAILURE OF THE PRODUCT OR SERVICE COULD LEAD TO DEATH, PERSONAL INJURY, SEVERE PROPERTY DAMAGE OR ENVIRONMENTAL HARM (COLLECTIVELY, "HIGH-RISK USES"). FURTHER, PRUDENT STEPS MUST BE TAKEN TO PROTECT AGAINST FAILURES, INCLUDING PROVIDING BACK-UP AND SHUT-DOWN MECHANISMS. NI EXPRESSLY DISCLAIMS ANY EXPRESS OR IMPLIED WARRANTY OF FITNESS OF THE PRODUCTS OR SERVICES FOR HIGH-RISK USES.

Compliance

Electromagnetic Compatibility Information

This hardware has been tested and found to comply with the applicable regulatory requirements and limits for electromagnetic compatibility (EMC) as indicated in the hardware's Declaration of Conformity (DoC)¹. These requirements and limits are designed to provide reasonable protection against harmful interference when the hardware is operated in the intended electromagnetic environment. In special cases, for example when either highly sensitive or noisy hardware is being used in close proximity, additional mitigation measures may have to be employed to minimize the potential for electromagnetic interference.

While this hardware is compliant with the applicable regulatory EMC requirements, there is no guarantee that interference will not occur in a particular installation. To minimize the potential for the hardware to cause interference to radio and television reception or to experience unacceptable performance degradation, install and use this hardware in strict accordance with the instructions in the hardware documentation and the DoC¹.

If this hardware does cause interference with licensed radio communications services or other nearby electronics, which can be determined by turning the hardware off and on, you are encouraged to try to correct the interference by one or more of the following measures:

- Reorient the antenna of the receiver (the device suffering interference).
- Relocate the transmitter (the device generating interference) with respect to the receiver.
- Plug the transmitter into a different outlet so that the transmitter and the receiver are on different branch circuits.

Some hardware may require the use of a metal, shielded enclosure (windowless version) to meet the EMC requirements for special EMC environments such as, for marine use or in heavy industrial areas. Refer to the hardware's user documentation and the DoC¹ for product installation requirements.

When the hardware is connected to a test object or to test leads, the system may become more sensitive to disturbances or may cause interference in the local electromagnetic environment.

Operation of this hardware in a residential area is likely to cause harmful interference. Users are required to correct the interference at their own expense or cease operation of the hardware.

Changes or modifications not expressly approved by National Instruments could void the user's right to operate the hardware under the local regulatory rules.

¹ The Declaration of Conformity (DoC) contains important EMC compliance information and instructions for the user or installer. To obtain the DoC for this product, visit ni.com/certification, search by model number or product line, and click the appropriate link in the Certification column.

Contents

Chapter 1

DAQ System Overview

Safety Guidelines.....	1-2
Electromagnetic Compatibility Guidelines	1-2
DAQ Hardware.....	1-3
DAQ-STC	1-3
Calibration Circuitry.....	1-4
Internal or Self-Calibration.....	1-4
External Calibration.....	1-4
Cables and Accessories	1-4
Using Accessories with Devices.....	1-5
Custom Cabling.....	1-7
Field Wiring Considerations.....	1-7
Programming Devices in Software.....	1-8

Chapter 2

I/O Connector

68-Pin AO I/O Connector Pinouts.....	2-1
68-68-Pin Extended AO I/O Connector Pinout.....	2-5
Terminal Name Equivalents	2-5
I/O Connector Signal Descriptions.....	2-7
+5 V Power Source.....	2-10

Chapter 3

Analog Output

Analog Output Fundamentals.....	3-1
Analog Output Circuitry.....	3-1
DACs	3-1
DAC FIFO	3-1
AO Sample Clock.....	3-1
Reference Selection	3-1
Analog Output Resolution.....	3-2
Reference Selection (NI 6711/6713/DAQCard-6715 and NI 6731/6733 Only)	3-2
Reglitch Selection (NI 6711/6713 Only).....	3-2
Minimizing Glitches on the Output Signal.....	3-3
AO Data Generation Methods.....	3-3
Software-Timed Generations.....	3-3
Hardware-Timed Generations	3-3
Analog Output Triggering	3-4
Connecting Analog Output Signals.....	3-5

- Waveform Generation Timing Signals 3-5
 - Waveform Generation Timing Summary 3-5
 - AO Start Trigger Signal 3-5
 - Using a Digital Source 3-6
 - Outputting the AO Start Trigger Signal 3-6
 - AO Pause Trigger Signal 3-6
 - Using a Digital Source 3-7
 - AO Sample Clock Signal 3-7
 - Using an Internal Source 3-7
 - Using an External Source 3-7
 - Outputting the AO Sample Clock Signal 3-8
 - Other Timing Requirements 3-8
 - AO Sample Clock Timebase Signal 3-9
 - Master Timebase Signal 3-9
- Getting Started with AO Applications in Software 3-10

Chapter 4

Digital I/O

- Static DIO 4-2
- Digital Waveform Generation
 - (NI 6731/6733 Only) 4-2
 - DO Sample Clock Signal (NI 6731/6733 Only) 4-2
 - Using an Internal Source 4-3
 - Using an External Source 4-3
- Digital Waveform Acquisition
 - (NI 6731/6733 Only) 4-3
 - DI Sample Clock Signal (NI 6731/6733 Only) 4-4
 - Using an Internal Source 4-4
 - Using an External Source 4-4
- I/O Protection 4-4
- Power-On States 4-5
- Connecting Digital I/O Signals 4-5
- Getting Started with DIO Applications in Software 4-6

Chapter 5

Counters

- Counter Triggering 5-1
 - Start Trigger 5-1
 - Pause Trigger 5-1
- Counter Timing Signals 5-2
 - Counter Timing Summary 5-2
 - Counter 0 Source Signal 5-3
 - Counter 0 Gate Signal 5-3

Counter 0 Internal Output Signal.....	5-4
CTR 0 OUT Pin.....	5-5
Counter 0 Up/Down Signal.....	5-5
Counter 1 Source Signal.....	5-5
Counter 1 Gate Signal.....	5-6
Counter 1 Internal Output Signal.....	5-7
Counter 1 Up/Down Signal.....	5-7
Frequency Output Signal.....	5-7
Master Timebase Signal.....	5-8
Getting Started with Counter Applications in Software.....	5-8

Chapter 6

Programmable Function Interfaces (PFI)

Inputs.....	6-1
Outputs.....	6-1

Chapter 7

Digital Routing

Timing Signal Routing.....	7-1
Connecting Timing Signals.....	7-3
Routing Signals in Software.....	7-4

Chapter 8

Real-Time System Integration Bus (RTSI)

RTSI Triggers.....	8-1
Device and RTSI Clocks.....	8-3
Synchronizing Multiple Devices.....	8-3

Chapter 9

Bus Interface

MITE and DAQ-PnP.....	9-1
Using PXI with CompactPCI.....	9-1
Data Transfer Methods.....	9-2
Direct Memory Access (DMA).....	9-2
Interrupt Request (IRQ).....	9-2
Programmed I/O.....	9-2
Changing Data Transfer Methods between DMA and IRQ.....	9-2

Chapter 10

Triggering

Triggering with a Digital Source.....	10-1
---------------------------------------	------

Appendix A
Device-Specific Information

Appendix B
Troubleshooting

Appendix C
NI Services

Glossary

Index

DAQ System Overview

Figure 1-1 shows a typical DAQ system setup, which includes transducers, signal conditioning, cables that connect the various devices to the accessories, the analog output device, and the programming software. Refer to the [Using Accessories with Devices](#) section for a list of devices and their compatible accessories.

Figure 1-1. DAQ System Setup

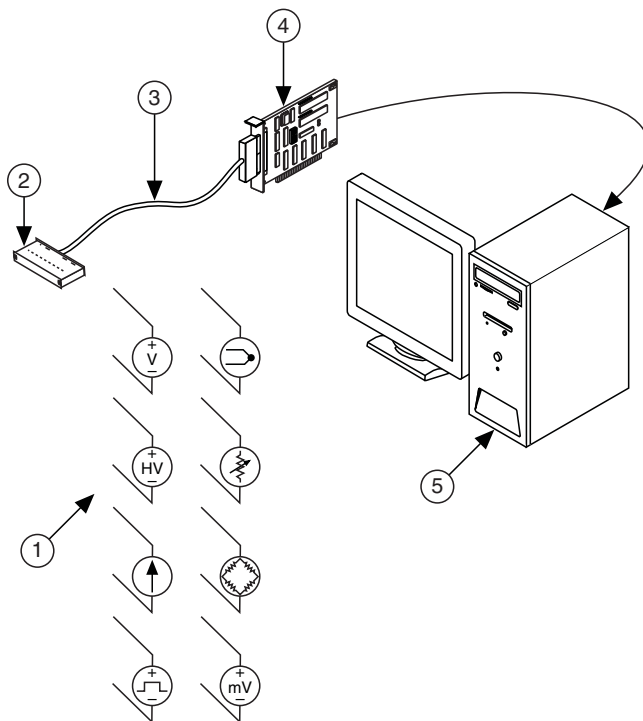

- 1 Sensors and Transducers
- 2 Terminal Block Accessory
- 3 Cable Assembly

- 4 DAQ Device
- 5 Personal Computer

Safety Guidelines

Operate the device only as described in this document.



Caution This icon denotes a caution, which advises you of precautions to take to avoid injury, data loss, or a system crash.



Caution The protection provided by the device can be impaired if it is used in a manner not described in this document. Misuse of the device can result in a hazard. You can compromise the safety protection built into the device if the device is damaged in any way. If the device is damaged, contact National Instruments for repair.



Caution Do not substitute parts or modify the device except as described in this document. Use the device only with the chassis, modules, accessories, and cables specified in the installation instructions.



Caution You must have all covers and filler panels installed during operation of the device. Do not operate the device without verifying that the cover is correctly attached and the device is completely closed.

Electromagnetic Compatibility Guidelines

This product was tested and complies with the regulatory requirements and limits for electromagnetic compatibility (EMC) stated in the product specifications. These requirements and limits provide reasonable protection against harmful interference when the product is operated in the intended operational electromagnetic environment.

This product is intended for use in industrial locations. However, harmful interference may occur in some installations, when the product is connected to a peripheral device or test object, or if the product is used in residential or commercial areas. To minimize interference with radio and television reception and prevent unacceptable performance degradation, install and use this product in strict accordance with the instructions in the product documentation.

Furthermore, any modifications to the product not expressly approved by National Instruments could void your authority to operate it under your local regulatory rules.



Caution To ensure the specified EMC performance, operate this product only with shielded cables and accessories. Do not use unshielded cables or accessories unless they are installed in a shielded enclosure with properly designed and shielded input/output ports and connected to the product using a shielded cable. If unshielded cables or accessories are not properly installed and shielded, the EMC specifications for the product are no longer guaranteed.



Caution To ensure the specified EMC performance of the DAQCard-6715, the length of the I/O cable must be no longer than 3 m (10 ft). For all other products, the length of the I/O cable must be no longer than 30 m (100 ft).

DAQ Hardware

DAQ hardware digitizes signals, performs D/A conversions to generate analog output signals, and measures and controls digital I/O signals. Figure 1-2 shows the components common to all AO Series devices. The following sections contain more information about specific components of the DAQ hardware.

Figure 1-2. Analog Output Block Diagram

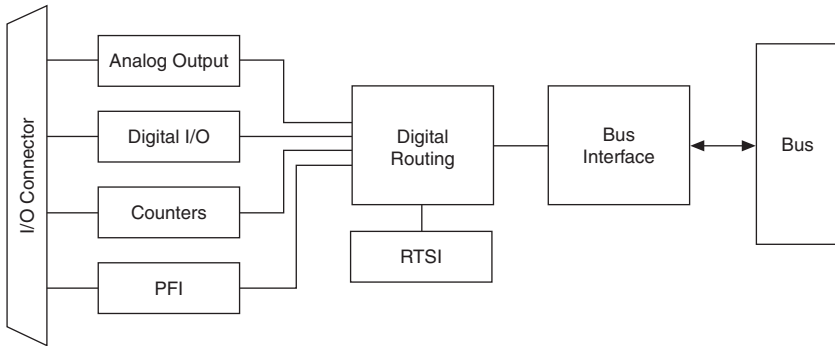

DAQ-STC

Analog output devices use the National Instruments DAQ system timing controller (DAQ-STC) for time-related functions. The DAQ-STC consists of the following three timing groups:

- AI—two 24-bit, two 16-bit counters (not used on AO Series devices)
- AO—three 24-bit, one 16-bit counter
- General-purpose counter/timer functions—two 24-bit counters

You can independently configure the groups for timing resolutions of 50 ns or 10 μ s. With the DAQ-STC, you can interconnect a wide variety of internal timing signals to other internal blocks. The interconnection scheme is flexible and completely software-configurable.

The DAQ-STC offers PFI lines to import external timing and trigger signals or to export internally generated clocks and triggers. The DAQ-STC also supports buffered operations, such as buffered waveform acquisition, buffered waveform generation, and buffered period measurement. It also supports numerous non-buffered operations, such as single pulse or pulse train generation, digital input, and digital output.

Calibration Circuitry

Calibration is the process of making adjustments to a measurement device to reduce errors associated with measurements. Without calibration, the measurement results of your device will drift over time and temperature. Calibration adjusts for these changes to improve measurement accuracy and ensure that your product meets its required specifications.

DAQ devices have high precision analog circuits that must be adjusted to obtain optimum accuracy in your measurements. Calibration determines what adjustments these analog circuits should make to the device measurements. During calibration, the value of a known, high precision measurement source is compared to the value your device acquires or generates. The adjustment values needed to minimize the difference between the known and measured values are stored in the EEPROM of the device as calibration constants. Before performing a measurement, these constants are read out of the EEPROM and are used to adjust the calibration hardware on the device. NI-DAQ determines when this is necessary and does it automatically. If you are not using NI-DAQ, you must load these values yourself.

You can calibrate AO Series devices in the following two ways.

Internal or Self-Calibration

Self-calibration is a process to adjust the device relative to a highly accurate and stable internal reference on the device. Self-calibration is similar to the autocalibration or autozero found on some instruments. You should perform a self-calibration whenever environmental conditions, such as ambient temperature, change significantly. To perform self-calibration, use the self-calibrate function or VI that is included with your driver software. Self-calibration requires no external connections.

External Calibration

External calibration is a process to adjust the device relative to a traceable, high precision calibration standard. The accuracy specifications of your device change depending on how long it has been since your last external calibration. National Instruments recommends that you calibrate your device at least as often as the intervals listed in the accuracy specifications.

For a detailed calibration procedure for AO Series devices, refer to the *AO Waveform Calibration Procedure for NI-DAQmx* document by selecting **Manual Calibration Procedures** at ni.com/calibration.

Cables and Accessories

NI offers a variety of products to use with Analog Output Series devices, including:

- BNC accessories
- Connector blocks with screw terminals
- I/O connector cables

- RTSI bus cables
- Low channel-count digital signal conditioning modules, devices, and accessories

For more specific information about these products, refer to ni.com.

The following sections contain information on how to select accessories for your AO Series device.

Using Accessories with Devices

Go to ni.com/info and enter the Info Code `AOcables` for the most current list of supported cables and accessories for the following analog output devices.

Table 1-1. Accessories and Cables for Analog Output Devices

Device	Accessories	
	Cables	Terminal Blocks
NI 6711/6713	SH68-68-EPM (Recommended, Shielded) R6868 (Low Cost)	BNC-2110 CA1000 CB-68LP CB-68LPR SCB-68 SCB-68A TBX-68 TB-2705 (PXI only)
NI DAQCard-6715	SHC68-68-EPM (Recommended, Shielded) SHC68U-68-EP (Shielded) RC68-68 (Unshielded)	BNC-2110 CA1000 CB-68LP CB-68LPR SCB-68A SCB-68 TBX-68
NI 6722	SH68-C68-S (Recommended, Shielded) RC68-68 (Low Cost)	BNC-2110 CA1000 CB-68LP CB-68LPR SCB-68A SCB-68 TBX-68

Table 1-1. Accessories and Cables for Analog Output Devices (Continued)

Device	Accessories	
	Cables	Terminal Blocks
NI 6723 (AO 0–7 & DIGITAL connector)	SH68-C68-S (Recommended, Shielded) RC68-68 (Low Cost)	BNC-2110 CA1000 CB-68LP CB-68LPR SCB-68A SBC-68 TBX-68
NI 6723 (AO 8–31 connector)	SH68-C68-S (Recommended, Shielded) RC68-68 (Low Cost)	BNC-2115 CA-1000 CB-68LP CB-68LPR SCB-68A SCB-68 TBX-68
NI 6731/6733	SH68-68-EPM (Recommended) R6868 (Low Cost)	BNC-2110 CA1000 CB-68LP CB-68LPR SCB-68 SCB-68A TBX-68 TB-2705 (PXI only)

Table 1-2. Overview of DAQ Accessories for Analog Output Devices

Accessory	Description
BNC-2110	BNC connector block for 68-pin analog output devices
BNC-2115	BNC connector block for extended I/O
CA-1000	Per-channel custom connectivity connector accessory enclosure
CB-68LP, CB-68LPR	68-pin, low-cost screw terminal block
SCB-68A, SCB-68	68-pin, shielded screw terminal block with breadboard areas. The SCB-68A is a newer design recommended for all new applications over the SCB-68.
TBX-68	68-pin, DIN rail-mountable screw terminal block

Custom Cabling

Follow these guidelines if you want to develop your own cable.

- Route the analog lines separately from the digital lines.
- When using a cable shield, use separate shields for the analog and digital halves of the cable. Failure to do so results in noise coupling into the analog signals from transient digital signals.

Table 1-3 shows the recommended connectors to use with the I/O connector on your AO device.

Table 1-3. Recommended AO Connectors

Device	Connector
NI 6711/6713	Honda 68-position, solder cup, female connector Honda backshell
NI DAQCard-6715	AMP 68-position, VHDCI AMP backshell
NI 6722/6723	AMP 68-position, VHDCI AMP backshell
NI 6731/6733	Honda 68-position, solder cup, female connector Honda backshell



Note When the NI DAQCard-6715 is in the upper PCMCIA slot, you can maintain access to the adjacent slot by using an inverted VHDCI connector.

For more information on the connectors used for DAQ devices, refer to the KnowledgeBase document, *Specifications and Manufacturers for Board Mating Connectors*. To access this document, go to ni.com/info and enter the info code `rdsmbm`.

Field Wiring Considerations

The following recommendations apply for all signal connections to the AO Series device.

- Separate the signal lines of the AO Series device from high-current or high-voltage lines. These lines can induce currents in or voltages on the signal lines of the AO Series device if they run in close parallel paths. To reduce the magnetic coupling between lines, separate them by a reasonable distance if they run in parallel, or run the lines at right angles to each other.
- Do *not* run signal lines through conduits that also contain power lines.
- Protect signal lines from magnetic fields caused by electric motors, welding equipment, breakers, or transformers by running them through special metal conduits.

Refer to the NI Developer Zone document, *Field Wiring and Noise Considerations for Analog Signals*, for more information. To access this document, go to ni.com/info and enter the Info Code `rdfwjn`.

Programming Devices in Software

National Instruments measurement devices are packaged with NI-DAQmx driver software, an extensive library of functions and VIs you can call from your application software, such as LabVIEW or LabWindows/CVI, to program all the features of your NI measurement devices. Driver software has an application programming interface (API), which is a library of VIs, functions, classes, attributes, and properties for creating applications for your device.

NI-DAQmx includes a collection of programming examples to help you get started developing an application. You can modify example code and save it in an application. You can use examples to develop a new application or add example code to an existing application.

To locate LabVIEW and LabWindows/CVI examples, open the National Instruments Example Finder:

- In LabVIEW, select **Help»Find Examples**.
- In LabWindows/CVI, select **Help»NI Example Finder**.

Measurement Studio, Visual Basic, and ANSI C examples are in the following directories:

- NI-DAQmx examples for Measurement Studio-supported languages are in the following directories:
 - NI-DAQ\Examples\MStudioVCxxxx
- Traditional NI-DAQ (Legacy) examples for Visual Basic are in the following two directories:
 - NI-DAQ\Examples\DotNETx.x
- NI-DAQmx examples for ANSI C are in the NI-DAQ\Examples\DAQmx ANSI C directory

For additional examples, refer to ni.com/examples.

I/O Connector

This chapter contains information about the AO Series I/O connectors.



Note Some hardware accessories may not yet reflect the NI-DAQmx terminal names. If you are using an AO Series device in Traditional NI-DAQ (Legacy), refer to Table 2-1 for the Traditional NI-DAQ (Legacy) signal names.

68-Pin AO I/O Connector Pinouts

Figure 2-1, Figure 2-2, and Figure 2-3 show the pinouts of 68-pin AO Series devices.

Figure 2-1. NI 6711/6731 68-Pin AO I/O Connector Pinout

AO GND	34	68	NC
NC	33	67	AO GND
AO GND	32	66	AO GND
AO GND	31	65	NC
NC	30	64	AO GND
AO GND	29	63	AO GND
NC	28	62	NC
AO GND	27	61	AO GND
AO GND	26	60	NC
AO 3	25	59	AO GND
AO GND	24	58	AO GND
AO GND	23	57	AO 2
AO 0	22	56	AO GND
AO 1	21	55	AO GND
AO EXT REF	20	54	AO GND
P0.4	19	53	D GND
D GND	18	52	P0.0
P0.1	17	51	P0.5
P0.6	16	50	D GND
D GND	15	49	P0.2
+5 V	14	48	P0.7
D GND	13	47	P0.3
D GND	12	46	NC
PFI 0	11	45	EXT STROBE
PFI 1	10	44	D GND
D GND	9	43	PFI 2
+5 V	8	42	PFI 3/CTR 1 SOURCE
D GND	7	41	PFI 4/CTR 1 GATE
PFI 5/AO SAMP CLK	6	40	CTR 1 OUT
PFI 6/AO START TRIG	5	39	D GND
D GND	4	38	PFI 7
PFI 9/CTR 0 GATE	3	37	PFI 8/CTR 0 SOURCE
CTR 0 OUT	2	36	D GND
FREQ OUT	1	35	D GND

NC = No Connect

Figure 2-2. NI 6713/DAQCard-6715/NI 6733 68-Pin AO I/O Connector Pinout

AO GND	34	68	NC
NC	33	67	AO GND
AO GND	32	66	AO GND
AO GND	31	65	AO 7
AO 6	30	64	AO GND
AO GND	29	63	AO GND
AO 5	28	62	NC
AO GND	27	61	AO GND
AO GND	26	60	AO 4
AO 3	25	59	AO GND
AO GND	24	58	AO GND
AO GND	23	57	AO 2
AO 0	22	56	AO GND
AO 1	21	55	AO GND
AO EXT REF	20	54	AO GND
P0.4	19	53	D GND
D GND	18	52	P0.0
P0.1	17	51	P0.5
P0.6	16	50	D GND
D GND	15	49	P0.2
+5 V	14	48	P0.7
D GND	13	47	P0.3
D GND	12	46	NC
PFI 0	11	45	EXT STROBE
PFI 1	10	44	D GND
D GND	9	43	PFI 2
+5 V	8	42	PFI 3/CTR 1 SOURCE
D GND	7	41	PFI 4/CTR 1 GATE
PFI 5/AO SAMP CLK	6	40	CTR 1 OUT
PFI 6/AO START TRIG	5	39	D GND
D GND	4	38	PFI 7
PFI 9/CTR 0 GATE	3	37	PFI 8/CTR 0 SOURCE
CTR 0 OUT	2	36	D GND
FREQ OUT	1	35	D GND

NC = No Connect

Figure 2-3. NI 6722 68-Pin AO I/O Connector Pinout

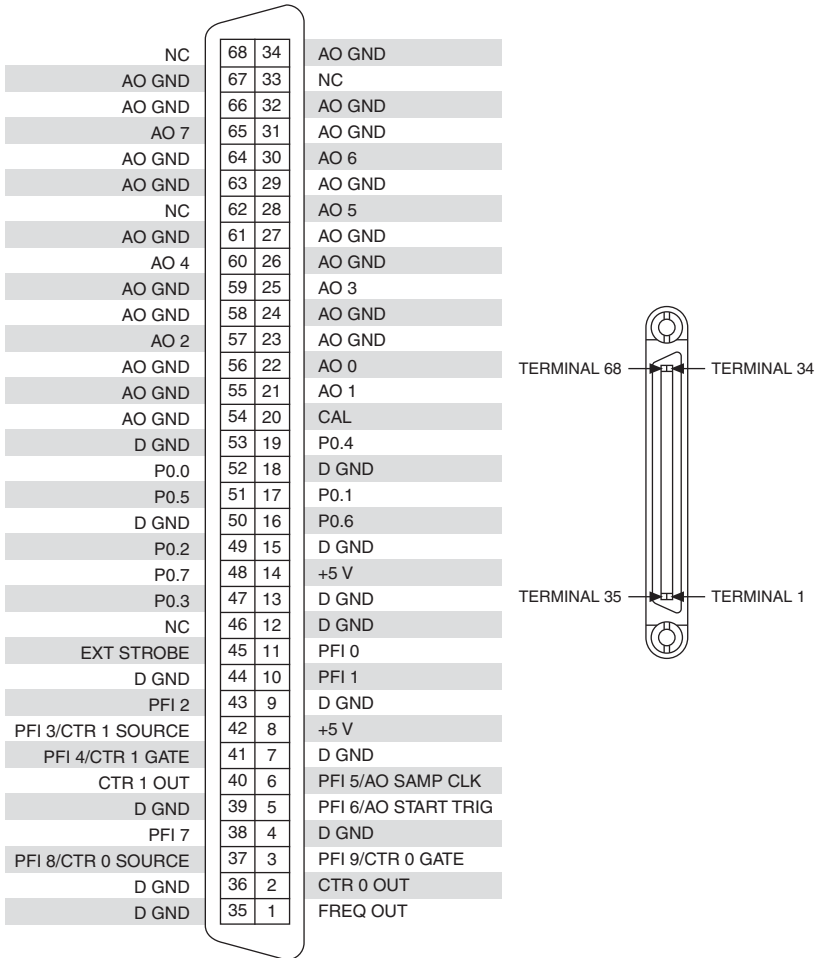

NC = No Connect

For a detailed description of each signal, refer to [I/O Connector Signal Descriptions](#).

68-68-Pin Extended AO I/O Connector Pinout

The NI 6723 has two 68-pin I/O connectors. Figure 2-4 shows the pin assignments for both connectors on the NI 6723.

Figure 2-4. NI 6723 68-68-Pin Extended AO I/O Connector Pinout

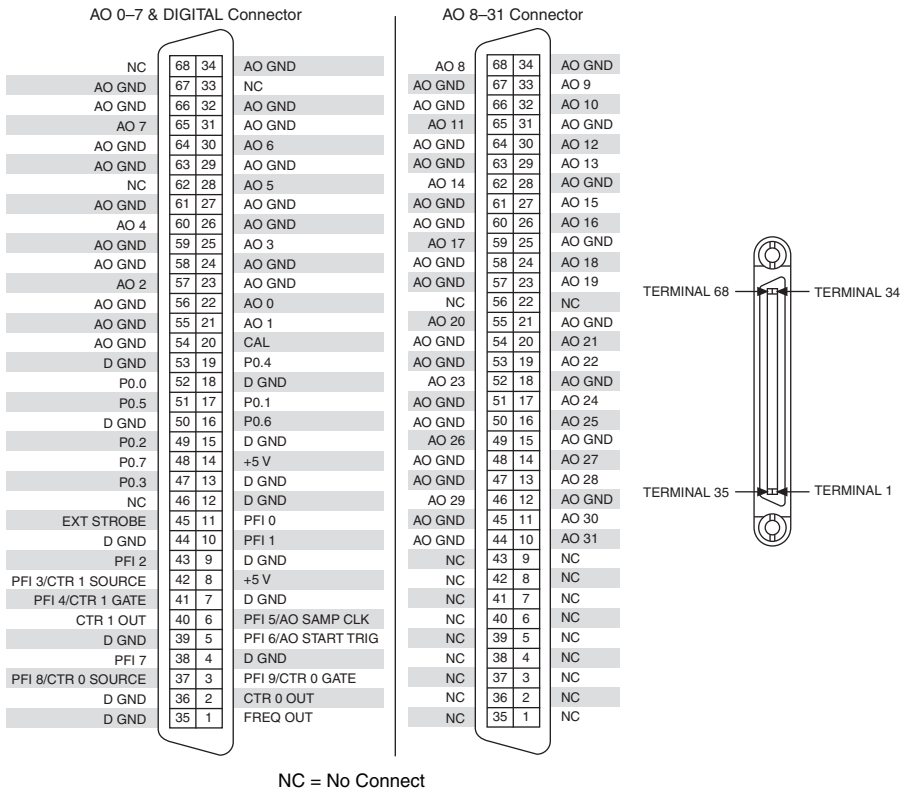

For a detailed description of each signal, refer to [I/O Connector Signal Descriptions](#).

Terminal Name Equivalents

With NI-DAQmx, National Instruments has revised its terminal names so they are easier to understand and more consistent among National Instruments hardware and software products. The revised terminal names used in this document are usually similar to the names they replace. Refer to Table 2-1 for a list of Traditional NI-DAQ (Legacy) terminal names and their NI-DAQmx equivalents.

Table 2-1. Terminal Name Equivalents.

Traditional NI-DAQ (Legacy)	NI-DAQmx
ACH#	AI #
ACH# +	AI # +
ACH# -	AI # -
ACHGND	AI GND
AIGND	AI GND
AISENSE	AI SENSE
AISENSE2	AI SENSE 2
AOGND	AO GND
CONVERT*	AI CONV CLK or AI CONV
DAC0OUT	AO 0
DAC1OUT	AO 1
DGND	D GND
DIO_#	P0.#
DIO#	P0.#
DIOA#, DIOB#, DIOC#...	P0.#, P1.#, P2.#...
EXTREF	AO EXT REF or EXT REF
EXT_STROBE	EXT STROBE
FREQ_OUT	FREQ OUT or F OUT
GPCTR0_GATE	CTR 0 GATE
GPCTR0_OUT	CTR 0 OUT
GPCTR0_SOURCE	CTR 0 SOURCE or CTR 0 SRC
GPCTR1_GATE	CTR 1 GATE
GPCTR1_OUT	CTR 1 OUT
GPCTR1_SOURCE	CTR 1 SOURCE or CTR 1 SRC
PA#, PB#, PC#...	P0.#, P1.#, P2.#...

Table 2-1. Terminal Name Equivalents. (Continued)

Traditional NI-DAQ (Legacy)	NI-DAQmx
PFI#	PFI #
PFI_#	PFI #
SCANCLK	AI HOLD COMP or AI HOLD
SISOURCE	AI Sample Clock Timebase
STARTSCAN	AI SAMP CLK or AI SAMP
TRIG1	AI START TRIG or AI START
TRIG2	AI REF TRIG or REF TRIG
UISOURCE	AO Sample Clock Timebase
UPDATE	AO SAMP CLK or AO SAMP
WFTRIG	AO START TRIG or AO START

I/O Connector Signal Descriptions

Table 2-2 describes the signals found on the I/O connectors.

Table 2-2. I/O Connector Signal Descriptions

I/O Connector Pin	Reference	Direction	Signal Description
AO GND	—	—	Analog Output Ground —The AO voltages and the external reference voltage are referenced to these pins.
AO <0..31>	AO GND	Output	Analog Output channels 0 through 31 —These pins supply the voltage outputs of their respective channels.
D GND	—	—	Digital Ground —These pins supply the reference for the digital signals at the I/O connector as well as the +5 VDC supply.
P0.<0..7>	D GND	Input or Output	Digital I/O signals —These pins drive and receive digital signals. P0.6 and P0.7 can control the up/down signal of Counters 0 and 1, respectively.

Table 2-2. I/O Connector Signal Descriptions (Continued)

I/O Connector Pin	Reference	Direction	Signal Description
+5 V	D GND	Output	+5 VDC source —These pins provide +5 V power.
AO EXT REF	D GND	Input	External Reference —This pin is the external reference input for the AO circuitry.
AI HOLD COMP	D GND	Output	AI Hold Complete —This pin is used to control some NI accessories.
EXT STROBE	D GND	Output	External Strobe —This pin is used to control some NI accessories.
PFI 0	D GND	Input	PFI 0 —As an input for digital signals, this pin is a general-purpose input terminal. For an explanation of PFI signals, refer to the Connecting Timing Signals section.
PFI 1	D GND	Input	PFI 1 —As an input, this is a general-purpose input terminal.
PFI 2	D GND	Input	PFI 2 —As an input, this pin is a general-purpose input terminal.
PFI 3/CTR 1 SOURCE	D GND	Input	PFI 3 —As an input, this pin is a general-purpose input terminal. This is the default input for the Ctr1Source signal.
		Output	Counter 1 Source Signal —As an output, this pin emits the selected Ctr1Source signal. This signal reflects the actual source signal connected to Counter 1. For more information, refer to Chapter 5, Counters .
PFI 4/CTR 1 GATE	D GND	Input	PFI 4 —As an input, this pin is a general-purpose input terminal. This is the default input for the Ctr1Gate signal.
		Output	Counter 1 Gate Signal —As an output, this pin emits the selected Ctr1Gate signal. This signal reflects the actual gate signal connected to Counter 1. For more information, refer to Chapter 5, Counters .

Table 2-2. I/O Connector Signal Descriptions (Continued)

I/O Connector Pin	Reference	Direction	Signal Description
CTR 1 OUT	D GND	Output	Counter 1 Output Signal —This pin emits the Ctr1InternalOutput signal. For more information, refer to Chapter 5, <i>Counters</i> .
PFI 5/AO SAMP CLK	D GND	Input	PFI 5 —As an input, this pin is a general-purpose input terminal.
		Output	AO Sample Clock Signal —As an output, this pin emits the ao/SampleClock signal. A high-to-low transition of this signal indicates a new sample is being generated. For more information, refer to Chapter 3, <i>Analog Output</i> .
PFI 6/AO START TRIG	D GND	Input	PFI 6 —As an input, this pin is a general-purpose input terminal. This is the default input for the ao/StartTrigger signal.
		Output	AO Start Trigger Signal —As an output, this pin emits the ao/StartTrigger signal. A low-to-high transition of this signal indicates the start of a generation. For more information, refer to Chapter 3, <i>Analog Output</i> .
PFI 7	D GND	Input	PFI 7 —As an input, this pin is a general-purpose input terminal.
PFI 8/CTR 0 SOURCE	D GND	Input	PFI 8 —As an input, this pin is a general-purpose input terminal and can also be used to route signals directly to the RTSI bus. This is the default input for the Ctr0Source signal.
		Output	Counter 0 Source Signal —As an output, this pin emits the Ctr0Source signal. This signal reflects the actual source signal connected to Counter 0. For more information, refer to Chapter 5, <i>Counters</i> .

Table 2-2. I/O Connector Signal Descriptions (Continued)

I/O Connector Pin	Reference	Direction	Signal Description
PFI 9/CTR 0 GATE	D GND	Input	PFI 9 —As an input, this pin is a general-purpose input terminal and can also be used to route signals directly to the RTSI bus. This is the default input for the Ctr0Gate signal.
		Output	Counter 0 Gate Signal —As an output, this pin emits the Ctr0Gate signal. This signal reflects the actual gate signal connected to Counter 0. For more information, refer to Chapter 5, <i>Counters</i> .
CTR 0 OUT	D GND	Input	Counter 0 Output Signal —As an input, this pin can be used to route signals directly to the RTSI bus. For more information, refer to Chapter 5, <i>Counters</i> .
		Output	As an output, this pin emits the Ctr0InternalOutput signal.
CAL	D GND	Input	Calibration —Voltage input for external calibration. For more information on using this signal, refer to the <i>AO Waveform Calibration Procedure for NI-DAQmx</i> document by selecting Manual Calibration Procedures at ni.com/calibration .
FREQ OUT	D GND	Output	Frequency Output Signal —This output is from the frequency generator. For more information, refer to Chapter 5, <i>Counters</i> .



Caution Connections that exceed any of the maximum ratings of input or output signals on the AO Series device can damage the device and the computer. Refer to the specifications document for your device for more information on maximum input ratings for each signal. NI is *not* liable for any damage resulting from signal connections that exceed the maximum ratings.

+5 V Power Source

The +5 V pins on the I/O connector supply +5 V power. You can use these pins, referenced to D GND, to power external circuitry. A self-resetting fuse protects the supply from overcurrent

conditions. The fuse resets automatically within a few seconds after the overcurrent condition is removed.

Power rating: +4.65 to +5.25 VDC at 1 A (0.75 A for the DAQCard-6715)

The +5 V line on the connector of the DAQCard-6715 is fused at 0.75 A. However, the actual current available can be limited below this value by the host computer. NI recommends limiting current from this line to 250 mA.



Caution Never connect these +5 V power pins to analog or digital ground or to any other voltage source on the AO Series device or any other device. Doing so can damage the device and the computer. NI is *not* liable for damage resulting from such a connection.

Analog Output

Figure 3-1 shows the analog output circuitry of AO Series devices.

Figure 3-1. Analog Output Circuitry Block Diagram

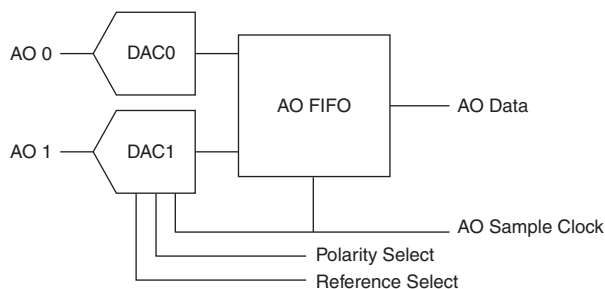

Analog Output Fundamentals

Analog Output Circuitry

DACs

Digital-to-analog converters (DACs) convert digital codes to analog voltages.

DAC FIFO

The DAC FIFO enables analog output waveform generation. It is a first-in-first-out (FIFO) memory buffer between the computer and the DACs that allows you to download all the points of a waveform to your board without host computer interaction.

AO Sample Clock

The DAC reads a sample from the FIFO with every cycle of the AO Sample Clock signal and generates the AO voltage. For more information on the AO Sample Clock signal, refer to the [Waveform Generation Timing Signals](#) section.

Reference Selection

(NI 6711/6713/DAQCard-6715 and NI 6731/6733 Only) Reference selection allows you to set the AO range. Refer to Table 3-1 to set the range for your device.

Table 3-1. AO Reference Selection Options

AO Range	Polarity	Reference Select
±10 V	Bipolar	Internal
±EXT REF	Bipolar	AO External Reference Signal

Analog Output Resolution

You can calculate the least significant bit (LSB), or the minimal allowed voltage change, on a voltage output on your AO Series device as follows:

$$\text{LSB} = \text{output voltage range} / 2^{\text{resolution of your device}}$$

where the output range is determined by your reference selection. Using AO EXT REF, you can reduce the output voltage range and lower the LSB, the minimum allowed voltage change. For more information on using the AO External Reference signal, refer to the [Reference Selection \(NI 6711/6713/DAQCard-6715 and NI 6731/6733 Only\)](#) section.

The following equation is an example of this formula using the NI 6731/6733.

$$\frac{20 \text{ V}}{65,536} = 305 \mu\text{V}$$

The denominator in the equation is derived from $2^{16} = 65,536$, since the NI 6731/6733 devices use 16-bit DACs.

Reference Selection (NI 6711/6713/DAQCard-6715 and NI 6731/6733 Only)

You can connect each DAC to the device internal reference of 10 V or to the external reference signal connected to the external reference (AO EXT REF) pin on the I/O connector. This signal applied to AO EXT REF should be within ±11 V of AO GND. You do not need to configure all channels for the same mode. Using AO EXT REF to reduce the output voltage range results in a higher resolution at the adjusted range.

Reglitch Selection (NI 6711/6713 Only)

In normal operation, a DAC output glitches whenever it is updated with a new value. The glitch energy differs from code to code and appears as distortion in the frequency spectrum. Each AO channel contains a reglitch circuit that generates uniform glitch energy at every code rather than large glitches at the major code transitions. This uniform glitch energy appears as a multiple of the update rate in the frequency spectrum. This reglitch circuit does not eliminate the glitches; it only makes them more uniform in size. By default, reglitching is disabled for all channels; however, you can use NI-DAQ to independently enable reglitching for each channel.

Minimizing Glitches on the Output Signal

When you use a DAC to generate a waveform, you may observe glitches on the output signal. These glitches are normal; when a DAC switches from one voltage to another, it produces glitches due to released charges. The largest glitches occur when the most significant bit (MSB) of the DAC code switches. You can build a lowpass deglitching filter to remove some of these glitches, depending on the frequency and nature of the output signal. Visit ni.com/support for more information on minimizing glitches.

AO Data Generation Methods

When performing an analog output operation, there are several different data generation methods available. You can either perform software-timed or hardware-timed generations. Hardware-timed generations can be non-buffered or buffered.

Software-Timed Generations

With a software-timed generation, software controls the rate at which data is generated. Software sends a separate command to the hardware to initiate each DAC conversion. In NI-DAQmx, software-timed generations are referred to as On Demand timing. Software-timed generations are also referred to as immediate or static operations. They are typically used for writing a single value out, such as a constant DC voltage.

Hardware-Timed Generations

With a hardware-timed generation, a digital hardware signal controls the rate of the generation. This signal can be generated internally on your device or provided externally.

Hardware-timed generations have several advantages over software-timed generations:

- The time between samples can be much shorter.
- The timing between samples can be deterministic.
- Hardware-timed generations can use hardware triggering. For more information, refer to Chapter 10, [Triggering](#).

Hardware-timed operations can be buffered or non-buffered. A buffer is a temporary storage in computer memory for acquired or to-be-generated samples.

Buffered

In a buffered generation, data is moved from a PC buffer to the DAQ device's onboard FIFO using DMA or interrupts before it is written to the DACs one sample at a time. Buffered generations typically allow for much faster transfer rates than non-buffered generations because data is moved in large blocks, rather than one point at a time. For more information on DMA and interrupt requests, refer to the [Data Transfer Methods](#) section of Chapter 9, [Bus Interface](#).

One property of buffered I/O operations is the sample mode. The sample mode can be either finite or continuous.

Finite sample mode generation refers to the generation of a specific, predetermined number of data samples. After the specified number of samples has been written out, the generation stops.

Continuous generation refers to the generation of an unspecified number of samples. Instead of generating a set number of data samples and stopping, a continuous generation continues until you stop the operation. There are several different methods of continuous generation that control what data is written. These methods are regeneration, FIFO regeneration and non-regeneration modes.

Regeneration is the repetition of the data that is already in the buffer. Standard regeneration is when data from the PC buffer is continually downloaded to the FIFO to be written out. New data can be written to the PC buffer at any time without disrupting the output.

With FIFO regeneration, the entire buffer is downloaded to the FIFO and regenerated from there. After the data is downloaded, new data cannot be written to the FIFO. To use FIFO regeneration, the entire buffer must fit within the FIFO size. The advantage of using FIFO regeneration is that it does not require communication with the main host memory when the operation is started, thereby preventing any problems that may occur due to excessive bus traffic.

With non-regeneration, old data will not be repeated. New data must be continually written to the buffer. If the program does not write new data to the buffer at a fast enough rate to keep up with the generation, the buffer will underflow and cause an error.

Non-Buffered

In hardware-timed non-buffered generations, data is written directly to the FIFO on the device. Typically, hardware-timed non-buffered operations are used to write single samples with known time increments between them and good latency.

Analog Output Triggering

Analog output supports two different triggering actions: start and pause. A digital hardware trigger can initiate these actions. All AO Series devices support digital triggering.

The *AO Start Trigger Signal* section and *AO Pause Trigger Signal* section contain information about the analog output trigger signals.

Refer to Chapter 10, *Triggering*, for more information about triggers.

Connecting Analog Output Signals

Figure 3-2 shows how to connect loads to AO 0 and AO 1.

Figure 3-2. Analog Output Connections for AO 0 and AO 1

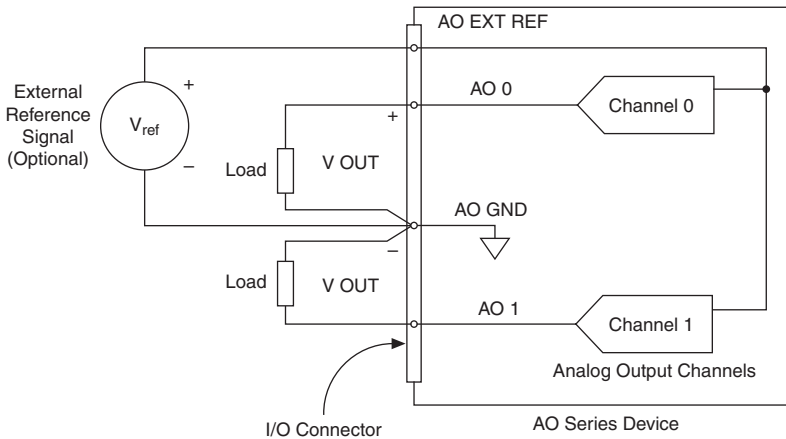

Note AO EXT REF is not available on the NI 6722/6723.

Waveform Generation Timing Signals

Waveform Generation Timing Summary

There is one AO Sample Clock that causes all AO channels to update simultaneously. Figure 3-3 summarizes the timing and routing options provided by the analog output timing engine.

Figure 3-3. Analog Output Engine Routing Options

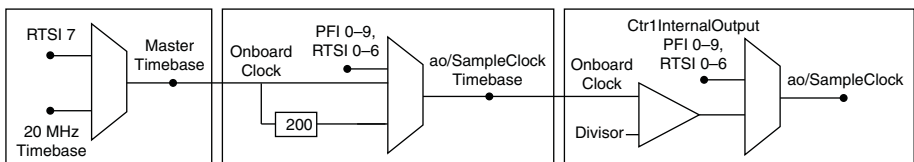

AO Start Trigger Signal

You can use the AO Start Trigger (ao/StartTrigger) signal to initiate a waveform generation. If you do not use triggers, you begin a generation with a software command.

Using a Digital Source

To use `ao/StartTrigger`, specify a source and an edge. The source can be an external signal connected to any PFI or RTSI <0..6> pin. The source can also be one of several internal signal on your DAQ device. Refer to *Device Routing in MAX* in the *NI-DAQmx Help* or the *LabVIEW Help* for more information.

Figure 3-4 shows the timing requirements of the `ao/StartTrigger` digital source.

Figure 3-4. `ao/StartTrigger` Timing Requirements

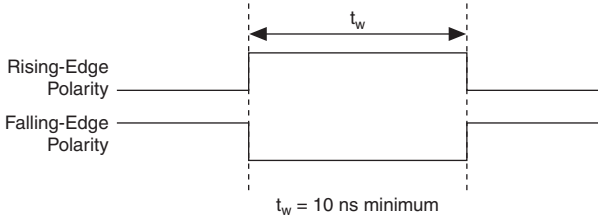

Outputting the AO Start Trigger Signal

You can configure the PFI 6/AO START TRIG pin to output the `ao/StartTrigger` signal. The output pin reflects the `ao/StartTrigger` signal regardless of what signal you specify as its source.

The output is an active high pulse. Figure 3-5 shows the timing behavior of the PFI 6/AO START TRIG pin when the pin is an output.

Figure 3-5. PFI 6/AO START TRIG Timing Behavior

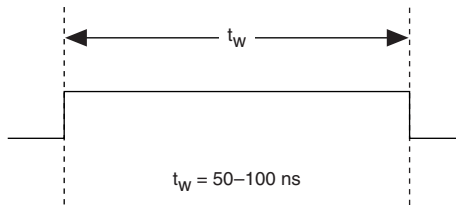

The PFI 6/AO START TRIG pin is configured as an input by default.

AO Pause Trigger Signal

You can use the AO Pause trigger signal (`ao/PauseTrigger`) to mask off samples in a DAQ sequence. That is, when `ao/PauseTrigger` is active, no samples occur.

The `ao/PauseTrigger` does not stop a sample that is in progress. The pause does not take effect until the beginning of the next sample. This signal is not available as an output.

Using a Digital Source

To use ao/Pause Trigger, specify a source and a polarity. The source can be an external signal connected to any PFI or RTSI <0..6> pin. The source can also be one of several other internal signals on your DAQ device. Refer to *Device Routing in MAX* in the *NI-DAQmx Help* or the *LabVIEW Help* for more information.

Also, specify whether the samples are paused when ao/PauseTrigger is at a logic high or low level.

AO Sample Clock Signal

You can use the AO Sample Clock (ao/SampleClock) signal to initiate AO samples. Each sample updates the outputs of all of the DACs.

The source of the ao/SampleClock signal can be internal or external. You can specify whether the DAC update begins on the rising edge or falling edge of the ao/SampleClock signal.

Using an Internal Source

By default, ao/SampleClock is created internally by dividing down the ao/SampleClockTimebase. For more information, refer to the *AO Sample Clock Timebase Signal* section.

Several other internal signals can be routed to the sample clock. Refer to *Device Routing in MAX* in the *NI-DAQmx Help* or the *LabVIEW Help* for more information.

Using an External Source

You can use a signal connected to any PFI or RTSI <0..6> pin as the source of ao/SampleClock. Figure 3-6 shows the timing requirements of the ao/SampleClock source.

Figure 3-6. ao/SampleClock Timing Requirements

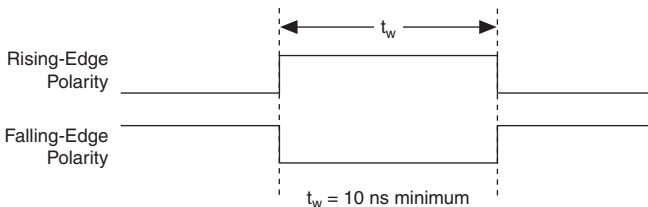

Outputting the AO Sample Clock Signal

You can configure the PFI 5/AO SAMP CLK pin to output the ao/SampleClock signal. The output pin reflects the ao/SampleClock signal regardless of what signal you specify as its source.

The output is an active high pulse. Figure 3-7 shows the timing behavior of the PFI 5/AO SAMP CLK pin when the pin is an output.

Figure 3-7. PFI 5/AO SAMP CLK as an Output

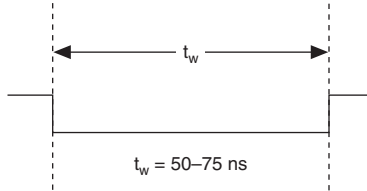

The PFI 5/AO SAMP CLK is configured as an input by default.

Other Timing Requirements

A counter on your device internally generates ao/SampleClock unless you select some external source. The ao/StartTrigger signal starts this counter. It is stopped automatically by hardware after a finite acquisition completes or manually through software. When using an internally generated ao/SampleClock in NI-DAQmx, you can also specify a configurable delay from the ao/StartTrigger to the first ao/SampleClock pulse. By default, this delay is two ticks of the ao/SampleClockTimebase signal.

Figure 3-8 shows the relationship of the ao/SampleClock signal to the ao/StartTrigger signal.

Figure 3-8. ao/SampleClock and ao/StartTrigger

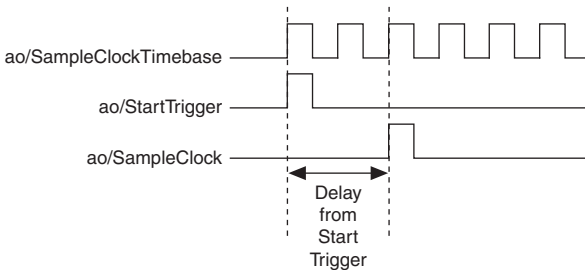

AO Sample Clock Timebase Signal

You can select any PFI or RTSI pin as well as many other internal signals as the AO Sample Clock Timebase (ao/SampleClockTimebase) signal. This signal is not available as an output on the I/O connector. The ao/SampleClockTimebase is divided down to provide the Onboard Clock source for the ao/SampleClock. You specify whether the samples begin on the rising or falling edge of ao/SampleClockTimebase.

You might use the ao/SampleClockTimebase signal if you want to use an external sample clock signal, but need to divide the signal down. If you want to use an external sample clock signal, but do not need to divide the signal, then you should use the ao/SampleClock signal rather than the ao/SampleClockTimebase. If you do not specify an external sample clock timebase, NI-DAQ uses the Onboard Clock.

Figure 3-9 shows the timing requirements for the ao/SampleClockTimebase signal.

Figure 3-9. ao/SampleClockTimebase Timing Requirements

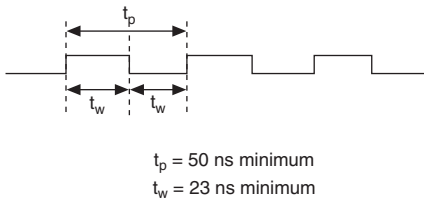

The maximum allowed frequency is 20 MHz, with a minimum pulse width of 10 ns high or low. There is no minimum frequency.

Unless you select an external source, either the 20MHzTimebase or 100kHzTimebase generates the ao/SampleClockTimebase signal.

Master Timebase Signal

The Master Timebase (MasterTimebase) signal, or Onboard Clock, is the timebase from which all other internally generated clocks and timebases on the board are derived. It controls the timing for the analog output and counter subsystems. It is available as an output on the I/O connector, but you must use one or more counters to do so.

The maximum allowed frequency for the MasterTimebase is 20 MHz, with a minimum pulse width of 23 ns high or low. There is no minimum frequency limitation.

The two possible sources for the MasterTimebase signal are the internal 20MHzTimebase signal or an external signal through RTSI 7. Typically the 20MHzTimebase signal is used as the MasterTimebase unless you wish to synchronize multiple devices, in which case, you should use RTSI 7. Refer to Chapter 8, *Real-Time System Integration Bus (RTSI)*, for more information on which signals are available through RTSI.

Figure 3-10 shows the timing requirements for MasterTimebase.

Figure 3-10. MasterTimebase Timing Requirements

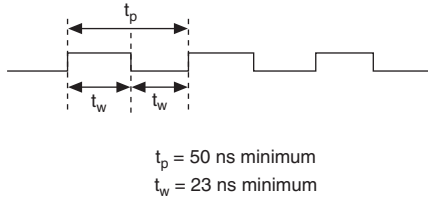

Getting Started with AO Applications in Software

You can use the AO Series device in the following analog output applications.

- Single-Point Generation
- Finite Generation
- Continuous Generation
- Waveform Generation

You can perform these generations through programmed I/O, interrupt, or DMA data transfer mechanisms. Some of the applications also use start triggers and pause triggers.



Note For more information about programming analog output applications and triggers in software, refer to the *NI-DAQmx Help*.

Digital I/O

AO Series devices contain eight lines of bidirectional DIO signals that support the following features:

- Direction and function of each terminal, individually controllable
- High-speed digital waveform generation (NI 6731/6733 only)
- High-speed digital waveform acquisition (NI 6731/6733 only)

Figure 4-1 shows the circuitry of one DIO line.

Figure 4-1. AO Series Digital I/O Block Diagram

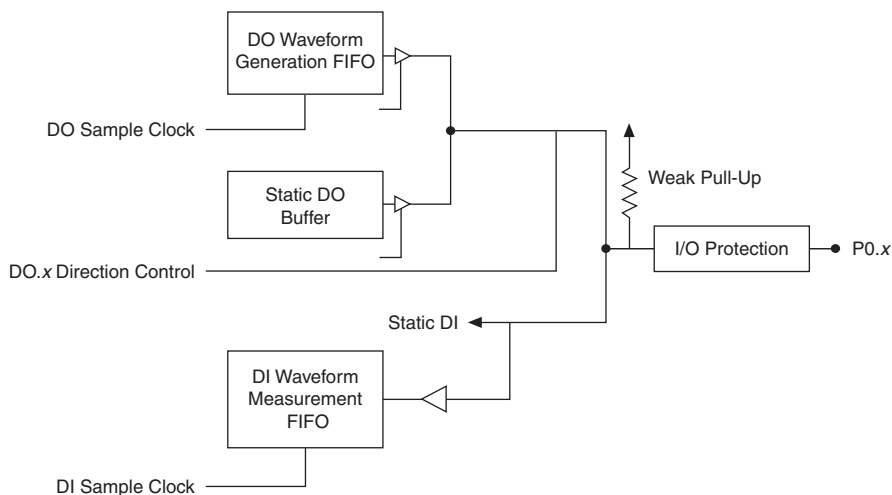

The DIO terminals are named P0.<0..7> on the I/O connector.

The voltage input and output levels and the current drive levels of the DIO lines are listed in the specifications of your device.

Static DIO

Each DIO line can be used as a static DI or DO line. You can use static DIO lines to monitor or control digital signals. Each DIO can be individually configured as a digital input (DI) or digital output (DO). All samples of static DI lines and updates of DO lines are software-timed.

P0.6 and P0.7 also can control the up/down input of general-purpose Counters 0 and 1, respectively. The up/down control signals, Counter 0 Up/Down and Counter 1 Up/Down, are input-only and do not affect the operation of the DIO lines. For more information, refer to Chapter 5, *Counters*.

Digital Waveform Generation (NI 6731/6733 Only)

The NI 6731/6733 can generate digital waveforms. This behavior is also referred to as correlated digital I/O because there is no dedicated clock source for the digital operation. Refer to the *DO Sample Clock Signal (NI 6731/6733 Only)* section for a list of possible sources.

The DO waveform generation FIFO stores the digital samples. The NI 6731/6733 can use DMA transfers to move data from the system memory to the DO waveform generation FIFO. The DAQ device moves samples from the FIFO to the DIO terminals on each rising or falling edge of a clock signal, do/SampleClock. For more information on DMA transfers, refer to the *Direct Memory Access (DMA)* section of Chapter 9, *Bus Interface*.

You can configure each DIO line to be an input, a static output, or a digital waveform generation output.

DO Sample Clock Signal (NI 6731/6733 Only)

Use the DO Sample Clock (do/SampleClock) signal to update the DO pins with the next sample from the DO waveform generation FIFO. Because there is no dedicated internal clock for timed digital operations, you can use an external signal or one of several internal signals as the DO Sample Clock. You can correlate digital and analog samples in time by choosing the same signal as the source of the DO Sample Clock, AI Sample Clock, or DI Sample Clock.

If the DAQ device receives a do/SampleClock when the FIFO is empty, the DAQ device reports an underflow error to the host software.

Using an Internal Source

To use do/SampleClock with an internal source without making any external connections, specify the signal source and the polarity of the signal. The source can be one of the following signals:

- AO Sample Clock
- Counter 0 Out

Program the DAQ device to update the DIO pins on the rising edge or falling edge of do/SampleClock.

Using an External Source

You can use a signal connected to any RTSI <0..6> pin as the source of do/SampleClock. You can generate samples on the rising or falling edge of do/SampleClock.

Any PFI line that can be routed to RTSI can also be used as the clock source. Refer to *Device Routing in MAX* in the *NI-DAQmx Help* or the *LabVIEW Help* for more information.

You must ensure that the time between two active edges of the do/SampleClock is not too short. If the time is too short, the DO waveform generation FIFO is not able to read the next sample fast enough.

Digital Waveform Acquisition (NI 6731/6733 Only)

The NI 6731/6733 can acquire digital waveforms. This behavior is also referred to as correlated digital I/O because there is no dedicated clock source for the digital operation. Refer to the [DI Sample Clock Signal \(NI 6731/6733 Only\)](#) section for a list of possible sources.

The DI waveform acquisition FIFO stores the digital samples. The NI 6731/6733 can use DMA transfers to move data from the DI waveform acquisition FIFO to system memory. The DAQ device samples the DIO lines on each rising or falling edge of a clock signal, di/SampleClock. For more information on DMA transfers, refer to the [Direct Memory Access \(DMA\)](#) section of Chapter 9, [Bus Interface](#).

You can configure each DIO line to be an output, a static input, or a digital waveform acquisition input.

DI Sample Clock Signal (NI 6731/6733 Only)

Use the DI Sample Clock (`di/SampleClock`) signal to sample the P0.<0..7> terminals and store the result in the DI waveform acquisition FIFO. Because there is no dedicated internal clock for timed digital operations, you can use an external signal or one of several internal signals as the DI Sample Clock. You can correlate digital and analog samples in time by choosing the same signal as the source of the DI Sample Clock, AI Sample Clock, or DO Sample Clock.

If the DAQ device receives a `di/SampleClock` when the FIFO is full, the DAQ device reports an overflow error to the host software.

Using an Internal Source

To use `di/SampleClock` with an internal source, specify the signal source and the polarity of the signal. The source can be any of the following signals:

- AO Sample Clock
- Counter 0 Out

Program the DAQ device to sample the DIO terminals on the rising edge or falling edge of `di/SampleClock`.

Using an External Source

You can use a signal connected to any RTSI <0..6> pin as the source of `di/SampleClock`. You can sample data on the rising or falling edge of `di/SampleClock`.

Any PFI line that can be routed to RTSI can also be used as the clock source. Refer to *Device Routing in MAX* in the *NI-DAQmx Help* or the *LabVIEW Help* for more information.

You must ensure that the time between two active edges of the `di/SampleClock` is not too short. If the time is too short, the DI waveform generation FIFO is not able to store the sample fast enough.

I/O Protection

To minimize the risk of damaging the DIO and PFI terminals of your device, follow these guidelines.

- If you configure a PFI or DIO line as an output, do not connect it to any external signal source, ground signal, or power supply.
- If you configure a PFI or DIO line as an output, understand the current requirements of the load connected to these signals. Do not exceed the specified current output limits of the DAQ device. NI has several signal conditioning solutions for digital applications requiring high current drive.

- If you configure a PFI or DIO line as an input, do not drive the line with voltages outside of its normal operating range. The PFI or DIO lines have a smaller operating range than the AI signals.
- Treat the DAQ device as you would treat any static sensitive device. Always properly ground yourself and the equipment when handling the DAQ device or connecting to it.

Power-On States

At system startup and reset, the hardware sets all PFI and DIO lines to high-impedance inputs. The DAQ device does not drive the signal high or low. Each line has a weak pull-up resistor connected to it, as described in the specifications of your device.

Connecting Digital I/O Signals

The DIO signals, P0.<0..7>, are referenced to D GND. You can individually program each line as an input or output. Figure 4-2 shows P0.<0..3> configured for digital input and P0.<4..7> configured for digital output. Digital input applications include receiving TTL signals and sensing external device states, such as the state of the switch shown in the figure. Digital output applications include sending TTL signals and driving external devices, such as the LED shown in the figure.

Figure 4-2. Digital I/O Signal Connections

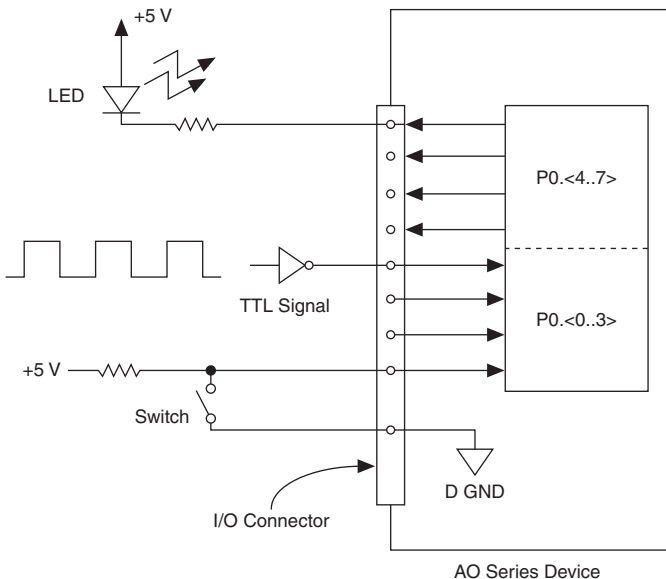



Caution Exceeding the maximum input voltage ratings, which are listed in the specifications of each AO Series device, can damage the DAQ device and the computer. NI is *not* liable for any damage resulting from such signal connections.

Getting Started with DIO Applications in Software

You can use the AO Series device in the following digital I/O applications.

- Static Digital Input
- Static Digital Output
- Digital Waveform Generation
- Digital Waveform Acquisition

(NI 6731/6733 only) For correlated DIO examples in Traditional NI-DAQ (Legacy), refer to the KnowledgeBase document, *What Devices Other Than M Series Can Perform Correlated Digital I/O?*. To access this document, go to ni.com/info and enter the Info Code `rdwd7m`.



Note For more information about programming digital I/O applications and triggers in software, refer to the *NI-DAQmx Help*.

Counters

Figure 5-1 shows a counter on the AO Series device.

Figure 5-1. Counter Block Diagram

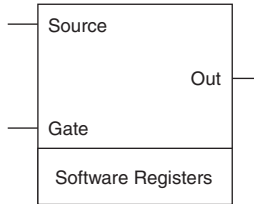

Counters 0 and 1 each have two inputs (source and gate), one output, and two software registers, which are used to perform different operations. Counter functionality is built into the DAQ-STC. For more information on the DAQ-STC, refer to the [DAQ-STC](#) section of Chapter 1, [DAQ System Overview](#).

Counter Triggering

Counters support two different triggering actions: start and pause. Only digital triggers can initiate these actions. For more information on digital triggers, refer to the [Triggering with a Digital Source](#) section of Chapter 10, [Triggering](#).

Start Trigger

A start trigger begins a finite or continuous pulse generation. When a continuous generation is initiated, the pulses continue to generate until you stop the operation in software. The specified number of pulses are generated for finite generations unless the retriggerable attribute is used. The retriggerable attribute causes the generation to restart on a subsequent start trigger.

Pause Trigger

You can use pause triggers in edge counting and continuous pulse generation applications. For edge counting acquisitions, the counter stops counting edges while the external trigger signal is low and resumes when the signal goes high or vice versa. For continuous pulse generations, the counter stops generating pulses while the external trigger signal is low and resumes when the signal goes high or vice versa.

Counter Timing Signals

The following sections contain information on counter timing signals.

Counter Timing Summary

Figure 5-2 shows the timing requirements for the gate and source input signals and the timing specifications for the output signals on your device.

Figure 5-2. Gate and Source Input Timing Requirements

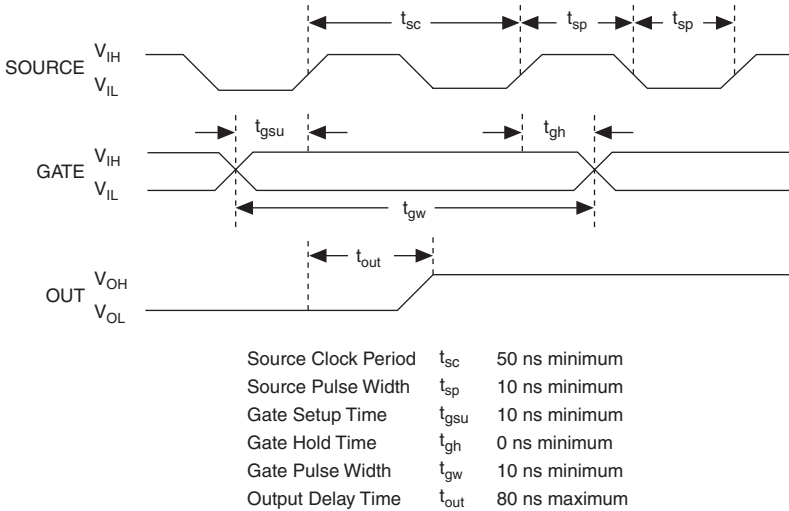

The gate and out signal transitions shown in Figure 5-2 are referenced to the rising edge of the source signal. This timing diagram assumes that the counters are programmed to count rising edges. The same timing diagram, but with the source signal inverted and referenced to the falling edge of the source signal, applies when you program the counter to count falling edges.

The gate input timing parameters are referenced to the signal at the source input or to one of the internally generated signals on your device. Figure 5-2 shows the gate signal referenced to the rising edge of a source signal. The gate must be valid (either high or low) for at least 10 ns before the rising or falling edge of a source signal so the gate can take effect at that source edge, as shown by t_{gsu} and t_{gh} . The gate signal is not required after the active edge of the source signal.

If you use an internal timebase clock, you cannot synchronize the gate signal with the clock. In this case, gates applied close to a source edge take effect either on that source edge or on the next one. This arrangement results in an uncertainty of one source clock period with respect to unsynchronized gating sources.

The output timing parameters are referenced to the signal at the source input or to one of the internally generated clock signals on your device. Figure 5-2 shows the out signal referenced to

the rising edge of a source signal. Any out signal state changes occur within 80 ns after the rising or falling edge of the source signal.

For information on the internal routing available on the DAQ-STC counter/timers, refer to *Counter Parts in NI-DAQmx* in the *NI-DAQmx Help* or the *LabVIEW Help* for more information.

Counter 0 Source Signal

You can select any PFI as well as many other internal signals as the Counter 0 Source (Ctr0Source) signal. The Ctr0Source signal is configured in edge-detection mode on either the rising or falling edge. The selected edge of the Ctr0Source signal increments and decrements the counter value depending on the application the counter is performing.

You can export the Ctr0Source signal to the PFI 8/CTR 0 SOURCE pin, even if another PFI is inputting the Ctr0Source signal. This output is set to high-impedance at startup.

Figure 5-3 shows the timing requirements for the Ctr0Source signal.

Figure 5-3. Ctr0Source Timing Requirements

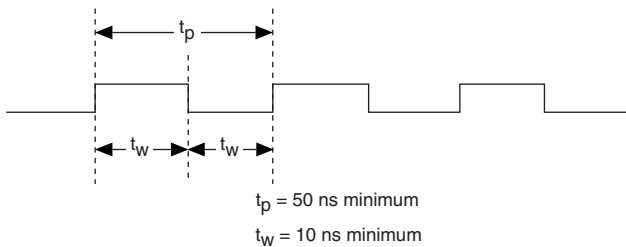

The maximum allowed frequency is 20 MHz, with a minimum pulse width of 10 ns high or low. There is no minimum frequency.

For most applications, unless you select an external source, the 20MHzTimebase signal or the 100kHzTimebase signal generates the Ctr0Source signal.

Counter 0 Gate Signal

You can select any PFI as well as many other internal signals like the Counter 0 Gate (Ctr0Gate) signal. The Ctr0Gate signal is configured in edge-detection or level-detection mode depending on the application performed by the counter. The gate signal can perform many different operations including starting and stopping the counter, generating interrupts, and saving the counter contents.

You can export the gate signal connected to Counter 0 to the PFI 9/CTR 0 GATE pin, even if another PFI is inputting the Ctr0Gate signal. This output is set to high-impedance at startup.

Figure 5-4 shows the timing requirements for the Ctr0Gate signal.

Figure 5-4. Ctr0Gate Timing Requirements

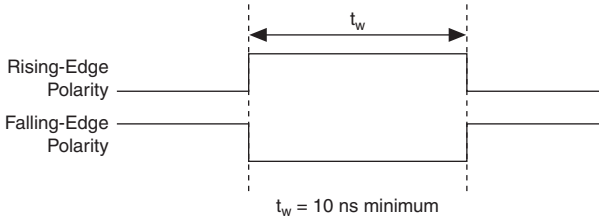

Counter 0 Internal Output Signal

The Counter 0 Internal Output (Ctr0InternalOutput) signal is the output of Counter 0. This signal reflects the terminal count (TC) of Counter 0. The counter generates a terminal count when its count value rolls over. The two software-selectable output options are pulse on TC and toggle output polarity on TC. The output polarity is software-selectable for both options. Figure 5-5 shows the behavior of the Ctr0InternalOutput signal.

Figure 5-5. Ctr0InternalOutput Signal Behavior

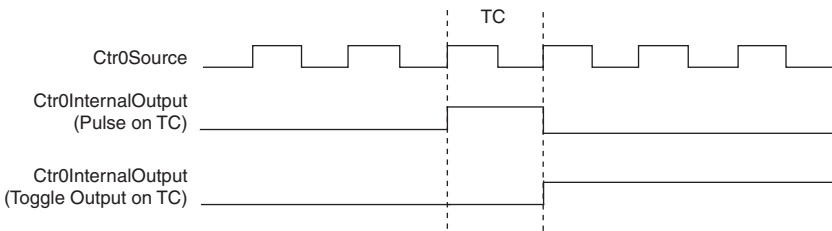

You can use Ctr0InternalOutput in the following applications:

- In pulse generation mode, the counter drives Ctr0InternalOutput with the generated pulses. To enable this behavior, software configures the counter to toggle Ctr0InternalOutput on TC.
- Counter 0 and 1 can be daisy-chained together by routing Ctr0InternalOutput to Ctr1Gate.
- Ctr0InternalOutput can drive any of the RTSI <0..6> signals to control the behavior of other devices in the system.
- Ctr0InternalOutput drives the CTR 0 OUT pin to trigger or control external devices.
- Ctr0InternalOutput can drive other internal signals.

Refer to *Device Routing in MAX* in the *NI-DAQmx Help* or the *LabVIEW Help* for more information.

CTR 0 OUT Pin

When the CTR 0 OUT pin is an output, the Ctr0InternalOutput signal drives the pin. As an input, CTR 0 OUT can drive any of the RTSI <0..6> signals. CTR 0 OUT is set to high-impedance at startup. Figure 5-6 shows the relationship of CTR 0 OUT and Ctr0InternalOutput.

Figure 5-6. CTR 0 OUT and Ctr0InternalOutput

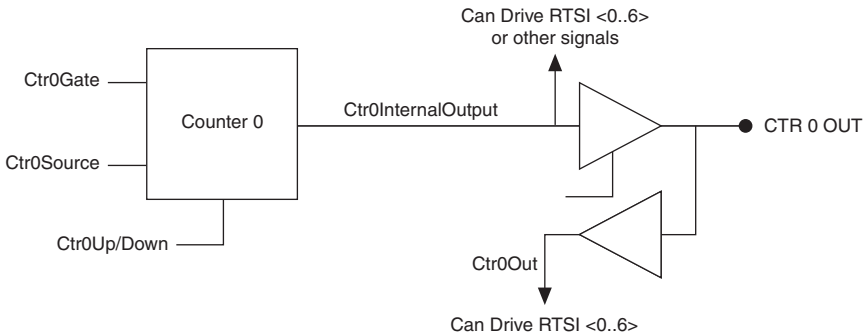

Counter 0 Up/Down Signal

You can externally input this signal on the P0.6 pin, but it is not available as an output on the I/O connector. When you enable externally controlled count direction, Counter 0 counts down when this pin is at a logic low and counts up when it is at a logic high. If you are using an external signal to control the count direction, do not use the P0.6 pin for output. If you do not enable externally controlled count direction, the P0.6 pin is free for general use.

Counter 1 Source Signal

You can select any PFI as well as many other internal signals as the Counter 1 Source (Ctr1Source) signal. The Ctr1Source signal is configured in edge-detection mode on either rising or falling edge. The selected edge of the Ctr1Source signal increments and decrements the counter value depending on the application the counter is performing.

You can export the Counter 1 signal to the PFI 3/CTR 1 SOURCE pin, even if another PFI is inputting the Ctr1Source signal. This output is set to high-impedance at startup.

Figure 5-7 shows the timing requirements for the Ctr1Source signal.

Figure 5-7. Ctr1Source Timing Requirements

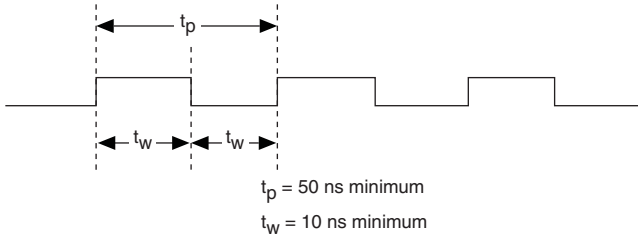

The maximum allowed frequency is 20 MHz, with a minimum pulse width of 10 ns high or low. There is no minimum frequency.

For most applications, unless you select an external source, the 20MHzTimebase signal or the 100kHzTimebase signal generates the Ctr1Source signal.

Counter 1 Gate Signal

You can select any PFI as well as many other internal signals like the Counter 1 Gate (Ctr1Gate) signal. The Ctr1Gate signal is configured in edge-detection or level-detection mode depending on the application performed by the counter. The gate signal can perform many different operations including starting and stopping the counter, generating interrupts, and saving the counter contents.

You can export the gate signal connected to Counter 1 to the PFI 4/CTR 1 GATE pin, even if another PFI is inputting the Ctr1Gate signal. This output is set to high-impedance at startup.

Figure 5-8 shows the timing requirements for the Ctr1Gate signal.

Figure 5-8. Ctr1Gate Timing Requirements

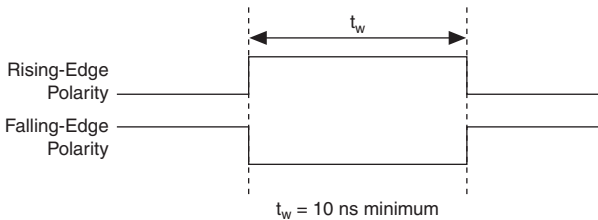

Counter 1 Internal Output Signal

The Counter 1 Internal Output (Ctr1InternalOutput) signal is the output of Counter 1. This signal reflects the terminal count (TC) of Counter 1. The counter generates a terminal count when its count value rolls over. The two software-selectable output options are pulse on TC and toggle output polarity on TC. The output polarity is software-selectable for both options. Figure 5-9 shows the behavior of the Ctr1InternalOutput signal.

Figure 5-9. Ctr1InternalOutput Behavior

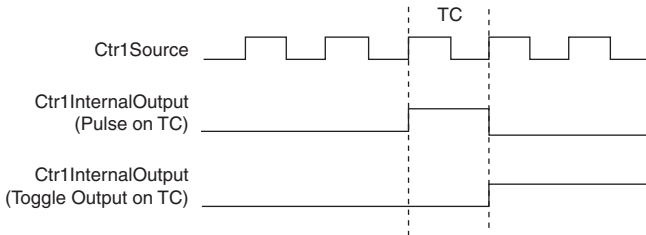

You can use Ctr1InternalOutput in the following applications:

- In pulse generation mode, the counter drives Ctr1InternalOutput with the generated pulses. To enable this behavior, software configures the counter to toggle Ctr1InternalOutput on TC.
- Ctr1InternalOutput can control the timing of analog output acquisitions by driving ao/SampleClock.
- Counter 0 and 1 can be daisy-chained together by routing Ctr1InternalOutput to Ctr0Gate.
- Ctr1InternalOutput drives the CTR 1 OUT pin to trigger or control external devices.
- Ctr1InternalOutput can drive other internal signals.

Refer to *Device Routing in MAX* in the *NI-DAQmx Help* or the *LabVIEW Help* for more information.

Counter 1 Up/Down Signal

You can externally input this signal on the P0.7 pin, but it is not available as an output on the I/O connector. When you enable externally controlled count direction, Counter 1 counts down when this pin is at a logic low and counts up when it is at a logic high. If you do not enable externally controlled count direction, the P0.7 pin is free for general use.

Frequency Output Signal

This signal is available only as an output on the FREQ OUT pin. The frequency generator for your device outputs on the Frequency Output signal. The frequency generator is a four-bit counter that can divide its input clock by the numbers one through 16. The input clock of the frequency generator is software-selectable from the internal 10 MHz and 100 kHz timebases. The output polarity is software-selectable. This output is set to high-impedance at startup.

Master Timebase Signal

The Master Timebase (MasterTimebase) signal, or Onboard Clock, is the timebase from which all other internally generated clocks and timebases on the board are derived. It controls the timing for the analog output and counter subsystems. It is available as an output on the I/O connector, but you must use one or more counters to do so.

The maximum allowed frequency for the MasterTimebase is 20 MHz, with a minimum pulse width of 23 ns high or low. There is no minimum frequency limitation.

The two possible sources for the MasterTimebase signal are the internal 20MHzTimebase signal or an external signal through RTSI 7. Typically the 20MHzTimebase signal is used as the MasterTimebase unless you wish to synchronize multiple devices, in which case, you should use RTSI 7. Refer to Chapter 8, *Real-Time System Integration Bus (RTSI)*, for more information on which signals are available through RTSI.

Figure 5-10 shows the timing requirements for MasterTimebase.

Figure 5-10. MasterTimebase Timing Requirements

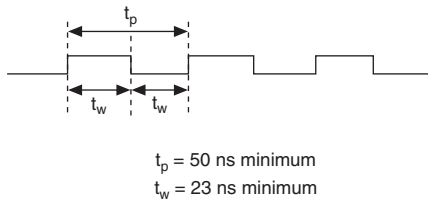

Getting Started with Counter Applications in Software

You can use the AO Series device in the following counter-based applications.

- Counting Edges
- Frequency Measurement
- Period Measurement
- Pulse Width Measurement
- Semi-Period Measurement
- Pulse Generation

You can perform these measurements through programmed I/O, interrupt, or DMA data transfer mechanisms. The measurements can be finite or continuous in duration. Some of the applications also use start triggers and pause triggers.



Note For more information about programming counter applications and triggers in software, refer to the *NI-DAQmx Help*.

Programmable Function Interfaces (PFI)

The 10 Programmable Function Interface (PFI) pins allow timing signals to be routed to and from the I/O connector of a device.

Inputs

An external timing signal can be input on any PFI pin and multiple timing signals can simultaneously use the same PFI pin. This flexible routing scheme reduces the need to change the physical connections to the I/O connector for different applications. For more information, refer to the *Timing Signal Routing* section of Chapter 7, *Digital Routing*.

When using the PFI pin as an input, you can individually configure each PFI for edge or level detection and for polarity selection. You can use the polarity selection for any of the timing signals, but the edge or level detection depends upon the particular timing signal being controlled. The detection requirements for each timing signal are listed within the section that discusses that signal.

In edge-detection mode, the minimum pulse width required is 10 ns. This applies for both rising-edge and falling-edge polarity settings. There is no maximum pulse width requirement in edge-detect mode.

In level-detection mode, there are no minimum or maximum pulse width requirements imposed by the PFI signals, but there can be limits imposed by the particular timing signal being controlled.

Outputs

You can also individually enable each PFI pin to output a specific internal timing signal. For example, if you need the Counter 0 Source signal as an output on the I/O connector, software can turn on the output driver for the PFI 8/CTR 0 SRC pin. This signal, however, cannot be output on any other PFI pin.

Not all timing signals can be output. PFI pins are labeled with the timing signal that can be output on it. For example, PFI 8 is labeled PFI 8/CTR 0 Source. The following timing signals can be output on PFI pins.

- AO Start Trigger Signal
- AO Sample Clock Signal
- Counter 0 Source Signal
- Counter 0 Gate Signal
- Counter 1 Source Signal
- Counter 1 Gate Signal



Caution Do not drive a PFI signal externally when it is configured as an output.

For more information about PFI lines, refer to the *Power-On States* section of Chapter 4, *Digital I/O*. For a list of the PFI pins and the signals they can output, refer to the *I/O Connector Signal Descriptions* section in Chapter 2, *I/O Connector*.

Digital Routing

The digital routing circuitry manages the flow of data between the bus interface and the acquisition subsystems (AO circuitry, digital I/O, and the counters). The digital routing circuitry uses FIFOs (if present) in each subsystem to ensure efficient data movement.

The digital routing circuitry also routes timing and control signals. The acquisition subsystems use these signals to manage acquisitions. These signals can come from:

- your AO Series device
- other devices in your system by way of RTSI
- user input by way of the PFI pins

For a detailed description of which routes are possible on your device, click the **Device Routes** tab in *Measurement & Automation Explorer*.

Timing Signal Routing

The DAQ-STC provides a flexible interface for connecting timing signals to other devices or external circuitry. Your device uses the RTSI bus to interconnect timing signals between devices, and it uses the programmable function interface (PFI) pins on the I/O connector to connect the device to external circuitry. These connections are designed to enable your device to both control and be controlled by other devices and circuits.

You can control the following timing signals internal to the DAQ-STC by an external source.

- AO Start Trigger Signal
- AO Pause Trigger Signal
- AO Sample Clock Signal
- AO Sample Clock Timebase Signal
- DI Sample Clock Signal
- DO Sample Clock Signal
- Counter 0 Source Signal
- Counter 0 Gate Signal
- Counter 0 Up/Down Signal
- Counter 1 Source Signal

- Counter 1 Gate Signal
- Counter 1 Up/Down Signal
- Master Timebase Signal

You also can control these timing signals with signals generated internally to the DAQ-STC, and these selections are fully software-configurable. For example, the signal routing multiplexer for controlling the ao/SampleClock signal is shown in Figure 7-1.

Figure 7-1. Signal Routing Multiplexer on Analog Output Devices

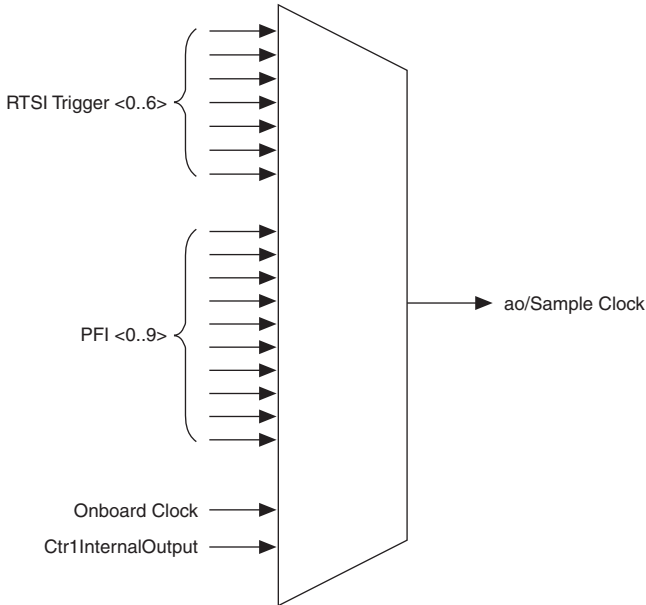

Figure 7-1 shows that you can generate the ao/SampleClock signal from a number of sources, including the external signals RTSI <0..6>, PFI <0..9>, and the internal signals, Onboard Clock, and Ctr1InternalOutput. Here, the Onboard Clock is derived by dividing down the ao/SampleClockTimebase signal.

Many of these timing signals are also available as outputs on the PFI pins.



Note The Master Timebase signal can only be accepted as an external signal over RTSI. For more information on the Master Timebase signal, refer to the *Master Timebase Signal* section of Chapter 5, *Counters*. Refer to the *Device and RTSI Clocks* section of Chapter 8, *Real-Time System Integration Bus (RTSI)*, for information on routing this signal.

Connecting Timing Signals



Caution Exceeding the maximum input voltage ratings listed in the specifications for your device can damage your device and the computer. NI is *not* liable for any damage resulting from signal connections that exceed the maximum ratings.

The 10 programmable function interface (PFI) pins labeled PFI <0..9> route all external control over the timing of the device. These lines serve as connections to virtually all internal timing signals. These PFIs are bidirectional. As outputs they are not programmable and reflect the state of many waveform generation and counter timing signals. There are five other dedicated outputs for the remainder of the timing signals. As inputs, the PFI signals are programmable and can control all timing signals.

All digital timing connections are referenced to D GND. Figure 7-2 shows this reference, and how to connect an external PFI 0 source and an external PFI 2 source to two PFI pins.

Figure 7-2. Connecting PFI 0 and PFI 2 to Two PFI Pins

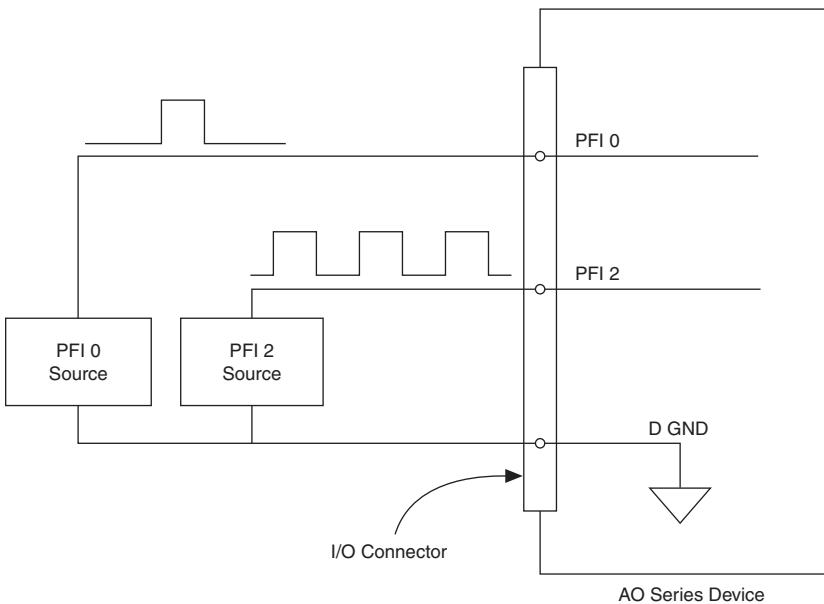

Routing Signals in Software

Table 7-1 lists the basic functions you can use to route signals.

Table 7-1. Signal Routing in Software

Language	Function
LabVIEW	DAQmx Export Signal.vi and DAQmx Connect Terminals.vi
C	Export_Signal and DAQmx_Connect_Terminals



Note For more information about routing signals in software, refer to the *NI-DAQmx Help*.

Real-Time System Integration Bus (RTSI)

NI-DAQ devices use the Real-Time System Integration (RTSI) bus to easily synchronize several measurement functions to a common trigger or timing event. In a PCI system, the RTSI bus consists of the RTSI bus interface and a ribbon cable. The bus can route timing and trigger signals between several functions on as many as five DAQ devices in the computer. In a PXI system, the RTSI bus consists of the RTSI bus interface and the PXI trigger signals on the PXI backplane. This bus can route timing and trigger signals between several functions on as many as seven DAQ devices in the system. Refer to the KnowledgeBase document, *RTSI Connector Pinout*, for more information. To access this document, go to ni.com/info and enter the Info Code `rdrtcp`.



Note The NI DAQCard-6715 does not use the RTSI bus.

RTSI Triggers

The seven RTSI trigger lines on the RTSI bus provide a flexible interconnection scheme for devices sharing the RTSI bus. These bidirectional lines can drive or receive any of the timing and triggering signals shown below directly to or from the trigger bus.

The RTSI trigger lines on PXI devices connect to other devices through the PXI bus on the PXI backplane. RTSI <0..5> connect to PXI Trigger <0..5>, respectively. The RTSI Clock is connected to PXI Trigger 7. In PXI, RTSI 6 connects to the PXI star trigger line, allowing the device to receive triggers from any star trigger controller plugged into Slot 2 of the chassis. AO Series devices can accept timing signals from the PXI star trigger line, but they cannot drive signals onto it. For more information on the star trigger, refer to the *PXI Hardware Specification Revision 2.1*.

Figure 8-1 shows the PCI RTSI bus signal connection.

Figure 8-1. PCI RTSI Bus Signal Connection

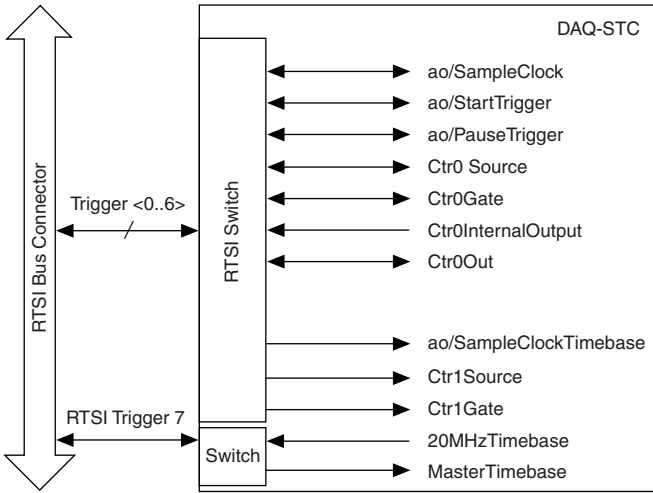
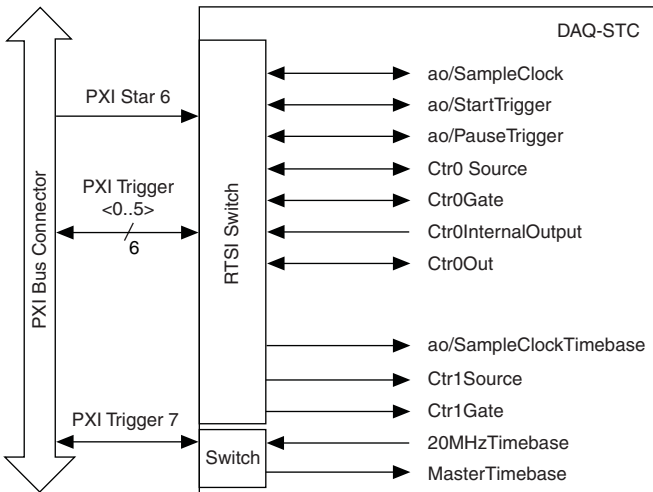

Figure 8-2 shows the PXI RTSI bus signal connection.

Figure 8-2. PXI RTSI Bus Signal Connection



Refer to the *Timing Signal Routing* section of Chapter 7, *Digital Routing*, for a description of the signals shown in Figure 8-1 and Figure 8-2.



Note In NI-DAQmx, some additional timing signals not shown in the figures can be routed to RTSI indirectly. Click the **Device Routes** tab in *Measurement & Automation Explorer* for more information.

Device and RTSI Clocks

Many AO Series device functions require a frequency timebase to generate the necessary timing signals for controlling DAC updates or general-purpose signals at the I/O connector. This timebase is also called the Master Timebase or Onboard Clock. For more information, refer to the *Master Timebase Signal* section of Chapter 3, *Analog Output*.

The AO Series device can use either its internal 20MHzTimebase signal or a timebase received over the RTSI bus. The timebase can only be routed to or received from RTSI 7, or the RTSI clock. The device uses this clock source, whether local or from the RTSI bus, as the primary frequency source. If you configure the device to use the internal timebase, you also can program the device to drive its internal timebase over the RTSI bus to another device that is programmed to receive this timebase signal. The default configuration is to use the internal 20MHzTimebase signal without driving the timebase onto the RTSI bus.

(NI DAQCard-6715 only) The NI DAQCard-6715 does not interface to the RTSI bus. It can only directly use its own internal 20 MHz timebase as the primary frequency source.

Synchronizing Multiple Devices

With the RTSI bus and the routing capabilities of the DAQ-STC, there are several ways to synchronize multiple devices depending on your application. NI recommends that you use a common timebase as the MasterTimebase signal and share any common triggers in the application. One device is designated as the master device and all other devices are designated as slave devices.

The 20MHzTimebase on the master device is the MasterTimebase signal for all devices. The slave devices pull this signal from the master device across the RTSI trigger 7 line. Slave devices also pull any shared triggers across an available RTSI trigger line from the master device. When you start all of the slave devices before starting the master device, you have successfully synchronized your application across multiple devices.

Bus Interface

Each AO Series device is designed on a complete hardware architecture that is deployed on either the PCI or PXI platform. Using NI-DAQ driver software, you have the flexibility to change hardware platforms and operating systems with little or no change to software code.

MITE and DAQ-PnP

PCI and PXI AO Series devices use the MITE application-specific integrated circuit (ASIC) as a bus master interface to the PCI bus. PCI and PXI AO Series devices are inherently Plug-and-Play (PnP) compatible. On all devices, the operating system automatically assigns the base address of the device.

Using PXI with CompactPCI

Using PXI-compatible products with standard CompactPCI products is an important feature provided by *PXI Hardware Specification Revision 2.1*. If you use a PXI-compatible plug-in module in a standard CompactPCI chassis, you cannot use PXI-specific functions, but you can still use the basic plug-in device functions. For example, the RTSI bus on a PXI AO Series device is available in a PXI chassis, but not in a CompactPCI chassis.

The CompactPCI specification permits vendors to develop sub-buses that coexist with the basic PCI interface on the CompactPCI bus. Compatible operation is not guaranteed between CompactPCI devices with different sub-buses nor between CompactPCI devices with sub-buses and PXI. The standard implementation for CompactPCI does not include these sub-buses. The PXI AO Series device works in any standard CompactPCI chassis adhering to the *PICMG CompactPCI 2.0 R3.0* core specification.

PXI-specific features are implemented on the J2 connector of the CompactPCI bus. The PXI device is compatible with any CompactPCI chassis with a sub-bus that does not drive the lines used by that device. Even if the sub-bus is capable of driving these lines, the PXI device is still compatible as long as those pins on the sub-bus are disabled by default and never enabled.



Caution Damage can result if these lines are driven by the sub-bus. NI is *not* liable for any damage resulting from improper signal connections.

Data Transfer Methods

There are three primary ways to transfer data across the PCI bus: Direct Memory Access (DMA), Interrupt Request (IRQ), and Programmed I/O.

Direct Memory Access (DMA)

DMA is a method to transfer data between the device and computer memory without the involvement of the CPU. This method makes DMA the fastest available data transfer method. National Instruments uses DMA hardware and software technology to achieve high throughput rates and to increase system utilization. DMA is the default method of data transfer for DAQ devices that support it.

Interrupt Request (IRQ)

IRQ transfers rely on the CPU to service data transfer requests. The device notifies the CPU when it is ready to transfer data. The data transfer speed is tightly coupled to the rate at which the CPU can service the interrupt requests. If you are using interrupts to acquire data at a rate faster than the rate the CPU can service the interrupts, your systems may start to freeze.

Programmed I/O

Programmed I/O is a data transfer mechanism where the user's program is responsible for transferring data. Each read or write call in the program initiates the transfer of data. Programmed I/O is typically used in software-timed (on demand) operations.

Changing Data Transfer Methods between DMA and IRQ

There are a limited number of DMA channels per device (refer to the specifications document for your device). Each operation (such as AI, DIO, and so on) that requires a DMA channel uses that method until all of the DMA channels are used. When all of the DMA channels are used, you will get an error if you try to run another operation requesting a DMA channel. If appropriate, you can change one of the operations to use interrupts. For NI-DAQmx, use the **Data Transfer Mechanism** property node. For Traditional NI-DAQ (Legacy), use the **Set DAQ Device Information VI** or function.

Triggering

A trigger is a signal that causes a device to perform an action, such as starting an acquisition. You can program your DAQ device to generate triggers on:

- a software command
- a condition on an external digital signal

You can also program your DAQ device to perform an action in response to a trigger. The action can affect:

- analog output generation
- counter behavior

For more information, refer to the *Analog Output Triggering* section of Chapter 3, *Analog Output*, and the *Counter Triggering* section of Chapter 5, *Counters*.

Triggering with a Digital Source

Your DAQ device can generate a trigger on a digital signal. You must specify a source and an edge. The digital source can be any of the PFI or RTSI <0..6> signals.

The edge can be either the rising edge or falling edge of the digital signal. A rising edge is a transition from a low logic level to a high logic level. A falling edge is a high to low transition.

Figure 10-1 shows a falling-edge trigger.

Figure 10-1. Falling-Edge Trigger

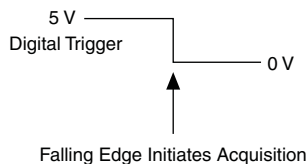

You can also program your DAQ device to perform an action in response to a trigger from a digital source. The action can affect:

- analog output generation
- counter behavior

For more information, refer to the *Analog Output Triggering* section of Chapter 3, *Analog Output*, and the *Counter Triggering* section of Chapter 5, *Counters*.

Device-Specific Information

This appendix includes device-specific information about the following analog output devices:

- NI 6711/6713
- NI DAQCard-6715
- NI 6722/6723
- NI 6731/6733

NI 6711/6713

The following sections contain more information on the NI 6711/6713.

Features (NI 6711/6713)

The NI 6711/6713 are Plug-and-Play, analog output (AO), digital I/O (DIO), and timing I/O (TIO) devices for PCI bus computers. The NI 6711 features:

- four AO channels with 12-bit resolution
- eight lines of TTL-compatible DIO
- two 24-bit counter/timers for TIO
- a 68-pin AO I/O connector

The NI 6713 features:

- eight AO channels with 12-bit resolution
- eight lines of TTL-compatible DIO
- two 24-bit counter/timers for TIO
- a 68-pin AO I/O connector

Because the NI 6711/6713 have no DIP switches, jumpers, or potentiometers, they are easily software-configured and calibrated.

For the NI 6711/6713 connector pinouts, refer to Chapter 2, [I/O Connector](#).

Analog Output (NI 6711/6713)

The NI 6711 has four channels of voltage output at the I/O connector, and the NI 6713 has eight channels of voltage output at the I/O connector. The reference for the AO circuitry is software-selectable per channel. The reference can be either internal or external, but the range is

always bipolar. This means that you can generate signals up to ± 10 V with internal reference selected or $\pm \text{EXT REF}$ voltage with external reference selected.

Block Diagram (NI 6711/6713)

Figure A-1 shows a block diagram of the NI 6711/6713.

Figure A-1. NI 6711/6713 Block Diagram

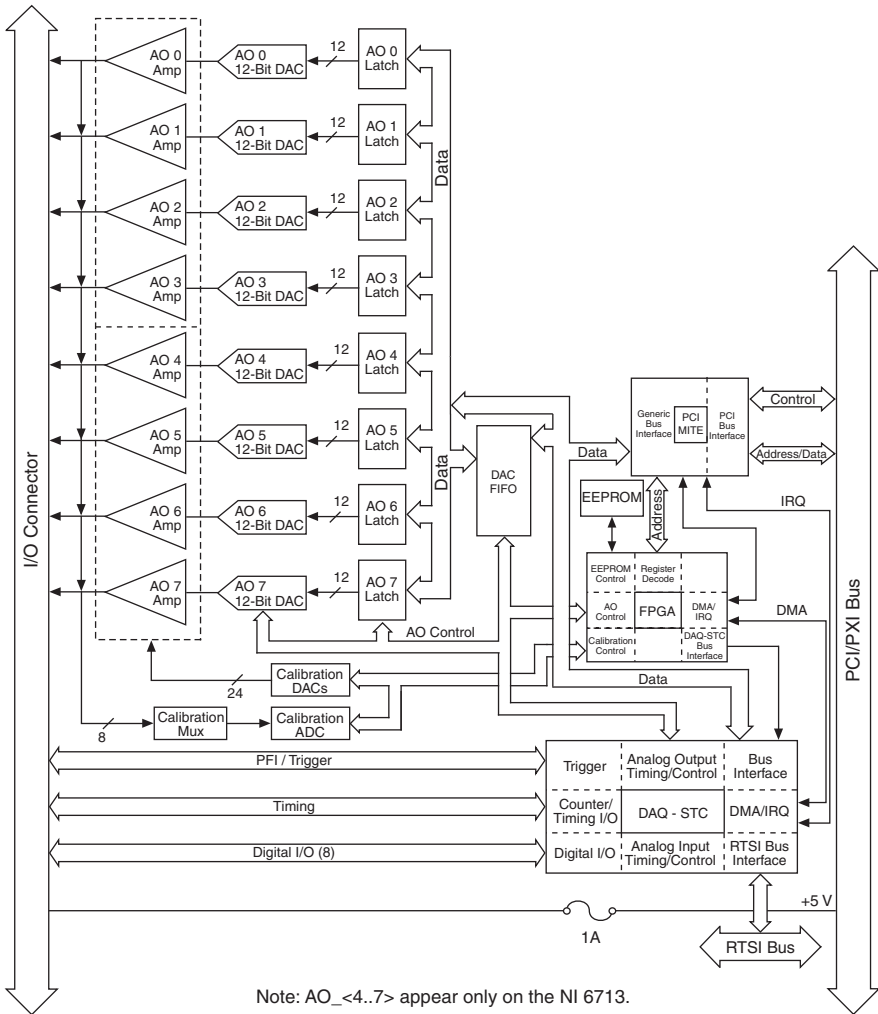

NI DAQCard-6715

The following sections contain more information on the NI DAQCard-6715.

Features (NI DAQCard-6715)

The NI DAQCard-6715 is a Plug-and-Play, analog output (AO), digital I/O (DIO), and timing I/O (TIO) device for PCMCIA bus computers. The NI DAQCard-6715 features:

- eight AO channels with 12-bit resolution
- eight lines of TTL-compatible DIO
- two 24-bit counter/timers for TIO
- a 68-pin AO I/O connector

Because the NI DAQCard-6715 have no DIP switches, jumpers, or potentiometers, they are easily software-configured and calibrated.

For the NI DAQCard-6715 connector pinouts, refer to Chapter 2, *I/O Connector*.

Analog Output (NI DAQCard-6715)

The NI DAQCard-6715 has eight channels of voltage output at the I/O connector. The reference for the AO circuitry is software-selectable per channel. The reference can be either internal or external, but the range is always bipolar. This means that you can generate signals up to ± 10 V with internal reference selected or $\pm \text{EXT REF}$ voltage with external reference selected.

Block Diagram (NI DAQCard-6715)

Figure A-2 shows a block diagram of the NI DAQCard-6715.

Figure A-2. NI DAQCard-6715 Block Diagram

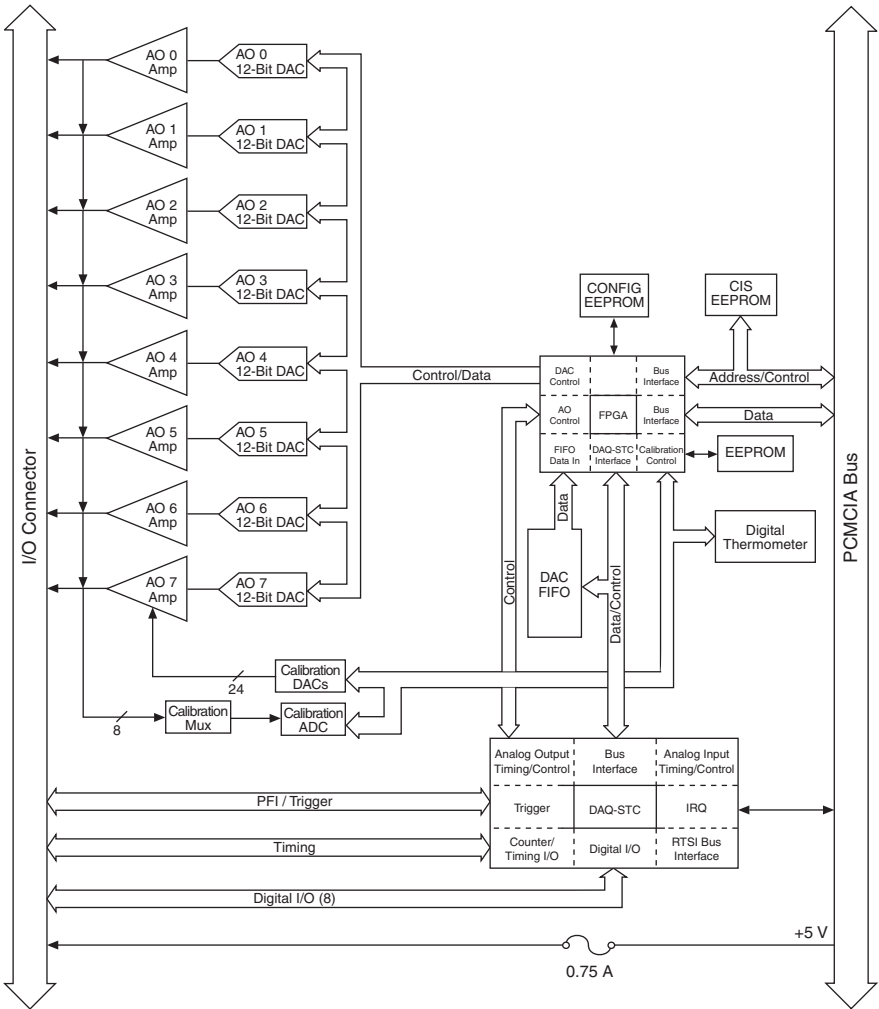

NI 6722/6723

The following sections contain more information on the NI 6722/6723.

Features (NI 6722/6723)

The NI 6722/6723 are Plug-and-Play, analog output (AO), digital I/O (DIO), and timing I/O (TIO) devices for PCI bus computers. The NI 6722 features:

- eight AO channels with 13-bit resolution
- eight lines of TTL-compatible DIO
- two 24-bit counter/timers for TIO
- a 68-pin AO I/O connector

The NI 6723 features:

- 32 AO channels with 13-bit resolution
- eight lines of TTL-compatible DIO
- two 24-bit counter/timers for TIO
- a 68-pin extended AO I/O connector

Because the NI 6722/6723 have no DIP switches, jumpers, or potentiometers, they are easily software-configured and calibrated.

For the NI 6722/6723 connector pinouts, refer to Chapter 2, [I/O Connector](#).

Analog Output (NI 6722/6723)

The NI 6722 has eight channels of voltage output at the I/O connectors, and the NI 6723 has 32 channels of voltage output at the I/O connectors. The reference for the AO circuitry is internal. Each NI 6722/6723 voltage output channel has a bipolar range of ± 10 V from AO GND. You cannot select an external reference to adjust the AO voltage range.

Block Diagram (NI 6722/6723)

Figure A-3 shows a block diagram of the NI 6722/6723.

Figure A-3. NI 6722/6723 Block Diagram

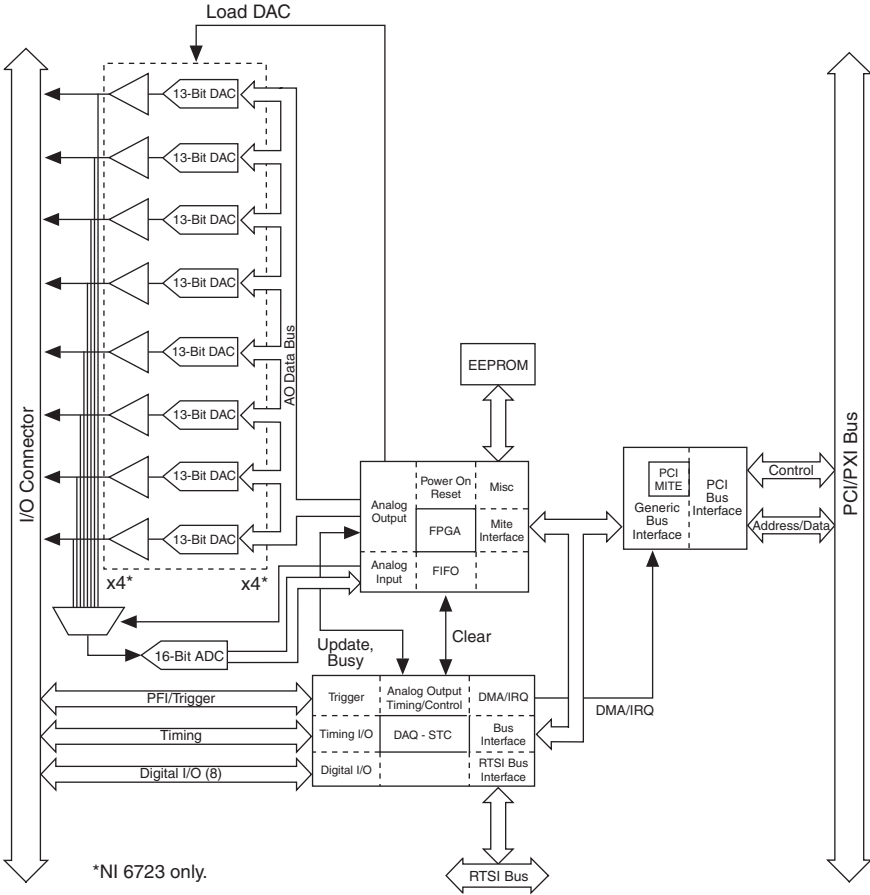

*NI 6723 only.

NI 6731/6733

The following sections contain more information on the NI 6731/6733.

Features (NI 6731/6733)

The NI 6731/6733 are Plug-and-Play, analog output (AO), digital I/O (DIO), and timing I/O (TIO) devices for PCI bus computers. The NI 6731 features:

- four AO channels with 16-bit resolution
- eight lines of TTL-compatible DIO
- two 24-bit counter/timers for TIO
- a 68-pin AO I/O connector

The NI 6733 features:

- eight AO channels with 16-bit resolution
- eight lines of TTL-compatible DIO
- two 24-bit counter/timers for TIO
- a 68-pin AO I/O connector

Because the NI 6731/6733 have no DIP switches, jumpers, or potentiometers, they are easily software-configured and calibrated.

For the NI 6731/6733 connector pinouts, refer to Chapter 2, [I/O Connector](#).

Analog Output (NI 6731/6733)

The NI 6731 has four channels of voltage output at the I/O connector, and the NI 6733 has eight channels of voltage output at the I/O connector. The reference for the AO circuitry is software-selectable per channel. The reference can be either internal or external, but the range is always bipolar. This means that you can generate signals up to ± 10 V with internal reference selected or $\pm \text{EXT REF}$ voltage with external reference selected.

Block Diagram (NI 6731/6733)

Figure A-4 shows a block diagram of the NI 6731/6733.

Figure A-4. NI 6731/6733 Block Diagram

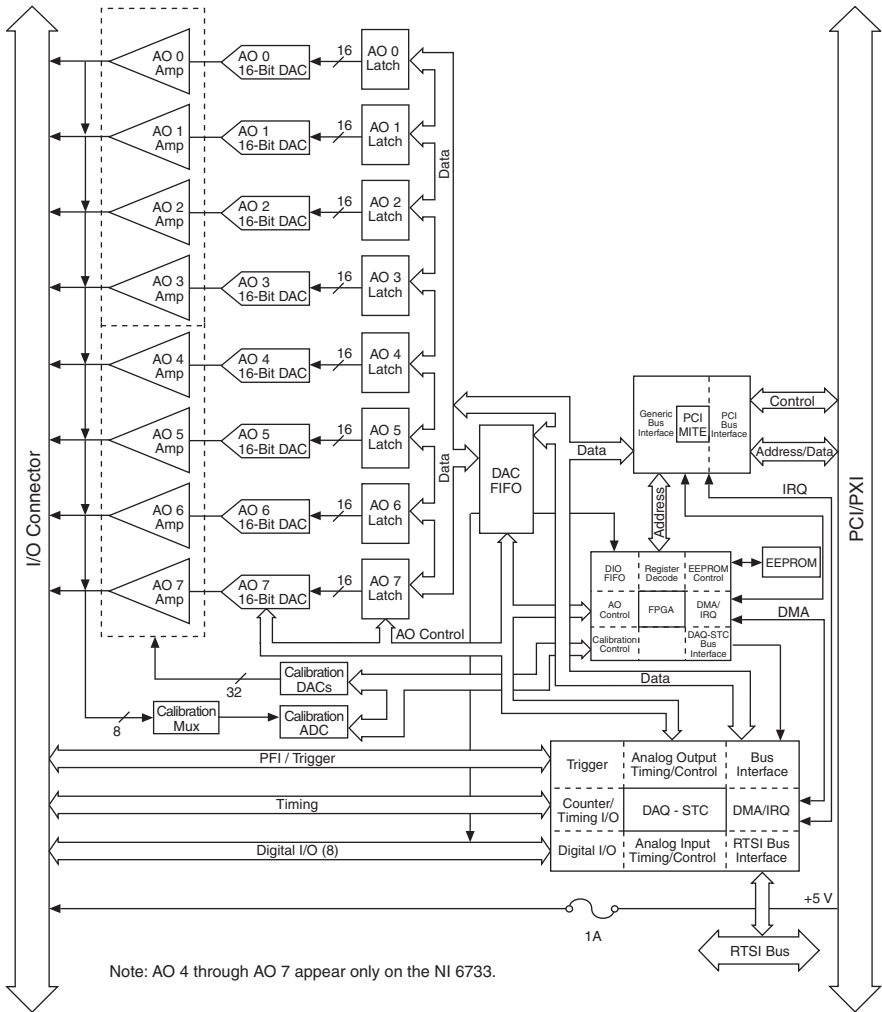

Troubleshooting

This section contains some common questions about AO Series devices. If your questions are not answered here, visit the ni.com/support and search for your model number.

Calculating Frequency Resolution

How can I calculate the frequency resolution of the analog output on the AO Series device?

The analog frequency (f_a) you can generate is determined by the update clock frequency (f_u) and the number of samples per cycle (S_c):

$$f_a = \frac{f_u}{S_c}$$

The onboard 20 MHz clock that generates f_u can only be divided by an integer. For example, suppose you want to generate a sine wave at 2 kHz with 50 samples per cycle. Substitute 2 kHz and 50 samples into the previous equation to get:

$$2 \text{ kHz} = \frac{f_u}{50}$$

So f_u equals 100 kHz. The 20 MHz clock must be divided by 200 as shown by:

$$\frac{20 \text{ MHz}}{200} = 100 \text{ kHz}$$

Suppose now you want to slightly increase or decrease the frequency of the sine wave. The closest available update clock you can generate occurs using a divisor of 199 or 201. If you choose 201, f_u equals 99.5 kHz, as the following equation shows:

$$\frac{20 \text{ MHz}}{201} = 99.50 \text{ kHz}$$

In this case, f_a equals 1.99 kHz, according to the following equation:

$$f_a = \frac{99.50 \text{ kHz}}{50} = 1.99 \text{ kHz}$$

The smallest frequency change that you can generate in this case is approximately 10 Hz.

Power-On States of the Analog Output Lines

I have some motors connected directly into the outputs of my NI 6713, and when I power on my computer they start running very slowly. I am reading an offset of 100 to 110 mV. If I open the test panels in Measurement & Automation Explorer (MAX) or run any LabVIEW application, the outputs drop to 0 V. Why is this happening and how do I prevent it?

The power-on state for the outputs of the NI 6713 is 0 V, with an accuracy of ± 200 mV. When the computer is powered on, the output values might go to 100 to 110 mV, which are within the specifications. When you run LabVIEW or the test panels in MAX, the driver loads the device's calibration constants into the device and the voltage drops to zero.

If there is any hardware connected to the device, the best way to work around this problem is to have an additional output (digital or analog) that will power on the device.

Update Rate

What is update rate?

Update rate is the fastest rate that you can output data from the device and still achieve accurate results. For example, the NI 6723 has an update rate of 800 kS/s on one channel, and 204 kS/s when using all channels. The fastest rate that the output voltage can change is also limited by the device's slew rate.

NI Services

NI provides global services and support as part of our commitment to your success. Take advantage of product services in addition to training and certification programs that meet your needs during each phase of the application life cycle; from planning and development through deployment and ongoing maintenance.

To get started, register your product at ni.com/myproducts.

As a registered NI product user, you are entitled to the following benefits:

- Access to applicable product services.
- Easier product management with an online account.
- Receive critical part notifications, software updates, and service expirations.

Log in to your MyNI user profile to get personalized access to your services.

Services and Resources

- **Maintenance and Hardware Services**—NI helps you identify your systems' accuracy and reliability requirements and provides warranty, sparing, and calibration services to help you maintain accuracy and minimize downtime over the life of your system. Visit ni.com/services for more information.
 - **Warranty and Repair**—All NI hardware features a one-year standard warranty that is extendable up to five years. NI offers repair services performed in a timely manner by highly trained factory technicians using only original parts at an NI service center.
 - **Calibration**—Through regular calibration, you can quantify and improve the measurement performance of an instrument. NI provides state-of-the-art calibration services. If your product supports calibration, you can obtain the calibration certificate for your product at ni.com/calibration.
- **System Integration**—If you have time constraints, limited in-house technical resources, or other project challenges, National Instruments Alliance Partner members can help. To learn more, call your local NI office or visit ni.com/alliance.

- **Training and Certification**—The NI training and certification program is the most effective way to increase application development proficiency and productivity. Visit ni.com/training for more information.
 - The Skills Guide assists you in identifying the proficiency requirements of your current application and gives you options for obtaining those skills consistent with your time and budget constraints and personal learning preferences. Visit ni.com/skills-guide to see these custom paths.
 - NI offers courses in several languages and formats including instructor-led classes at facilities worldwide, courses on-site at your facility, and online courses to serve your individual needs.
- **Technical Support**—Support at ni.com/support includes the following resources:
 - **Self-Help Technical Resources**—Visit ni.com/support for software drivers and updates, a searchable KnowledgeBase, product manuals, step-by-step troubleshooting wizards, thousands of example programs, tutorials, application notes, instrument drivers, and so on. Registered users also receive access to the NI Discussion Forums at ni.com/forums. NI Applications Engineers make sure every question submitted online receives an answer.
 - **Software Support Service Membership**—The Standard Service Program (SSP) is a renewable one-year subscription included with almost every NI software product, including NI Developer Suite. This program entitles members to direct access to NI Applications Engineers through phone and email for one-to-one technical support, as well as exclusive access to online training modules at ni.com/self-paced-training. NI also offers flexible extended contract options that guarantee your SSP benefits are available without interruption for as long as you need them. Visit ni.com/ssp for more information.
- **Declaration of Conformity (DoC)**—A DoC is our claim of compliance with the Council of the European Communities using the manufacturer’s declaration of conformity. This system affords the user protection for electromagnetic compatibility (EMC) and product safety. You can obtain the DoC for your product by visiting ni.com/certification.

For information about other technical support options in your area, visit ni.com/services, or contact your local office at ni.com/contact.

You also can visit the Worldwide Offices section of ni.com/niglobal to access the branch office websites, which provide up-to-date contact information, support phone numbers, email addresses, and current events.

Glossary

Symbol	Prefix	Value
n	nano	10^{-9}
μ	micro	10^{-6}
m	milli	10^{-3}
k	kilo	10^3
M	mega	10^6

Symbols

- Negative of, or minus.

Ω Ohms.

% Percent.

\pm Plus or minus.

+ Positive of, or plus.

A

A Amperes—the unit of electric current.

A/D Analog-to-digital.

AC Alternating current.

ADC Analog-to-digital converter—an electronic device, often an integrated circuit, that converts an analog voltage to a digital number.

AI
1. Analog input
2. Analog input channel signal.

AI HOLD COMP Analog input hold complete signal.

AO Analog output.

Glossary

AO 0	Analog channel 0 output signal.
AO 1	Analog channel 1 output signal.
AO GND	Analog output ground signal.
ASIC	Application-Specific Integrated Circuit—a proprietary semiconductor component designed and manufactured to perform a set of specific functions.
B	
bipolar	A signal range that includes both positive and negative values (for example, -5 to +5 V)
C	
C	Celsius
channel	<ol style="list-style-type: none">1. Physical—a terminal or pin at which you can measure or generate an analog or digital signal. A single physical channel can include more than one terminal, as in the case of a differential analog input channel or a digital port of eight lines. The name used for a counter physical channel is an exception because that physical channel name is not the name of the terminal where the counter measures or generates the digital signal.2. Virtual—a collection of property settings that can include a name, a physical channel, input terminal connections, the type of measurement or generation, and scaling information. You can define NI-DAQmx virtual channels outside a task (global) or inside a task (local). Configuring virtual channels is optional in Traditional NI-DAQ (Legacy) and earlier versions, but is integral to every measurement you take in NI-DAQmx. In Traditional NI-DAQ (Legacy), you configure virtual channels in MAX. In NI-DAQmx, you can configure virtual channels either in MAX or in a program, and you can configure channels as part of a task or separately.
cm	Centimeter.
CMOS	Complementary metal-oxide semiconductor.

correlated DIO	A feature that allows you to clock digital I/O on the same clock as analog I/O.
counter/timer	A circuit that counts external pulses or clock pulses (timing).
D	
D/A	Digital-to-analog.
DAC	Digital-to-analog converter—an electronic device, often an integrated circuit, that converts a digital number into a corresponding analog voltage or current.
DAQ	See data acquisition (DAQ) .
DAQ device	A device that acquires or generates data and can contain multiple channels and conversion devices. DAQ devices include plug-in devices, PCMCIA cards, and DAQPad devices, which connect to a computer USB or 1394 (FireWire®) port. SCXI modules are considered DAQ devices.
DAQ-STC	Data acquisition system timing controller—an application-specific integrated circuit (ASIC) for the system timing requirements of a general A/D and D/A system.
data acquisition (DAQ)	<ol style="list-style-type: none"> 1. Acquiring and measuring analog or digital electrical signals from sensors, transducers, and test probes or fixtures. 2. Generating analog or digital electrical signals.
dB	Decibel—the unit for expressing a logarithmic measure of the ratio of two signal levels: $dB = 20\log_{10} V_1/V_2$ for signals in volts
DC	Direct current—although the term speaks of current, many different types of DC measurements are made, including DC Voltage, DC current, and DC power.
device	<ol style="list-style-type: none"> 1. An instrument or controller you can access as a single entity that controls or monitors real-world I/O points. A device often is connected to a host computer through some type of communication network. 2. See also DAQ device and measurement device.
DIO	Digital input/output.

Glossary

DMA Direct memory access—a method by which data can be transferred to/from computer memory from/to a device or memory on the bus while the processor does something else. DMA is the fastest method of transferring data to/from computer memory.

DNL Differential nonlinearity—a measure in least significant bit of the worst-case deviation of code widths from their ideal value of 1 LSB.

driver Software unique to the device or type of device, and includes the set of commands the device accepts.

E

EEPROM Electrically erasable programmable read-only memory—ROM that can be erased with an electrical signal and reprogrammed.

ESD Electrostatic Discharge—a high-voltage, low-current discharge of static electricity that can damage sensitive electronic components. Electrostatic discharge voltage can easily range from 1,000 V to 10,000 V.

F

FPGA Field-programmable gate array.

H

Hz Hertz.

I

I/O Input/output—the transfer of data to/from a computer system involving communications channels, operator interface devices, and/or data acquisition and control interfaces.

INL Integral nonlinearity—for an ADC, deviation of codes of the actual transfer function from a straight line.

I_{OH} Current, output high.

I_{OL}	Current, output low.
IRQ	Interrupt request.
L	
LED	Light-emitting diode—a semiconductor light source.
LSB	Least significant bit.
M	
m	Meter.
measurement device	DAQ devices such as the E Series multifunction I/O (MIO) devices, SCXI signal conditioning modules, and switch modules.
MSB	Most significant bit.
module	A board assembly and its associated mechanical parts, front panel, optional shields, and so on. A module contains everything required to occupy one or more slots in a mainframe. SCXI and PXI devices are modules.
monotonicity	A characteristic of a DAC in which the analog output always increases as the values of the digital code input to it increase.
N	
NC	Normally closed, or not connected.
NI	National Instruments.
NI-DAQ	Driver software included with all NI measurement devices. NI-DAQ is an extensive library of VIs and functions you can call from an application development environment (ADE), such as LabVIEW, to program all the features of an NI measurement device, such as configuring, acquiring and generating data from, and sending data to the device.

NI-DAQmx The latest NI-DAQ driver with new VIs, functions, and development tools for controlling measurement devices. The advantages of NI-DAQmx over earlier versions of NI-DAQ include the DAQ Assistant for configuring channels and measurement tasks for your device for use in LabVIEW, LabWindows/CVI, and Measurement Studio; increased performance such as faster single-point analog I/O; and a simpler API for creating DAQ applications using fewer functions and VIs than earlier versions of NI-DAQ.

noise An undesirable electrical signal. Noise comes from external sources such as the AC power line, motors, generators, transformers, fluorescent lights, CRT displays, computers, electrical storms, welders, radio transmitters, and internal sources such as semiconductors, resistors, and capacitors. Noise corrupts signals you are trying to send or receive.

NRSE Nonreferenced single-ended mode—all measurements are made with respect to a common (NRSE) measurement system reference, but the voltage at this reference can vary with respect to the measurement system ground.

P

PCI Peripheral Component Interconnect—a high-performance expansion bus architecture originally developed by Intel to replace ISA and EISA. It offers a theoretical maximum transfer rate of 132 Mbytes/s.

pd Pull-down.

PFI Programmable function interface.

PGIA Programmable gain instrumentation amplifier.

physical channel *See* [channel](#).

port

1. A communications connection on a computer or a remote controller.
2. A digital port consisting of four or eight lines of digital input and/or output.

ppm Parts per million.

pu Pull-up.

PXI	PCI eXtensions for Instrumentation—PXI is an open specification that builds off the CompactPCI specification by adding instrumentation-specific features.
R	
rms	Root mean square.
RSE	Referenced single-ended mode—all measurements are made with respect to a common reference measurement system or a ground. Also called a grounded measurement system.
RTSI	Real-Time System Integration—the National Instruments timing bus that connects DAQ devices directly, by means of connectors on top of the devices, for precise synchronization of functions.
S	
s	Seconds.
S	Samples.
S/s	Samples per second—used to express the rate at which a digitizer or D/A converter or DAQ device samples an analog signal.
scan interval	Controls how often a scan is initialized; is regulated by the AI SAMP signal.
scan rate	Reciprocal of the scan interval.
SCXI	Signal Conditioning eXtensions for Instrumentation—the National Instruments product line for conditioning low-level signals within an external chassis near sensors so that only high-level signals are sent to DAQ devices in the noisy PC environment. SCXI is an open standard available for all vendors.
sensor	A device that responds to a physical stimulus (heat, light, sound, pressure, motion, flow, and so on) and produces a corresponding electrical signal.
settling time	The amount of time required for a voltage to reach its final value within specified limits.
signal conditioning	The manipulation of signals to prepare them for digitizing.

T

task	NI-DAQmx—a collection of one or more channels, timing, and triggering and other properties that apply to the task itself. Conceptually, a task represents a measurement or generation you want to perform.
terminal count	The highest value of a counter.
t_{gh}	Gate hold time.
t_{gsu}	Gate setup time.
t_{gw}	Gate pulse width.
t_{out}	Output delay time.
Traditional NI-DAQ (Legacy)	An upgrade to the earlier version of NI-DAQ. Traditional NI-DAQ (Legacy) has the same VIs and functions and works the same way as NI-DAQ 6.9.x. You can use both Traditional NI-DAQ (Legacy) and NI-DAQmx on the same computer, which is not possible with NI-DAQ 6.9.x.
transducer	<i>See</i> sensor .
t_{sc}	Source clock period.
t_{sp}	Source pulse width.
TTL	Transistor-transistor logic—a digital circuit composed of bipolar transistors wired in a certain manner. A typical medium-speed digital technology. Nominal TTL logic levels are 0 and 5 V.

V

V	Volts.
V_{CC}	Nominal +5 V power supply provided by the PC motherboard.
VDC	Volts direct current.

VI, virtual instrument	<ol style="list-style-type: none">1. A combination of hardware and/or software elements, typically used with a PC, that has the functionality of a classic stand-alone instrument.2. A LabVIEW software module (VI), which consists of a front panel user interface and a block diagram program.
V_{IH}	Volts, input high.
V_{IL}	Volts, input low.
V_{in}	Volts in.
V_{OH}	Volts, output high.
V_{OL}	Volts, output low.
V_{rms}	Volts, root mean square.
virtual channel	See channel .

Index

A

- accessories, 1-4
 - devices, 1-5
 - field wiring considerations, 1-7
- analog output
 - circuitry, 3-1
 - connecting analog output signals, 3-5
 - minimizing glitches, 3-3
 - NI 6711/6713, A-1
 - NI 6722/6723, A-5
 - NI 6731/6733, A-7
 - NI DAQCard-6715, A-3
- analog output triggering
 - AO Pause Trigger, 3-6
 - AO Start Trigger, 3-5
- AO applications, 3-10

B

- block diagram
 - NI 6711/6713, A-2
 - NI 6722/6723, A-6
 - NI 6731/6733, A-8
 - NI DAQCard-6715, A-4

C

- cables, 1-4
 - custom, 1-7
 - devices, 1-5
 - field wiring considerations, 1-7
- calculating frequency resolution, B-1
- calibration, 1-4
- correlated DIO
 - DI Sample Clock, 4-4
 - digital waveform acquisition, 4-3
 - digital waveform generation, 4-2
 - DO Sample Clock, 4-2
- counter applications, 5-8
- counter timing signals
 - Counter 0 Gate, 5-3
 - Counter 0 Internal Output, 5-4
 - Counter 0 Source, 5-3
 - Counter 0 Up/Down, 5-5

- Counter 1 Gate, 5-6
- Counter 1 Internal Output, 5-7
- Counter 1 Source, 5-5
- Counter 1 Up/Down, 5-7
- counter timing summary, 5-2
- Frequency Output, 5-7
- Master Timebase, 5-8

D

- DAC FIFO, 3-1
- DACs, 3-1
- DAQ System Overview, 1-1
- DAQCard
 - analog output, A-3
 - block diagram, A-4
 - features, A-3
- DAQ-STC, 1-3
- data transfer methods, changing, 9-2
- device and RTSI clocks, 8-3
- DI Sample Clock, 4-4
- digital I/O
 - connecting digital I/O signals, 4-5
 - power-on state, 4-5
- DIO applications, 4-6
- direct memory access (DMA), 9-2
- DO Sample Clock, 4-2

E

- external reference, 3-5

F

- features
 - NI 6711/6713, A-1
 - NI 6722/6723, A-5
 - NI 6731/6733, A-7
 - NI DAQCard-6715, A-3
- frequency resolution, B-1

G

- glitches on the output signal, minimizing, 3-3

I

I/O connector

- 68-68-pin extended AO, 2-5
- 68-pin AO, 2-1
- NI 6711 (figure), 2-2
- NI 6713 (figure), 2-3
- NI 6722 (figure), 2-4
- NI 6723 (figure), 2-5
- NI 6731 (figure), 2-2
- NI 6733 (figure), 2-3
- NI DAQCard-6715 (figure), 2-3
- signal descriptions, 2-7

I/O protection, 4-4

interrupt request (IRQ), 9-2

interrupts, 9-2

M

minimizing glitches, 3-3

N

NI 6711/6713

- analog output, A-1
- block diagram, A-2
- features, A-1

NI 6722/6723

- analog output, A-5
- block diagram, A-6
- features, A-5

NI 6731/6733

- analog output, A-7
- block diagram, A-8
- features, A-7

NI DAQCard-6715

- analog output, A-3
- block diagram, A-4
- features, A-3

P

PFI, 6-1

pinouts

- 68-68-pin extended AO, 2-5
- 68-pin AO, 2-1

NI 6711 (figure), 2-2

NI 6713 (figure), 2-3

NI 6722 (figure), 2-4

NI 6723 (68-68-pin extended I/O), 2-5

NI 6723 (68-pin AO) (figure), 2-4

NI 6731 (figure), 2-2

NI 6733 (figure), 2-3

NI DAQCard-6715 (figure), 2-3

polarity selection, 3-2

power-on states

AO lines, B-2

PFI and DIO lines, 4-5

programmable function interfaces, 6-1

programmed I/O, 9-2

programming devices, 1-8

R

reference selection, 3-1, 3-2

reglitch selection, 3-2

RTSI, 8-1

S

signal descriptions, 2-7

synchronizing multiple devices, 8-3

T

terminal name equivalents, 2-5

timing signal routing, 7-1

device and RTSI clocks, 8-3

RTSI, 8-1

RTSI triggers, 8-1

timing signals

connecting, 7-3

counter, 5-2

power-on state, 4-5

routing, 7-1

waveform generation, 3-5

triggering

about, 10-1

AO Pause Trigger, 3-6

AO Start Trigger, 3-5

digital source, 10-1

troubleshooting

- calculating frequency resolution, B-1
- power-on states of the analog output lines, B-2
- update rate, B-2

U

- update rate, B-2

W

waveform generation timing signals

- AO Pause Trigger, 3-6
- AO Sample Clock, 3-7
- AO Sample Clock Timebase, 3-9
- AO Start Trigger, 3-5
- Master Timebase, 3-9
- waveform generation timing summary, 3-5