

COMPREHENSIVE SERVICES

We offer competitive repair and calibration services, as well as easily accessible documentation and free downloadable resources.

SELL YOUR SURPLUS

We buy new, used, decommissioned, and surplus parts from every NI series. We work out the best solution to suit your individual needs.

 Sell For Cash  Get Credit  Receive a Trade-In Deal

OBSOLETE NI HARDWARE IN STOCK & READY TO SHIP

We stock **New**, **New Surplus**, **Refurbished**, and **Reconditioned** NI Hardware.



Bridging the gap between the manufacturer and your legacy test system.

 1-800-915-6216

 www.apexwaves.com

 sales@apexwaves.com

All trademarks, brands, and brand names are the property of their respective owners.

Request a Quote

 **CLICK HERE**

TRC-8543

OPERATING INSTRUCTIONS

NI-XNET CAN HS/FD Transceiver Cable

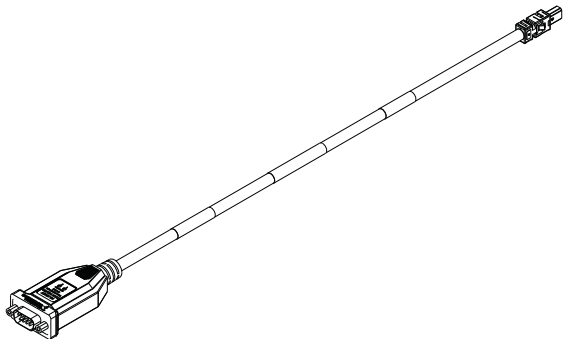

These operating instructions describe how to use the NI-XNET CAN HS/FD Transceiver Cable. For information about installing, configuring, and programming your system, refer to your system documentation. The transceiver cable requires the latest NI-XNET software to be installed. The latest version of the NI-XNET software is at ni.com/downloads.



Note The safety guidelines and specifications in this document are specific to the NI-XNET CAN HS/FD Transceiver Cable. The other components in your system may not meet the same safety ratings and specifications. Refer to the documentation for each component in your system to determine the safety ratings and specifications for the entire system.

Safety Guidelines

Operate the NI-XNET CAN HS/FD Transceiver Cable only as described in these operating instructions.



Hot Surface This icon denotes that the component may be hot. Touching this component may result in bodily injury.



Caution Do not operate the NI-XNET CAN HS/FD Transceiver Cable in a manner not specified in these operating instructions. Product misuse can result in a hazard. You can compromise the safety protection built into the product if the product is damaged in any way. If the product is damaged, return it to National Instruments for repair.

Safety Guidelines for Hazardous Locations

The NI-XNET CAN HS/FD Transceiver Cable is suitable for use in Class I, Division 2, Groups A, B, C, D, T4 hazardous locations; Class I, Zone 2, AEx nA IIC T4 and Ex nA IIC T4 hazardous locations; and nonhazardous locations only. Follow these guidelines if you are installing the NI-XNET CAN HS/FD Transceiver Cable in a potentially explosive environment. Not following these guidelines may result in serious injury or death.



Caution Do *not* disconnect bus-side connector unless power has been switched off or the area is known to be nonhazardous.



Caution Do *not* unplug transceiver cable unless power has been switched off or the area is known to be nonhazardous.



Caution Substitution of components may impair suitability for Class I, Division 2.



Caution For Division 2 and Zone 2 applications, install the system in an enclosure rated to at least IP 54 as defined by IEC 60529 and EN 60529.



Caution For Division 2 and Zone 2 applications, install a protection device between the CAN bus and the NI-XNET CAN HS/FD Transceiver Cable CAN pins. The device must prevent the CAN Port-to-COM voltage from exceeding 55 V if there is a transient overvoltage condition.

Special Conditions for Safe Use in Europe

This equipment has been evaluated as Ex nA IIC T4 equipment under DEMKO Certificate 12 ATEX Number (1202658X). Each transceiver cable is marked  II 3G and is suitable for use in Zone 2 hazardous locations.



Caution You *must* make sure that transient disturbances do not exceed 140% of the rated voltage.



Caution The system shall be mounted in an ATEX certified enclosure with a minimum ingress protection rating of at least IP54 as defined in IEC/EN 60529 and used in an environment of not more than Pollution Degree 2.



Caution The enclosure must have a door or cover accessible only by the use of a tool.

Mounting the NI-XNET CAN HS/FD Transceiver Cable



Caution The NI-XNET CAN HS/FD Transceiver Cable is a thermally active device that dissipates heat.

Refer to the user manual of the host this device directly connects to for specific information regarding thermal management. Not following mounting requirements may affect the system ambient temperature and/or the measurement accuracy of modules in the system.

The Transceiver Cable is intended to be routed and strain relieved similar to other cables, and does not require a special mounting accessory.

Wiring to the NI-XNET CAN HS/FD Transceiver Cable

The NI-XNET CAN HS/FD Transceiver Cable is used with a compatible NI-XNET Transceiver Cable host port.

Figure 1. NI-XNET CAN HS/FD Transceiver Cable Connections

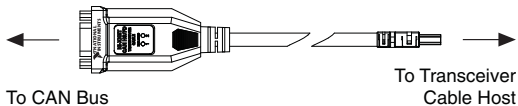

The NI-XNET CAN HS/FD Transceiver Cable has one 9-pin male D-Sub connector that provides connections to a CAN bus. The NI-XNET CAN HS/FD Transceiver Cable has pins for CAN_H and CAN_L, to which you connect the CAN bus signals. Connect these signals using twisted-pair cable.

The port has two common pins (COM) that are internally connected to the transceiver cable's isolated reference and serve as

the reference ground for CAN_H and CAN_L. You can connect the CAN bus reference ground (sometimes referred to as CAN_V) to one or both COM pins.

The D-Sub connector shell connects through the NI-XNET CAN HS/FD Transceiver Cable shielding to the connector on the host port end. The shielding does not electrically connect to the COM signals.

The NI-XNET CAN HS/FD Transceiver Cable gets power from the XNET host port. No external power from the CAN bus is required.



Note The NI-XNET CAN HS/FD Transceiver Cable is internally powered, but LIN and some other cables may require external power when the bus standard requires it.

The NI-XNET CAN HS/FD Transceiver Cable pinout is listed in Table 1.

The NI-XNET CAN HS/FD Transceiver Cable features software-selectable bus termination for High-Speed CAN transceivers. On the NI-XNET CAN HS/FD Transceiver Cable, you can enable 120 Ω termination resistors between CAN_H and

CAN_L through an API call. If you choose to use external termination, Table 3 lists recommended termination resistor values.

Table 1. Pin Assignments for the NI-XNET CAN HS/FD Transceiver Cable

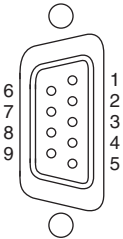
Connector	Pin	Signal
	1	No Connection (NC)
	2	CAN_L
	3	COM
	4	NC
	5	NC
	6	COM
	7	CAN_H
	8	NC
	9	NC

CAN Bus Topology and Termination

A CAN bus consists of two or more CAN nodes cabled together. The CAN_H and CAN_L pins of each node are connected to the main CAN bus cable through a short connection known as a “stub.” The pair of signal wires, CAN_H and CAN_L, constitutes a transmission line. If the transmission line is not terminated, each signal change on the bus causes reflections that may cause communication errors. Because the CAN bus is bidirectional, both ends of the cable must be terminated. However, this requirement does not mean that every node on the bus should have a termination resistor; only the two nodes at the far end of the cable should have termination resistors.

Figure 2 shows a simplified diagram of a CAN bus with multiple CAN nodes and proper termination resistor (R_t) locations.

Figure 2. CAN Bus Topology and Termination Resistor Locations

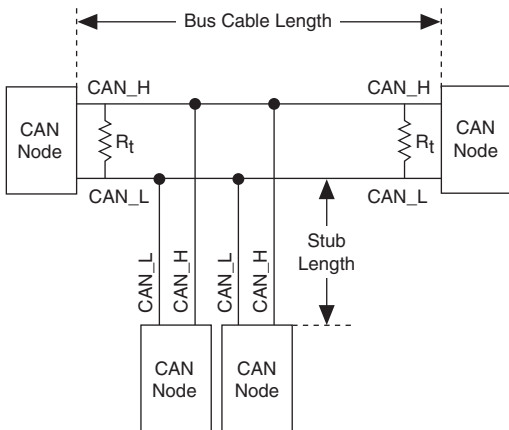

Connecting a CAN Bus to the NI-XNET CAN HS/FD Transceiver Cable

You can connect the NI-XNET CAN HS/FD Transceiver Cable port to any location on a CAN bus. Figure 3 shows one example of connecting the NI-XNET CAN HS/FD Transceiver Cable directly to one CAN node.

Figure 3. Connecting the NI-XNET CAN HS/FD Transceiver Cable to a CAN Device

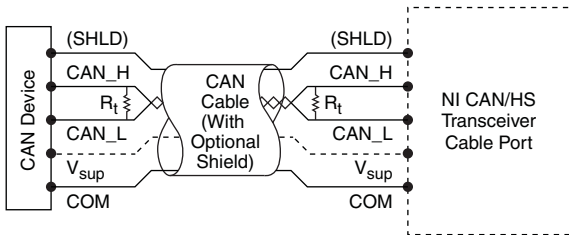

Cabling Requirements to the NI-XNET CAN HS/FD Transceiver Cable

This section deals with cabling specifications, termination resistors, cable lengths, and the number of CAN nodes that can exist in a system.

Cable Specifications

Cables should meet the physical medium requirements specified in ISO 11898, shown in Table 2. Belden cable (3084A) meets all these requirements and should be suitable for most applications.

Table 2. ISO 11898 Specifications for Characteristics of a CAN_H and CAN_L Pair of Wires

Characteristic	Value
Impedance	95 Ω min, 120 Ω nominal, 140 Ω max
Length-related resistance	70 m Ω /m nominal
Specific line delay	5 ns/m nominal

Termination Resistors

The termination resistors (R_t) should match the nominal impedance of the CAN cable and therefore comply with the values in Table 3. The onboard, software-selectable termination has a nominal value of 120 Ω . If you are not using the onboard termination, use the values listed in Table 3.

Table 3. Termination Resistor Specification

Characteristic	Value	Condition
Termination resistor, R_t	100 Ω min, 120 Ω nominal, 130 Ω max	Minimum power dissipation: 220 mW

Cable Lengths

The cabling characteristics and desired bit transmission rates affect the allowable cable length. You can find detailed cable length recommendations in the ISO 11898, CiA DS 102, and DeviceNet specifications.

ISO 11898 specifies 40 m total cable length with a maximum stub length of 0.3 m for a bit rate of 1 Mb/s. The ISO 11898 specification says that significantly longer cable lengths may be

allowed at lower bit rates, but you should analyze each node for signal integrity problems.

Number of CAN Nodes

The maximum number of nodes depends on the electrical characteristics of the nodes on the network. If all nodes meet the ISO 11898 requirements, you can connect at least 30 nodes to the bus. You can connect higher numbers of nodes if the nodes' electrical characteristics do not degrade signal quality below ISO 11898 signal level specifications.

The NI-XNET CAN HS/FD Transceiver Cable electrical characteristics allow at least 110 CAN ports on a network.

NI-XNET CAN HS/FD Transceiver Cable Hardware Overview

The NI-XNET CAN HS/FD Transceiver Cable has one full-featured CAN port that is isolated from the host it is plugged into. The port has an NXP TJA1043T High-Speed CAN transceiver that is fully compatible with the ISO 11898 standard and supports baud rates up to 1 Mbps.

Figure 4. NI-XNET CAN HS/FD Transceiver Cable Hardware Overview

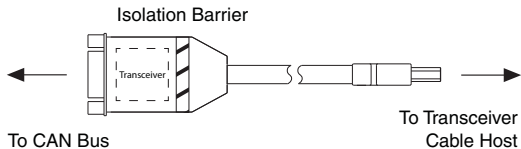

Inserting and Removing the NI-XNET Transceiver Cable

The NI-XNET CAN HS/FD Transceiver Cable connects to a host device with an active latching connector. To connect the NI-XNET CAN HS/FD Transceiver Cable to a host device, push the connector assembly into the host receptacle until the internal latch snaps into position. The latch emits an audible click when engaged. To remove the NI-XNET CAN HS/FD Transceiver Cable, push the lock ejector forward to disengage the latch and simultaneously pull the NI-XNET CAN HS/FD Transceiver Cable, as shown in Figure 5.

Figure 5. Inserting and Removing the NI-XNET Transceiver Cable

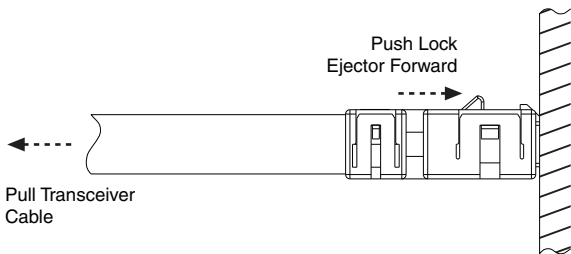

NI-XNET CAN HS/FD Transceiver Cable LEDs

NI-XNET Transceiver Cables include two LEDs per port to help you monitor hardware and bus status. LED 1 primarily indicates whether the hardware is currently in use. LED 2 primarily indicates the activity information of the connected bus. Each LED can display two colors (red or green), which display in the following four patterns:

Table 4. LED Pattern Definitions

Pattern	Meaning
Off	No LED illumination
Solid	LED fully illuminated
Blink	Blinks at a constant rate of several times per second
Activity	Blinks in a pseudo-random pattern

Table 5. LED Pattern Indications

Condition/State	LED 1	LED 2
Port identification	Blinks green	Blinks green
NI-XNET catastrophic error	Blinks red	Blinks red
No open session on hardware	Off	Off
Open session on hardware, port is properly powered, and hardware is not communicating	Solid green	Off
Hardware is communicating, and controller is in Error Active state	Solid green	Activity green (returns to idle/off one second after last TX or RX)
Hardware is communicating, and controller is in Error Passive state	Solid green	Activity red (returns to idle/off one second after last TX or RX)
Hardware is running, and controller transitioned to bus off	Solid green	Solid red

Specifications

The following specifications are typical for the range -40 to 70 °C unless otherwise noted.

High-Speed CAN Characteristics

Transceiver.....	NXP TJA1043T
Max baud rate	1 Mbps
CAN_H, CAN_L bus lines voltage.....	-27 to +40 VDC
MTBF	Contact NI for Bellcore MTBF or MIL-HDBK-217F specifications.

Power Requirements

Thermal dissipation (at 70 °C).....	550 mW max (active mode); 440 mW typical (active mode)
Power consumption from NI-XNET Transceiver Cable host	550 mW max (active mode); 440 mW typical (active mode)



Note The NI-XNET CAN HS/FD Transceiver Cable is internally powered from the host and does not require external power from the CAN Bus.

Physical Characteristics

To clean the transceiver cable, wipe it with a dry towel.

Weight..... Approx. 65 g (2.3 oz)

Safety

Maximum Voltage¹

Connect only voltages that are within these limits.

Port-to-COM..... -27 to +40 VDC max,
Measurement Category I

Measurement Category I is for measurements performed on circuits not directly connected to the electrical distribution system referred to as *MAINS* voltage. *MAINS* is a hazardous live electrical supply system that powers equipment. This category is for measurements of voltages from specially protected secondary

¹ The maximum voltage that can be applied or output between any port and a COM terminal without creating a safety hazard.

circuits. Such voltage measurements include signal levels, special equipment, limited-energy parts of equipment, circuits powered by regulated low-voltage sources, and electronics.



Caution Do *not* connect the NI-XNET CAN HS/FD Transceiver Cable to signals or use for measurements within Measurement Categories II, III, or IV.



Note Measurement Categories CAT I and CAT O (Other) are equivalent. These test and measurement circuits are not intended for direct connection to the MAINs building installations of Measurement Categories CAT II, CAT III, and CAT IV.

Isolation Voltage

Port-to-earth ground

Continuous 60 VDC,
Measurement Category I



Note The NI-XNET CAN HS/FD Transceiver Cable COM signals are not connected to the host port ground. This isolation is intended to prevent ground loops and does not meet UL ratings for safety isolation.

Safety Standards

This product meets the requirements of the following standards of safety for electrical equipment for measurement, control, and laboratory use:

- IEC 61010-1, EN 61010-1
- UL 61010-1, CSA 61010-1
- EN 60079-0:2012, EN 60079-15:2010
- IEC 60079-0: Ed 6, IEC 60079-15: Ed 4
- UL 60079-0: Ed 5, UL 60079-15: Ed 3
- CSA 60079-0:2011, CSA 60079-15:2012



Note For UL and other safety certifications, refer to the product label or the [Online Product Certification](#) section.

Hazardous Locations

U.S. (UL) Class I, Division 2,
Groups A, B, C, D, T4;
Class I, Zone 2,
ATEX nA IIC T4

Canada (C-UL)	Class I, Division 2, Groups A, B, C, D, T4; Class I, Zone 2, Ex nA IIC T4
Europe (DEMKO)	Ex nA IIC T4 Gc

Environmental

Refer to the installation instructions for the host you are using for more information about meeting these specifications.

Operating temperature

(IEC 60068-2-1, IEC 60068-2-2) -40¹ to 70 °C

Storage temperature

(IEC 60068-2-1, IEC 60068-2-2) -40¹ to 85 °C

Ingress protection..... IP 40

Operating humidity

(IEC 60068-2-56)..... 10 to 90% RH,
noncondensing

¹ Similar to other standard PVC cables, this product's cable becomes less ductile at low temperatures. Preroute and secure the cable while flexible to avoid premature failure.

Storage humidity (IEC 60068-2-56).....	5 to 95% RH, noncondensing
Pollution Degree (IEC 60664).....	2
Maximum altitude ¹	5000 m
Indoor use only.	

Shock and Vibration

To meet these specifications, you must securely mount your transceiver cable and ensure all cables and connectors have proper strain relief.

Operating vibration, random (IEC 60068-2-64).....	5 g _{rms} , 10 to 500 Hz
Operating shock (IEC 60068-2-27).....	30 g, 11 ms half sine, 50 g, 3 ms half sine, 18 shocks at 6 orientations

¹ 60 V CAT I, 1000 V Withstand up to 3000 m; 60 V CAT I, 860 V Withstand from 3001 to 5000 m.

Operating vibration, sinusoidal
(IEC 60068-2-6)..... 5 g, 10 to 500 Hz

Electromagnetic Compatibility

This product meets the requirements of the following EMC standards for electrical equipment for measurement, control, and laboratory use:

- EN 61326 (IEC 61326): Class A emissions; Basic immunity
- EN 55011 (CISPR 11): Group 1, Class A emissions
- AS/NZS CISPR 11: Group 1, Class A emissions
- FCC 47 CFR Part 15B: Class A emissions
- ICES-001: Class A emissions



Note For the standards applied to assess the EMC of this product, refer to the [Online Product Certification](#) section.



Note For EMC compliance, operate this product according to the documentation.

CE Compliance

This product meets the essential requirements of applicable European Directives as follows:

- 2006/95/EC; Low-Voltage Directive (safety)
- 2004/108/EC; Electromagnetic Compatibility Directive (EMC)
- 94/9/EC; Potentially Explosive Atmospheres (ATEX)

Online Product Certification

Refer to the product Declaration of Conformity (DoC) for additional regulatory compliance information. To obtain product certifications and the DoC for this product, visit ni.com/certification, search by model number or product line, and click the appropriate link in the Certification column.

Environmental Management

NI is committed to designing and manufacturing products in an environmentally responsible manner. NI recognizes that eliminating certain hazardous substances from our products is beneficial to the environment and to NI customers.

For additional environmental information, refer to the *Minimize Our Environmental Impact* web page at ni.com/environment. This page contains the environmental regulations and directives with which NI complies, as well as other environmental information not included in this document.

Waste Electrical and Electronic Equipment (WEEE)



EU Customers At the end of the product life cycle, all products *must* be sent to a WEEE recycling center. For more information about WEEE recycling centers, National Instruments WEEE initiatives, and compliance with WEEE Directive 2002/96/EC on Waste and Electronic Equipment, visit ni.com/environment/weee.

电子信息产品污染控制管理办法（中国 RoHS）



中国客户 National Instruments 符合中国电子信息产品中限制使用某些有害物质指令 (RoHS)。关于 National Instruments 中国 RoHS 合规性信息, 请登录 ni.com/environment/rohs_china。(For information about China RoHS compliance, go to ni.com/environment/rohs_china.)

Worldwide Support and Services

The National Instruments website is your complete resource for technical support. At ni.com/support you have access to everything from troubleshooting and application development self-help resources to email and phone assistance from NI Application Engineers.

Visit ni.com/services for NI Factory Installation Services, repairs, extended warranty, and other services.

Visit ni.com/register to register your National Instruments product. Product registration facilitates technical support and ensures that you receive important information updates from NI.

A Declaration of Conformity (DoC) is our claim of compliance with the Council of the European Communities using the manufacturer's declaration of conformity. This system affords the user protection for electromagnetic compatibility (EMC) and product safety. You can obtain the DoC for your product by visiting ni.com/certification. If your product supports calibration, you can obtain the calibration certificate for your product at ni.com/calibration.

National Instruments corporate headquarters is located at 11500 North Mopac Expressway, Austin, Texas, 78759-3504. National Instruments also has offices located around the world. For telephone support in the United States, create your service request at ni.com/support or dial 1 866 ASK MYNI (275 6964). For telephone support outside the United States, visit the Worldwide Offices section of ni.com/niglobal to access the branch office websites, which provide up-to-date contact information, support phone numbers, email addresses, and current events.

Refer to the *NI Trademarks and Logo Guidelines* at ni.com/trademarks for more information on National Instruments trademarks. Other product and company names mentioned herein are trademarks or trade names of their respective companies. For patents covering National Instruments products/technology, refer to the appropriate location: **Help»Patents** in your software, the `patents.txt` file on your media, or the *National Instruments Patent Notice* at ni.com/patents. You can find information about end-user license agreements (EULAs) and third-party legal notices in the `readme` file for your NI product. Refer to the *Export Compliance Information* at ni.com/legal/export-compliance for the National Instruments global trade compliance policy and how to obtain relevant HTS codes, ECCNs, and other import/export data. NI MAKES NO EXPRESS OR IMPLIED WARRANTIES AS TO THE ACCURACY OF THE INFORMATION CONTAINED HEREIN AND SHALL NOT BE LIABLE FOR ANY ERRORS. U.S. Government Customers: The data contained in this manual was developed at private expense and is subject to the applicable limited rights and restricted data rights as set forth in FAR 52.227-14, DFAR 252.227-7014, and DFAR 252.227-7015.

© 2014 National Instruments. All rights reserved.