

## COMPREHENSIVE SERVICES

We offer competitive repair and calibration services, as well as easily accessible documentation and free downloadable resources.

## SELL YOUR SURPLUS

We buy new, used, decommissioned, and surplus parts from every NI series. We work out the best solution to suit your individual needs.

 Sell For Cash    Get Credit    Receive a Trade-In Deal

## OBSOLETE NI HARDWARE IN STOCK & READY TO SHIP

We stock **New**, **New Surplus**, **Refurbished**, and **Reconditioned** NI Hardware.



*Bridging the gap between the manufacturer and your legacy test system.*

 1-800-915-6216

 [www.apexwaves.com](http://www.apexwaves.com)

 [sales@apexwaves.com](mailto:sales@apexwaves.com)

*All trademarks, brands, and brand names are the property of their respective owners.*

**Request a Quote**

 **CLICK HERE**

**TRC-8543**

GETTING STARTED GUIDE

# TRC-8543

NI-XNET CAN XS (LS/FT, HS/FD)

Transceiver Cable

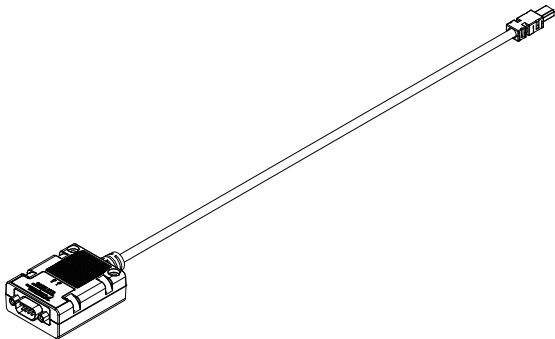

This document explains how to connect the TRC-8543.



**Note** Before you begin, complete the software and hardware installation procedures in your chassis documentation.



**Note** The guidelines in this document are specific to the TRC-8543. The other components in the system might not meet the same safety ratings. Refer to the documentation for each component in the system to determine the safety and EMC ratings for the entire system.

## Safety Guidelines

---

Operate the TRC-8543 only as described in this document.



**Caution** Do not operate the TRC-8543 in a manner not specified in this document. Product misuse can result in a hazard. You can compromise the safety protection built into the product if the product is damaged in any way. If the product is damaged, return it to NI for repair.

## Safety Guidelines for Hazardous Locations

The TRC-8543 is suitable for use in Class I, Division 2, Groups A, B, C, D, T4 hazardous locations; Class I, Zone 2, AEx nA IIC T4 and Ex nA IIC T4 hazardous locations; and nonhazardous locations only. Follow these guidelines if you are installing the TRC-8543 in a potentially explosive environment. Not following these guidelines may result in serious injury or death.



**Caution** Do not disconnect bus-side connector unless power has been switched off or the area is known to be nonhazardous.



**Caution** Do not unplug the TRC-8543 unless power has been switched off or the area is known to be nonhazardous.



**Caution** Substitution of components may impair suitability for Class I, Division 2.



**Caution** For Division 2 and Zone 2 applications, install the system in an enclosure rated to at least IP54 as defined by IEC/EN 60079-15.



**Caution** For Zone 2 applications, install a protection device between the CAN bus and the TRC-8543 CAN pins. The device must prevent the CAN Port-to-COM voltage from exceeding 55 V if there is a transient overvoltage condition.

## Special Conditions for Hazardous Locations Use in Europe and Internationally

The TRC-8543 has been evaluated as Ex nA IIC T4 Gc equipment under DEMKO 12 ATEX 1202658X and is IECEx UL 14.0089X certified. Each TRC-8543 is marked  II 3G and is suitable for use in Zone 2 hazardous locations, in ambient temperatures of  $-40\text{ }^{\circ}\text{C} \leq T_a \leq 70\text{ }^{\circ}\text{C}$ .



**Caution** You must make sure that transient disturbances do not exceed 140% of the rated voltage.



**Caution** The system shall only be used in an area of not more than Pollution Degree 2, as defined in IEC/EN 60664-1.



**Caution** The system shall be mounted in an ATEX/IECEx-certified enclosure with a minimum

ingress protection rating of at least IP54 as defined in IEC/EN 60079-15.



**Caution** The enclosure must have a door or cover accessible only by the use of a tool.

## Electromagnetic Compatibility Guidelines

---

This product was tested and complies with the regulatory requirements and limits for electromagnetic compatibility (EMC) stated in the product specifications. These requirements and limits provide reasonable protection against harmful interference when the product is operated in the intended operational electromagnetic environment.

This product is intended for use in industrial locations. However, harmful interference may occur in some installations, when the product is connected to a peripheral device or test object, or if the product is used in residential or commercial areas. To minimize interference with radio and television reception and prevent unacceptable performance degradation, install and use this product in strict accordance with the instructions in the product documentation.

Furthermore, any changes or modifications to the product not expressly approved by National Instruments could void your authority to operate it under your local regulatory rules.



**Caution** To ensure the specified EMC performance, operate this product only with shielded cables and accessories. Do not use unshielded cables or accessories unless they are installed in a shielded enclosure with properly designed and shielded input/output ports and connected to the product using a shielded cable. If unshielded cables or accessories are not properly installed and shielded, the EMC specifications for the product are no longer guaranteed.

## Mounting the TRC-8543

---



**Caution** The TRC-8543 is a thermally active device that dissipates heat. Refer to the user manual of the host this device directly connects to for specific information regarding thermal management. Not following mounting requirements may affect the system ambient

temperature and/or the measurement accuracy of modules in the system.



**Caution** To meet thermal management requirements, do not zip tie more than six cables in a bundle, and allow for air flow around the bundle. If used with a cRIO or cDAQ chassis, mount all cables at least 152 mm (6.0 in.) from the chassis and do not mount more than six cables directly beneath the chassis.

You can route and strain relieve the TRC-8543 similarly to ordinary cables. You also can panel mount it using its removable jackscrews, zip tie, or screw mount it. The screw mounting holes support #6 and M3 screws spaced 35.56 mm (1.400 in.) center-to-center, with minimum length of 23 mm (7/8 in.). The TRC-8543 supports zip ties up to 5.33 mm (0.210 in.) wide.

The following figure shows jackscrews, zip tie mounting slots, and screw mounting holes on the TRC-8543.



**Figure 1. TRC-8543 Mounting Features**

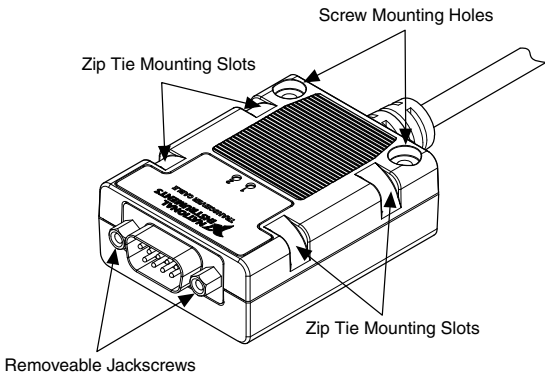

## Panel Mounting the TRC-8543

The recommended panel mounting cutout dimensions are shown below.

**Figure 2.** Recommended Cutout Dimensions

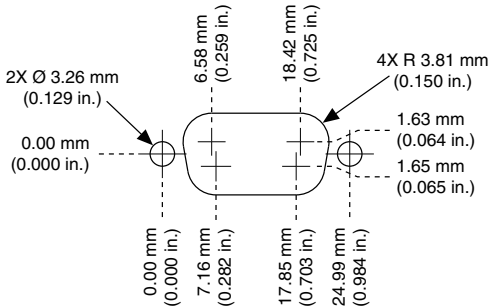

The jackscrews included with the TRC-8543 work with panel thicknesses up to 2.21 mm (0.087 in.).



**Caution** Tighten the jackscrews to a maximum torque of 0.56 N · m (5.0 lb · in.).

If your panel is thicker than 2.21 mm (0.087 in.), you can mill out a recessed pocket for the TRC-8543. The following figure shows the recommended pocket dimensions and cutout position.

**Figure 3. Recommended Pocket Dimensions**

---

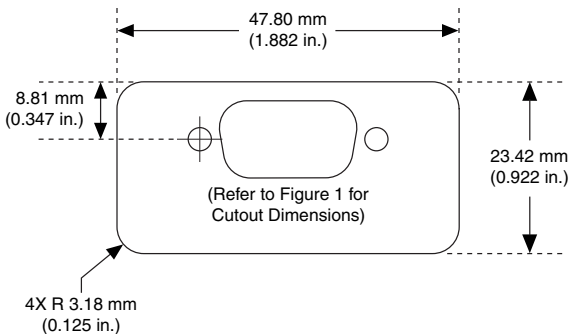

## Wiring to the TRC-8543

---

The TRC-8543 is used with an NI-XNET interface host port.

**Figure 4. TRC-8543 Connections**

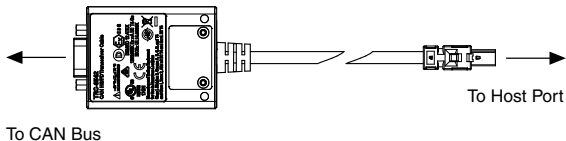

The TRC-8543 has one 9-pin male D-Sub connector that provides connections to a CAN bus. The TRC-8543 has pins for CAN\_H and CAN\_L, to which you connect the CAN bus signals. Connect these signals using twisted-pair cable.

The port has two common pins (COM) that are internally connected to the TRC-8543 isolated reference and serve as the reference ground for CAN\_H and CAN\_L. You can connect the CAN bus reference ground (sometimes referred to as CAN\_V-) to one or both COM pins.

The D-Sub connector shell connects through the TRC-8543 shielding to the connector on the host port end. The shielding does not electrically connect to the COM signals.



**Caution** When tightening the D-Sub connector jackscrews, do not exceed the maximum jackscrew torque of  $0.56 \text{ N} \cdot \text{m}$  ( $5.0 \text{ lb} \cdot \text{in.}$ ).

The TRC-8543 receives power from the NI-XNET host port, but also requires an external power supply of +9 V to +30 V to operate in Low-Speed/Fault-Tolerant mode. Supply power from the CAN bus to the  $V_{\text{SUP}}$  pin.



**Note** Power on  $V_{\text{SUP}}$  is required for Low-Speed/Fault-Tolerant CAN operation, but is not required for High-Speed CAN operation.

The TRC-8543 features software-selectable bus termination for both CAN High-Speed/Flexible Data-Rate and Low-Speed/Fault-Tolerant transceivers. For High-Speed/Flexible Data-Rate mode, you can enable  $115 \Omega$  of termination resistance between  $\text{CAN\_H}$  and  $\text{CAN\_L}$  through an API call. For Low-Speed/Fault-Tolerant mode, you can select either  $1.11 \text{ k}\Omega$  or  $4.99 \text{ k}\Omega$  of termination resistance for RTH and RTL through an API call (refer to the *Termination Resistors* section for more information). If you choose to use external termination, Table 4 lists recommended termination resistor values.

The following table lists the TRC-8543 pinout.

**Table 1.** Pin Assignments for the TRC-8543

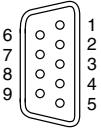
Connector	Pin	Signal Name
	1	No Connection (NC)
	2	CAN_L
	3	COM
	4	NC
	5	NC
	6	COM
	7	CAN_H
	8	NC
	9	V <sub>SUP</sub>

## CAN Bus Topology and Termination

A CAN bus consists of two or more CAN nodes cabled together. The CAN\_H and CAN\_L pins of each node are connected to the

main CAN bus cable through a short connection known as a “stub.” The pair of signal wires, CAN\_H and CAN\_L, constitutes a transmission line. If the transmission line is not terminated, each signal change on the bus causes reflections that may cause communication errors.

## High-Speed/Flexible Data-Rate CAN

Because the CAN bus is bidirectional, both ends of the cable must be terminated. However, this requirement does not mean that every node on the bus should have a termination resistor; only the two nodes at the far end of the cable should have termination resistors.

The following figure shows a simplified diagram of a CAN bus with multiple CAN nodes and proper termination resistor ( $R_t$ ) locations.

**Figure 5.** CAN HS/FD Bus Topology and Termination Resistor Locations

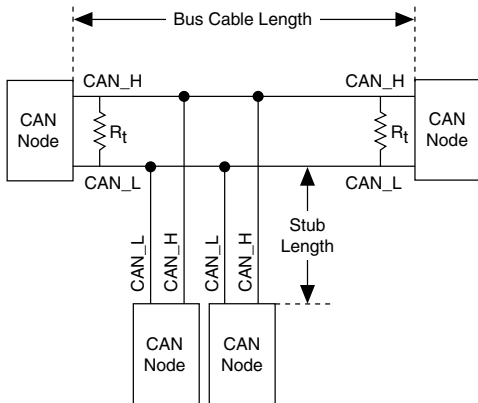



## Low-Speed/Fault-Tolerant CAN

Every device on a low-speed/fault-tolerant CAN network requires a termination resistor for each CAN data line:  $R_{RTH}$  for CAN\_H and  $R_{RTL}$  for CAN\_L.

The following figure shows a simplified diagram of a low-speed/fault-tolerant CAN bus with termination resistor placements.

**Figure 6.** CAN LS/FT Bus Topology and Termination Resistor Locations

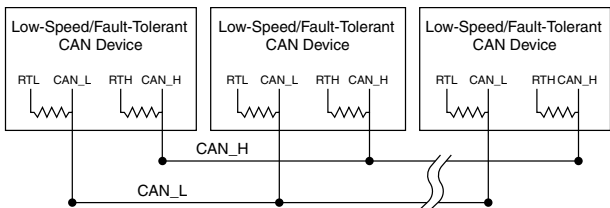

## Connecting a CAN Bus to the TRC-8543

### High-Speed/Flexible Data-Rate CAN

You can connect the TRC-8543 port to any location on a CAN bus. The following figure shows one example of connecting the TRC-8543 directly to one CAN node.

**Figure 7.** Connecting the TRC-8543 to a CAN Device

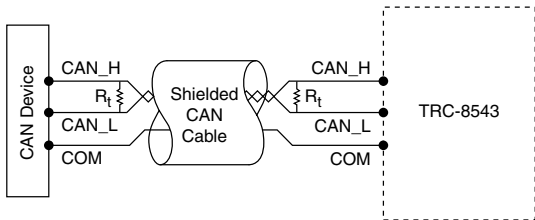

### Low-Speed/Fault-Tolerant CAN

You can connect the TRC-8543 to any location on a Low-Speed/Fault-Tolerant CAN bus. The following figure shows one example of connecting the TRC-8543 directly to one CAN node.

**Figure 8.** Connecting the TRC-8543 to a CAN Device

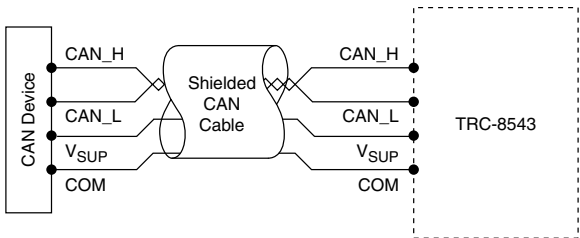

## Cable Specifications

Cables should meet the physical medium requirements specified in ISO 11898, shown in the following tables. Belden cable (3084A) meets all these requirements and should be suitable for most applications.

## High-Speed/Flexible Data-Rate CAN

**Table 2.** ISO 11898 Specifications for Characteristics of a CAN\_H and CAN\_L Pair of Wires

<b>Characteristic</b>	<b>Value</b>
Impedance	95 $\Omega$ min, 120 $\Omega$ nominal, 140 $\Omega$ max
Length-related resistance	70 m $\Omega$ /m nominal
Specific line delay	5 ns/m nominal

## Low-Speed/Fault-Tolerant CAN

**Table 3.** ISO 11898 Specifications for Characteristics of a CAN\_H and CAN\_L Pair of Wires

Characteristic	Value
Length-related resistance	90 m $\Omega$ /m nominal
Length-related capacitance: CAN_L and ground, CAN_H and ground, CAN_L and CAN_H	30 pF/m nominal

## Termination Resistors

---

### High-Speed/Flexible Data-Rate CAN

The termination resistors ( $R_t$ ) should match the nominal impedance of the CAN cable and therefore comply with the values in the following table. The onboard, software-selectable termination has a nominal value of 115  $\Omega$ . If you are not using the onboard termination, use the values listed in the following table.

**Table 4.** Termination Resistor Specification

Characteristic	Value	Condition
Termination resistor, $R_t$	100 $\Omega$ min, 120 $\Omega$ nominal, 130 $\Omega$ max	Minimum power dissipation: 220 mW

## Low-Speed/Fault-Tolerant CAN

Unlike High-Speed/Flexible Data-Rate CAN, Low-Speed/Fault-Tolerant CAN requires termination at the Low-Speed/Fault-Tolerant CAN transceiver instead of on the cable itself.

Termination requires two resistors, RTH for CAN\_H and RTL for CAN\_L. This configuration allows the NXP fault-tolerant CAN transceiver to detect and recover from bus faults. It is important to determine the overall termination of the existing network, or the termination of the individual device, before connecting it to a low-speed/fault-tolerant port. NXP recommends an overall RTH and RTL termination of 100  $\Omega$  to 500  $\Omega$  (each) for a properly terminated low-speed network. You can determine the overall network termination as follows:

$$\frac{1}{R_{RTHoverall}} = \frac{1}{R_{RTHnode1}} + \frac{1}{R_{RTHnode2}} + \frac{1}{R_{RTHnode3}} + \frac{1}{R_{RTHnoden}}$$

NXP also recommends an individual device RTH and RTL termination of 500  $\Omega$  to 16 k $\Omega$ . After determining the existing network or device termination, you can use the following formula to indicate which nearest value the termination property needs to be set to produce the proper overall RTH and RTL termination of 100  $\Omega$  to 500  $\Omega$  upon connection of the card:

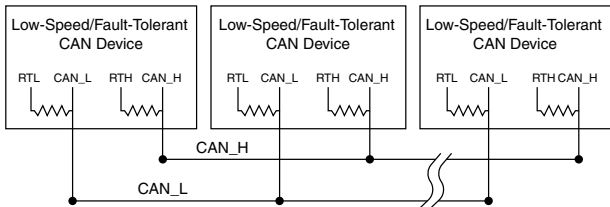

where  $R_{RTHoverall}$  should be 100  $\Omega$  to 500  $\Omega$

NI-XNET Low-Speed/Fault-Tolerant CAN hardware features software selectable bus termination resistors, allowing you to adjust the overall network termination through an API call. In general, if the existing network has an overall network termination of 125  $\Omega$  or less, you should select the 5 k $\Omega$  option for your NI-XNET device. For existing overall network termination above 125  $\Omega$ , you should select the 1 k $\Omega$  termination option for your NI-XNET device.

Onboard termination on the low-speed/fault-tolerant ports of the TRC-8543 is set through the NI-XNET software to either 1.11 k $\Omega$  or 4.99 k $\Omega$ .

## Cable Lengths

---

The cabling characteristics and desired bit transmission rates affect the allowable cable length. You can find detailed cable length recommendations in the ISO 11898, CiA DS 102, and DeviceNet specifications.

ISO 11898 specifies 40 m total cable length with a maximum stub length of 0.3 m for a bit rate of 1 Mb/s. The ISO 11898 specification says that significantly longer cable lengths may be



allowed at lower bit rates, but you should analyze each node for signal integrity problems.

## Number of CAN Nodes

---

### High-Speed/Flexible Data-Rate CAN

The maximum number of nodes depends on the electrical characteristics of the nodes on the network. If all nodes meet the ISO 11898 requirements, you can connect at least 30 nodes to the bus. You can connect higher numbers of nodes if the nodes' electrical characteristics do not degrade signal quality below ISO 11898 signal level specifications.

The TRC-8543 electrical characteristics allow at least 110 CAN ports on a network.

### Low-Speed/Fault-Tolerant CAN

The maximum number of nodes depends on the electrical characteristics of the nodes on the network. If all of the nodes meet the requirements of Low-Speed/Fault-Tolerant CAN, up to 32 nodes may be connected to the bus.

## TRC-8543 Hardware Overview

---

The TRC-8543 has one full-featured CAN port that is isolated from the host it is plugged into. Software can select between either an NXP TJA1043T High-Speed CAN transceiver or NXP TJA1055T Low-Speed/Fault-Tolerant CAN transceiver by controlling on-board relays. The TJA1043T is fully compatible with the ISO 11898 standard and supports baud rates up to 2 Mbps. The NI-XNET driver enables baud rates up to 8 Mbps. The TJA1055T is fully compatible with the ISO 11898 standard and supports baud rates up to 125 Kbps.

**Figure 9.** TRC-8543 Hardware Overview

---

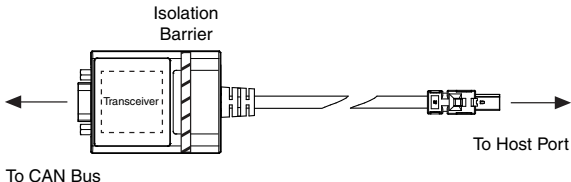

## Inserting and Removing the TRC-8543

---

The TRC-8543 connects to a host device with an active latching connector. To connect the TRC-8543 to a host device, push the connector assembly into the host receptacle until the internal latch snaps into position. The latch emits an audible click when engaged. To remove the TRC-8543, push the lock ejector forward to disengage the latch and simultaneously pull the TRC-8543, as shown in the following figure.

**Figure 10.** Inserting and Removing the TRC-8543

---

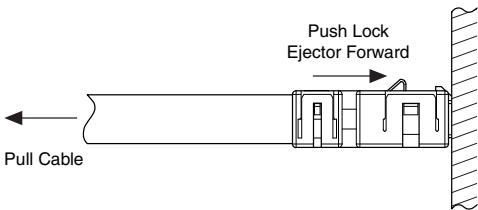

## TRC-8543 LEDs

---

The TRC-8543 includes two LEDs to help you monitor hardware and bus status. LED 1 primarily indicates whether the hardware is currently in use. LED 2 primarily indicates the activity information of the connected bus. Each LED can display two colors (red or green), which display in the following four patterns:

**Table 5.** LED Pattern Definitions

<b>Pattern</b>	<b>Meaning</b>
Off	No LED illumination
Solid	LED fully illuminated
Blink	Blinks at a constant rate of several times per second
Activity	Blinks in a pseudo-random pattern

**Table 6. LED Pattern Indications**

<b>Condition/State</b>	<b>LED 1</b>	<b>LED 2</b>
Port identification	Blinks green	Blinks green
NI-XNET catastrophic error	Blinks red	Blinks red
No open session on hardware	Off	Off
Open session on hardware, port is properly powered, and hardware is not communicating	Solid green	Off
Hardware is communicating, and controller is in Error Active state	Solid green	Activity green (returns to idle/off one second after last TX or RX)

**Table 6.** LED Pattern Indications (Continued)

<b>Condition/State</b>	<b>LED 1</b>	<b>LED 2</b>
Hardware is communicating, and controller is in Error Passive state	Solid green	Activity red (returns to idle/off one second after last TX or RX)
Hardware is running, and controller transitioned to bus off	Solid green	Solid red

## TRC-8543 Specifications

---

The following specifications are typical for the range -40 °C to 70 °C unless otherwise noted.

## High-Speed/Flexible Data-Rate CAN Characteristics

Transceiver	NXP TJA1043T
Max certified baud rate	2 Mbps
Input voltage limits CAN_H, CAN_L bus lines	-27 VDC to +40 VDC
Output voltage limit CAN_H, CAN_L bus lines	5 VDC
MTBF	Contact NI for Bellcore MTBF specifications at other temperatures or MIL-HDBK-217F specifications.

## Low-Speed/Fault-Tolerant CAN Characteristics

Transceiver	NXP TJA1055T
Max baud rate	125 Kbps
CAN_H, CAN_L bus lines voltage	-27 VDC to +40 VDC

CAN Supply voltage range  
( $V_{SUP}$ )

---

+9 VDC to +30 VDC

MTBF

Contact NI for Bellcore MTBF specifications at other temperatures or for MIL-HDBK-217F specifications.

---



## Power Requirements

Thermal dissipation (at 70 °C)	700 mW max (Low-Speed/ Fault-Tolerant fault condition); 550 mW max (High-Speed active mode); 440 mW typical (High-Speed active mode); 333 mW typical (Low-Speed/ Fault-Tolerant active mode)
Power consumption from TRC-8543 host	550 mW max (High-Speed active mode); 440 mW typical (High-Speed active mode); 310 mW max (Low-Speed/ Fault-Tolerant active mode); 245 mW typical (Low-Speed/ Fault-Tolerant active mode)
Power consumption from $V_{SUP}$	320 mW max (Low-Speed/ Fault-Tolerant fault condition); 90 mW typical (Low-Speed/ Fault-Tolerant active mode)



**Note** Power on  $V_{SUP}$  is required for Low-Speed/Fault-Tolerant CAN operation.

## Physical Characteristics

To clean the TRC-8543, wipe it with a dry towel.

Weight	70 g (2.5 oz)
Length	447 mm to 462 mm (17.6 in. to 18.2 in.)
D-Sub connector jackscrew maximum torque	0.56 N · m (5.0 lb · in.)

## Safety

### Maximum Voltage<sup>1</sup>

Connect only the voltages that are within these limits.

Port-to-COM	-27 VDC to +40 VDC max, Measurement Category I
-------------	---

<sup>1</sup> The maximum voltage that can be applied or output without creating a safety hazard.

Measurement Category I is for measurement performed on circuits not directly connected to the electrical distribution system referred to as MAINS voltage. MAINS is a hazardous live electrical supply system that powers equipment. This category is for measurements of voltages from specially protected secondary circuits. Such voltage measurements include signal levels, special equipment, limited-energy parts of equipment, circuits powered by regulated low-voltage sources, and electronics.



**Caution** Do not connect to signals or use for measurements within Measurement Categories II, III, or IV.



**Note** Measurement Categories CAT I and CAT O (Other) are equivalent. These test and measurement circuits are not intended for direct connection to the MAINS building installations of Measurement Categories CAT II, CAT III, and CAT IV.

## Isolation Voltage

---

### Port-to-earth ground

---

Continuous

60 VDC, Measurement  
Category I

---



**Note** The TRC-8543 COM signals are not connected to the host port ground.

## Safety and Hazardous Locations Standards

This product is designed to meet the requirements of the following electrical equipment safety standards for measurement, control, and laboratory use:

- IEC 61010-1, EN 61010-1
- UL 61010-1, CSA 61010-1
- EN 60079-0:2012, EN 60079-15:2010
- IEC 60079-0: Ed 6, IEC 60079-15; Ed 4
- UL 60079-0; Ed 6, UL 60079-15; Ed 4
- CSA 60079-0:2011, CSA 60079-15:2012



**Note** For UL and other safety certifications, refer to the product label or the [Online Product Certification](#) section.

## Hazardous Locations

U.S. (UL)

Class I, Division 2, Groups A, B, C, D, T4; Class I, Zone 2, AEx nA IIC T4

---

Canada (C-UL)

Class I, Division 2, Groups A, B, C, D, T4; Class I, Zone 2, Ex nA IIC T4

---

Europe (DEMKO)

Ex nA IIC T4 Gc

---

## Environmental

Refer to the manual for the host you are using for more information about meeting these specifications.

Operating temperature <sup>2</sup> (IEC 60068-2-1, IEC 60068-2-2)	-40 °C to 70 °C
--	-----------------

---

Storage temperature <sup>2</sup> (IEC 60068-2-1, IEC 60068-2-2)	-40 °C to 85 °C
--	-----------------

---

Ingress protection	IP40
--------------------	------

---

Operating humidity (IEC 60068-2-56)	10% RH to 90% RH, noncondensing
--	------------------------------------

---

Storage humidity (IEC 60068-2-56)	5% RH to 95% RH, noncondensing
--------------------------------------	-----------------------------------

---

<sup>2</sup> Similar to other standard PVC cables, this product's cable becomes less ductile at low temperatures. Preroute and secure the cable while flexible to avoid premature failure.

Pollution Degree (IEC 60664)	2
---------------------------------	---

Maximum altitude	5,000 m
------------------	---------

Indoor use only.

## Shock and Vibration

To meet these specifications, you must securely mount your TRC-8543 and ensure all cables and connectors have proper strain relief.

---

### Operating vibration

Random (IEC 60068-2-64)	5 g <sub>rms</sub> , 10 Hz to 500 Hz
----------------------------	--------------------------------------

Sinusoidal (IEC 60068-2-6)	5 g, 10 Hz to 500 Hz
-------------------------------	----------------------

Operating shock (IEC 60068-2-27)	30 g, 11 ms half sine; 50 g, 3 ms half sine; 18 shocks at 6 orientations
-------------------------------------	--

## Electromagnetic Compatibility

This product meets the requirements of the following EMC standards for electrical equipment for measurement, control, and laboratory use:

- EN 61326-1 (IEC 61326-1): Class A emissions; Industrial immunity
- EN 55011 (CISPR 11): Group 1, Class A emissions
- EN 55022 (CISPR 22): Class A emissions
- EN 55024 (CISPR 24): Immunity
- AS/NZS CISPR 11: Group 1, Class A emissions
- AS/NZS CISPR 22: Class A emissions
- FCC 47 CFR Part 15B: Class A emissions
- ICES-001: Class A emissions



**Note** In the United States (per FCC 47 CFR), Class A equipment is intended for use in commercial, light-industrial, and heavy-industrial locations. In Europe, Canada, Australia and New Zealand (per CISPR 11) Class A equipment is intended for use only in heavy-industrial locations.





**Note** Group 1 equipment (per CISPR 11) is any industrial, scientific, or medical equipment that does not intentionally generate radio frequency energy for the treatment of material or inspection/analysis purposes.



**Note** For EMC declarations and certifications, and additional information, refer to the *Online Product Certification* section.

## CE Compliance

This product meets the essential requirements of applicable European Directives, as follows:

- 2014/35/EU; Low-Voltage Directive (safety)
- 2014/30/EU; Electromagnetic Compatibility Directive (EMC)
- 2014/34/EU; Potentially Explosive Atmospheres (ATEX)

## Online Product Certification

Refer to the product Declaration of Conformity (DoC) for additional regulatory compliance information. To obtain product certifications and the DoC for this product, visit [ni.com/](http://ni.com/)

*certification*, search by model number or product line, and click the appropriate link in the Certification column.

## Environmental Management

NI is committed to designing and manufacturing products in an environmentally responsible manner. NI recognizes that eliminating certain hazardous substances from our products is beneficial to the environment and to NI customers.

For additional environmental information, refer to the *Minimize Our Environmental Impact* web page at [ni.com/environment](http://ni.com/environment). This page contains the environmental regulations and directives with which NI complies, as well as other environmental information not included in this document.

## Waste Electrical and Electronic Equipment (WEEE)



**EU Customers** At the end of the product life cycle, all NI products must be disposed of according to local laws and regulations. For more information about how to recycle NI products in your region, visit [ni.com/environment/weee](http://ni.com/environment/weee).

## 电子信息产品污染控制管理办法（中国 RoHS）



**中国客户** National Instruments 符合中国电子信息产品中限制使用某些有害物质指令 (RoHS)。关于 National Instruments 中国 RoHS 合规性信息，请登录 [ni.com/environment/rohs\\_china](http://ni.com/environment/rohs_china)。(For information about China RoHS compliance, go to [ni.com/environment/rohs\\_china](http://ni.com/environment/rohs_china).)

## Worldwide Support and Services

---

The NI website is your complete resource for technical support. At [ni.com/support](http://ni.com/support), you have access to everything from troubleshooting and application development self-help resources to email and phone assistance from NI Application Engineers.

Visit [ni.com/services](http://ni.com/services) for NI Factory Installation Services, repairs, extended warranty, and other services.

Visit [ni.com/register](http://ni.com/register) to register your NI product. Product registration facilitates technical support and ensures that you receive important information updates from NI.

A Declaration of Conformity (DoC) is our claim of compliance with the Council of the European Communities using the manufacturer's declaration of conformity. This system affords the user protection for electromagnetic compatibility (EMC) and product safety. You can obtain the DoC for your product by visiting [ni.com/certification](http://ni.com/certification). If your product supports calibration, you can obtain the calibration certificate for your product at [ni.com/calibration](http://ni.com/calibration).

NI corporate headquarters is located at 11500 North Mopac Expressway, Austin, Texas, 78759-3504. NI also has offices located around the world. For telephone support in the United States, create your service request at [ni.com/support](http://ni.com/support) or dial 1 866 ASK MYNI (275 6964). For telephone support outside the United States, visit the *Worldwide Offices* section of [ni.com/niglobal](http://ni.com/niglobal) to access the branch office websites, which provide up-to-date contact information, support phone numbers, email addresses, and current events.

Refer to the *NI Trademarks and Logo Guidelines* at [ni.com/trademarks](http://ni.com/trademarks) for information on NI trademarks. Other product and company names mentioned herein are trademarks or trade names of their respective companies. For patents covering NI products/technology, refer to the appropriate location: **Help»Patents** in your software, the `patents.txt` file on your media, or the *National Instruments Patent Notice* at [ni.com/patents](http://ni.com/patents). You can find information about end-user license agreements (EULAs) and third-party legal notices in the readme file for your NI product. Refer to the *Export Compliance Information* at [ni.com/legal/export-compliance](http://ni.com/legal/export-compliance) for the NI global trade compliance policy and how to obtain relevant HTS codes, ECCNs, and other import/export data. NI MAKES NO EXPRESS OR IMPLIED WARRANTIES AS TO THE ACCURACY OF THE INFORMATION CONTAINED HEREIN AND SHALL NOT BE LIABLE FOR ANY ERRORS. U.S. Government Customers: The data contained in this manual was developed at private expense and is subject to the applicable limited rights and restricted data rights as set forth in FAR 52.227-14, DFAR 252.227-7014, and DFAR 252.227-7015.

© 2016 National Instruments. All rights reserved.