

## COMPREHENSIVE SERVICES

We offer competitive repair and calibration services, as well as easily accessible documentation and free downloadable resources.

## SELL YOUR SURPLUS

We buy new, used, decommissioned, and surplus parts from every NI series. We work out the best solution to suit your individual needs.

 Sell For Cash  Get Credit  Receive a Trade-In Deal

## OBSOLETE NI HARDWARE IN STOCK & READY TO SHIP

We stock **New**, **New Surplus**, **Refurbished**, and **Reconditioned** NI Hardware.



*Bridging the gap between the manufacturer and your legacy test system.*

 1-800-915-6216

 [www.apexwaves.com](http://www.apexwaves.com)

 [sales@apexwaves.com](mailto:sales@apexwaves.com)

*All trademarks, brands, and brand names are the property of their respective owners.*

**Request a Quote**

 **CLICK HERE**

**TRC-8546**

GETTING STARTED GUIDE

# NI-XNET LIN Transceiver Cable

Français

Deutsch

日本語

한국어

简体中文

[ni.com/manuals](http://ni.com/manuals)

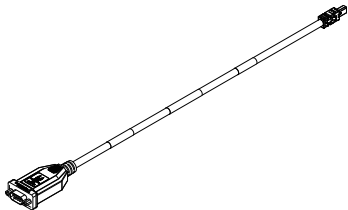

This document explains how to connect to the National Instruments NI-XNET LIN Transceiver Cable.



**Note** Before you begin, complete the software and hardware installation procedures in your chassis documentation.



**Note** The guidelines in this document are specific to the NI-XNET LIN Transceiver Cable. The other components in the system might not meet the same safety ratings. Refer to the documentation for each component in the system to determine the safety and EMC ratings for the entire system.

## Safety Guidelines

---

Operate the NI-XNET LIN Transceiver Cable only as described in this document.



**Hot Surface** This icon denotes that the component may be hot. Touching this component may result in bodily injury.



**Caution** Do not operate the NI-XNET LIN Transceiver Cable in a manner not specified in this document. Product misuse can result in a hazard. You can compromise the safety protection built into the product if the product is damaged in any way. If the product is damaged, return it to NI for repair.

## Safety Guidelines for Hazardous Locations

The NI-XNET LIN Transceiver Cable is suitable for use in Class I, Division 2, Groups A, B, C, D, T4 hazardous locations; Class I, Zone 2, AEx nA IIC T4 and Ex nA IIC T4 hazardous locations; and nonhazardous locations only. Follow these guidelines if you are installing the NI-XNET LIN Transceiver Cable in a potentially explosive environment. Not following these guidelines may result in serious injury or death.



**Caution** Do not disconnect bus-side connector unless power has been switched off or the area is known to be nonhazardous.



**Caution** Do not unplug transceiver cable unless power has been switched off or the area is known to be nonhazardous.



**Caution** Substitution of components may impair suitability for Class I, Division 2.



**Caution** For Division 2 and Zone 2 applications, install the system in an enclosure rated to at least IP54 as defined by IEC/EN 60079-15.



**Caution** For Zone 2 applications, install a protection device between the LIN bus and the NI-XNET LIN Transceiver Cable LIN pins. The device must prevent the LIN Port-to-COM voltage from exceeding 55 V if there is a transient overvoltage condition.

## Special Conditions for Hazardous Locations Use in Europe and Internationally

The NI-XNET LIN Transceiver Cable has been evaluated as Ex nA IIC T4 Gc equipment under DEMKO Certificate No. 12 ATEX 1202658X and is IECEx 14.0089X certified. Each NI-XNET LIN Transceiver Cable is marked Ⓢ II 3G and is suitable for use in Zone 2 hazardous locations.



**Caution** You must make sure that transient disturbances do not exceed 140% of the rated voltage.



**Caution** The system shall only be used in an area of not more than Pollution Degree 2, as defined in IEC 60664-1.



**Caution** The system shall be mounted in an ATEX/IECEX-certified enclosure with a minimum ingress protection rating of at least IP54 as defined in IEC/EN 60079-15.



**Caution** The enclosure must have a door or cover accessible only by the use of a tool.

## Electromagnetic Compatibility Guidelines

---

This product was tested and complies with the regulatory requirements and limits for electromagnetic compatibility (EMC) stated in the product specifications. These requirements and limits provide reasonable protection against harmful interference when the product is operated in the intended operational electromagnetic environment.

This product is intended for use in industrial locations. However, harmful interference may occur in some installations, when the product is connected to a peripheral device or test object, or if the

product is used in residential or commercial areas. To minimize interference with radio and television reception and prevent unacceptable performance degradation, install and use this product in strict accordance with the instructions in the product documentation.

Furthermore, any changes or modifications to the product not expressly approved by National Instruments could void your authority to operate it under your local regulatory rules.



**Caution** To ensure the specified EMC performance, operate this product only with shielded cables and accessories. Do not use unshielded cables or accessories unless they are installed in a shielded enclosure with properly designed and shielded input/output ports and connected to the product using a shielded cable. If unshielded cables or accessories are not properly installed and shielded, the EMC specifications for the product are no longer guaranteed.

## Mounting the NI-XNET LIN Transceiver Cable

---



**Caution** The NI-XNET LIN Transceiver Cable is a thermally active device that dissipates heat. Refer to the user manual of the host this device directly connects to for specific information regarding thermal management. Not following mounting requirements may affect the system ambient temperature and/or the measurement accuracy of modules in the system.

The Transceiver Cable is intended to be routed and strain relieved similar to other cables, and does not require a special mounting accessory.

## Wiring to the NI-XNET LIN Transceiver Cable

---

The NI-XNET LIN Transceiver Cable is used with a compatible NI-XNET Transceiver Cable host port.



**Figure 1. NI-XNET LIN Transceiver Cable Connections**

---

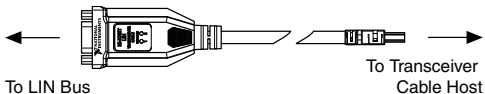

The NI-XNET LIN Transceiver Cable has one 9-pin male D-Sub connector that provides connections to a LIN bus.

The port has two common pins (COM) that are internally connected to the transceiver cable's isolated reference and serve as the reference ground for the LIN signal. You can connect the LIN bus reference ground to one or both COM pins.

The D-Sub connector shell connects through the NI-XNET LIN Transceiver Cable shielding to the connector on the host port end. The shielding does not electrically connect to the COM signals.

The NI-XNET LIN Transceiver Cable gets power from the XNET host port but also requires an external power supply of +8 V to +18 V to operate. Supply power to the NI-XNET LIN Transceiver Cable  $V_{SUP}$  pin from the LIN bus.

The NI-XNET LIN Transceiver Cable pinout is listed in Table 1.

**Table 1.** Pin Assignments for the NI-XNET LIN Transceiver Cable

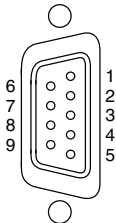
Connector	Pin	Signal Name
	1	No Connection (NC)
	2	NC
	3	COM
	4	NC
	5	NC
	6	COM
	7	LIN
	8	NC
	9	V <sub>SUP</sub>

## Cable Specifications

---

LIN cables should meet the physical medium requirement of a bus RC time constant of 5  $\mu$ s. For detailed formulas for calculating this value, refer to the *Line Characteristics* section of the LIN specification. Belden cable (3084A) and other unterminated CAN/Serial quality cables meet these requirements and should be suitable for most applications.

## Cable Lengths

---

The maximum allowable cable length is 40 m, per the LIN specification.

## Number of LIN Nodes

---

The maximum number of devices on a LIN bus is 16, per the LIN specification.

## Termination Resistors

---

LIN cables require no termination, as nodes are terminated at the transceiver. Slave nodes typically are pulled up from the LIN bus to  $V_{SUP}$  with a 30 k $\Omega$  resistance and a serial diode. This termination usually is integrated into the transceiver package. The master node requires a 1 k $\Omega$  resistor and serial diode between the LIN bus and  $V_{SUP}$ . On NI-XNET LIN products, master termination is software selectable; you can enable it in the API with the NI-XNET Session Interface:LIN:Termination property.

## NI-XNET LIN Transceiver Cable Hardware Overview

---

The NI-XNET LIN Transceiver Cable has one full-featured LIN port that is isolated from the host it is plugged into. The port has an NXP TJA1028 LIN transceiver that is fully compatible with the LIN 1.3/2.0/2.1/2.2 and SAE J2602 standards and supports baud rates up to 20 kbps.

**Figure 2.** NI-XNET LIN Transceiver Cable Hardware Overview

---

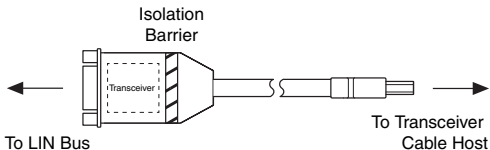

## Inserting and Removing the NI-XNET LIN Transceiver Cable

---

The NI-XNET LIN Transceiver Cable connects to a host device with an active latching connector. To connect the NI-XNET LIN Transceiver Cable to a host device, push the connector assembly into the host receptacle until the internal latch snaps into position. The latch emits an audible click when engaged. To remove the NI-XNET LIN Transceiver Cable, push the lock ejector forward to disengage the latch and simultaneously pull the NI-XNET LIN Transceiver Cable, as shown in the following figure.

**Figure 3.** Inserting and Removing the NI-XNET LIN Transceiver Cable

---

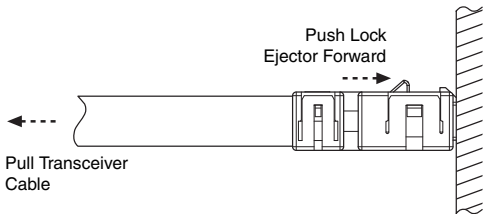

## NI-XNET LIN Transceiver Cable LEDs

---

NI-XNET Transceiver Cables include two LEDs per port to help you monitor hardware and bus status. LED 1 primarily indicates whether the hardware is currently in use. LED 2 primarily indicates the activity information of the connected bus. Each LED can display two colors (red or green), which display in the following four patterns:

**Table 2. LED Pattern Definitions**

<b>Pattern</b>	<b>Meaning</b>
Off	No LED illumination
Solid	LED fully illuminated
Blink	Blinks at a constant rate of several times per second
Activity	Blinks in a pseudo-random pattern

**Table 3. LED Pattern Indications**

<b>Condition/State</b>	<b>LED 1</b>	<b>LED 2</b>
Port identification	Blinks green	Blinks green
NI-XNET catastrophic error	Blinks red	Blinks red
No open session on hardware	Off	Off

**Table 3.** LED Pattern Indications (Continued)

<b>Condition/State</b>	<b>LED 1</b>	<b>LED 2</b>
Open session on hardware, port is properly powered, and hardware is not communicating	Solid green	Off
Open session on hardware, port is missing power	Solid red	Off
Hardware is communicating	Solid green	Activity green (returns to idle/off one second after last TX or RX)

## NI-XNET LIN Transceiver Cable Specifications

---

The following specifications are typical for the range -40 °C to 70 °C unless otherwise noted.



## LIN Characteristics

Transceiver.....	NXP TJA1028
Max baud rate.....	20 kbps
LIN bus lines voltage.....	-40 VDC to +40 VDC
Supply voltage range..... ( $V_{SUP}$ )	+8 VDC to +18 VDC normal operating; -0.3 VDC to +40 VDC absolute limits
MTBF.....	Contact NI for Bellcore MTBF specifications at other temperatures or MIL- HDBK-217F specifications.

## Power Requirements

Thermal dissipation.....	650 mW max (active mode); 330 mW typical (active mode)
Power consumption from.....	330 mW max (active mode); NI-XNET Transceiver Cable host
LIN bus (Vsup).....	320 mW max; 180 mW typical

## Physical Characteristics

To clean the transceiver cable, wipe it with a dry towel.

Weight.....	Approx. 65 g (2.3 oz)
Length.....	450.85 mm to 463.55 mm (17.75 in. to 18.25 in.)

# Safety

## Maximum Voltage<sup>1</sup>

Connect only the voltages that are within these limits.

Port-to-COM.....-40 VDC to +40 VDC max,  
Measurement Category I

Measurement Category I is for measurement performed on circuits not directly connected to the electrical distribution system referred to as MAINS voltage. MAINS is a hazardous live electrical supply system that powers equipment. This category is for measurements of voltages from specially protected secondary circuits. Such voltage measurements include signal levels, special equipment, limited-energy parts of equipment, circuits powered by regulated low-voltage sources, and electronics.



**Caution** Do not connect to signals or use for measurements within Measurement Categories II, III, or IV.

---

<sup>1</sup> The maximum voltage that can be applied or output without creating a safety hazard.



**Note** Measurement Categories CAT I and CAT O (Other) are equivalent. These test and measurement circuits are not intended for direct connection to the MAINs building installations of Measurement Categories CAT II, CAT III, and CAT IV.

## Isolation Voltage

Port-to-earth ground

Continuous.....60 VDC, Measurement Category I



**Note** The NI-XNET LIN Transceiver Cable COM signals are not connected to the host port ground. This isolation is intended to prevent ground loops and does not meet UL ratings for safety isolation.

## Safety and Hazardous Locations Standards

This product is designed to meet the requirements of the following electrical equipment safety standards for measurement, control, and laboratory use:

- IEC 61010-1, EN 61010-1
- UL 61010-1, CSA 61010-1

- EN 60079-0:2012, EN 60079-15:2010
- IEC 60079-0: Ed 6, IEC 60079-15; Ed 4
- UL 60079-0; Ed 5, UL 60079-15; Ed 3
- CSA 60079-0:2011, CSA 60079-15:2012



**Note** For UL and other safety certifications, refer to the product label or the [Online Product Certification](#) section.

## Hazardous Locations

U.S. (UL).....	Class I, Division 2, Groups A, B, C, D, T4; Class I, Zone 2, AEx nA IIC T4
Canada (C-UL).....	Class I, Division 2, Groups A, B, C, D, T4; Class I, Zone 2, Ex nA IIC T4
Europe (DEMKO).....	Ex nA IIC T4 Gc

## Environmental

Refer to the manual for the host you are using for more information about meeting these specifications.

Operating temperature.....-40 °C<sup>2</sup> to 70 °C  
(IEC 60068-2-1, IEC 60068-2-2)

Storage temperature.....-40 °C<sup>2</sup> to 85 °C  
(IEC 60068-2-1, IEC 60068-2-2)

Ingress protection.....IP40

Operating humidity.....10% RH to 90% RH,  
(IEC 60068-2-56) noncondensing

Storage humidity.....5% RH to 95% RH,  
(IEC 60068-2-56) noncondensing

---

<sup>2</sup> Similar to other standard PVC cables, this product's cable becomes less ductile at low temperatures. Preroute and secure the cable while flexible to avoid premature failure.

Pollution Degree.....2  
(IEC 60664)

Maximum altitude.....5,000 m

Indoor use only.

## Shock and Vibration

To meet these specifications, you must securely mount your transceiver cable and ensure all cables and connectors have proper strain relief.

### Operating vibration

Random.....5 g<sub>rms</sub>, 10 Hz to 500 Hz  
(IEC 60068-2-64)

Sinusoidal.....5 g, 10 Hz to 500 Hz  
(IEC 60068-2-6)

Operating shock.....30 g, 11 ms half sine;  
(IEC 60068-2-27) 50 g, 3 ms half sine;  
18 shocks at 6 orientations

## Electromagnetic Compatibility

This product meets the requirements of the following EMC standards for electrical equipment for measurement, control, and laboratory use:

- EN 61326-1 (IEC 61326-1): Class A emissions; Industrial immunity
- EN 55011 (CISPR 11): Group 1, Class A emissions
- EN 55022 (CISPR 22): Class A emissions
- EN 55024 (CISPR 24): Immunity
- AS/NZS CISPR 11: Group 1, Class A emissions
- AS/NZS CISPR 22: Class A emissions
- FCC 47 CFR Part 15B: Class A emissions
- ICES-001: Class A emissions



**Note** In the United States (per FCC 47 CFR), Class A equipment is intended for use in commercial, light-industrial, and heavy-industrial locations. In Europe, Canada, Australia and New Zealand (per CISPR 11) Class A equipment is intended for use only in heavy-industrial locations.





**Note** Group 1 equipment (per CISPR 11) is any industrial, scientific, or medical equipment that does not intentionally generate radio frequency energy for the treatment of material or inspection/analysis purposes.



**Note** For EMC declarations and certifications, and additional information, refer to the *Online Product Certification* section.

## CE Compliance

This product meets the essential requirements of applicable European Directives, as follows:

- 2014/35/EU; Low-Voltage Directive (safety)
- 2014/30/EU; Electromagnetic Compatibility Directive (EMC)
- 94/9/EC; Potentially Explosive Atmospheres (ATEX)

## Online Product Certification

Refer to the product Declaration of Conformity (DoC) for additional regulatory compliance information. To obtain product certifications and the DoC for this product, visit [ni.com/](http://ni.com/)

*certification*, search by model number or product line, and click the appropriate link in the Certification column.

## Environmental Management

NI is committed to designing and manufacturing products in an environmentally responsible manner. NI recognizes that eliminating certain hazardous substances from our products is beneficial to the environment and to NI customers.

For additional environmental information, refer to the *Minimize Our Environmental Impact* web page at [ni.com/environment](http://ni.com/environment). This page contains the environmental regulations and directives with which NI complies, as well as other environmental information not included in this document.

## Waste Electrical and Electronic Equipment (WEEE)



**EU Customers** At the end of the product life cycle, all NI products must be disposed of according to local laws and regulations. For more information about how to recycle NI products in your region, visit [ni.com/environment/weee](http://ni.com/environment/weee).

## 电子信息产品污染控制管理办法（中国 RoHS）



**中国客户** National Instruments 符合中国电子信息产品中限制使用某些有害物质指令 (RoHS)。关于 National Instruments 中国 RoHS 合规性信息，请登录 [ni.com/environment/rohs\\_china](http://ni.com/environment/rohs_china)。(For information about China RoHS compliance, go to [ni.com/environment/rohs\\_china](http://ni.com/environment/rohs_china).)

## Worldwide Support and Services

---

The National Instruments website is your complete resource for technical support. At [ni.com/support](http://ni.com/support), you have access to everything from troubleshooting and application development self-help resources to email and phone assistance from NI Application Engineers.

Visit [ni.com/services](http://ni.com/services) for NI Factory Installation Services, repairs, extended warranty, and other services.

Visit [ni.com/register](https://ni.com/register) to register your National Instruments product. Product registration facilitates technical support and ensures that you receive important information updates from NI.

A Declaration of Conformity (DoC) is our claim of compliance with the Council of the European Communities using the manufacturer's declaration of conformity. This system affords the user protection for electromagnetic compatibility (EMC) and product safety. You can obtain the DoC for your product by visiting [ni.com/certification](https://ni.com/certification). If your product supports calibration, you can obtain the calibration certificate for your product at [ni.com/calibration](https://ni.com/calibration).

National Instruments corporate headquarters is located at 11500 North Mopac Expressway, Austin, Texas, 78759-3504. National Instruments also has offices located around the world. For telephone support in the United States, create your service request at [ni.com/support](https://ni.com/support) or dial 1 866 ASK MYNI (275 6964). For telephone support outside the United States, visit the *Worldwide Offices* section of [ni.com/niglobal](https://ni.com/niglobal) to access the branch office websites, which provide up-to-date contact information, support phone numbers, email addresses, and current events.

Refer to the *NI Trademarks and Logo Guidelines* at [ni.com/trademarks](http://ni.com/trademarks) for information on National Instruments trademarks. Other product and company names mentioned herein are trademarks or trade names of their respective companies. For patents covering National Instruments products/technology, refer to the appropriate location: **Help»Patents** in your software, the `patents.txt` file on your media, or the *National Instruments Patent Notice* at [ni.com/patents](http://ni.com/patents). You can find information about end-user license agreements (EULAs) and third-party legal notices in the readme file for your NI product. Refer to the *Export Compliance Information* at [ni.com/legal/export-compliance](http://ni.com/legal/export-compliance) for the National Instruments global trade compliance policy and how to obtain relevant HTS codes, ECCNs, and other import/export data. NI MAKES NO EXPRESS OR IMPLIED WARRANTIES AS TO THE ACCURACY OF THE INFORMATION CONTAINED HEREIN AND SHALL NOT BE LIABLE FOR ANY ERRORS. U.S. Government Customers: The data contained in this manual was developed at private expense and is subject to the applicable limited rights and restricted data rights as set forth in FAR 52.227-14, DFAR 252.227-7014, and DFAR 252.227-7015.

© 2014—2015 National Instruments. All rights reserved.

374814E-01 Jun15