

## COMPREHENSIVE SERVICES

We offer competitive repair and calibration services, as well as easily accessible documentation and free downloadable resources.

## SELL YOUR SURPLUS

We buy new, used, decommissioned, and surplus parts from every NI series. We work out the best solution to suit your individual needs.

 Sell For Cash    Get Credit    Receive a Trade-In Deal

## OBSOLETE NI HARDWARE IN STOCK & READY TO SHIP

We stock **New**, **New Surplus**, **Refurbished**, and **Reconditioned** NI Hardware.



*Bridging the gap between the manufacturer and your legacy test system.*

 1-800-915-6216

 [www.apexwaves.com](http://www.apexwaves.com)

 [sales@apexwaves.com](mailto:sales@apexwaves.com)

*All trademarks, brands, and brand names are the property of their respective owners.*

**Request a Quote**

 **CLICK HERE**

**USB-6343**

# INSTALLATION GUIDE

# USB X Series Mounting Kit

## For the USB X Series Mounting Kit and USB X Series Mounting Kit with DIN Rail Clip

You can mount your USB X Series device to a wall or panel as described in the *USB X Series Mounting Kit Installation* section, or mount it to a standard DIN rail as described in the *USB X Series Mounting Kit with DIN Rail Clip Installation* section.

### USB X Series Mounting Kit Installation

---

Complete the following steps to mount your USB X Series device to a wall or panel using the USB X Series mounting kit. Refer to Figure 1.

1. Use three #8-32 flathead screws to attach the backpanel wall mount to the panel/wall. Tighten the screws with a #2 Phillips screwdriver to a torque of 1.1 N · m (10 lb · in.).

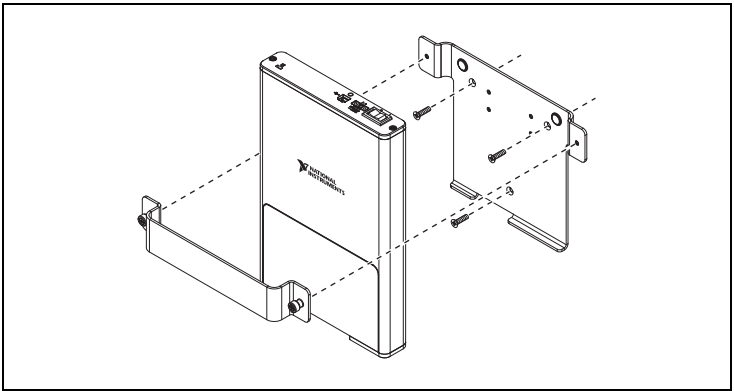

**Figure 1.** Using the USB X Series Mounting Kit on a Wall or Panel

Refer to Figure 2 for the dimensions of the backpanel mounting holes.

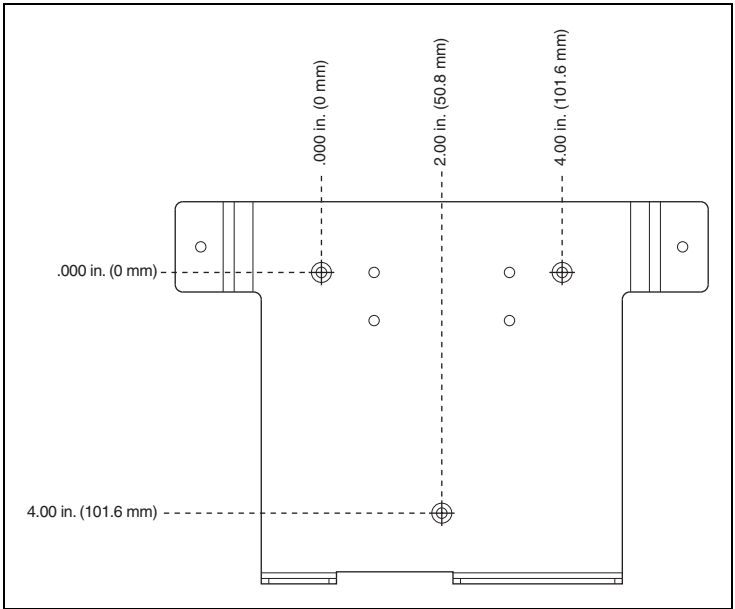

**Figure 2.** Panel Mounting Hole Dimensions

2. Place the USB X Series device on the backpanel wall mount with the signal wires facing down and the device bottom sitting on the backpanel wall mount lip.
3. While holding the USB X Series device in place, attach the front bracket to the backpanel wall mount by tightening the two thumbscrews.

# USB X Series Mounting Kit with DIN Rail Clip Installation

Complete the following steps to mount your USB X Series device to a DIN rail using the USB X Series mounting kit with DIN rail clip.

1. Fasten the DIN rail clip to the back of the backpanel wall mount using a #1 Phillips screwdriver and four machine screws (part number 740981-01), included in the kit, as shown in Figure 3. Tighten the screws to a torque of  $0.4 \text{ N} \cdot \text{m}$  ( $3.6 \text{ lb} \cdot \text{in.}$ ).

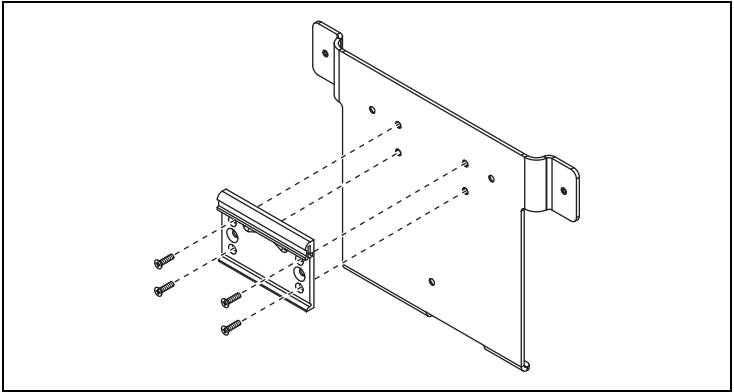

**Figure 3.** Attaching the DIN Rail Clip to the Backpanel Wall Mount

2. Clip the bracket onto the DIN rail as shown in Figure 4.

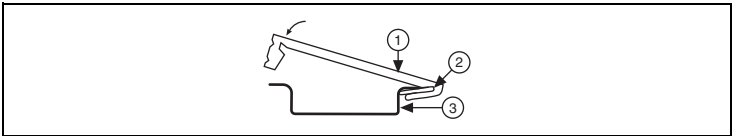

1 DIN Rail Clip

2 DIN Rail Spring

3 DIN Rail

**Figure 4.** DIN Rail Clip Parts Locator Diagram

3. Place the USB X Series device on the backpanel wall mount with the signal wires facing down and the device bottom sitting on the backpanel wall mount lip.
4. While holding the USB X Series device in place, attach the front bracket to the backpanel wall mount by tightening the two thumbscrews.

LabVIEW, National Instruments, NI, ni.com, the National Instruments corporate logo, and the Eagle logo are trademarks of National Instruments Corporation. Refer to the *Trademark Information* at [ni.com/trademarks](http://ni.com/trademarks) for other National Instruments trademarks. Other product and company names mentioned herein are trademarks or trade names of their respective companies. For patents covering National Instruments products/technology, refer to the appropriate location: **Help»Patents** in your software, the `patents.txt` file on your media, or the *National Instruments Patent Notice* at [ni.com/patents](http://ni.com/patents).

© 2010 National Instruments Corp. All rights reserved.