

USER MANUAL

NI 9756

NI Powertrain Controls USB NO_x Sensor Module Kit

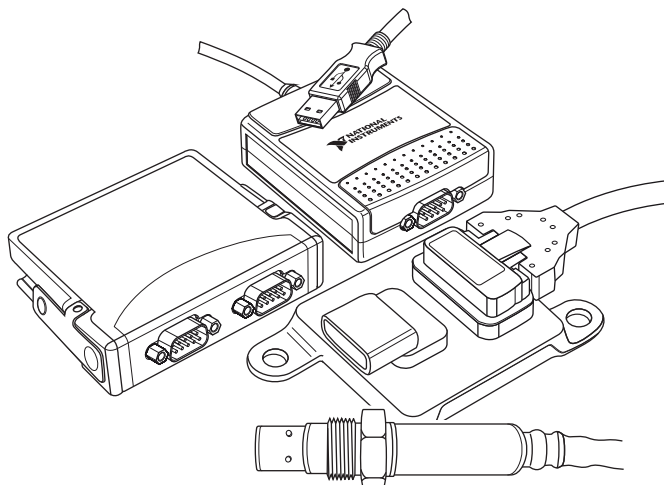

Contents

Introduction	1
System Diagram	2
Hardware	2
Powering the Hardware	3
Wiring Harness	5

Introduction

The National Instruments 9756 USB NO_x Sensor Module Kit interfaces with NO_x and O₂ exhaust gas sensors.

Features

- Configurable for one or two channels
- Measures NO_x (ppm) and O₂ (%) concentrations
- Sensor controller supply voltage of 12 V to 16 V (24 V version available)
- Reverse battery protection on sensor controller module

- Sensor controller harness
- Stand-alone executable that can run without a LabVIEW license
- Windows-based LabVIEW VIs

System Diagram

Figure 1. NI 9756 System

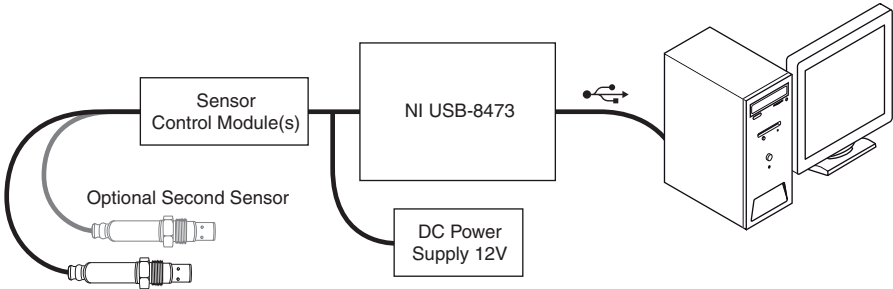

Hardware

The NI 9756 includes the following hardware:

- Continental UniNOx Smart NOx Sensor with an integrated sensor controller module
- Sensor bung
- Wiring harness
- NI USB-8473 USB High-Speed CAN module

The wiring harness in the NI 9756 connects to the NOx Sensor Control Module and splits into two cables for the NI USB-8473 module and an external power supply. The first cable connects to the NI USB-8473 with a female DB-9 connector. A terminating resistor of approximately 120 Ω is located inside this cable near the NOx Sensor Control Module and between the CAN High and CAN Low wires. The second cable provides three non-terminated leads for connecting to a power supply, which requires two leads, and for address selection of the NOx sensor module, which requires one lead.

Refer to the *NI USB-8473 CAN Hardware and Software Manual* for more information about cabling requirements.



Note You must use the sensor included in the NI 9756 kit. NI does not support other sensors.

Powering the Hardware

The NI 9756 requires power from a range of 12 V to 16 V with a continuous current of 1.5 A and a peak current of 16 A. The maximum power requirement is 20 W, which typically occurs when the heating element is being turned on from a cold state. If you are using two sensors, double the capacity of the power supply.

Refer to the *NI USB-8473 Hardware and Software Manual* for more information on power requirements.

Contact National Instruments for more information about sensor specifications.

NOx Sensor Light-Off Times

Conditions

Air T	25 ±5 °C
BattV.....	14 V
Heater.....	ON
NOx	<100 s
O ₂	<80 s

NOx Sensor Preheating Function

When power is supplied to the sensor, the sensor enters preheating mode automatically until the **Sensor Enable** Boolean is set to TRUE within the supporting software. The **Sensor Enable** Boolean turns the internal sensor heater to its ON state. If the **Sensor Enable** Boolean is set to FALSE, the sensor returns to preheating mode. The preheating mode protects the sensor from mechanical cracks caused by water splash.

NOx Sensor Operating Temperature Ranges

Sensor Module Controller Temperature	-40 °C to 105 °C (105 °C to 115 °C for a maximum of 10 minutes)
Storage temperature range	-40 °C to 120 °C
Maximum storage time	2 years
Maximum exhaust gas temperature.....	800 °C (950 °C for a maximum of 100 hours)
Maximum sensor hexagon screw temperature.....	620 °C (650 °C for a maximum of 100 hours)
Maximum sensor grommet temperature.....	200 °C (230 °C for a maximum of 100 hours)
Preheating sensor temperature range.....	80 °C to 120 °C
Lifespan approved by life cycle pattern	2,000 hours or 120 K miles

NOx Sensor Electrical Characteristics

NOx Sensor Supply Voltage

Minimum supply voltage 12 V

Maximum supply voltage 16 V

NOx Sensor Supply Current

Average supply current 1.5A

Peak supply current at switch on 16 A

Supply Power

Maximum supply power 20 W

NOx Sensor Miscellaneous

Thread torque 50 N · m (36.88 lb · ft)

Lubrication Anti-seize compound

Figure 2. Installation Position

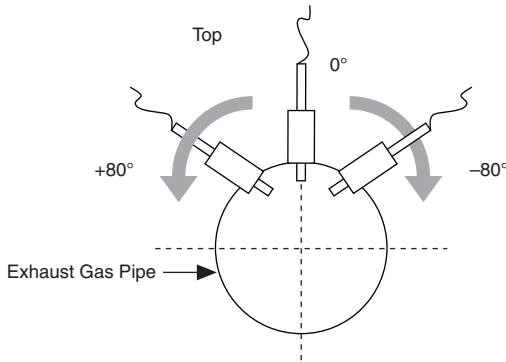
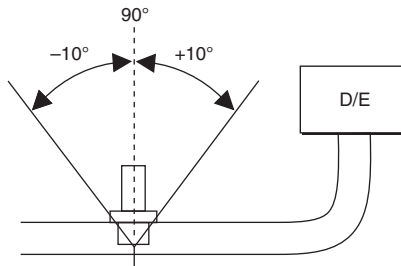

Figure 3. Tilt Angle in Gas Flow Direction



NOx Sensor Controller Module Connector

Type of connector Hirschmann MLK 872-860-501

Number of pins 5

Connector pin assignment

- Pin 1 Battery [red]
- Pin 2 Ground [black]
- Pin 3 CAN Low [blue]
- Pin 4 CAN High [orange]
- Pin 5 Address Switch [purple]

Pulling Pin 5 to ground changes the CAN transmit ID of the Sensor Control Module so that two NOx Sensor Control Modules can be added to the same network. Sensor Control Modules with Pin 5 floating are Ch. 1 and Sensor Control Modules with Pin 5 grounded are Ch. 2.

Wiring Harness

Figure 4. 2-Sensor Harness

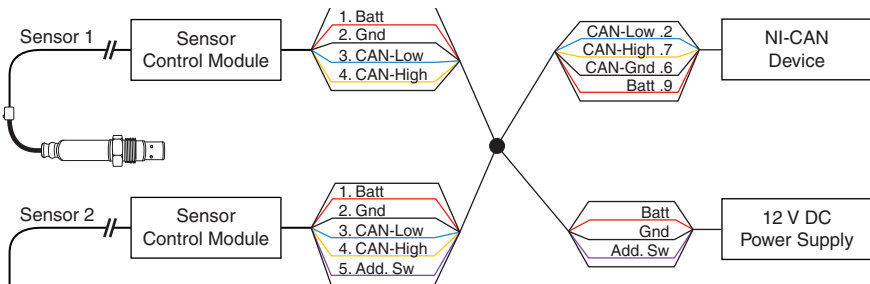

- Each leg from the junction is 4 ft
- Batt and Gnd wires are 18 AWG, CAN wires are 20 AWG
- 120 Ω resistors across CAN-Low and CAN-High near sensor 1 and 2
- NI-CAN devices connect to the harness through a female DB-9 connector
- CAN-Ground is connected to Ground near junction
- Add. Sw should be connected to ground at the power supply

Refer to the *NI Trademarks and Logo Guidelines* at ni.com/trademarks for more information on NI trademarks. Other product and company names mentioned herein are trademarks or trade names of their respective companies. For patents covering NI products/technology, refer to the appropriate location: **Help»Patents** in your software, the `patents.txt` file on your media, or the *National Instruments Patents Notice* at ni.com/patents. You can find information about end-user license agreements (EULAs) and third-party legal notices in the `readme` file for your NI product. Refer to the *Export Compliance Information* at ni.com/legal/export-compliance for the NI global trade compliance policy and how to obtain relevant HTS codes, ECCNs, and other import/export data. NI MAKES NO EXPRESS OR IMPLIED WARRANTIES AS TO THE ACCURACY OF THE INFORMATION CONTAINED HEREIN AND SHALL NOT BE LIABLE FOR ANY ERRORS. U.S. Government Customers: The data contained in this manual was developed at private expense and is subject to the applicable limited rights and restricted data rights as set forth in FAR 52.227-14, DFAR 252.227-7014, and DFAR 252.227-7015.

© 2013–2016 National Instruments. All rights reserved.