

COMPREHENSIVE SERVICES

We offer competitive repair and calibration services, as well as easily accessible documentation and free downloadable resources.

SELL YOUR SURPLUS

We buy new, used, decommissioned, and surplus parts from every NI series. We work out the best solution to suit your individual needs.

 Sell For Cash  Get Credit  Receive a Trade-In Deal

OBSOLETE NI HARDWARE IN STOCK & READY TO SHIP

We stock **New**, **New Surplus**, **Refurbished**, and **Reconditioned** NI Hardware.



Bridging the gap between the manufacturer and your legacy test system.

 1-800-915-6216

 www.apexwaves.com

 sales@apexwaves.com

All trademarks, brands, and brand names are the property of their respective owners.

Request a Quote

 **CLICK HERE**

VXI-1501

VXI-1501 ADVANCED RACK MOUNT KIT

This kit includes heavy-duty slides for mounting the VXI-1501 chassis into a VXI cabinet, a cable tray kit, a horizontal filler panel, flanges for mounting the chassis to the cabinet, and handles for easy handling of the chassis when sliding the chassis into and out of the VXI cabinet.

For installation instructions, see the [Installing the Rack Mount Flanges and Handles](#) section. You must install all accessories in the order shown in this installation guide (with the exception of the horizontal filler panel, which is optional).



Note When installing the separate components of this rack mount kit, refer to this installation guide only. Disregard any other instructions included with each individual component.

Installing the Rack Mount Flanges and Handles



Caution Use both handles when lifting units that weigh more than 40 lbs. (18.2 kg). Do *not* lift using the handles on units weighing more than 80 lbs. (36.5 kg). Do *not* mount the chassis using only the flanges. The chassis must be supported by this slide kit, the rail kit (offered by National Instruments as the Basic Rack Mount Kit), or a cabinet shelf.

Follow these steps to install the rack mount flanges and handles:

1. Remove the side trim strips from the VXI-1501, as shown in Figure 1.

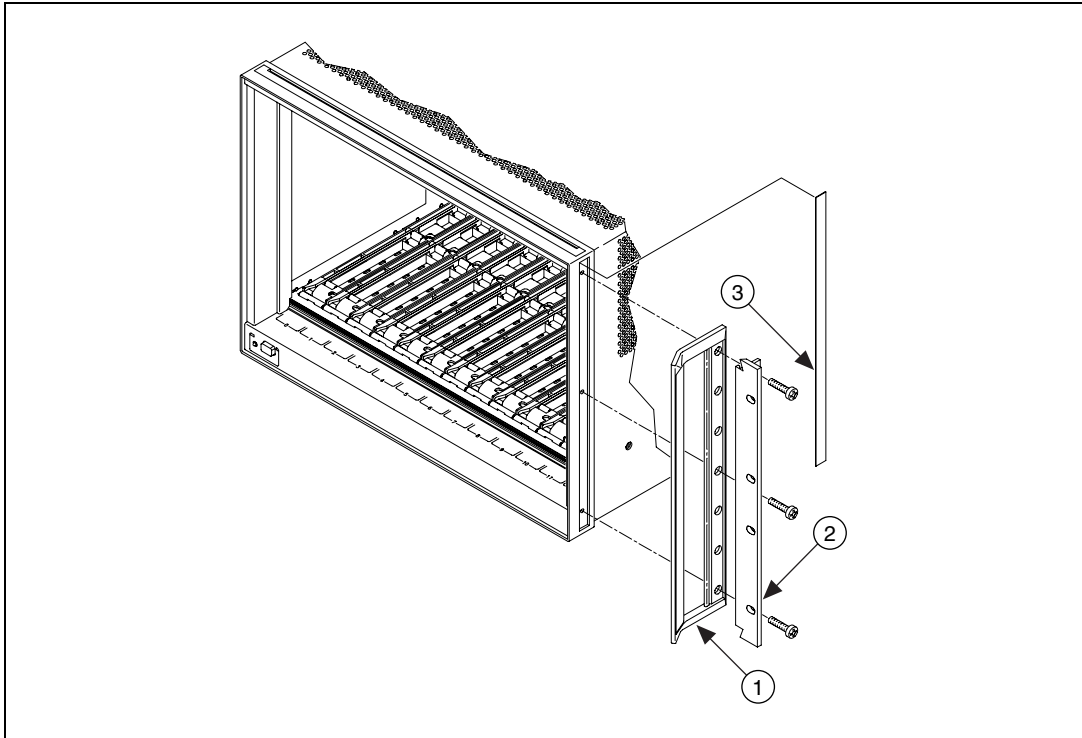

1 Handle (Qty. 2)

2 Rack Mount Flange (Qty. 2)

3 Side Trim Strip

Figure 1. Installing the Rack Mount Flanges and Handles

2. Attach the rack mount flanges and front handle assemblies with three M4×16L screws per side (included with the kit). See Figure 1.

Installing the Cable Tray



Note You *must* install the cable tray prior to installing the slide kit.

Choose one of the two installation options for the cable tray depth. The tray can be mounted in the standard tray depth position or the deep tray depth position. See Figure 2.

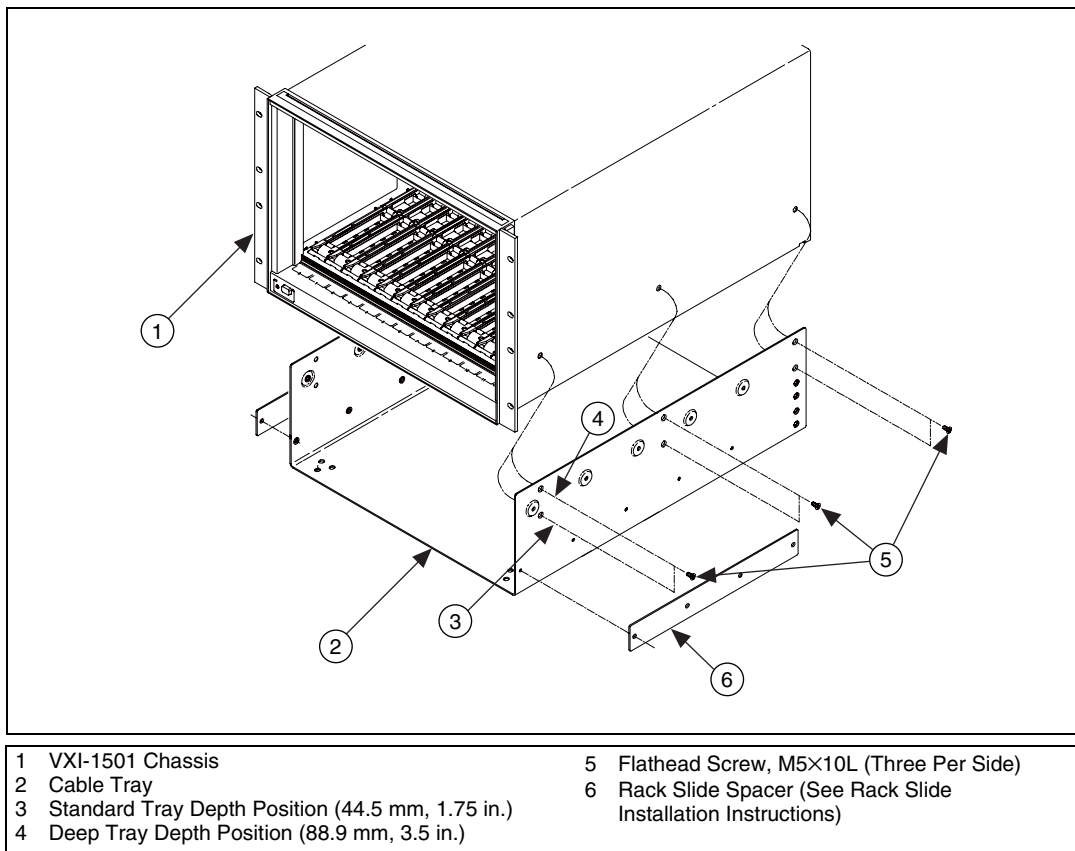

Figure 2. Installing the Cable Tray

Follow these steps to install the cable tray:

1. Place the VXI-1501 on its rear feet.
2. Mount the cable tray using three of the M5×10L flathead screws (packaged with the cable tray spacers) on each side of the chassis. Using the tray holes as a guide, make sure the tray is oriented correctly as shown in Figure 2.

Note that the cable tray has holes on the bottom for the chassis feet, should you decide to use the chassis on a bench top when it is not rack mounted.

Installing the Rack Slides



Note Do not use the bag of hardware and two metal strips packaged with the rack slides. Use the hardware included with the adapter bracket kits for the rack slide installation.

For the following instructions, refer to Figure 3:

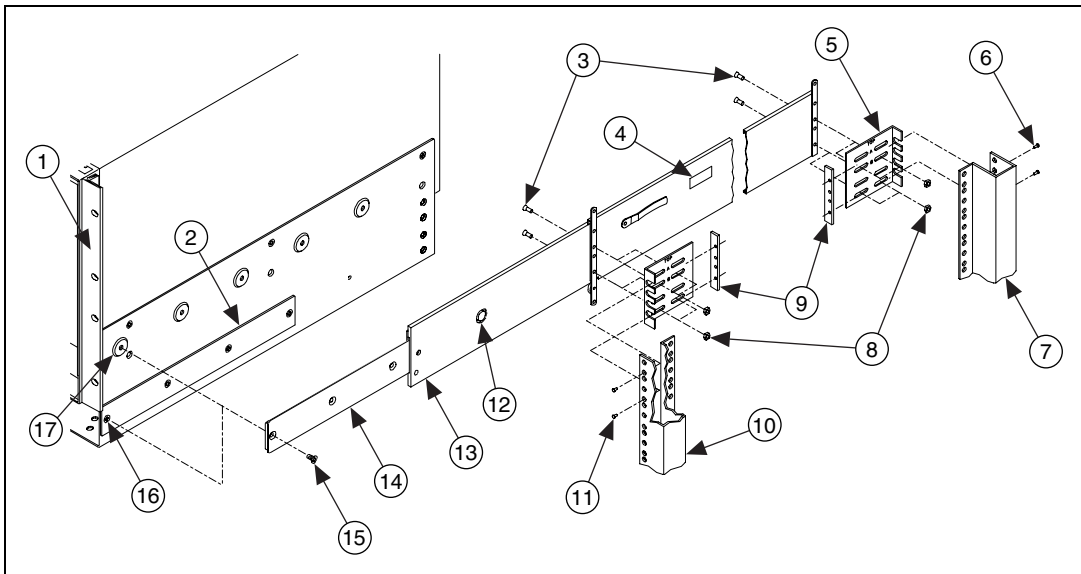

1 Flange	10 Front Rack Rail
2 Spacer	11 Front Flat Head Screw M5×12L (Qty. 4, Two Places Per Front Rail)
3 Pan Head Screw, M5×12L (Qty. 8, Two Per Bracket)	12 Release Button
4 Slide Label	13 Rack Slide (Qty. 2)
5 Adapter Bracket (Qty. 4)	14 Inner Rail (Qty. 2)
6 Rear Pan Head Screw, M5×12L (Qty. 4, Two Places Per Rear Rail)	15 Flat Head Screw, M5×10L (Qty. 8, Four Places Per Side)
7 Rear Rack Rail	16 Lower Mount Position
8 Nut, M5 (Qty. 8)	17 Upper Mount Position
9 Nut Bar, M5 (Qty. 4)	

Figure 3. Installing the Rack Slides

1. Press the release button to separate the inner rail from each rack slide. Note that the left and right slide rails are not identical and thus are labeled *RH* for the right rail and *LH* for the left rail. When separating the inner rails, note which one goes with the right slide and which goes with the left slide.

2. Mount the inner rails directly to the cable tray to either the upper mount position or the lower mount position. If installing the inner rail in the lower mount position, you must use the spacer (included with the cable tray kit) on both sides. Because of variances in VXI racks and their rails, you may want to try both configurations to see if one is better suited for your particular rack. There may be several lengths of screws included with your rack mount kit. Be sure to use the shorter flat head screws (M5×10L) when attaching the inner rails. (These screws are packaged with the cable tray spacers.) Be sure the release button on the inner rail is toward the rear of the chassis and facing outward as shown in Figure 3, and the roller wheel on the inner rail is toward the top of the chassis.



Note If the inner rail is mounted in the wrong position, the slide may overextend, lock in the wrong position, or not fully insert.

3. Most VXI racks will require that the adapter kit be attached to the slide rails prior to installing them into the rack. Install the adapter brackets to the slides as shown in Figure 3 using two M5×12L pan head screws and two M5 hex nuts per bracket (included with the adapter kit). Some adjustments may be necessary, depending on your particular rack. Tighten the nuts after making any adjustments.



Note Depending on your particular VXI rack, you may be able to mount the slide rack assembly directly to the cabinet rails without using the adapter kit. Should you try this, remember that depending on which holes in the rack rails you use to mount the slide assembly, the holes in the flanges may not line up with the front rail holes. Thus, you could not secure the front of the chassis to the front rack rails.

4. Install both slide assemblies to the VXI rack using the nut bars and the M5×12L flat head screws for attachment to the front rack rails and the M5×12L pan head screws for attachment to the rear rack rails. Be sure the slide assembly is level. Use the exact holes specified in Figure 3; otherwise, the flange holes may not line up properly with the rack rail holes.

It may be easier to install the screws and nut bars loosely to the rack in the desired location first, attach the slide assembly to the rack, and then tighten the screws.



Note You must mount flanges or mass interconnect products onto the chassis *before* inserting the chassis into the rack slides.



Caution To prevent injury during rack mounting, the chassis should be empty and two people should lift the chassis into the rack.

5. Extend the rack slides and insert the chassis with mounted rails into the slides. Depress the release button on both sides so that you can fully insert the chassis.
6. Secure the chassis to the front rack rails with the hardware included in the handle and flange kit.

Installing the Horizontal Filler Panel

Once the VXI-1501 is mounted in the rack, you may want to install the 1U filler panel above it as shown in Figure 4. This panel allows adequate air ventilation for the vent holes on top of the chassis, should another piece of equipment be installed above it.

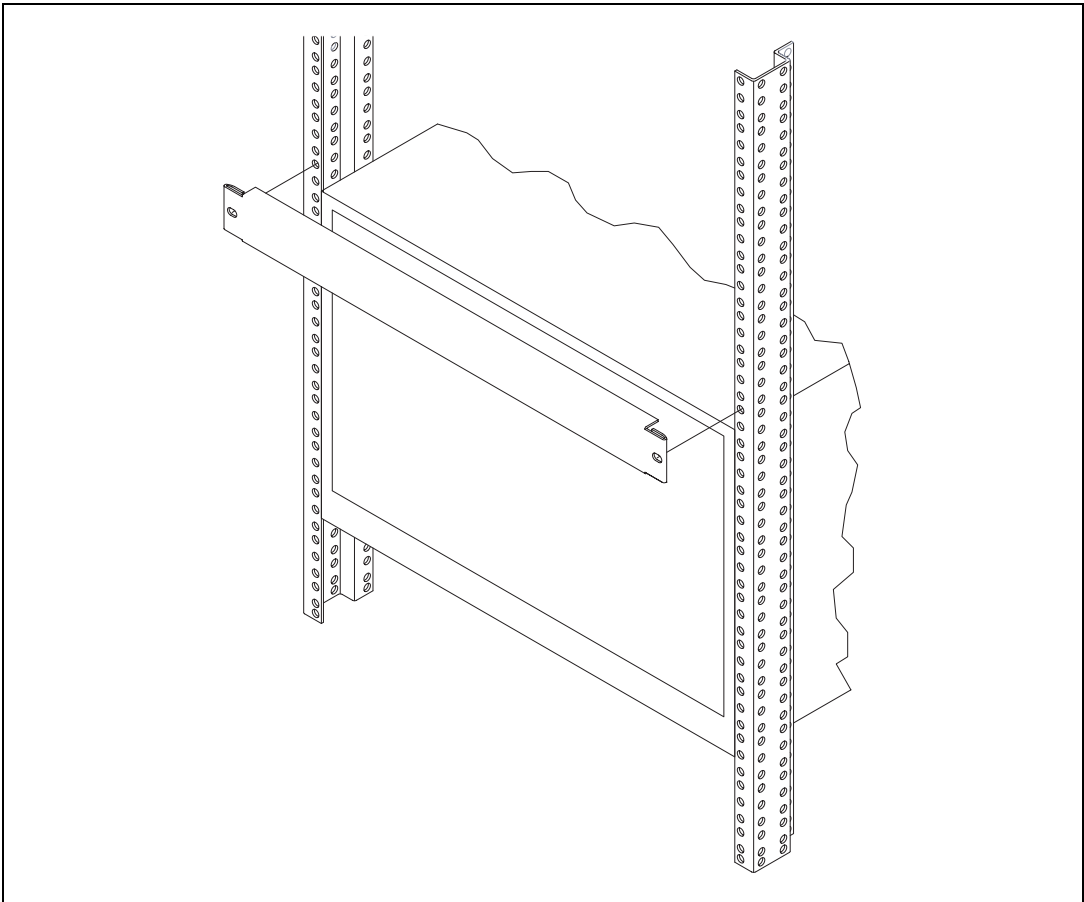

Figure 4. Installing the Horizontal Filler Panel