

COMPREHENSIVE SERVICES

We offer competitive repair and calibration services, as well as easily accessible documentation and free downloadable resources.

SELL YOUR SURPLUS

We buy new, used, decommissioned, and surplus parts from every NI series. We work out the best solution to suit your individual needs.

 Sell For Cash  Get Credit  Receive a Trade-In Deal

OBSOLETE NI HARDWARE IN STOCK & READY TO SHIP

We stock **New**, **New Surplus**, **Refurbished**, and **Reconditioned** NI Hardware.



Bridging the gap between the manufacturer and your legacy test system.

 1-800-915-6216

 www.apexwaves.com

 sales@apexwaves.com

All trademarks, brands, and brand names are the property of their respective owners.

Request a Quote

 **CLICK HERE**

VXI-8340

VXI-8340 SERIES INSTALLATION AND CONFIGURATION

Installation Guide

This document explains how to install and configure your VXI-8340 series controller.

Installing the Software

Use the Setup program that came with your NI-VISA/NI-VXI software to install the entire software package or a software update, or to reinstall software in the event that your files are accidentally erased.

Some of the utilities rely on the LabWindows/CVI Run-Time Engine. This software is installed, if necessary, during the NI-VISA/NI-VXI installation.

To be compliant with VXI*plug&play* specifications, a VXI controller must provide the VISA I/O driver library standardized by VXI*plug&play*. VISA ensures that your controller can run all VXI*plug&play*-compatible software now and in the future.

CVI™, National Instruments™, NI™, ni.com™, NI-VISA™, and NI-VXI™ are trademarks of National Instruments Corporation. Product and company names mentioned herein are trademarks or trade names of their respective companies.

October 2001
323066C-01

ni.com

© 2001 National Instruments Corp. All rights reserved.



The NI-VISA software in this kit is compatible with the WINNT/GWINNT framework. With NI-VISA installed on your computer, you can run any *VXIplug&play* software that is compatible with this framework. This includes instrument drivers and executable soft front panel software that are included with *VXIplug&play*-compatible instruments from a variety of vendors.

Install the NI-VISA and NI-VXI Software

This section describes how to install the NI-VISA and NI-VXI software. Read these directions carefully along with any messages on the screen before making your selections.

You can quit the Setup program at any time by pressing the **Cancel** button.

Setup is an interactive, self-guiding program that installs the NI-VISA and NI-VXI software and configures your system to use the software with the VXI-8340 series. Follow these steps to perform the installation:

1. Insert the CD-ROM labeled *NI-VXI v. 3.2 for Windows*.
2. Wait for Windows to launch the CD-ROM installation menu automatically. (If this does not happen, open the CD-ROM from Windows Explorer and double-click **Autorun**.)
3. Click on **Install NI-VXI Software for Windows**.
4. Click on the **Next** button at the **Welcome** screen to start the installation.



Note If you have a previous 32-bit (Windows 2000/NT4/98) version of the NI-VXI software installed, Setup installs the new version over the previous version.

5. Select the destination for the installed files. The default is `C:\Program Files\National Instruments`.
6. Select the type of installation from the **Installation Options** screen:
 - **Typical** setup prompts you to make high-level choices of which driver(s) to install and the destination directories.
 - **Custom** setup gives you more control over which driver components you want installed on your system. This option is recommended for advanced users.
7. Follow the prompts. Confirm that you are ready to install and click **Next** to begin the installation.
8. Setup now copies the necessary files to your hard drive and creates program icons.

Complete the Software Installation

1. Review the information in any `readme` files that Setup prompts you to read.
2. When the installation process completes, restart the system for the changes to take effect.



Note On some Windows systems, the OS will detect the MXI-3 interface as a “PCI Standard PCI-to-PCI Bridge,” and Windows may ask you to specify the location of a driver information file (`.inf`) for the device. If this occurs, accept the default choices by clicking **Next** when prompted.

Installing the Hardware

This section summarizes how to install your VXI-8340 series hardware. Your kit contains a VXI-8340 series interface module and may also contain a PCI-8330 series interface board and MXI-3 cable.



Caution To guard against electrostatic discharge, touch the antistatic plastic packages to a metal part of your computer or chassis before removing the boards from their packages. Your computer or chassis should be plugged in but powered off.

Figure 1 shows a system with a PCI bus-equipped computer and a VXI chassis with a VXI-8340 series module.

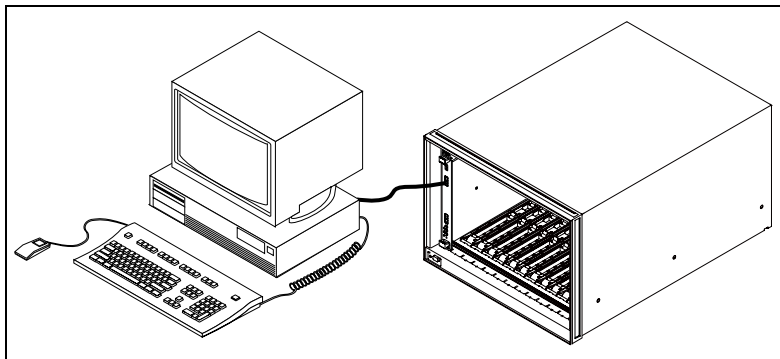
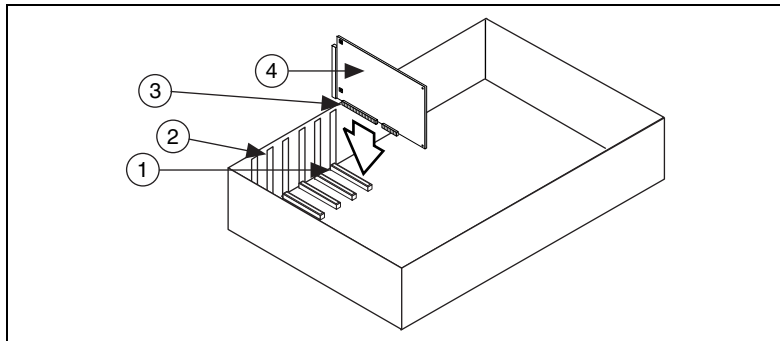

Figure 1. Typical VXI System with a VXI-8340 Series Interface Module

Install Your PCI-8330 Series Interface Board

If your kit includes a PCI-8330 series board, follow these installation instructions:

1. Shut down and power off the computer.
2. Remove the computer chassis cover to expose the expansion slots and covers.
3. Select an available PCI slot in your computer. The slot you select should support bus mastering. Refer to your computer documentation to determine if the slot you select supports bus mastering.
4. Remove the corresponding expansion slot cover from the chassis.
5. Align the bus connector on the PCI-8330 series with the PCI bus slot.



- | | |
|---------------------------|-------------------------|
| 1 PCI Bus Slot | 3 Bus Connector |
| 2 Expansion Slot Cut-Outs | 4 PCI-8330 Series Board |

Figure 2. Installing the PCI-8330 Series Interface Board

- Carefully press the host adapter into the slot.
- Secure the PCI-8330 series bracket to the computer chassis with the screw from the removed expansion slot cover.

Install Your VXI-8340 Series Interface Module

Install the VXI-8340 series in Slot 0 of your VXI chassis by doing the following:

- Turn off the power.
- Insert the VXI-8340 series into the chassis in Slot 0 as shown in Figure 1.
- Verify that all other VXI devices with system controller capability that are in the same chassis are *not* configured as system controller. The VXI-8340 series default configuration automatically detects whether it should be the VXI system controller.



Caution Having more than one device configured as system controller can damage the VXI system.

- For VXI systems that include VME devices, ensure that the VME devices are not configured in the upper 16 KB (starting from 0xC000) of the A16 address space. This region is reserved for VXI device configuration registers, which are used for initializing, configuring, and interacting with VXI devices.



Note Also ensure that no other VXI devices in your system are configured for logical address 0. This is the default configuration for the VXI-8340 series.

Connect the Cable

Connect the MXI-3 cable to the PCI-8330 series and the MXI IN port of the VXI-8340 series as shown in Figure 1.

Power on the System

1. Be sure the MXI-3 cable is connected securely.
2. Turn on the VXI chassis.



Note Always power on the VXI-8340 series at least 8 seconds before your PC. Refer to Appendix D, *Power Sequencing Requirements*, of the *VXI-8340 Series User Manual* for more information regarding power-up requirements for the VXI-8340 series controllers. (The manual is in PDF format on the *NI-VXI v. 3.2 for Windows* CD-ROM.)

3. Turn on the host computer.
4. If your system CMOS setup requires you to adjust PCI bus parameters, do so at this time.



Note The PCI bus usually assigns IRQs and port addresses automatically. However, in some PC systems, you may need to edit the PCI bus parameters manually in your CMOS setup. Some older PCs also require bus mastering to be enabled. Refer to your computer documentation for further instructions.

Software Configuration and Verification

Run MAX and Resman

1. Launch MAX from its desktop icon or **Start»Programs»National Instruments»Measurement & Automation Explorer**. MAX allows you to run Resman, the National Instruments Resource Manager. You must run Resman every time the chassis power is cycled so that your application can access devices in the VXI chassis. Refer to Appendix D, *Power Sequencing Requirements*, of the *VXI-8340 Series User Manual* for more information regarding power-cycling requirements for the VXI-8340 series controllers.
2. After you run Resman, you are ready to use MAX to configure the National Instruments hardware in your system interactively. You can also configure MAX to run Resman automatically at every computer startup by selecting **Tools»NI-VXI»VXI Options**.
3. After you finish configuring the system through MAX, verify the system configuration through one of the interactive control utilities. Use VISAIC under NI-VISA or VIC under NI-VXI. You can also open VISA sessions using MAX by right-clicking on the device and selecting **Open VISA Session**.

For more details about the utilities in NI-VISA/NI-VXI, refer to Chapter 3, *Developing Your Application*, in the *VXI-8340 Series User Manual*.