

COMPREHENSIVE SERVICES

We offer competitive repair and calibration services, as well as easily accessible documentation and free downloadable resources.

SELL YOUR SURPLUS

We buy new, used, decommissioned, and surplus parts from every NI series. We work out the best solution to suit your individual needs.

 Sell For Cash  Get Credit  Receive a Trade-In Deal

OBSOLETE NI HARDWARE IN STOCK & READY TO SHIP

We stock **New**, **New Surplus**, **Refurbished**, and **Reconditioned** NI Hardware.



Bridging the gap between the manufacturer and your legacy test system.

 1-800-915-6216

 www.apexwaves.com

 sales@apexwaves.com

All trademarks, brands, and brand names are the property of their respective owners.

Request a Quote

 **CLICK HERE**

VXI-MIO-64E-1

DAQ

DAQ-STC™ Technical Reference Manual

System Timing Controller for Data Acquisition

Internet Support

E-mail: support@natinst.com

FTP Site: <ftp.natinst.com>

Web Address: <http://www.natinst.com>

Bulletin Board Support

BBS United States: 512 794 5422

BBS United Kingdom: 01635 551422

BBS France: 01 48 65 15 59

Fax-on-Demand Support

512 418 1111

Telephone Support (USA)

Tel: 512 795 8248

Fax: 512 794 5678

International Offices

Australia 03 9879 5166, Austria 0662 45 79 90 0, Belgium 02 757 00 20, Brazil 011 288 3336,
Canada (Ontario) 905 785 0085, Canada (Québec) 514 694 8521, Denmark 45 76 26 00, Finland 09 725 725 11,
France 01 48 14 24 24, Germany 089 741 31 30, Hong Kong 2645 3186, Israel 03 6120092, Italy 02 413091,
Japan 03 5472 2970, Korea 02 596 7456, Mexico 5 520 2635, Netherlands 0348 433466, Norway 32 84 84 00,
Singapore 2265886, Spain 91 640 0085, Sweden 08 730 49 70, Switzerland 056 200 51 51, Taiwan 02 377 1200,
United Kingdom 01635 523545

National Instruments Corporate Headquarters

6504 Bridge Point Parkway Austin, Texas 78730-5039 USA Tel: 512 794 0100

Important Information

Warranty

The DAQ-STC is warranted against defects in materials and workmanship for a period of one year from the date of shipment, as evidenced by receipts or other documentation. National Instruments will, at its option, repair or replace equipment that proves to be defective during the warranty period. This warranty includes parts and labor.

The media on which you receive National Instruments software are warranted not to fail to execute programming instructions, due to defects in materials and workmanship, for a period of 90 days from date of shipment, as evidenced by receipts or other documentation. National Instruments will, at its option, repair or replace software media that do not execute programming instructions if National Instruments receives notice of such defects during the warranty period. National Instruments does not warrant that the operation of the software shall be uninterrupted or error free.

A Return Material Authorization (RMA) number must be obtained from the factory and clearly marked on the outside of the package before any equipment will be accepted for warranty work. National Instruments will pay the shipping costs of returning to the owner parts which are covered by warranty.

National Instruments believes that the information in this document is accurate. The document has been carefully reviewed for technical accuracy. In the event that technical or typographical errors exist, National Instruments reserves the right to make changes to subsequent editions of this document without prior notice to holders of this edition. The reader should consult National Instruments if errors are suspected. In no event shall National Instruments be liable for any damages arising out of or related to this document or the information contained in it.

EXCEPT AS SPECIFIED HEREIN, NATIONAL INSTRUMENTS MAKES NO WARRANTIES, EXPRESS OR IMPLIED, AND SPECIFICALLY DISCLAIMS ANY WARRANTY OF MERCHANTABILITY OR FITNESS FOR A PARTICULAR PURPOSE. CUSTOMER'S RIGHT TO RECOVER DAMAGES CAUSED BY FAULT OR NEGLIGENCE ON THE PART OF NATIONAL INSTRUMENTS SHALL BE LIMITED TO THE AMOUNT THEREFORE PAID BY THE CUSTOMER. NATIONAL INSTRUMENTS WILL NOT BE LIABLE FOR DAMAGES RESULTING FROM LOSS OF DATA, PROFITS, USE OF PRODUCTS, OR INCIDENTAL OR CONSEQUENTIAL DAMAGES, EVEN IF ADVISED OF THE POSSIBILITY THEREOF. This limitation of the liability of National Instruments will apply regardless of the form of action, whether in contract or tort, including negligence.

Any action against National Instruments must be brought within one year after the cause of action accrues. National Instruments shall not be liable for any delay in performance due to causes beyond its reasonable control. The warranty provided herein does not cover damages, defects, malfunctions, or service failures caused by owner's failure to follow the National Instruments installation, operation, or maintenance instructions; owner's modification of the product; owner's abuse, misuse, or negligent acts; and power failure or surges, fire, flood, accident, actions of third parties, or other events outside reasonable control.

Copyright

Under the copyright laws, this publication may not be reproduced or transmitted in any form, electronic or mechanical, including photocopying, recording, storing in an information retrieval system, or translating, in whole or in part, without the prior written consent of National Instruments Corporation.

Trademarks

CVI™, DAQ-STC™, NI-DAQ™, and RTSI™ are trademarks of National Instruments Corporation.

Product and company names mentioned herein are trademarks or trade names of their respective companies.

WARNING REGARDING MEDICAL AND CLINICAL USE OF NATIONAL INSTRUMENTS PRODUCTS

National Instruments products are not designed with components and testing intended to ensure a level of reliability suitable for use in treatment and diagnosis of humans. Applications of National Instruments products involving medical or clinical treatment can create a potential for accidental injury caused by product failure, or by errors on the part of the user or application designer. Any use or application of National Instruments products for or involving medical or clinical treatment must be performed by properly trained and qualified medical personnel, and all traditional medical safeguards, equipment, and procedures that are appropriate in the particular situation to prevent serious injury or death should always continue to be used when National Instruments products are being used. National Instruments products are NOT intended to be a substitute for any form of established process, procedure, or equipment used to monitor or safeguard human health and safety in medical or clinical treatment.

Contents

About This Manual

Organization of This Manual	xxiii
Conventions Used in This Manual.....	xxv
National Instruments Documentation	xxvi
Related Documentation.....	xxvi
Customer Communication	xxvii

Chapter 1

Introduction

1.1 DAQ-STC Applications	1-2
1.1.1 Analog Input Application	1-2
1.1.2 Analog Output Application	1-3
1.2 DAQ-STC Block Diagram	1-4

Chapter 2

Analog Input Timing/Control

2.1 Overview	2-1
2.1.1 Programming the AITM	2-1
2.2 Features	2-2
2.3 Simplified Model.....	2-4
2.4 Analog Input Functions	2-6
2.4.1 Low-Level Timing and Control.....	2-6
2.4.1.1 ADC Control.....	2-7
2.4.1.2 Data FIFO Control	2-7
2.4.1.3 Configuration FIFO and External Multiplexer Control	2-7
2.4.1.4 CONVERT Timing	2-9
2.4.2 Scan-Level Timing and Control	2-11
2.4.2.1 Internal START Mode	2-11
2.4.2.2 External START Mode	2-12
2.4.3 Acquisition-Level Timing and Control	2-14
2.4.3.1 Posttrigger Acquisition Mode	2-14
2.4.3.2 Pretrigger Acquisition Mode	2-14
2.4.3.3 Continuous Acquisition Mode	2-15
2.4.3.4 Staged Acquisition	2-16
2.4.3.5 Master/Slave Trigger	2-16
2.4.4 Gating	2-16
2.4.4.1 Free-Run Gating Mode	2-17

	2.4.4.2	Halt-Gating Mode.....	2-17
	2.4.5	Single-Wire Mode.....	2-18
2.5		Pin Locator Interface.....	2-19
2.6		Programming Information	2-24
	2.6.1	Register and Bitfield Programming Considerations	2-24
	2.6.2	Windowing Registers.....	2-25
	2.6.3	Programming for an Analog Input Operation	2-25
	2.6.3.1	Resetting	2-26
	2.6.3.2	Board Power-up Initialization	2-27
	2.6.3.3	Initialize Configuration Memory Output.....	2-28
	2.6.3.4	Board Environment Setup	2-29
	2.6.3.5	FIFO Request.....	2-30
	2.6.3.6	Hardware Gate Programming	2-30
	2.6.3.7	Software Gate Operation	2-31
	2.6.3.8	Trigger Signals	2-32
	2.6.3.9	Number of Scans	2-33
	2.6.3.10	Start of Scan	2-34
	2.6.3.11	End of Scan.....	2-37
	2.6.3.12	Convert Signal	2-38
	2.6.3.13	Enable Interrupts	2-40
	2.6.3.14	Arming.....	2-41
	2.6.3.15	Starting the Acquisition.....	2-41
	2.6.3.16	Analog Input Program	2-42
	2.6.4	Single Scan.....	2-42
	2.6.5	Change Scan Rate during an Acquisition	2-43
	2.6.6	Staged Acquisition	2-44
	2.6.7	Master/Slave Operation Considerations.....	2-45
	2.6.8	Analog Input-Related Interrupts	2-46
	2.6.9	Bitfield Descriptions	2-48
2.7		Timing Diagrams	2-84
	2.7.1	Signal Definitions	2-84
	2.7.1.1	CONVERT_SRC.....	2-84
	2.7.1.2	OUT_CLK.....	2-85
	2.7.2	Basic Analog Input Timing.....	2-86
	2.7.3	Data FIFOs	2-88
	2.7.4	Configuration Memory	2-89
	2.7.5	Maximum Rate Analog Input	2-91
	2.7.6	External CONVERT Source	2-92
	2.7.7	External Triggers.....	2-93
	2.7.8	Trigger Output.....	2-97
	2.7.8.1	START1 and START2 Triggers	2-97
	2.7.8.2	START Trigger and SCAN_IN_PROG Assertion.....	2-100

	2.7.8.3	SCAN_IN_PROG Deassertion	2-103
	2.7.8.4	STOP Trigger.....	2-103
2.7.9		Counter Outputs.....	2-105
	2.7.9.1	SC_TC	2-105
	2.7.9.2	SI_TC.....	2-105
	2.7.9.3	DIV_TC	2-106
2.7.10		Macro-Level Analog Input Timing	2-106
2.7.11		External Gating.....	2-109
2.8		Detailed Description.....	2-112
2.8.1		Internal Signals and Operation	2-113
2.8.2		Trigger Selection and Conditioning	2-119
	2.8.2.1	Using Edge Detection	2-122
	2.8.2.2	Using Synchronization.....	2-122
	2.8.2.3	Trigger Signals.....	2-122
2.8.3		Analog Input Counters	2-123
	2.8.3.1	SC Counter.....	2-124
	2.8.3.2	SC Control	2-124
	2.8.3.3	SI Counter	2-126
	2.8.3.4	SI Control.....	2-126
	2.8.3.5	SI2 Counter	2-127
	2.8.3.6	SI2 Control.....	2-127
	2.8.3.7	DIV Counter	2-128
	2.8.3.8	DIV Control	2-129
2.8.4		Interrupt Control	2-130
2.8.5		Error Detection	2-132
	2.8.5.1	Overrun Error.....	2-132
	2.8.5.2	Overflow Error.....	2-132
	2.8.5.3	SC_TC Error.....	2-132
2.8.6		Nominal Signal Pulseswidths.....	2-133

Chapter 3

Analog Output Timing/Control

3.1		Overview	3-1
	3.1.1	Programming the AOTM	3-2
3.2		Features	3-2
3.3		Simplified Model.....	3-4
3.4		Analog Output Functions	3-5
	3.4.1	Primary Group Analog Output Modes	3-5
		3.4.1.1 DAQ-STC-Driven Analog Output.....	3-6
		3.4.1.2 CPU-Driven Analog Output	3-6
		3.4.1.3 DAQ-STC and CPU Conflict	3-7
	3.4.2	DAC Interface	3-8

3.4.3	Data Interfaces	3-8
3.4.3.1	FIFO Data Interface.....	3-8
3.4.3.2	Serial Link Data Interface	3-10
3.4.3.3	Unbuffered Data Interface.....	3-11
3.4.4	Update Timing for Primary Group Analog Output.....	3-11
3.4.4.1	Internal UPDATE.....	3-11
3.4.4.2	External UPDATE.....	3-12
3.4.5	Buffer Timing and Control for Primary Analog Output	3-12
3.4.5.1	Single-Buffer Mode.....	3-13
3.4.5.2	Continuous Mode	3-13
3.4.5.3	Waveform Staging.....	3-14
3.4.5.4	Mute Buffers.....	3-15
3.4.5.5	Master/Slave Trigger	3-15
3.4.6	Secondary Analog Output.....	3-16
3.5	Pin Interface	3-16
3.6	Programming Information	3-20
3.6.1	Programming for a Primary Analog Output Operation	3-20
3.6.1.1	Overview	3-21
3.6.1.2	Resetting	3-21
3.6.1.3	Board Power-up Initialization	3-22
3.6.1.4	Trigger Signals	3-23
3.6.1.5	Number of Buffers.....	3-24
3.6.1.6	Update Selection.....	3-26
3.6.1.7	Channel Select.....	3-28
3.6.1.8	LDAC Source and UPDATE Mode	3-29
3.6.1.9	Stop On Error	3-29
3.6.1.10	FIFO Mode	3-29
3.6.1.11	Enable Interrupts	3-30
3.6.1.12	Arming.....	3-30
3.6.1.13	Starting the Waveform	3-31
3.6.1.14	Primary Analog Output Program.....	3-31
3.6.2	Waveform Staging for Primary Analog Output.....	3-32
3.6.3	Changing Update Rate during an Output Operation for Primary Analog Output Group.....	3-34
3.6.4	Master/Slave Operation Considerations for Primary Analog Output Group	3-35
3.6.5	Primary Analog Output Group-Related Interrupts.....	3-35
3.6.6	Programming for a Secondary Analog Output Group Operation	3-38
3.6.6.1	Overview	3-38
3.6.6.2	Resetting	3-38
3.6.6.3	Board Power-up Initialization	3-39
3.6.6.4	Hardware Gate Programming	3-39
3.6.6.5	Software Gate Operation	3-40

	3.6.6.6	Counting for Waveform Staging.....	3-40
	3.6.6.7	Update Selection	3-40
	3.6.6.8	Arming	3-41
	3.6.6.9	Secondary Analog Output Program	3-41
3.6.7		Waveform Staging for Secondary Analog Output	3-42
3.6.8		Changing Update Rate during an Output Operation for Secondary Analog Output	3-44
3.6.9		Master/Slave Operation Considerations for Secondary Analog Output	3-45
3.6.10		Secondary Analog Output-Related Interrupts	3-45
3.6.11		Bitfield Descriptions.....	3-45
3.7		Timing Diagrams.....	3-84
3.7.1		Signal Definitions.....	3-84
	3.7.1.1	UPDATE_SRC	3-85
	3.7.1.1	UI2_SRC.....	3-85
	3.7.1.1	OUT_CLK	3-86
3.7.2		DAQ-STC-Driven Analog Output Timing.....	3-86
3.7.3		CPU-Driven Analog Output Timing	3-88
3.7.4		DAQ-STC- and CPU-Driven Analog Output Timing	3-90
3.7.5		Secondary Analog Output Timing.....	3-93
3.7.6		Decoded Signal Timing.....	3-94
3.7.7		Local Buffer Mode Timing	3-96
3.7.8		Unbuffered Data Interface Timing	3-98
3.7.9		Maximum Update Rate Timing.....	3-101
3.7.10		External Trigger Timing.....	3-102
3.7.11		Trigger Output.....	3-104
	3.7.11.1	START1 Trigger.....	3-104
3.7.12		Counter Outputs.....	3-107
	3.7.12.1	BC_TC	3-107
	3.7.12.2	UC_TC.....	3-108
3.8		Detailed Description.....	3-108
3.8.1		Internal Signals and Operation	3-109
3.8.2		Trigger Selection and Conditioning	3-114
	3.8.2.1	Using Edge Detection	3-116
	3.8.2.2	Using Synchronization.....	3-116
	3.8.2.3	Trigger Signals.....	3-116
3.8.3		Analog Output Counters.....	3-117
	3.8.3.1	UI Counter	3-117
	3.8.3.2	UI Control	3-118
	3.8.3.3	UC Counter	3-118
	3.8.3.4	UC Control.....	3-119
	3.8.3.5	BC Counter	3-120
	3.8.3.6	BC Control.....	3-120

3.8.3.7	UI2 Counter	3-121
3.8.3.8	UI2 Control.....	3-121
3.8.4	Interrupt Control	3-122
3.8.5	Error Detection.....	3-122
3.8.5.1	Overrun Error	3-122
3.8.5.2	BC_TC Error	3-123
3.8.5.3	BC_TC Trigger Error	3-123
3.8.5.4	UI2_TC Error	3-123
3.8.6	Output Control	3-123
3.8.7	Nominal Signal Pulsewidths	3-124

Chapter 4

General-Purpose Counter/Timer

4.1	Overview	4-1
4.1.1	Programming the GPCT.....	4-1
4.2	Features	4-1
4.3	Simplified Model	4-2
4.4	Counter/Timer Functions	4-3
4.4.1	Event Counting	4-3
4.4.1.1	Simple Event Counting.....	4-4
4.4.1.2	Simple Gated-Event Counting.....	4-4
4.4.1.3	Buffered Noncumulative Event Counting.....	4-4
4.4.1.4	Buffered Cumulative Event Counting	4-5
4.4.1.5	Relative Position Sensing	4-6
4.4.2	Time Measurement	4-6
4.4.2.1	Single-Period Measurement	4-6
4.4.2.2	Single-Pulsewidth Measurement	4-7
4.4.2.3	Buffered Period Measurement.....	4-7
4.4.2.4	Buffered Semiperiod Measurement.....	4-8
4.4.2.5	Buffered Pulsewidth Measurement	4-9
4.4.3	Pulse Generation	4-9
4.4.3.1	Single Pulse Generation	4-9
4.4.3.2	Single Triggered Pulse Generation.....	4-10
4.4.3.3	Retriggerable Single Pulse Generation.....	4-11
4.4.3.4	Buffered Retriggerable Single Pulse Generation	4-11
4.4.4	Pulse-Train Generation	4-12
4.4.4.1	Continuous Pulse-Train Generation	4-12
4.4.4.2	Buffered Static Pulse-Train Generation	4-13
4.4.4.3	Buffered Pulse-Train Generation	4-14
4.4.4.4	Frequency Shift Keying (FSK).....	4-14
4.4.4.5	Pulse Generation for ETS	4-15
4.5	Pin Interface	4-16

4.6	Programming Information.....	4-17
4.6.1	Programming for a GPCT Operation	4-17
4.6.1.1	Overview.....	4-17
4.6.1.2	Notation	4-18
4.6.1.3	Resetting	4-18
4.6.1.4	Arming	4-18
4.6.1.5	Simple Event Counting	4-19
4.6.1.6	Buffered Event Counting	4-20
4.6.1.7	Relative Position Sensing	4-23
4.6.1.8	Single-Period and Pulsewidth Measurement	4-24
4.6.1.9	Buffered Period, Semiperiod, and Pulsewidth Measurement.....	4-26
4.6.1.10	Pulse and Continuous Pulse-Train Generation	4-28
4.6.1.11	Frequency Shift Keying	4-31
4.6.1.12	Pulse-Train Generation for ETS	4-33
4.6.1.13	Reading the Counter Contents	4-34
4.6.1.14	Reading the Hardware Save Registers.....	4-34
4.6.1.15	Enabling the General Purpose Counter/Timer Output Pin	4-35
4.6.2	Bitfield Descriptions.....	4-35
4.7	Timing Diagrams.....	4-53
4.7.1	CTRSRC Minimum Period and Minimum Pulsewidth.....	4-55
4.7.2	CTRSRC to CTROUT Delay	4-55
4.7.3	G_GATE Minimum Pulsewidth.....	4-56
4.7.4	CTRGATE to CTROUT Delay	4-57
4.7.5	CTRGATE to INTERRUPT.....	4-57
4.7.6	CTRGATE Setup.....	4-58
4.7.7	CTR_U/D Setup	4-59
4.8	Detailed Description.....	4-61
4.8.1	Internal Signals and Operation	4-62
4.8.2	G_SOURCE Selection and Conditioning.....	4-63
4.8.3	G_GATE Selection and Conditioning.....	4-64
4.8.4	G_UP_DOWN Control	4-64
4.8.5	G_OUT Conditioning and Routing	4-65
4.8.6	G_CONTROL Conditioning	4-67
4.8.7	Gate Actions	4-67
4.8.7.1	START/STOP on G_CONTROL	4-68
4.8.7.2	Save on G_GATE	4-68
4.8.7.3	Reload on G_CONTROL	4-68
4.8.7.4	UP/DOWN on G_CONTROL	4-69
4.8.7.5	Generate Interrupt on G_GATE.....	4-69
4.8.7.6	Change Output Polarity on G_GATE.....	4-69
4.8.7.7	Select Load Register on G_CONTROL	4-69

4.8.7.8	Disarm Counter on G_CONTROL.....	4-70
4.8.7.9	Switch Load Bank Selection on G_CONTROL.....	4-70
4.8.8	Interrupt Control	4-70
4.8.9	PFI Selection	4-70
4.8.10	Error Detection.....	4-71
4.8.10.1	Gate Acknowledge Latency Error	4-71
4.8.10.2	Stale Data Error	4-71
4.8.10.3	Permanent Stale Data Error	4-71
4.8.10.4	TC Latency Error.....	4-72
4.8.11	Detailed Operation by Application	4-72
4.8.11.1	Simple Event Counting.....	4-72
4.8.11.2	Simple Gated-Event Counting.....	4-73
4.8.11.3	Buffered Noncumulative-Event Counting.....	4-74
4.8.11.4	Buffered Cumulative-Event Counting.....	4-74
4.8.11.5	Relative-Position Sensing.....	4-75
4.8.11.6	Single-Period Measurement	4-76
4.8.11.7	Single Pulswidth Measurement	4-77
4.8.11.8	Buffered Period Measurement.....	4-78
4.8.11.9	Buffered Semiperiod Measurement.....	4-79
4.8.11.10	Buffered Pulswidth Measurement	4-80
4.8.11.11	Single Pulse Generation	4-81
4.8.11.12	Single-Triggered Pulse Generation	4-82
4.8.11.13	Retriggerable Single Pulse Generation.....	4-83
4.8.11.14	Continuous Pulse-Train Generation	4-84
4.8.11.15	Buffered Pulse-Train Generation	4-85
4.8.11.16	Frequency Shift Keying.....	4-86
4.8.11.17	Pulse Generation for ETS.....	4-87

Chapter 5

Programmable Function Inputs

5.1	Overview.....	5-1
5.2	Features	5-1
5.3	Pin Interface	5-2
5.4	Programming Information	5-5
5.4.1	Programming the PFI Pins	5-5
5.4.2	Bitfield Descriptions	5-6
5.5	Detailed Description	5-7

Chapter 6

RTSI Trigger

6.1	Overview.....	6-1
6.2	Features	6-1

6.3	Pin Interface	6-1
6.4	Programming Information	6-2
6.4.1	Programming the RTSI Interface	6-2
6.4.2	Bitfield Descriptions.....	6-3
6.5	Detailed Description.....	6-6

Chapter 7

Digital I/O

7.1	Overview	7-1
7.2	Features	7-1
7.3	Simplified Model.....	7-1
7.4	Overview of DIO Functions	7-2
7.4.1	Parallel Mode.....	7-2
7.4.1.1	Parallel Input.....	7-3
7.4.1.2	Parallel Output	7-3
7.4.2	Serial Mode	7-4
7.4.2.1	Serial Input.....	7-4
7.4.2.2	Serial Output.....	7-4
7.4.2.3	Serial I/O.....	7-5
7.5	Pin Interface	7-6
7.6	Programming Information	7-7
7.6.1	Windowed Mode Register Access Example	7-7
7.6.2	Programming the Digital Interface.....	7-8
7.6.2.1	Parallel Digital I/O.....	7-9
7.6.2.2	Hardware-Controlled Serial Digital I/O.....	7-10
7.6.2.3	Software-Controlled Serial Digital I/O.....	7-12
7.6.2.4	Programming the Control Lines	7-12
7.6.2.5	Reading the Status Lines.....	7-13
7.6.3	Bitfield Descriptions.....	7-13
7.7	Timing Diagrams.....	7-15
7.7.1	Serial Input Timing.....	7-15
7.7.2	Serial Output Timing.....	7-16
7.8	Detailed Description.....	7-17

Chapter 8

Interrupt Control

8.1	Overview	8-1
8.2	Features	8-1
8.3	Pin Interface	8-2
8.4	Programming Information.....	8-3
8.4.1	Programming the Interrupt Interface.....	8-3
8.4.1.1	Interrupt Output Polarity.....	8-3

	8.4.1.2	Interrupt Output Select and Enable	8-3
	8.4.1.3	Pass-Through Interrupt	8-4
8.4.2		Interrupt Handling	8-5
	8.4.2.1	Interrupt Program	8-6
	8.4.2.2	Interrupt Group A	8-6
	8.4.2.3	Interrupt Group B	8-9
8.4.3		Bitfield Descriptions	8-12
8.5		Interrupt Conditions	8-15

Chapter 9 Bus Interface

9.1		Overview	9-1
9.2		Features	9-1
	9.2.1	Pin Interface	9-1
9.3		Programming Information	9-3
	9.3.1	Programming the Write Strobes	9-4
	9.3.2	Bitfield Descriptions	9-4
9.4		Timing Diagrams	9-5

Chapter 10 Miscellaneous Functions

10.1		Overview	10-1
10.2		Features	10-1
10.3		Clock Distribution	10-2
10.4		Frequency Output	10-3
10.5		Analog Trigger	10-3
10.6		Test Mode	10-6
10.7		Pin Interface	10-9
10.8		Programming Information	10-10
	10.8.1	Programming Clock Distribution	10-10
	10.8.2	Programming FOUT	10-12
	10.8.3	Programming Analog Trigger	10-12
	10.8.4	Bitfield Descriptions	10-12

Appendix A Specifications

Appendix B Register Information

Appendix C Pin List

Appendix D DAQ-STC Revision History

Appendix E Customer Communication

Glossary

Index

Figures

Figure 1-1.	Analog Input Application.....	1-2
Figure 1-2.	Analog Output Application.....	1-3
Figure 1-3.	DAQ-STC Block Diagram.....	1-4
Figure 2-1.	Typical Analog Input Waveform.....	2-4
Figure 2-2.	AITM Simplified Model.....	2-5
Figure 2-3.	ADC Control.....	2-7
Figure 2-4.	Configuration FIFO Control.....	2-8
Figure 2-5.	External Multiplexer Control.....	2-9
Figure 2-6.	Internal CONVERT Timing.....	2-10
Figure 2-7.	External CONVERT Timing.....	2-11
Figure 2-8.	Internal START.....	2-12
Figure 2-9.	External START.....	2-13
Figure 2-10.	SI Special Trigger Delay.....	2-13
Figure 2-11.	Posttrigger Acquisition Mode.....	2-14
Figure 2-12.	Pretrigger Acquisition Mode.....	2-15
Figure 2-13.	Free-Run Gating Mode.....	2-17
Figure 2-14.	Halt-Gating Mode.....	2-18
Figure 2-15.	Single-Wire Mode.....	2-18
Figure 2-16.	Basic Analog Input Timing.....	2-86
Figure 2-17.	Data FIFO Timing.....	2-88
Figure 2-18.	Configuration Memory Timing.....	2-89
Figure 2-19.	Maximum Rate Analog Input Timing.....	2-92
Figure 2-20.	External CONVERT_SRC Timing.....	2-93
Figure 2-21.	External Trigger Timing, Asynchronous Level.....	2-94

Figure 2-22.	External Trigger Timing, Asynchronous Edge	2-94
Figure 2-23.	External Trigger Timing, Synchronous Level, Internal CONVERT Mode	2-95
Figure 2-24.	External Trigger Timing, Synchronous Edge, Internal CONVERT Mode	2-95
Figure 2-25.	External Trigger Timing, Synchronous Level, External CONVERT Mode	2-96
Figure 2-26.	External Trigger Timing, Synchronous Edge, External CONVERT Mode	2-96
Figure 2-27.	START1 Delays, Synchronous Mode, Internal CONVERT	2-98
Figure 2-28.	START2 Delays, Synchronous Mode, Internal CONVERT	2-98
Figure 2-29.	START1 Delays, Synchronous Mode, External CONVERT	2-98
Figure 2-30.	START2 Delays, Synchronous Mode, External CONVERT	2-99
Figure 2-31.	START1 Delays, Asynchronous Mode	2-99
Figure 2-32.	START2 Delays, Asynchronous Mode	2-100
Figure 2-33.	START Delays, Internal CONVERT	2-101
Figure 2-34.	START Delays, External CONVERT	2-102
Figure 2-35.	SCAN_IN_PROG Deassertion	2-103
Figure 2-36.	STOP Delay, Synchronous Mode	2-104
Figure 2-37.	STOP Delay, Asynchronous Mode	2-104
Figure 2-38.	SC_TC Delay	2-105
Figure 2-39.	SI_TC Delay	2-105
Figure 2-40.	DIV_TC Delay	2-106
Figure 2-41.	Interval Scanning Mode Timing	2-106
Figure 2-42.	Free-Run Gating Mode Timing, Internal CONVERT	2-109
Figure 2-43.	Free-Run Gating Mode Timing, External CONVERT	2-110
Figure 2-44.	Halt-Gating Mode Timing, Internal CONVERT	2-111
Figure 2-45.	AITM Block Diagram	2-112
Figure 2-46.	START and STOP Routing Logic	2-120
Figure 2-47.	START1 and START2 Routing Logic	2-120
Figure 2-48.	EXT_GATE Routing Logic	2-121
Figure 2-49.	SC Control Circuit State Transitions	2-125
Figure 2-50.	SI Control Circuit State Transitions	2-127
Figure 2-51.	SI2 Control Circuit State Transitions	2-128
Figure 2-52.	DIV Control Circuit State Transitions	2-130
Figure 3-1.	AOTM Simplified Mode	3-4
Figure 3-2.	DAQ-STC-Driven Analog Output	3-6
Figure 3-3.	CPU-Driven Analog Output	3-7
Figure 3-4.	DAQ-STC and CPU Conflict	3-7
Figure 3-5.	FIFO Data Interface	3-9
Figure 3-6.	Local Buffer Mode	3-10
Figure 3-7.	Serial Link Data Interface	3-10

Figure 3-8.	Unbuffered Data Interface.....	3-11
Figure 3-9.	Internal UPDATE Timing	3-12
Figure 3-10.	External UPDATE Timing	3-12
Figure 3-11.	Single-Buffer Mode.....	3-13
Figure 3-12.	Continuous Mode	3-14
Figure 3-13.	Mute Buffers.....	3-15
Figure 3-14.	DAQ-STC-Driven Analog Output Timing.....	3-87
Figure 3-15.	CPU-Driven Analog Output Timing	3-89
Figure 3-16.	Analog Output Contention Timing, Case A.....	3-91
Figure 3-17.	Analog Output Contention Timing, Case B	3-92
Figure 3-18.	Secondary Analog Output Timing	3-93
Figure 3-19.	Decoded Signal Timing.....	3-95
Figure 3-20.	Local Buffer Mode Timing	3-97
Figure 3-21.	Unbuffered Data Interface Timing	3-99
Figure 3-22.	Maximum Update Rate Timing.....	3-101
Figure 3-23.	External Trigger, Asynchronous Level	3-102
Figure 3-24.	External Trigger, Asynchronous Edge	3-102
Figure 3-25.	External Trigger, Synchronous Level, Internal UPDATE Mode.....	3-103
Figure 3-26.	External Trigger, Synchronous Edge, Internal UPDATE Mode.....	3-103
Figure 3-27.	External Trigger, Synchronous Level, External UPDATE Mode.....	3-103
Figure 3-28.	External Trigger, Synchronous Edge, External UPDATE Mode.....	3-103
Figure 3-29.	START1 Delays, Synchronous Mode, Internal UPDATE.....	3-105
Figure 3-30.	START1 Delays, Synchronous Mode, External UPDATE.....	3-106
Figure 3-31.	START1 Delays, Asynchronous Mode.....	3-107
Figure 3-32.	BC_TC Delay	3-107
Figure 3-33.	UC_TC Delay.....	3-108
Figure 3-34.	AOTM Block Diagram.....	3-109
Figure 3-35.	START1 Routing Logic	3-115
Figure 3-36.	EXT_GATE and EXT_GATE2 Routing Logic	3-115
Figure 3-37.	UI Control Circuit State Transitions	3-118
Figure 3-38.	UC Control Circuit State Transitions	3-119
Figure 3-39.	BC Control Circuit State Transitions	3-121
Figure 4-1.	General-Purpose Counter/Timer Simplified Model	4-2
Figure 4-2.	Simple Event Counting	4-4
Figure 4-3.	Simple Gated-Event Counting.....	4-4
Figure 4-4.	Buffered Noncumulative Event Counting.....	4-5
Figure 4-5.	Cumulative Event Counting	4-5
Figure 4-6.	Relative Position Sensing.....	4-6
Figure 4-7.	Single-Period Measurement	4-7
Figure 4-8.	Single-Pulsewidth Measurement.....	4-7
Figure 4-9.	Buffered Period Measurement.....	4-8
Figure 4-10.	Buffered Semiperiod Measurement.....	4-8

Figure 4-11.	Buffered Pulsewidth Measurement.....	4-9
Figure 4-12.	Single Pulse Generation.....	4-10
Figure 4-13.	Single Triggered-Pulse Generation.....	4-10
Figure 4-14.	Retriggerable Single Pulse Generation.....	4-11
Figure 4-15.	Buffered Retriggerable Single Pulse Generation.....	4-12
Figure 4-16.	Continuous Pulse-Train Generation.....	4-13
Figure 4-17.	Buffered Static Pulse-Train Generation.....	4-13
Figure 4-18.	Buffered Pulse-Train Generation.....	4-14
Figure 4-19.	Frequency Shift Keying.....	4-15
Figure 4-20.	Pulse Generation for ETS.....	4-15
Figure 4-21.	CTRSRC Minimum Period and Minimum Pulsewidth.....	4-55
Figure 4-22.	CTRSRC to CTROUT Timing.....	4-56
Figure 4-23.	G_GATE Minimum Pulsewidth.....	4-56
Figure 4-24.	CTRGATE to CTROUT Timing.....	4-57
Figure 4-25.	CTRGATE to INTERRUPT Timing.....	4-57
Figure 4-26.	CTRGATE Setup Timing, Internal Timing Mode.....	4-58
Figure 4-27.	CTRGATE Setup Timing, External Timing Mode.....	4-59
Figure 4-28.	CTR_U/D Setup Timing, Internal Timing Mode.....	4-60
Figure 4-29.	CTR_U/D Setup Timing, External Timing Mode.....	4-60
Figure 4-30.	General-Purpose Counter/Timer Model.....	4-61
Figure 4-31.	G_SOURCE Generation.....	4-72
Figure 4-32.	Simple Event Counting.....	4-73
Figure 4-33.	Simple Gated-Event Counting.....	4-73
Figure 4-34.	Buffered Noncumulative-Event Counting.....	4-74
Figure 4-35.	Buffered Cumulative-Event Counting.....	4-75
Figure 4-36.	Relative-Position Sensing.....	4-75
Figure 4-37.	Single-Period Measurement.....	4-76
Figure 4-38.	Single Pulsewidth Measurement.....	4-77
Figure 4-39.	Buffered Period Measurement.....	4-78
Figure 4-40.	Buffered Semiperiod Measurement.....	4-79
Figure 4-41.	Buffered Pulsewidth Measurement.....	4-80
Figure 4-42.	Single Pulse Generation.....	4-81
Figure 4-43.	Single-Triggered Pulse Generation.....	4-82
Figure 4-44.	Retriggerable Single Pulse Generation.....	4-83
Figure 4-45.	Continuous Pulse-Train Generation.....	4-84
Figure 4-46.	Buffered Pulse-Train Generation.....	4-85
Figure 4-47.	Frequency Shift Keying.....	4-86
Figure 4-48.	Pulse Generation for ETS.....	4-87
Figure 7-1.	DIO Simplified Model.....	7-2
Figure 7-2.	Parallel Input.....	7-3
Figure 7-3.	Parallel Output.....	7-3
Figure 7-4.	DIO Serial Input.....	7-4

Figure 7-5.	Serial Output.....	7-5
Figure 7-6.	Serial I/O	7-5
Figure 7-7.	Serial Input Timing	7-16
Figure 7-8.	Serial Output Timing.....	7-16
Figure 9-1.	Intel Bus Interface Read Timing	9-6
Figure 9-2.	Intel Bus Interface Write Timing	9-6
Figure 9-3.	Motorola Bus Interface Read Timing.....	9-7
Figure 9-4.	Motorola Bus Interface Write Timing.....	9-8
Figure 10-1.	Clock Distribution	10-2
Figure 10-2.	Low-Window Mode	10-4
Figure 10-3.	High-Window Mode.....	10-4
Figure 10-4.	Middle-Window Mode	10-5
Figure 10-5.	High-Hysteresis Mode.....	10-5
Figure 10-6.	Low-Hysteresis Mode	10-6
Figure 10-7.	Test Mode Internal Gate Tree	10-7

Tables

Table 2-1.	Pin Interface	2-19
Table 2-2.	CONVERT_SRC Reference Pin Selection	2-84
Table 2-3.	Basic Analog Input Timing	2-86
Table 2-4.	Configuration Memory Timing	2-90
Table 2-5.	External Analog Input Timing	2-96
Table 2-6.	START1 and START2 Timing, Synchronous Mode	2-99
Table 2-7.	START1 and START2 Timing, Asynchronous Mode	2-100
Table 2-8.	Interval Scanning Mode Timing	2-107
Table 2-9.	Internal Signals	2-113
Table 2-10.	PFI Selectors.....	2-121
Table 2-11.	Analog Input Interrupts	2-131
Table 2-12.	Analog Input Nominal Signal Widths	2-133
Table 3-1.	Pin Interface	3-16
Table 3-2.	UPDATE_SRC Reference Pin Selection	3-85
Table 3-3.	UI2_SRC Reference Pin Selection	3-85
Table 3-4.	DAQ-STC-Driven Analog Output Timing	3-87
Table 3-5.	External Trigger Timing.....	3-104
Table 3-6.	Internal Signals	3-109
Table 3-7.	PFI Selectors	3-115
Table 3-8.	Analog Output Interrupts	3-122
Table 3-9.	Analog Output Nominal Signal Widths	3-124

Table 4-1.	CTRSRC Reference Pin Selection.....	4-53
Table 4-2.	CTRGATE Reference Pin Selection	4-54
Table 4-3.	CTR_U/D Reference Pin Selection	4-54
Table 4-4.	Internal Signal Description	4-62
Table 4-5.	G_SOURCE Selection	4-63
Table 4-6.	G_SOURCE Conditioning.....	4-63
Table 4-7.	G_GATE Selection	4-64
Table 4-8.	G_GATE Conditioning.....	4-64
Table 4-9.	G_UP_DOWN Modes	4-65
Table 4-10.	G_OUT Mode	4-65
Table 4-11.	G_OUT Polarity.....	4-65
Table 4-12.	G_OUT0/RTSI_IO Selection.....	4-66
Table 4-13.	G_OUT1/DIV_TC_OUT Selection	4-66
Table 4-14.	G_CONTROL Conditioning.....	4-67
Table 4-15.	Gate Actions	4-67
Table 4-16.	START/STOP Modes for Edge Gating	4-68
Table 4-17.	Reload on G_CONTROL Selections	4-68
Table 4-18.	Gate Interrupts	4-69
Table 4-19.	PFI Selectors	4-70
Table 5-1.	Pin Interface	5-2
Table 5-2.	PFI<0..9> Input Selections	5-7
Table 5-3.	PFI<0..9> Output Selections.....	5-8
Table 6-1.	Pin Interface	6-2
Table 6-2.	RTSI_TRIGGER<0..6> Output Selections.....	6-6
Table 6-3.	RTSI_BRD<0..1> Output Selections.....	6-7
Table 6-4.	RTSI_BRD<2..3> Output Selections.....	6-7
Table 7-1.	Pin Interface	7-6
Table 7-2.	Serial Output Source Select	7-17
Table 8-1.	Pin Interface	8-2
Table 8-2.	Interrupt Condition Summary	8-15
Table 9-1.	Pin Interface	9-2
Table 9-2.	Intel Bus Interface Timing	9-6
Table 9-3.	Intel Bus Interface Timing	9-8
Table 10-1.	Timebases Derived from IN_TIMEBASE	10-2
Table 10-2.	Test Mode Input Pin Pairs	10-8
Table 10-3.	Pin Interface	10-9

Table B-1.	DAQ-STC Registers	B-1
Table B-2.	Registers in Order of Address*	B-5
Table B-3.	Bitfield Description Guide	B-9
Table C-1.	DAQ-STC Pins in Alphabetical Order	C-1
Table C-2.	Summary of Buffer Types	C-7

About This Manual

The DAQ-STC is an application-specific integrated circuit (ASIC) designed by National Instruments. The *DAQ-STC Technical Reference Manual* describes the programmable features of the DAQ-STC and is intended for programmers who need to program the DAQ-STC on an existing data acquisition (DAQ) board and for hardware engineers who want to design a DAQ board using the DAQ-STC.

Before using this manual to program the DAQ-STC on an existing board, you should be familiar with the board that contains your DAQ-STC. You should begin by reading the user manual for the board containing the DAQ-STC. Next, read the register-level programmer manual for the same board. The register-level programmer manual refers to some of the sections in this manual.

When you are familiar with the material in the register-level programmer manual, you can refer directly to the *DAQ-STC Technical Reference Manual*. Programmers should have to read only the *Programming Information* section of each chapter in order to program the DAQ-STC. Hardware engineers may need to read further for more detailed information about hardware operation.

Organization of This Manual

The *DAQ-STC Technical Reference Manual* is organized as follows:

- Chapter 1, *Introduction*, describes the data acquisition system timing controller (DAQ-STC), an application-specific integrated circuit (ASIC) for the system timing requirements of a general-purpose A/D and D/A system, such as a system containing the National Instruments multifunction I/O boards.
- Chapter 2, *Analog Input Timing/Control*, describes the analog input timing/control module (AITM), which generates timing for the ADC and controls signals for the associated circuitry.
- Chapter 3, *Analog Output Timing/Control*, describes the analog output timing/control module (AOTM), which generates timing for the DACs and controls signals for the associated circuitry, such as the data FIFO buffers.

- Chapter 4, *General-Purpose Counter/Timer*, presents information about the general-purpose counter/timer (GPCT) module of the DAQ-STC.
- Chapter 5, *Programmable Function Inputs*, explains the PFI module on the DAQ-STC.
- Chapter 6, *RTSI Trigger*, describes the features of the RTSI trigger module (RTM) and explains how to program the RTSI interface.
- Chapter 7, *Digital I/O*, describes the digital I/O (DIO) module and explains how to use it on the DAQ-STC.
- Chapter 8, *Interrupt Control*, describes the interrupt control module (ICM), its features, and the conditions that cause interrupts.
- Chapter 9, *Bus Interface*, describes the features of the bus interface module, gives programming instructions, and presents the timing diagrams for the bus interface.
- Chapter 10, *Miscellaneous Functions*, discusses the miscellaneous functions not covered in the other chapters. The miscellaneous functions include clock distribution, the programmable frequency output, analog triggering, and test mode.
- Appendix A, *Specifications*, contains specifications for the DAQ-STC.
- Appendix B, *Register Information*, contains information about the DAQ-STC registers and bitfields.
- Appendix C, *Pin List*, contains lists of the DAQ-STC pins.
- Appendix D, *DAQ-STC Revision History*, lists the differences between the first two revisions of the DAQ-STC and identifies those boards containing the first revision of the DAQ-STC.
- Appendix E, *Customer Communication*, contains forms you can use to request help from National Instruments or to comment on our products and manuals.
- The *Glossary* contains an alphabetical list and description of terms used in this manual, including abbreviations, acronyms, metric prefixes, mnemonics, and symbols.
- The *Index* contains an alphabetical list of key terms and topics in this manual, including the page where you can find each one.

Conventions Used in This Manual

The following conventions are used in this manual:

<>

Angle brackets containing numbers separated by an ellipsis represent a range of values associated with a bit or signal name—for example, ACH<0..7> stands for ACH0 through ACH7.



This icon to the left of bold italicized text denotes a note, which alerts you to important information.



This icon to the left of bold italicized text denotes a caution, which advises you of precautions to take to avoid injury, data loss, or a system crash.



This icon to the left of bold italicized text denotes a warning, which advises you of precautions to take to avoid being electrically shocked.

bold

Bold text denotes the names of menu items, or dialog box buttons or options.

bold italic

Bold italic text denotes a note, caution, or warning.

device

Device refers to any hardware that contains DAQ-STC.

italic

Italic text denotes emphasis, a cross reference, or an introduction to a key concept.

module

Module refers to each functional group in the DAQ-STC, as shown in Figure 1-3, *DAQ-STC Block Diagram*.

monospace

Text in this font denotes text or characters that you should literally enter from the keyboard, sections of code, programming examples, and syntax examples. This font is also used for the proper names of disk drives, paths, directories, programs, subprograms, subroutines, device names, functions, operations, variables, filenames and extensions, and for statements and comments taken from programs.

National Instruments Documentation

The *DAQ-STC Technical Reference Manual* is one piece of the documentation set for your data acquisition system. You could have any of several types of manuals depending on the hardware and software in your system. Use the manuals you have as follows:

- *Getting Started with SCXI*—If you are using SCXI, this is the first manual you should read. It gives an overview of the SCXI system and contains the most commonly needed information for the modules, chassis, and software.
- Your SCXI hardware user manuals—If you are using SCXI, read these manuals next for detailed information about signal connections and module configuration. They also explain in greater detail how the module works and contain application hints.
- Your DAQ hardware user manuals—These manuals have detailed information about the DAQ hardware that plugs into or is connected in your computer. Use these manuals for hardware installation and configuration instructions, specification information about your DAQ hardware, and application hints.
- Software manuals—Examples of software manuals you may have are the LabVIEW and LabWindows/CVI manual sets and the NI-DAQ manuals. After you set up your hardware system, use either the application software (LabVIEW or LabWindows/CVI) manuals or the NI-DAQ manuals to help you write your application. If you have a large and complicated system, it is worthwhile to look through the software manuals before you configure your hardware.
- Accessory manuals—If you are using accessory products, read the terminal block and cable assembly installation guides. They explain how to physically connect the relevant pieces of the system. Consult these guides when you are making your connections.
- SCXI chassis manuals—If you are using SCXI, read these manuals for maintenance information on the chassis and installation instructions.

Related Documentation

The following National Instruments documents contain general information and operating instructions for the DAQ-STC:

- *The AT E Series Register-Level Programmer Manual*
- *The AT E Series User Manual*

- *PCI E Series Register-Level Programmer Manual*
- *Application Note 010: Programming Interrupts for Data Acquisition on 80x86-Based Computers*

Customer Communication

National Instruments wants to receive your comments on our products and manuals. We are interested in the applications you develop with our products, and we want to help if you have problems with them. To make it easy for you to contact us, this manual contains comment and configuration forms for you to complete. These forms are in Appendix E, *Customer Communication*, at the end of this manual.

Introduction

This chapter describes the data acquisition system timing controller (DAQ-STC), an application-specific integrated circuit (ASIC) for the system timing requirements of a general-purpose A/D and D/A system, such as a system containing the National Instruments multifunction I/O (MIO) boards.

The DAQ-STC contains nine modules, or function groups. These function groups include the analog input timing/control module, analog output timing/control module, general-purpose counter/timer module, programmable function inputs module, RTSI trigger module, digital I/O module, interrupt control module, bus interface module, and the miscellaneous functions module.

The counters and support logic within the analog input timing/control and analog output timing/control modules supply timing and control signals to independent A/D and D/A subsystems.

Two counters in the general-purpose counter/timer module implement event-counting, time-measurement, and pulse-generation functions, and supply timing and trigger signals to the other modules.

The programmable function inputs and RTSI trigger modules have internal multiplexers to route signals among the DAQ-STC and the RTSI and I/O connectors so that you can operate the board with external timing and trigger signals, or you can output internally generated timing and trigger signals to either connector.

The digital I/O module enables you to transfer serial and parallel data between the CPU and an external device.

The interrupt control module simplifies software design by routing both board-level and internally generated interrupts to the CPU subsystem, and the bus interface module enables the DAQ-STC to communicate easily with most computer buses.

Finally, the miscellaneous functions module provides extra features such as clock distribution, the programmable frequency output, and analog triggering.

1.1 DAQ-STC Applications

The primary function of the DAQ-STC is to provide timing and control for the A/D and D/A subsystems of a DAQ board. To understand the DAQ-STC, you should be familiar with a typical implementation of an A/D and D/A board. This section presents a typical implementation of these two primary functions and familiarizes you with the components controlled by the DAQ-STC. The remaining functions, such as digital I/O and general-purpose counting, are self-contained and independent and can, therefore, be understood without discussing any specific implementation.

1.1.1 Analog Input Application

Figure 1-1 shows the primary components of an analog input subsystem. On an analog input board, a sample/hold circuit samples the analog value of one or more input channels, and an A/D converter (ADC) converts the analog value to a digital value. A FIFO then holds the digital data until it can be transferred to the host system memory.

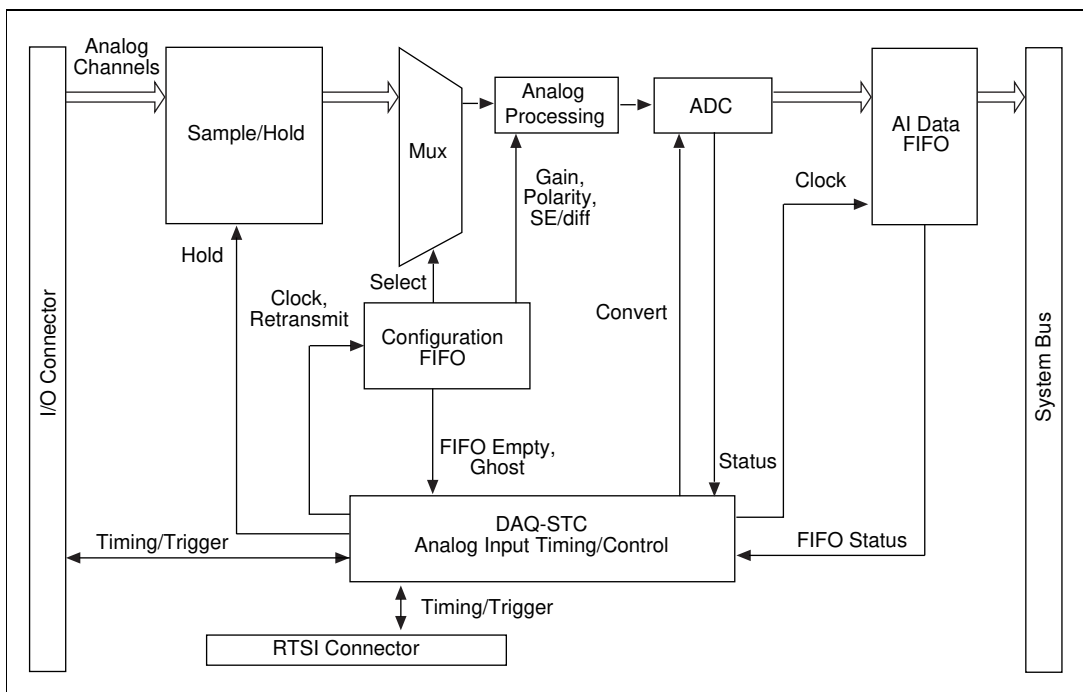

Figure 1-1. Analog Input Application

The analog channels enter the board through the I/O connector, as shown at the left of the figure. The DAQ-STC supplies a hold command to latch the analog values at the sample/hold device. On boards with multiple-input channels, a multiplexer selects each channel, one at a

time, and applies its voltage to the ADC. The DAQ-STC instructs the ADC to begin the conversion and monitors the progress through status flags. When the conversion is complete, the DAQ-STC clocks the digital data into the AI data FIFO until it can be retrieved by the system bus.

The DAQ-STC monitors the status of the AI data FIFO so that the DAQ-STC can generate an interrupt or a DMA request when the FIFO fills beyond a programmable threshold. On many boards, a configuration FIFO is available to provide gain control and channel selection. The DAQ-STC supplies a clock and a retransmit signal for the configuration FIFO and monitors the FIFO empty flag. The ghost signal from the configuration FIFO inhibits the AI data FIFO clock to provide a multirate sampling capability. Timing and trigger signals pass to and from the DAQ-STC and the I/O and RTSI connectors for external timing applications.

1.1.2 Analog Output Application

Figure 1-2 shows the primary components of an analog output subsystem. On an analog output board, the CPU typically writes the output data into the AO data FIFO, and one or more D/A converters (DACs) subsequently convert the digital data to an analog form.

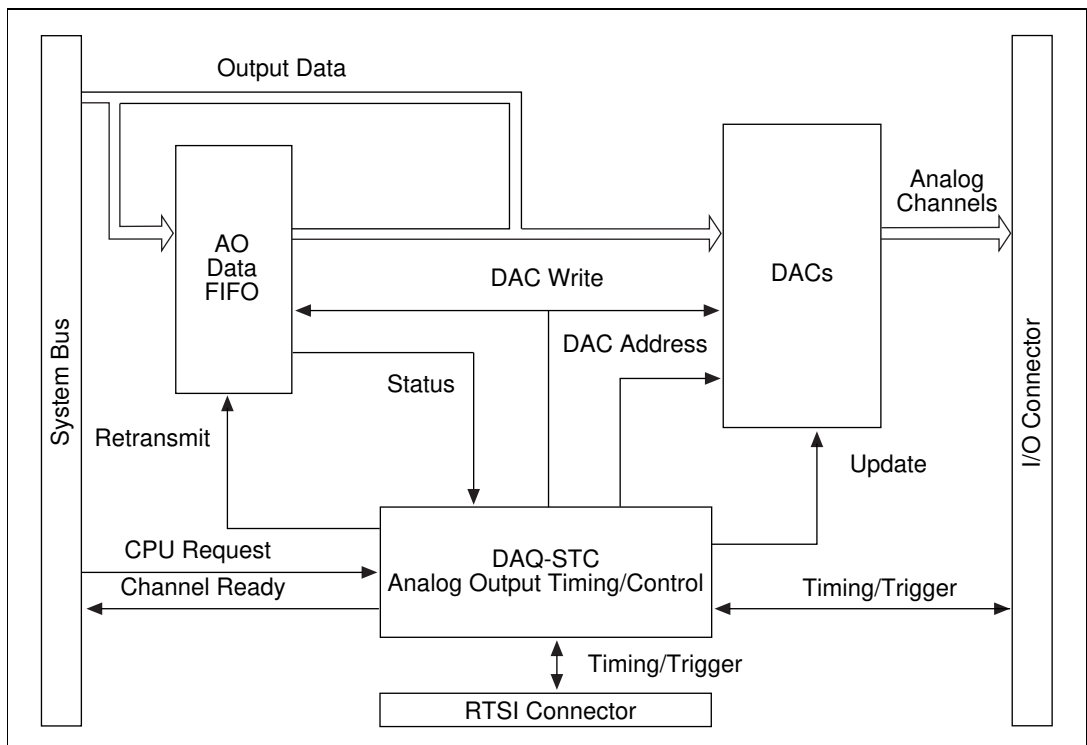

Figure 1-2. Analog Output Application

The DAQ-STC monitors the status of the AO data FIFO so that it can generate an interrupt or a DMA request when the FIFO empties beyond a programmable threshold. The DAQ-STC can also supply a retransmit signal to the AO data FIFO if the FIFO is large enough to hold the entire buffer. When the output data is needed at the converters, the DAQ-STC clocks the data from the FIFO into the DACs using the DAC write and DAC address signals. An update signal allows all of the DACs to update their outputs simultaneously.

The CPU can also write directly to the DACs, using the CPU request signal to request that the DAQ-STC allow access. The DAQ-STC arbitrates between itself and the CPU, notifying the CPU that the write has completed using the channel ready signal. Timing and trigger signals pass to and from the DAQ-STC and the I/O and RTSI connectors for external timing applications.

1.2 DAQ-STC Block Diagram

Figure 1-3 shows a block diagram of the DAQ-STC. The diagram shows all of the I/O signals as well as the direction of the signal—input, output, or bidirectional. Each chapter of this manual discusses one of the modules depicted in this block diagram.

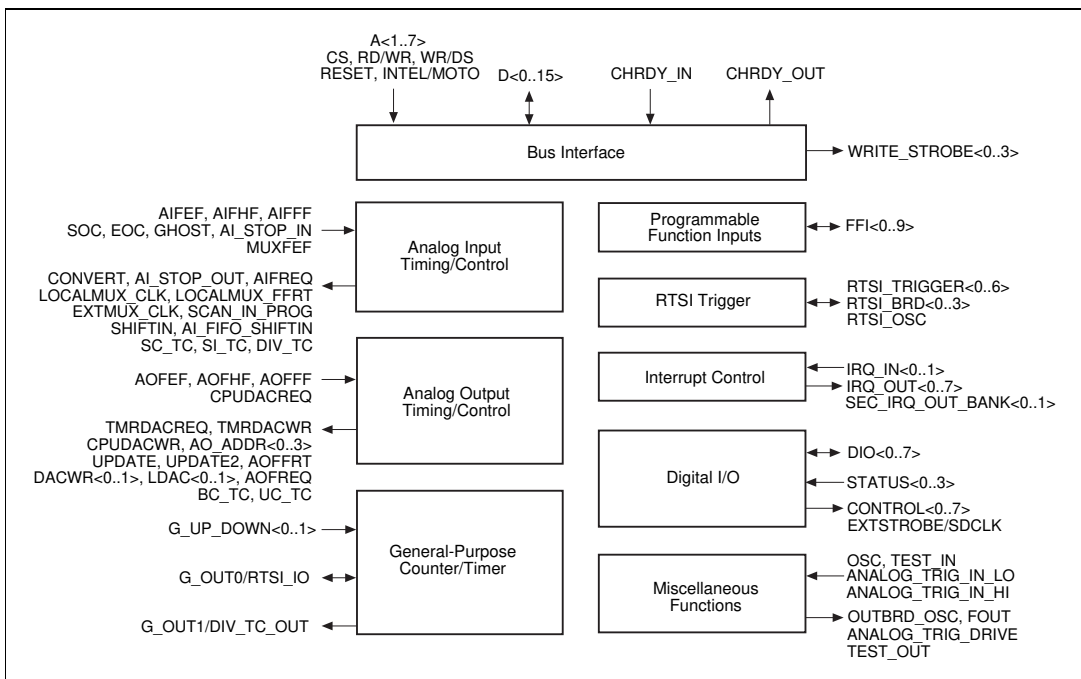

Figure 1-3. DAQ-STC Block Diagram

Analog Input Timing/Control

2.1 Overview

This chapter describes the analog input timing/control module (AITM), which generates timing for the ADC and controls signals for the associated circuitry. The AITM contains a 24-bit scan interval counter (SI), a 24-bit scan counter (SC), a 16-bit sample interval counter (SI2), and a 16-bit divide down counter (DIV).

There are eight timing and control signals associated with the analog input. These are the scan interval clock (SI source), sample interval clock (SI2 source), ADC conversion strobe (CONVERT), trigger (START1), second trigger (START2), start scan (START), stop scan (STOP), and external gate. The AITM contains independent multiplexers and conditioning circuits to derive these timing/control signals from any of 10 programmable function input (PFI) signals (PFI<0..9>), seven RTSI trigger signals (RTSI_TRIGGER<0..6>), or other internal signals.

This chapter presents a list of the AITM features, followed by a simplified model that introduces a few AITM-related signals, an overview of each of the AITM modes, a list of the external pins used by the AITM module, programming information for users who need to program the hardware at a low level, a complete list of the AITM timing diagrams, and a detailed description of the internal workings of the AITM. The final section is intended for advanced users. Read section 1.1.1, *Analog Input Application*, for more information about devices with which the AITM can work.

2.1.1 Programming the AITM

To program the AITM of the DAQ-STC, read the following:

- Section 1.1.1, *Analog Input Application*
- Sections 2.2, *Features*, through 2.6, *Programming Information*

As you read section 2.6, *Programming Information*, you will need to refer to section 2.7, *Timing Diagrams*. You will also need to consult the register-level programmer manual for the hardware containing the DAQ-STC. If you need additional help programming the AITM, read section 2.8, *Detailed Description*.

2.2 Features

The AITM has the following features:

- Scan interval timing
 - 24-bit scan interval down counter
 - Maximum frequency of 20 MHz yields 50 ns resolution with a maximum interval of 0.83 s
 - Divide-by-two timebase yields 100 ns resolution with a maximum interval of 1.67 s
 - Divide-by-200 timebase yields 10 μ s resolution with a maximum interval of 167 s
- Sample interval counter
 - 16-bit sample interval down counter
 - Maximum sample rate of 10 MS/s
 - Maximum interval of 3.3 ms between channels with 50 ns resolution
- External timing for the following signals
 - START
 - START1
 - START2
 - CONVERT
 - SI source, with special considerations for the SI2 source
 - STOP
 - External gate
- Bidirectional external timing pins
 - Input timing and control signals from PFI<0..9> and RTSI_TRIGGER<0..6>
 - Output the most important internally generated timing and control signals to the board
- Programmable polarities for clock sources, trigger inputs, and the most important timing outputs
- Ability to change the scan rate during an acquisition, in combination with the GPCT module or directly in software
- Scan count
 - 24-bit scan down counter
 - Trigger up to 2^{24} scans or generate scans continuously

- Trigger modes
 - Hardware and software triggering
 - Support for versatile analog triggering
- Delayed trigger
 - Interval counters have alternate first period capability for retriggerable delay from trigger
 - Minimum delay of one SI source clock
 - Maximum delay of 2^{24} SI source clocks
- Pretrigger
 - Count pretrigger scans and ignore START2 triggers until the pretrigger count has been satisfied
 - Synchronize multiple DAQ-STCs in the pretrigger mode
- Gating
 - Hardware and software gating
- Seamless interface to the configuration FIFO and the data FIFO
- Error detection
 - Overrun and overflow error-detection flags for internal or external timing
 - Error detection for excessive interrupt latency during staged analog input
- Bus interface support
 - Interrupts based on triggers, error conditions, and FIFO flags
 - FIFO-flag-based request signal to simplify DMA request logic
- Seamless interface to external analog input accessories
 - Multiplexer
 - 16-bit counter can generate internal multiplexer clock by dividing down the external multiplexer clock
 - Provides a clock for the external multiplexer
 - Simultaneous sample and hold
 - Generates the track-and hold-signal

2.3 Simplified Model

The AITM contains the hardware necessary to generate timing and control signals for the ADC and the associated circuitry on a National Instruments DAQ board, such as an MIO board. Figure 2-1 shows the timing and control signals used in a typical analog input operation.

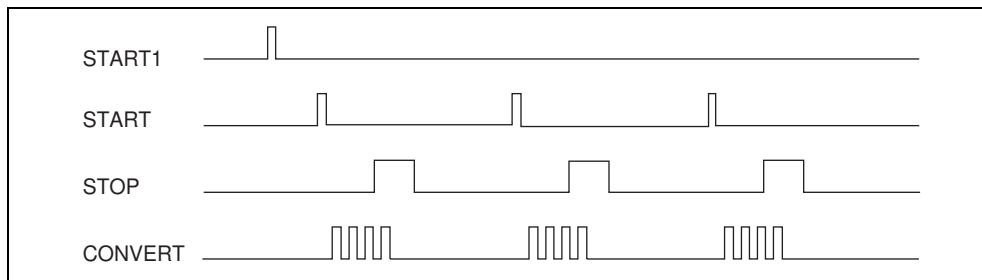

Figure 2-1. Typical Analog Input Waveform

The primary analog input timing signal is the CONVERT pulse, which instructs the ADC to begin a conversion on the selected analog input channel. CONVERT pulses are organized into groups called scans. In each scan, the CONVERT signal pulses once for each input channel. The purpose of the scan grouping is to sample multiple input channels nearly simultaneously. Each scan begins with a START pulse and ends with a STOP pulse. The START1 trigger begins the acquisition sequence. Figure 2-1 above depicts an acquisition consisting of three scans, with each scan sampling four input channels.

Figure 2-2 shows a simplified model of the AITM module.

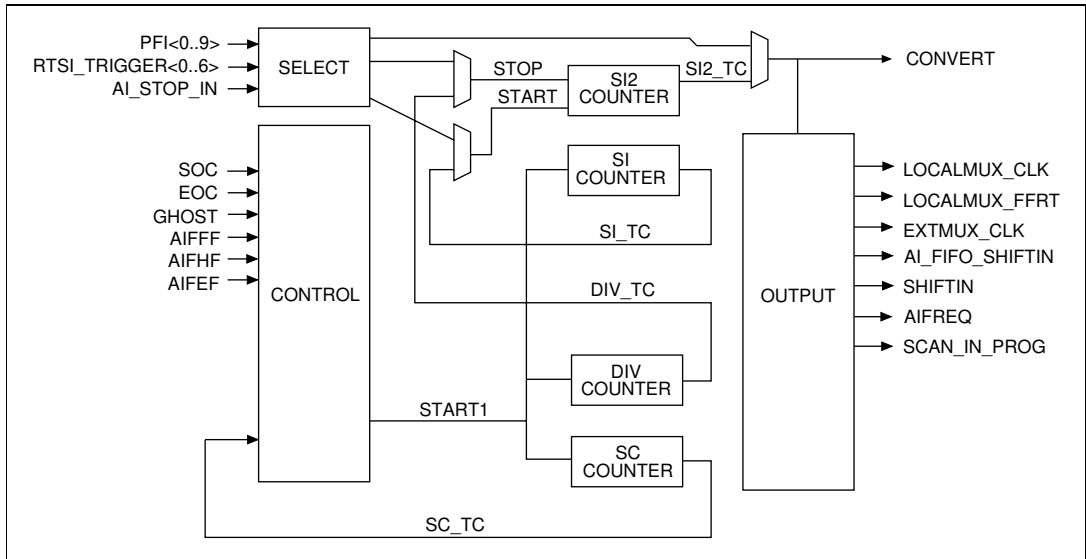

Figure 2-2. AITM Simplified Model

One of the primary features of the AITM is that a wide variety of signals can be selected as timing and control sources. The simplified model depicts this as a select circuit, which chooses between the 10 PFI signals PFI<0..9>, the seven RTSI signals RTSI_TRIGGER<0..6>, and the dedicated STOP input signal AI_STOP_IN. Many of the signals required for the ADC can come from external sources routed through the selector. The DAQ-STC can also generate the timing sources internally.

The simplified model in Figure 2-2 shows that the source for the CONVERT pulse may come from the SI2 counter (internal CONVERT source) or the select circuit (external CONVERT source). SOC (start of conversion) and EOC (end of conversion) are status signals generated by the ADC. SOC indicates that a conversion has begun and EOC indicates that a conversion is complete.

Using CONVERT as a reference, the output circuit generates several ancillary signals used on the board. The LOCALMUX_CLK (configuration FIFO advance) signal, which pulses after an integral number of CONVERTs, advances the configuration FIFO to the next input channel. The LOCALMUX_FFRT (configuration FIFO retransmit) signal, which pulses when the configuration FIFO empties, refills the configuration FIFO. The EXTMUX_CLK (external multiplexer clock) signal, which pulses on every CONVERT, advances the channel multiplexer. The SHIFTIN signals (AI_FIFO_SHIFTIN and SHIFTIN), which pulse after the ADC has completed a conversion, move the data into the analog input data FIFO. The AIFREQ (AI data FIFO request) signal generates a DMA request based on the analog input

FIFO flags AIFEF (AI data FIFO empty flag), AIFHF (AI data FIFO half-full flag), and AIFFF (AI data FIFO full flag). Refer to section 2.5, *Pin Locator Interface*, for a complete description of these signals.

The configuration FIFO may also supply the GHOST signal, which is updated on every CONVERT. When the GHOST input is active, the AI_FIFO_SHIFTIN pulse is suppressed following the conversion, so that the ADC data is not shifted into the AI data FIFO. This feature allows the DAQ-STC to support multirate sampling where channels are sampled at different input rates.

As shown in Figure 2-2, the START pulse may come from the SI counter (internal START source) or the PFI selector (external START source). Similarly, the STOP pulse may come from the DIV counter (internal STOP source) or the PFI selector (external STOP source). The SCAN_IN_PROG output indicates that a scan is in progress by asserting on START and deasserting on STOP.

The SC counter is available to count the number of scans that have occurred. This is useful for generating a specific number of scans in an acquisition. The START1 trigger signal begins the acquisition sequence and may come from one of several sources—PFI, RTSI, software, or general-purpose counter 0.

2.4 Analog Input Functions

The AITM is a highly flexible circuit that can accommodate a variety of timing scenarios. The most useful of these is the interval scanning mode. For this reason, the functional description will present interval scanning as the primary analog input mode.

For the purpose of discussion, the analog input functions can be divided into three groups—low-level timing and control, scan-level timing and control, and acquisition-level timing and control. Low-level timing and control refers to the timing signals related to and derived from CONVERT. Scan-level timing and control refers to the timing signals necessary to organize the CONVERT pulses into scans. Acquisition-level timing and control refers to the timing signals that govern the generation of scan sequences.

2.4.1 Low-Level Timing and Control

This section discusses CONVERT and the signals derived from CONVERT.

The CONVERT signal is the primary timing signal for analog input. Three board-level subsystems are controlled by CONVERT and the signals derived from CONVERT—the ADC, the data FIFO, and the configuration FIFO and external multiplexer. CONVERT timing is affected by your selection of internal or external CONVERT mode.

2.4.1.1 ADC Control

The basic function of the ADC control signals is to time ADC conversions and load the resulting digital data into a latch. The primary output signals are CONVERT and SHIFTIN, and the input signals are SOC and EOC. Figure 2-3 shows these signals in a basic data acquisition sequence.

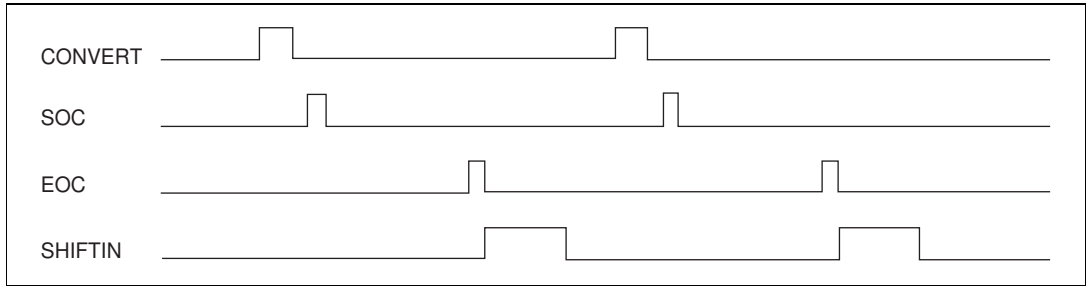

Figure 2-3. ADC Control

The SOC input informs the DAQ-STC when a conversion starts. Similarly, the EOC input notifies the DAQ-STC when a conversion completes. The assertion of EOC leads to the assertion of SHIFTIN, which loads the acquired data into its destination. An overrun condition occurs when the conversion rate is too high for the A/D subsystem to maintain. If a second CONVERT signal occurs before the current conversion is complete, the DAQ-STC flags an overrun error and generates an interrupt if programmed to do so.

2.4.1.2 Data FIFO Control

Many DAQ products include data FIFOs to prevent loss of data at high speeds and to increase bus bandwidth. The data FIFO control signals support such a FIFO. The SHIFTIN signal loads the result of each conversion into the data FIFO. Three status flags indicate the amount of data stored in the FIFO and are monitored by the DAQ-STC. The three status flags are AIFFF, AIFHF, and AIFEF. When the FIFO flags indicate that the FIFO level has exceeded a programmed threshold, the DAQ-STC notifies the host computer using either an interrupt request, if the CPU performs data transfers, or the DMA request signal AIFREQ, if the DMA controller performs data transfers. The host computer then transfers the input data stored in the data FIFO to main memory.

2.4.1.3 Configuration FIFO and External Multiplexer Control

Typical DAQ products provide a means of setting channel, gain, polarity, and other configuration information for the A/D subsystem. Recent products offer the ability to change this information on a per conversion basis. The DAQ-STC fully supports a FIFO-based configuration memory that can update on every CONVERT pulse. Typically, the configuration FIFO contains one data word for each input channel included in the scan. At the

end of the scan, the FIFO read pointer is reset, effectively reloading the FIFO with the configuration list. The LOCALMUX_CLK signal, which asserts at the same time as CONVERT, advances the configuration FIFO. At the leading edge of the final LOCALMUX_CLK, the configuration FIFO becomes empty, causing MUXFEF to assert. When MUXFEF asserts, LOCALMUX_FFRT pulses on the trailing edge of LOCALMUX_CLK, causing the configuration FIFO to reload the entire configuration list. Figure 2-4 shows the operation of these signals during two scans, where each scan contains four channels.

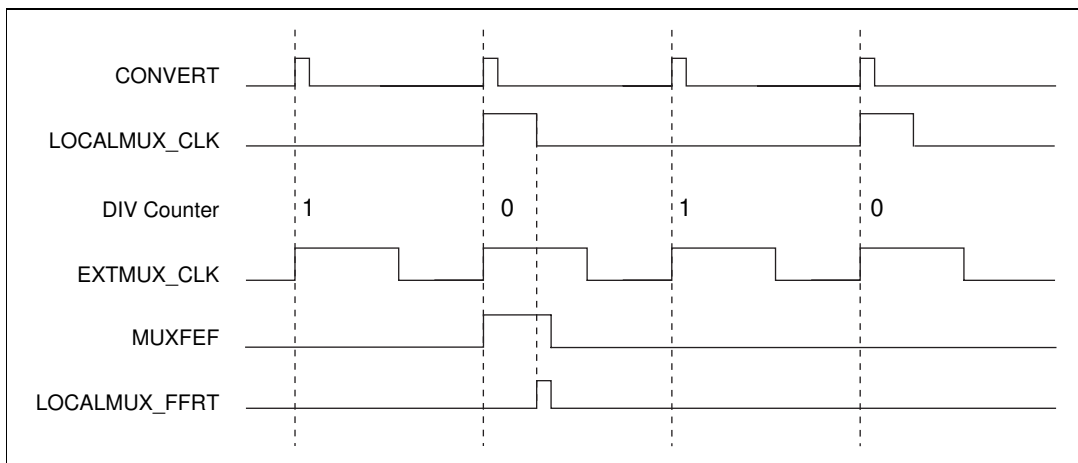

Figure 2-4. Configuration FIFO Control

In addition to supporting the configuration FIFO, the DAQ-STC also supports an external multiplexer. Typically, analog input boards are limited to eight or 16 input channels. An external multiplexer overcomes this limitation by time division, multiplexing several analog signals onto each input channel. Each memory location in the configuration FIFO corresponds to one input channel. With an external multiplexer, the configuration FIFO does not advance until all the external channels have been sampled for a given input channel. The EXTMUX_CLK signal is available to advance the external multiplexer.

To use the DAQ-STC with an external multiplexer, you load the DIV counter with the number of external channels corresponding to each input channel. The EXTMUX_CLK signal pulses on every CONVERT, but the LOCALMUX_CLK signal pulses only when the DIV counter reaches state 0. Figure 2-5 shows the operation of these signals during a scan where four external channels are multiplexed onto each of two input channels.

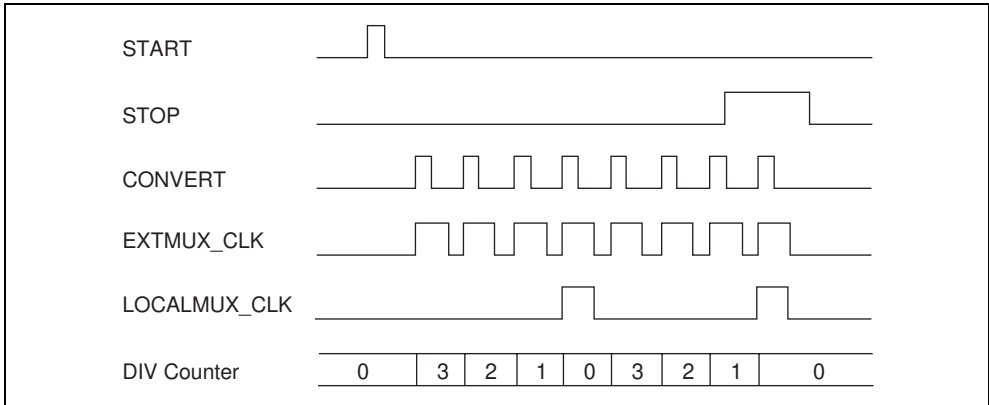

Figure 2-5. External Multiplexer Control

2.4.1.4 CONVERT Timing

As discussed in section 2.3, *Simplified Model*, sequences of CONVERT pulses are organized into scans, which begin on START and terminate on STOP. The DAQ-STC can generate the timing for the individual CONVERT pulses using the SI2 counter (internal CONVERT), or the timing for CONVERT can come from an external source (external CONVERT). With an external CONVERT, the SI2 counter is unused.

Internal CONVERT

In the internal CONVERT mode, the hardware generates the CONVERT pulses on SI2_TC (SI2 counter TC). The START trigger causes the SI2 counter to begin counting and the STOP trigger causes the SI2 counter to stop counting. Refer to section 2.4.2, *Scan-Level Timing and Control*, for more information on the START trigger. The STOP trigger, which asserts after the appropriate number of conversions, usually comes from the configuration FIFO. A second option for generating the STOP trigger, an internal STOP, is to configure the DIV counter to count the number of conversions, load the DIV counter with the number of conversions per scan, then use the DIV counter TC as the STOP signal. However, you cannot use an internal STOP and an external multiplexer at the same time because they both use the DIV counter.

The SI2 counter has dual load registers that allow two timing parameters at the CONVERT timing level. The first parameter, A, gives the delay from START to the first CONVERT. The second parameter, B, gives the delay between CONVERT pulses. The SI2 reload mode setting allows the SI2 counter to alternate load registers on every STOP, thus providing the dual timing feature.

Figure 2-6 shows two scans with four internally timed CONVERT pulses each to indicate the available timing parameters. The SCAN_IN_PROG output asserts on START and deasserts at the completion of the scan.

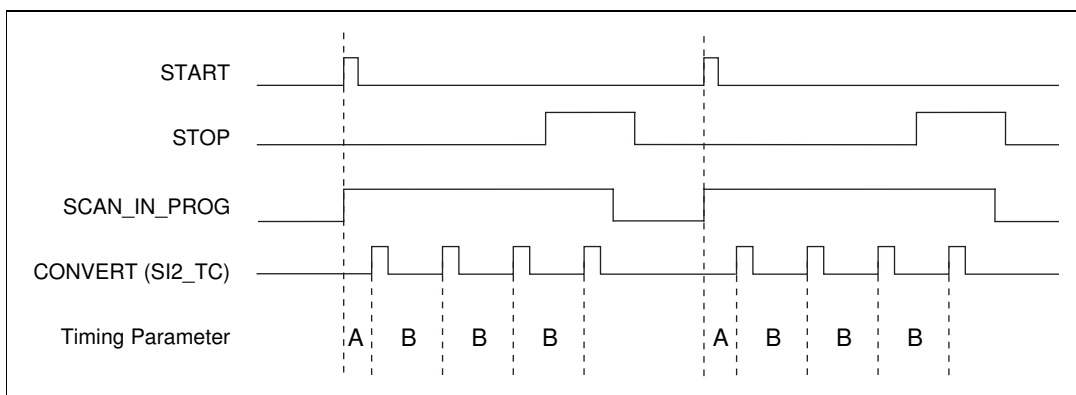

Figure 2-6. Internal CONVERT Timing

External CONVERT

In the external CONVERT mode, the externally generated CONVERT pulses enter the DAQ-STC through one of the PFI<0..9> or RTSI_TRIGGER<0..6> inputs. In order to preserve the concept of interval scanning with an external CONVERT, the STST_GATE (Start/Stop Gate) is available. The START trigger enables the STST_GATE and the STOP trigger disables the STST_GATE.

External CONVERT pulses that occur when the STST_GATE is enabled pass through the DAQ-STC. External CONVERT pulses that occur when the STST_GATE is disabled are blocked.

Timing for the external CONVERT can be arbitrarily complex depending on the behavior of the signal you select as the external CONVERT source. Typically, though, you will select a periodic signal, in which case the only timing parameter available is the delay between CONVERT pulses. The delay from START to the first CONVERT depends on the relationship between the START trigger and the external CONVERT and can vary.

Figure 2-7 shows two scans with four externally timed CONVERT pulses each and indicates how the delay from START to the first CONVERT can vary. The SCAN_IN_PROG output asserts on the recognition of START and deasserts on STOP.

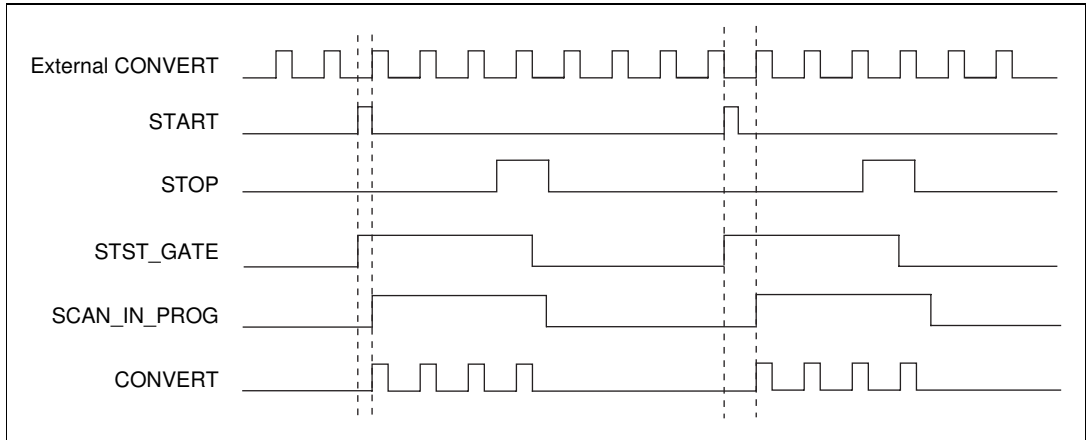

Figure 2-7. External CONVERT Timing

Although successive CONVERT pulses in Figure 2-7 are equidistant, they could follow any other timing.

2.4.2 Scan-Level Timing and Control

As discussed in section 2.3, *Simplified Model*, sequences of CONVERT pulses are organized into scans. Each scan begins with a START pulse. The START pulse may come from either the SI counter (internal START mode) or the PFI selector (external START mode).

2.4.2.1 Internal START Mode

In the internal START mode, the SI_TC (SI counter TC) signal becomes the START pulse. The START1 trigger causes the SI counter to generate the START pulses which continue until the acquisition sequence is complete. Refer to section 2.4.3, *Acquisition-Level Timing and Control*, for more information on the START1 trigger.

The SI counter has dual-load registers that allow for two timing parameters at the START timing level. The first parameter (A) gives the delay from START1 to the first START. The second parameter (B) gives the delay between START pulses.

Figure 2-8 shows three scans of four CONVERT pulses each to indicate the timing parameters that are available.

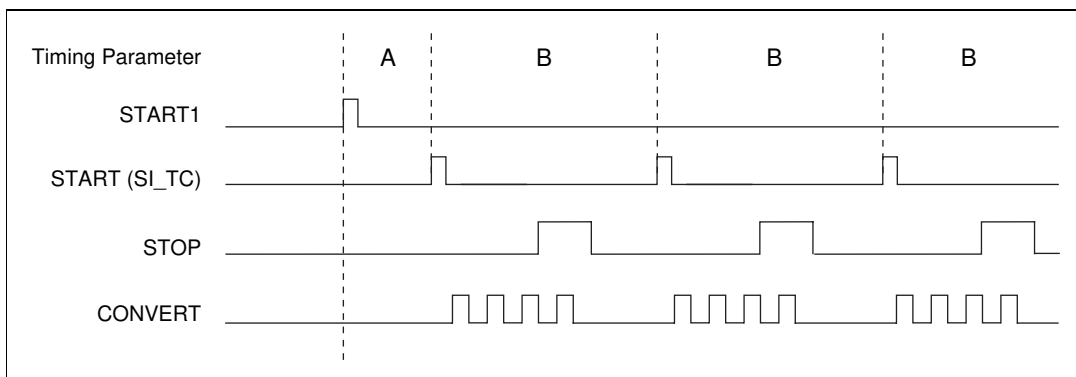

Figure 2-8. Internal START

2.4.2.2 External START Mode

In the external START mode, the externally generated START pulses enter the DAQ-STC through one of the PFI<0..9> or RTSI_TRIGGER<0..6> inputs or from general-purpose counter 0. When the counters are armed and a START1 pulse is received, the DAQ-STC is ready to recognize external START pulses. Each external START initiates a scan, causing the DAQ-STC to generate CONVERT pulses until a STOP is received. If the external START pulses occur at a rate higher than the DAQ-STC can maintain, the extra external START pulses are ignored.

The timing for the external START can be arbitrarily complex depending on the behavior of the signal you select as the external START source. Typically, though, you will select a periodic signal, in which case the only timing parameter available is the delay between START pulses. The delay from START1 to the first START depends on the relationship between the START1 trigger and the external START and can vary.

Figure 2-9 shows three scans of four CONVERT pulses each, where the scans are initiated by an external START.

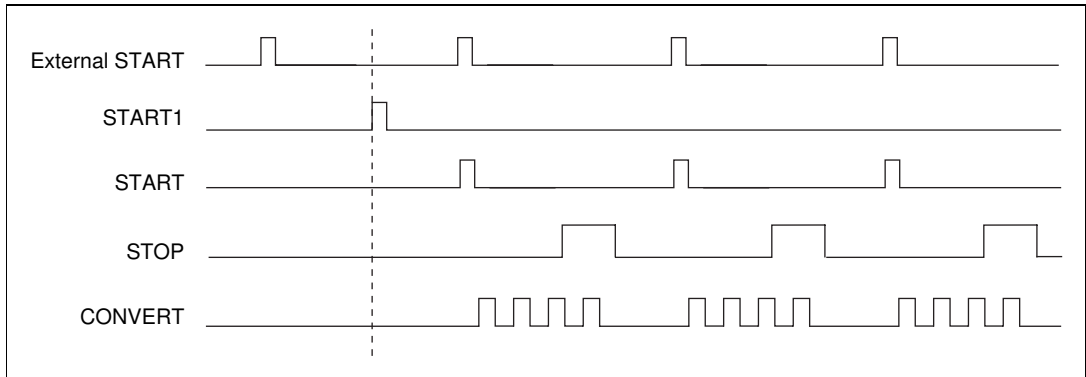

Figure 2-9. External START

In the external START mode, the SI special trigger delay feature of the SI counter allows an extra timing parameter in the scan timing. This feature allows you to enforce a minimum delay from the START1 trigger to the first START. When the SI special trigger delay is enabled, the SI counter blocks external START pulses for a fixed time period after the START1 trigger. Software can program the SI counter to count edges on the internal IN_TIMEBASE signal for an absolute time delay, or it can program the SI counter to count edges on the external START signal for a delay in terms of the number of START pulses blocked.

Figure 2-10 depicts the SI special trigger delay feature where the SI counter counts edges on the internal IN_TIMEBASE signal. The START1 pulse causes the SI counter to begin counting. External START pulses are not recognized until the SI_TC. This feature gives the user greater control over the external START timing.

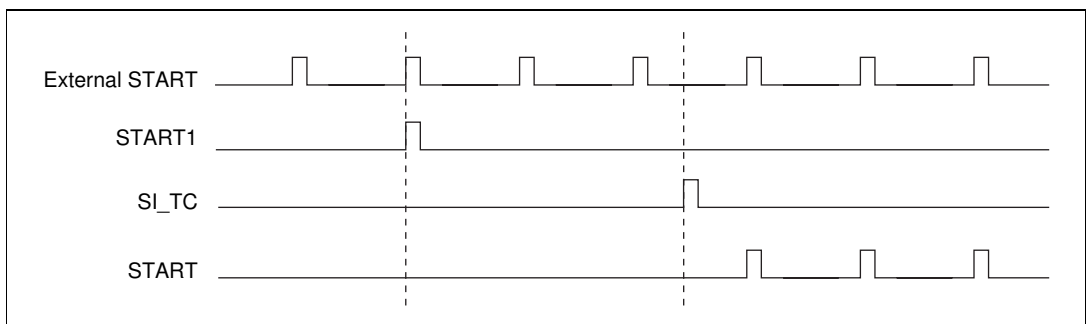

Figure 2-10. SI Special Trigger Delay

2.4.3 Acquisition-Level Timing and Control

The SC counter is available to control the acquisition-level timing. Two trigger signals are available for acquisition-level timing—the START1 trigger and the START2 trigger. The DAQ-STC has three acquisition-level timing modes—posttrigger mode, pretrigger mode, and continuous acquisition mode. This section discusses the operation of the START1 and START2 triggers in the context of these three timing modes.

2.4.3.1 Posttrigger Acquisition Mode

In the posttrigger acquisition mode, only one parameter is required—the number of scans to complete. The START1 pulse initiates the scan sequence. The SC counter counts the number of scans and terminates the acquisition upon completion of the programmed number of scans. Posttrigger acquisitions can be retriggerable or nonretriggerable. In the retriggerable mode, additional START1 pulses that occur after SC_TC initiate additional acquisition sequences. In the nonretriggerable mode, only one acquisition sequence is allowed. Externally generated START1 and START2 triggers enter the DAQ-STC through one of PFI<0..9> or RTSI_TRIGGER<0..6>.

Figure 2-11 shows a single-posttrigger acquisition sequence consisting of three scans.

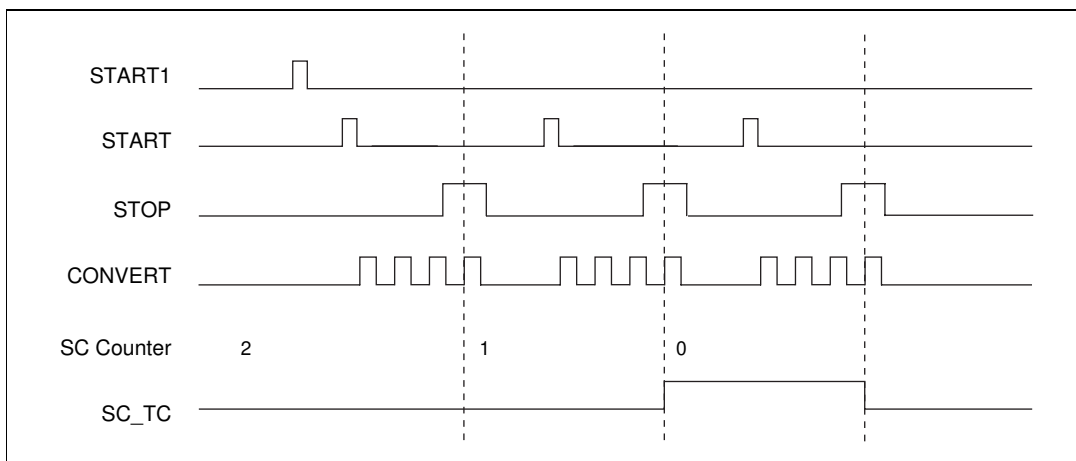

Figure 2-11. Posttrigger Acquisition Mode

2.4.3.2 Pretrigger Acquisition Mode

In the pretrigger acquisition mode, two parameters are required. The first parameter gives the pretrigger count requirement; that is, the number of scans that must occur before START2 can be recognized. The second parameter gives the posttrigger count requirement; that is, the number of scans that will occur after START2 is recognized.

The START1 pulse initiates the scan sequence. After the pretrigger count requirement has been satisfied, the DAQ-STC looks for the START2 trigger while continuing to generate scans. When the START2 trigger has been received, the hardware generates a specific number of additional scans according to the posttrigger count requirement. Pretrigger acquisitions can be retriggerable or nonretriggerable. In the retriggerable mode, additional START1 pulses initiate additional acquisition sequences. In the nonretriggerable mode, only one acquisition sequence is allowed. Alternatively, START1 can come from general-purpose counter 0.

Figure 2-12 shows a single pretrigger acquisition sequence with a pretrigger count requirement of four scans and a posttrigger scan requirement of three scans. The total number of scans acquired before START2 occurs is six because the START2 trigger occurs after the sixth scan but before the start of the second scan. The vertical lines indicate where the SC counter transitions occur.

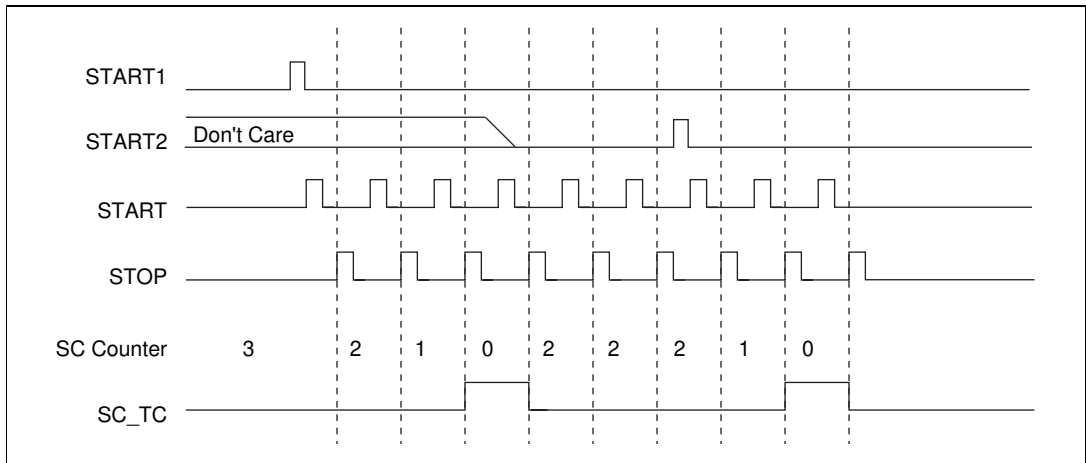

Figure 2-12. Pretrigger Acquisition Mode

2.4.3.3 Continuous Acquisition Mode

In the continuous acquisition mode, the START1 trigger initiates the scan sequence. The hardware continues to generate scans until the software issues an AI_End_On_End_Of_Scan command, an AI_End_On_SC_TC command, or a software reset command. The AI_End_On_End_Of_Scan command terminates the scan sequence at the end of the next scan. The AI_End_On_SC_TC command terminates the scan sequence at the next SC_TC (SC counter TC). The software reset command terminates the scan sequence immediately.

2.4.3.4 Staged Acquisition

Staged acquisition refers to the software action required to implement more than one posttrigger acquisition sequence, each having unique timing parameters. This section discusses how the software might handle staged acquisition.

In a programming sequence that occurs prior to the START1 trigger, software loads the parameter values for the first two acquisition sequences. Software also configures the counters to switch load registers after each acquisition sequence has completed, providing for the switch from one sequence to the next. While the second sequence is in progress, software loads the parameters for the third sequence into the unused load registers. Switching between load registers occurs at the end of each sequence, that is, at SC_TC. This arrangement allows the software a maximum latency of up to the duration of the sequence in progress to finish writing the set of values for the next sequence into the alternate load register set.

Error detection is provided in case the next parameter set is not written in the allotted time. The error-detection circuit is armed on each SC_TC. If a software clear does not occur before the next SC_TC, the error-detection circuit latches an SC_TC error condition.

2.4.3.5 Master/Slave Trigger

Use master/slave triggers whenever you need DAQ devices with multiple DAQ-STC ASICs to acquire data in a synchronized manner; that is, when multiple ASICs share the same START1 and START2 triggers. With master/slave triggering, one DAQ-STC is designated to be the master trigger ASIC, sourcing the START1 and START2 triggers to the other ASICs through the PFI<0..9> or RTSI_TRIGGER<0..6> interface. This arrangement provides better synchronization than if all DAQ-STC ASICs receive the same START1 and START2 triggers independently, because different ASICs may synchronize differently.

In master/slave triggering, all DAQ-STC AITMs are timed from a common source. The master ASIC delays recognition of the START1 and START2 triggers by one source period to allow the slave ASICs adequate time to receive the triggers. On the following source edge, all of the ASICs simultaneously begin the programmed acquisition sequence. Master/slave triggering can be used with any of the three acquisition modes—pretrigger, posttrigger, or continuous acquisition mode.

2.4.4 Gating

The DAQ-STC also supports gating, an additional external control layer. Both an external source coming through the PFI<0..9> or RTSI_TRIGGER<0..6> interface and software can supply the optional control signal. Gating provides a mechanism to pause the data acquisition operation. When the START signal is internally generated (by the SI counter), gating is available in two modes—free-run and halt. When the START signal is externally generated, only free-run gating is available. In all modes, the conversion signal CONVERT is gated on a scan basis; that is, entire scans are gated on or off.

2.4.4.1 Free-Run Gating Mode

In the free-run gating mode, the scan timing continues without interruption while the outputs are gated off. For the internal START case, the SI counter continues to count regardless of the gating signal. If the external gate is asynchronous to the SI source (internal START mode) or to the external START, the delay between active gate level and first conversion of a scan varies and can be as long as one scan interval.

Figure 2-13 shows two scans and the location of the third scan had it not been gated off.

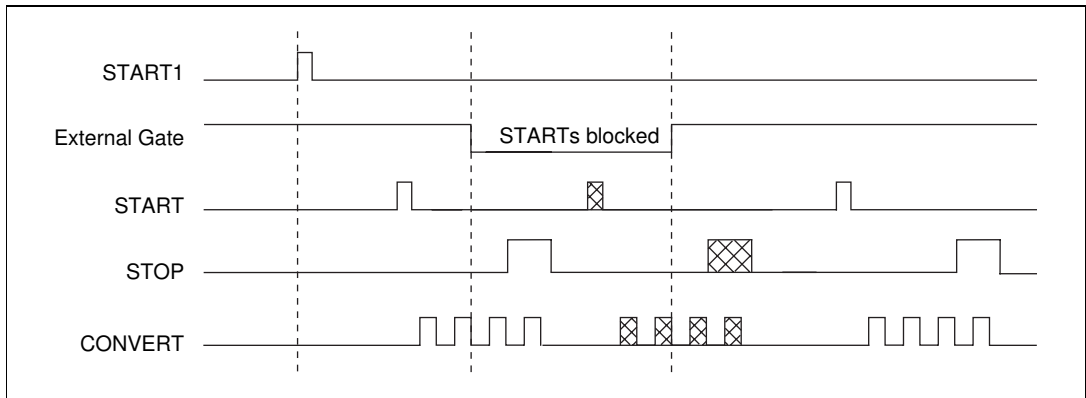

Figure 2-13. Free-Run Gating Mode

2.4.4.2 Halt-Gating Mode

Halt-gating mode is available only when the START signal is generated internally. In the halt-gating mode, the delay from the assertion of the external gate to the next CONVERT is minimized. The SI counter counts down normally until it reaches a count value of one. At this point, the behavior of the SI counter depends upon the external gate. If the external gate is deasserted, the SI counter pauses so that no START pulses are generated. When the external gate asserts, the START occurs immediately (with jitter of up to one SI source clock period). The external gate works as a pseudotrigger for a scan in this mode.

Figure 2-14 shows three scans where the second scan has been delayed by the action of the external gate. START is asserted immediately upon the assertion of the external gate. START (SI_TC) is asserted immediately upon the assertion of the external gate. STOP is asserted immediately upon the assertion of the external gate. CONVERT is asserted immediately upon the assertion of the external gate.

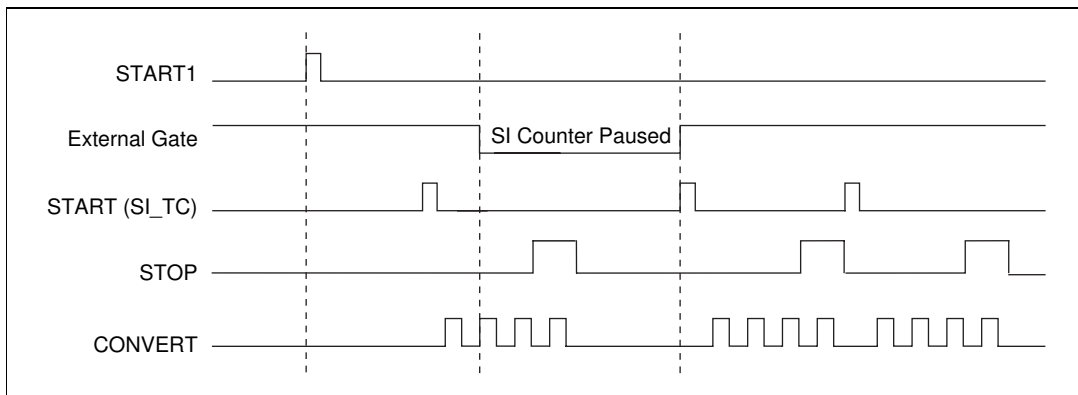

Figure 2-14. Halt-Gating Mode

2.4.5 Single-Wire Mode

In the single-wire mode, one signal is used as both an external START and an external CONVERT. Interval-scan timing is still permitted, although the number of timing parameters is quite limited. Figure 2-15 shows an example of three scans of four CONVERT pulses each in single-wire mode.

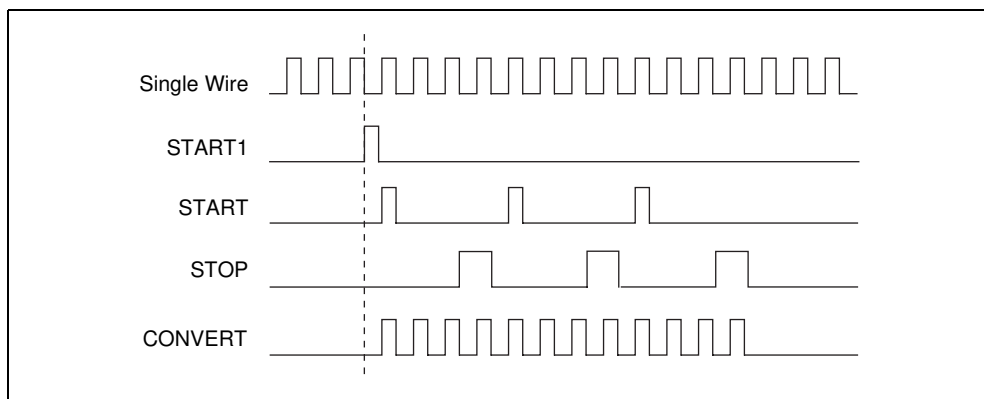

Figure 2-15. Single-Wire Mode

2.5 Pin Locator Interface

The I/O signals relevant to analog input are listed in Table 2-1. An asterisk following a pin name indicates that the default polarity for that pin is active low.

Pin Type Notation:

IU	Input, pull up (50 k Ω)
IU5	Input, pull up (5 k Ω)
O4TU	Output, 4 mA sink, 2.5 mA source tri-state, pull up (50 k Ω)
O9TU	Output, 9 mA sink, 5 mA source, tri-state, pull up (50 k Ω)

Table 2-1. Pin Interface

Pin Name	Type	Description
AIFEF*	IU	Data FIFO Empty Flag—This input generates the FIFO interrupt and the FIFO request signal (AIFREQ) based on the status of the FIFO. The input polarity is selectable, and the input state can be directly observed in one of the status registers. Source: AI data FIFO. Related bitfields: AI_FIFO_Flags_Polarity, AI_FIFO_Empty_St.
AIFFF*	IU	Data FIFO Full Flag—This input is used to generate the FIFO interrupt and the FIFO request signal (AIFREQ) based on the status of the FIFO. The input polarity is selectable, and the input state can be directly observed in one of the status registers. Source: AI data FIFO. Related bitfields: AI_FIFO_Flags_Polarity, AI_FIFO_Full_St.
AIFHF*	IU	Data FIFO Half-full Flag—This input generates the FIFO interrupt and the FIFO request signal (AIFREQ) based on the status of the FIFO. The input polarity is selectable, and the input state can be directly observed in one of the status registers. Source: AI data FIFO. Related bitfields: AI_FIFO_Flags_Polarity, AI_FIFO_Half_Full_St.
AI_FIFO_SHIFTIN*	O9TU	Data FIFO Write Clock—This output shifts the ADC data from the ADC into the data FIFO at the end of conversion. The AI_FIFO_SHIFTIN pulse is asserted on EOC and remains asserted based on the selected pulsewidth. The AI_FIFO_SHIFTIN pulse is inhibited for the conversions that occur when the GHOST signal is active. Output polarity is selectable. Destination: AI data FIFO. Options: Active Low, Active High. Related bitfields: AI_SHIFTIN_Polarity, AI_SHIFTIN_Pulse_Width.

Table 2-1. Pin Interface (Continued)

Pin Name	Type	Description
AIFREQ	O4TU	Data FIFO Request—This output is a FIFO request signal that indicates that the data FIFO contains data that requires service. The AIFREQ signal is generated directly from the data FIFO status flags (AIFEF, AIFHF, and AIFFF) and the internal SC_TC signal. Output polarity is selectable. Destination: DMA Controller or CPU. Options: Active Low, Active High. Related bitfields: AI_AIFREQ_Polarity, AI_FIFO_Mode.
AI_STOP_IN	IU5	Dedicated STOP Input—This input provides a optimized path for the end-of-scan signal (LAST_CH) from the configuration FIFO. Internally, the AI_STOP_IN signal is routed directly to the STOP selector. Source: Configuration FIFO. Related bitfields: AI_STOP_Select.
AI_STOP_OUT	O4TU	Dedicated STOP Output—This output reflects the state of the active high internal STOP signal. The hardware generates AI_STOP_OUT and the internal STOP signal by passing the output of the STOP selector through polarity selection, edge detection, and synchronization. Output polarity is selectable. Related bitfields: AI_STOP_Select, AI_STOP_Polarity, AI_STOP_Edge, AI_STOP_Sync, AI_STOP_St.
CONVERT*	O9TU	ADC Conversion Strobe—This output instructs the ADC to perform a conversion. The hardware generates CONVERT by passing the internal sample clock (SCLK) signal through pulsewidth and polarity selection circuitry. Output polarity is selectable. Destination: ADC. Options: Active Low, Active High, Ground, High Z. Related bitfields: AI_CONVERT_Output_Select, AI_CONVERT_Pulse, AI_CONVERT_Original_Pulse, AI_CONVERT_Pulse_Timebase, AI_CONVERT_Pulse_Width.
DIV_TC	O4TU	DIV Counter TC Signal—Output polarity is active high. Related bitfields: Misc_Counter_TC_S_Output_Enable.

Table 2-1. Pin Interface (Continued)

Pin Name	Type	Description
EOC	IU	End of Conversion—This input indicates that a conversion is complete. Internally, the EOC signal causes the SHIFTIN pulse to be generated and causes the overrun error-detection circuitry to end the overrun-detection interval (in overrun mode 0). The input polarity is selectable, and the input state can be directly observed in one of the status registers. Source: ADC. Related bitfields: AI_EOC_Polarity, AI_EOC_St, AI_Overrun_Mode.
EXTMUX_CLK	O9TU	External Multiplexer Clock—This output pulses after each CONVERT to clock an external multiplexer such as the AMUX-64, causing the multiplexer to switch to the next entry in the external scan list. Two output modes are available for the EXTMUX_CLK output. In the first mode, EXTMUX_CLK trails the LOCALMUX_CLK pulse by 0.5 - 1.5 AI_OUT_TIMEBASE periods and has a pulsewidth of 4.5 AI_OUT_TIMEBASE periods. In the second mode, EXTMUX_CLK and LOCALMUX_CLK are asserted at the same time (when LOCALMUX_CLK is asserted), and their pulsewidths are equal. Output polarity is selectable. Destination: External Multiplexer. Options: Active Low, Active High, Ground, High Z. Related bitfields: AI_EXTMUX_CLK_Output_Select, AI_EXTMUX_CLK_Pulse, AI_EXTMUX_CLK_Pulse_Width.
GHOST	IU	Ghost Input—This active high input masks the AI_FIFO_SHIFTIN pulses associated with specific channels to allow multirate scanning. The GHOST signal is produced by the configuration FIFO containing the scan list. Source: Configuration FIFO.

Table 2-1. Pin Interface (Continued)

Pin Name	Type	Description
LOCALMUX_CLK*	O4TU	Configuration FIFO Advance Clock—This output clocks the local configuration FIFO containing the scan list, thereby updating the channel, gain, and channel configuration selections. The LOCALMUX_CLK pulse is asserted on CONVERT and remains asserted based on the selected pulsewidth, with the added condition that SOC must arrive before the signal is deasserted. When an external multiplexer is present, the LOCALMUX_CLK signal can be configured to pulse only after every <i>n</i> conversions, where <i>n</i> is determined by the value in the 16 bit DIV counter. This is useful when an external multiplexer is used to switch more than one active channel into a channel in the scan list. Output polarity is selectable. Destination: Configuration FIFO. Options: Active Low, Active High, Ground, High Z. Related bitfields: AI_LOCALMUX_CLK_Output_Select, AI_LOCALMUX_CLK_Pulse, AI_LOCALMUX_CLK_Pulse_Width,
LOCALMUX_FFRT*	O9TU	Configuration FIFO Retransmit—This output indicates that the configuration FIFO should repeat the scan list. When MUXFEF is active, the LOCALMUX_FFRT signal is asserted on the trailing edge of LOCALMUX_CLK and remains asserted based on the selected pulsewidth. Output polarity is active low. Destination: Configuration FIFO. Related bitfields: AI_LOCALMUX_CLK_Pulse_Width.
MUXFEF	IU	Configuration FIFO Empty Flag—This input indicates that the configuration FIFO is empty. The MUXFEF signal is used to generate the configuration FIFO retransmit signal (LOCALMUX_FFRT). The input polarity is selectable. Source: Configuration FIFO. Related bitfields: AI_FIFO_Flags_Polarity.

Table 2-1. Pin Interface (Continued)

Pin Name	Type	Description
SCAN_IN_PROG	O4TU	Scan in Progress—This output indicates that a scan is in progress. It is useful for generating track/hold signals for on board track and hold systems in a simultaneous sampling environment. In the internal CONVERT mode, SCAN_IN_PROG is asserted when START is recognized. In the external CONVERT mode, SCAN_IN_PROG is asserted on the first CONVERT of each scan. The signal remains asserted until SOC occurs while the internal STOP is active. Output polarity is selectable. Destination: Sample and hold circuit. Options: Active Low, Active High, Ground, High Z. Related bitfields: AI_SCAN_IN_PROG_Output_Select, AI_SCAN_IN_PROG_Pulse.
SC_TC	O9TU	SC Counter TC—This signal indicates the end of a data acquisition operation. Output polarity is active high. Related bitfields: Misc_Counter_TCs_Output_Enable.
SHIFTIN*	O9TU	Data Shift Pulse—This output sends ADC data over the serial link. The serial link transfers data serially across the RTSI bus but is not currently supported. The signal is similar to AI_FIFO_SHIFTIN except that its generation is not inhibited by the GHOST signal. The SHIFTIN pulse is asserted on EOC and remains asserted based on the selected pulsewidth. Output polarity is active low. Destination: Serial Data Link. Related bitfields: AI_SHIFTIN_Pulse_Width.
SI_TC	O4TU	SI Counter TC Signal—Output polarity is active high. Related bitfields: Misc_Counter_TCs_Output_Enable.
SOC	IU	Start of Conversion—This input indicates that a conversion has begun. Internally, the SOC signal allows the trailing edge of LOCALMUX_CLK to occur, enables the overrun error-detection circuitry to start the overrun-detection interval, and terminates the SCAN_IN_PROG signal (when STOP is asserted). The input polarity is selectable, and the input state can be directly observed in one of the status registers. Source: ADC. Related bitfields: AI_SOC_Polarity, AI_SOC_St.

2.6 Programming Information

Programming the DAQ-STC involves writing to and reading from the registers on the chip. The programming instructions are language independent; that is, they instruct you to write a value to a given bitfield or register or to detect the state of a bitfield or a register without presenting the actual code.

This section presents the functions required to implement some common analog input applications, which are described in pseudocode that refers to the various bitfields. Bitfield descriptions relevant to the AITM modules are also included. The bitfield descriptions are intended to be used as a reference. See Appendix B, *Register Information*, for the DAQ-STC register map and to locate specific bitfield descriptions in this manual.

A bitfield is a bit in a register, a group of functionally related bits in one register, or a pair of registers that jointly perform a function. If a bitfield consists of several bits within one register, the locations of the bits must be contiguous. Pairs of 16-bit registers are needed for loading and saving the 24-bit counter contents. Each pair of registers is treated as a single bitfield in this document.

2.6.1 Register and Bitfield Programming Considerations

Several write-only registers on the DAQ-STC contain bitfields that control a number of functionally independent parts of the chip. To follow the instructions for assigning values to bitfields, you must set or clear bits without changing the current state of the remaining bits in the register. However, writing to these registers affects all register bits. You cannot read these registers to determine which bits have been set or cleared in the past; therefore, you should maintain a software copy of the write-only registers. You can then use this software copy to determine the status of write-only registers. Because some bitfields get cleared automatically, you should keep your software copies current. To change the state of a single bitfield without disturbing the remaining bits, perform the following steps:

1. Make a secondary copy of the software copy.
2. Clear the bitfield in the secondary copy.
3. Place the new bitfield value in the secondary copy.
4. Write the value of the secondary copy to the register.
5. If the bitfield is not cleared automatically, update the software copy by replacing it with secondary copy.

Bitfields that get cleared automatically are called strobe bits. To change the state of a bitfield that spans over two registers, you need to write to both registers.

2.6.2 Windowing Registers

All of the write-only and read-only registers on the DAQ-STC can be addressed in two modes—direct mode and windowed mode. A particular implementation on a board may use either or both of these modes.

Direct mode allows direct access to all of the DAQ-STC registers. The register addresses are calculated by adding the register offset to the base address assigned to the DAQ-STC on the particular board. The *Register Maps* section of Appendix B, *Register Information*, lists the register offsets.

Windowed mode allows a smaller address space requirement for the DAQ-STC at the expense of requiring more accesses to perform the same task. In this mode, all DAQ-STC register accesses use the `Window_Address_Register` and `Window_Data_Register`. Refer to the 7.6.1, *Windowed Mode Register Access Example* section of Chapter 7, *Digital I/O*, for more information on windowing mode and for an example program.



Caution *When using windowed-mode accesses from an interruptable process, your application may not function properly if an interrupt occurs between the time that the address is loaded into the `Window_Address_Register` and the time that an access is made from the `Window_Data_Register`. Make sure that the interrupt does not disturb the `Window_Address_Register` during this sensitive period; disable interrupts during windowed-mode accesses or write the interrupt routines so that they do not disturb the contents of the `Window_Address_Register`.*

2.6.3 Programming for an Analog Input Operation

This section contains detailed programming information for bit-level programming of the AITM for specialized applications. The programs are presented in a bottom-up fashion. This section lists functions that can be used to configure the AITM for various operations. The functions are then assembled into a complete program in section 2.6.3.16, *Analog Input Program*.

Most of the programming sequences presented here must be executed exactly as shown. *Bitfield assignments* are defined as pseudocode instructions of the form `<bitfield name> = <value>`. Pseudocode sequences enclosed in braces that contain only bitfield assignments can normally be executed in any order, or simultaneously, if possible. If the sequence must be executed in exact order, the character Σ marks the boundary between two groups of assignments that have to be executed sequentially. For example, in the following pseudocode, the first bitfield assignment must be performed first, the second and third assignments may then be executed in any order, but the fourth bitfield assignment must be executed after the second and third bitfield assignments. Other programming constructs, such as if-then, should be executed in the order shown.

```

{
    FOUT_Enable = 0;
    Σ
    FOUT_Timebase_Select = 0 (FOUT_IN_TIMEBASE1) or 1 (IN_TIMEBASE2);
    FOUT_Divider = 0 (for division factor 16) or 1-15 (for division factor 1-15);
    Σ
    FOUT_Enable = 1;
}

```

The directives *Begin critical section* and *End critical section* mark the beginning and end of critical sections in the ensuing pseudocode. All statements under these directives must be synchronized with the ISRs; in other words, while the code fragment under these directives is executing in the foreground, all interrupt-time-specific code must be prevented from executing in the background.

Under some single-tasking operating systems such as DOS, the directives *Begin critical section* and *End critical section* directly map to CLI and STI assembly-language instructions, respectively. However, other operating systems may require specific primitives to achieve this functionality.

2.6.3.1 Resetting

Assume the AITM was set up to perform an unknown operation. The object is to stop any activities in progress.

Function AI_Reset_All

```

{
    Begin critical section;
    AI_Reset = 1;
    Σ
    AI_Configuration_Start = 1;
    Σ
    AI_SC_TC_Interrupt_Enable = 0;
    AI_START1_Interrupt_Enable = 0;
    AI_START2_Interrupt_Enable = 0;
    AI_START_Interrupt_Enable = 0;
    AI_STOP_Interrupt_Enable = 0;
    AI_Error_Interrupt_Enable = 0;
    AI_FIFO_Interrupt_Enable = 0;
    Σ
    AI_SC_TC_Error_Confirm = 1;
    AI_SC_TC_Interrupt_Ack = 1;
    AI_START1_Interrupt_Ack = 1;
    AI_START2_Interrupt_Ack = 1;
    AI_START_Interrupt_Ack = 1;
    AI_STOP_Interrupt_Ack = 1;
    AI_Error_Interrupt_Ack = 1;
    Σ
}

```

At this point, you should clear your software copies of the registers so that they will agree with the DAQ-STC registers. The affected registers are:

```

    AI_Command_1_Register,
    AI_Command_2_Register,
    AI_Mode_1_Register,
    AI_Mode_2_Register,
    AI_Mode_3_Register,
    AI_Output_Control_Register,
    AI_Personal_Register,
    AI_START_STOP_Select_Register,
    AI_Trigger_Select_Register;
    Σ
    Reserved_One = 1;
    AI_Start_Stop = 1;
    Σ
    AI_Configuration_End = 1;
    End critical section;
}

```

You need to perform the `AI_Board_Personalize` function to bring the AITM into a known state. You can then program the AITM for any desired operation.

2.6.3.2 Board Power-up Initialization

Part of the AITM programming depends only on properties of the hardware surrounding the DAQ-STC. If you are programming a DAQ-STC that is part of a data acquisition system, refer to the document for register-level programming for information about the proper selections to make in this function.

Function `AI_Board_Personalize`

```

{
    Begin critical section;
    AI_Configuration_Start = 1;
    Σ
    AI_Source_Divide_By_2 = 0 (AI_IN_TIMEBASE1 equals IN_TIMEBASE) or
                            1 (AI_IN_TIMEBASE1 is IN_TIMEBASE divided by two);

    AI_Output_Divide_By_2 = 0 (AI_OUT_TIMEBASE equals IN_TIMEBASE) or
                            1 (AI_OUT_TIMEBASE is IN_TIMEBASE divided by
two);

    AI_CONVERT_Pulse_Timebase = 0 (pulsewidth is selected by
                                AI_CONVERT_Pulse_Width) or
                                1 (pulse width is selected by
                                AI_CONVERT_Original_Pulse);
}

```

```

AI_CONVERT_Pulse_Width = 0 (1.5–2 AI_OUT_TIMEBASE periods) or
                        1 (0.5–1 AI_OUT_TIMEBASE periods);

AI_CONVERT_Output_Select = 0 (high Z) or 1 (ground) or 2 (enable, active low) or
                        3 (enable, active high);

AI_FIFO_Flags_Polarity = 0 (active low) or 1 (active high);

AI_LOCALMUXCLK_Pulse_Width = 0 (Retransmit = 0.5–1 AI_OUT_TIMEBASE
                                periods, Read = 1.5–2 AI_OUT_TIMEBASE periods) or
                                1 (Retransmit = 0.5 AI output clock periods,
                                Read = 0.5–1 AI_OUT_TIMEBASE periods);

AI_AIFREQ_Polarity = 0 (active high) or 1 (active low);

AI_SC_TC_Output_Select = 0 (high Z) or 1 (ground) or 2 (enable, active low) or 3
                        (enable, active high);

AI_SHIFTIN_Polarity = 0 (active low) or 1 (active high);
AI_SHIFTIN_Pulse_Width = 0 (0.5–1.5 AI_OUT_TIMEBASE periods) or
                        1 (1.5–2 AI_OUT_TIMEBASE periods);
AI_EOC_Polarity = 0 (rising edge) or 1 (falling edge);
AI_SOC_Polarity = 0 (rising edge) or 1 (falling edge);

AI_Overrun_Mode = 0 (from SOC to EOC) or 1 (from SOC to the trailing edge of
SHIFTIN);
AI_SCAN_IN_PROG Output_Select = 0 (high Z) or 1 (ground) or 2 (enable, active low)
                                or 3 (enable, active high);
AI_LOCALMUX_CLK_Output_Select = 0 (high Z) or 1 (ground) or 2 (enable, active
                                low) or 3 (enable, active high);

Σ
AI_Configuration_End = 1;
End critical section;
}

```

2.6.3.3 Initialize Configuration Memory Output

Use this function to generate a LOCALMUX_CLK pulse that accesses the first value in the configuration FIFO.

```

Function AI_Initialize_Configuration_Memory_Output
{
    Begin critical section;
    AI_Configuration_Start = 1;
    If (an external MUX is present) then
    {
        AI_External_MUX_Present = 0;
    }
}

```

```

    Σ
    AI_CONVERT_Pulse = 1;
    Σ
    /*Pause here long enough that the LOCALMUX_CLK pulse generated by the /
    /*CONVERT* will have time to clock the configuration FIFO*/
    AI_External_MUX_Present = 1;
  }
Else
  {
    AI_CONVERT_Pulse = 1;
  }
AI_Configuration_End = 1;
End critical section;
}

```

2.6.3.4 Board Environment Setup

Part of the AITM programming depends only on properties of hardware surrounding the device that the DAQ-STC is on. For example, if you have an MIO board, the external hardware can be an AMUX-64T or an SCXI device. The major distinction between power-up initialization and environment setup is that power-up initialization is always the same for a device using the DAQ-STC, while the latter environmental setup may be different.

```

Function AI_Board_Environmentalize
{
  Begin critical section;
  AI_Configuration_Start = 1;
  Σ

  If (an external MUX is present) then
  {
    AI_EXTMUX_CLK_Output_Select = 2 (enable, active low) or 3 (enable, active high);
    /*Base selection on board hardware*/
    AI_EXTMUX_CLK_Pulse_Width = 0 (4.5 AI_OUT_TIMEBASE periods) or
    1 (same as LOCALMUX_CLK);
    If (more than one external MUX channel corresponds to each internal channel) then
    {
      AI_External_MUX_Present = 1;
      Σ
      AI_DIV_Load_A = number of external channels corresponding to each internal
      channel - 1;
      Σ
      AI_DIV_Load = 1;
    }
  }
Else
  {
    AI_External_MUX_Present = 0;
  }
}

```

```

    }
  }
  Else
  {
    AI_External_MUX_Present = 0;
    AI_EXTMUX_CLK_Output_Select = 0 (high Z) or 1 (forced to logic low);
    /*Base selection on board hardware*/
  }
  Σ
  AI_Configuration_End = 1;
  End critical section;
}

```

If `AI_External_MUX_Present` is set to 1, you should use the DIV counter to account for the external-to-internal multiplexing factor. In this case, you cannot use the DIV counter to generate the STOP trigger.

2.6.3.5 FIFO Request

Use this function to select the data FIFO condition on which interrupt or DMA requests will be generated.

```

Function FIFO_Request_Selection
{
  Begin critical section;
  AI_Configuration_Start = 1;
  Σ
  AI_FIFO_Mode = 0 (FIFO not empty) or 1 (FIFO half-full) or 2 (FIFO full) or
  3 (FIFO half-full until FIFO empty);
  Σ
  AI_Configuration_End = 1;
  End critical section;
}

```

2.6.3.6 Hardware Gate Programming

Use this function to enable or disable hardware and software gating. If you enable hardware gating, you also select the signal that controls the gate, the gate polarity, and the gating mode.

```

Function AI_Hardware_Gating
{
  Begin critical section;
  Σ
  AI_Configuration_Start = 1;
  If (external gating is desired) then
  {

```

```

    AI_External_Gate_Select = 1 through 10 (PFI<0..9>) or 11 through 17
                          (RTSI_TRIGGER<0..6>);
    AI_External_Gate_Polarity = 0 (active high; high enables operation) or
                              1 (active low; low enables operation);
    AI_External_Gate_Mode = 0 (free-run gating) or 1 (halt-gating mode);
  }
Else
{
    AI_External_Gate_Select = 0 (disabled);
}
}
AI_Configuration_End = 1;
End critical section;
}

```

2.6.3.7 Software Gate Operation

In order to use the software gate, the hardware gate must also be enabled. If you want to use both the software and hardware gate at the same time, configure the hardware gate and then start your application. If you only want to use the software gate, configure the hardware gate as indicated in section 2.6.3.6, *Hardware Gate Programming* with the following changes to the settings:

- `AI_External_Gate_Select = 31;`
- `AI_External_Gate_Polarity = 1;`



Note *The hardware gate must be enabled in order for the software gate to operate properly.*

To use the software gate, issue the following commands:

- To pause analog input:
`AI_Software_Gate = 1;`
- To resume analog input after pause:
`AI_Software_Gate = 0;`



Notes *Software and external gating share the gating mode; that is, `AI_External_Gate_Mode` determines the mode of operation for both hardware and software gating.*

Software and hardware gating can be used simultaneously without any special setup. The analog input operation proceeds when neither hardware nor software gate is in the pause state.

2.6.3.8 Trigger Signals

Use this function to enable or disable retriggering and to select the START1 and START2 signals (if applicable).

Function `AI_Trigger_Signals`

```

{
    Begin critical section;
    AI_Configuration_Start = 1;
    Σ
    If (retriggerable acquisition) then
        AI_Trigger_Once = 0;
    Else
        AI_Trigger_Once = 1;
    If (pretriggered acquisition) then
    {
        /*Trigger Selection*/
        AI_START1_Select = 0 (bitfield AI_START1_Pulse) or 1 through 10 (PFI<0..9>)
                        or 11 through 17 (RTSI_TRIGGER<0..6>) or
                        18 (the G_OUT signal from general-purpose counter 0);
        If (AI_START1_Select is 0) then
        {
            AI_START1_Polarity = 0;
            AI_START1_Edge = 1;
            AI_START1_Sync = 1;
        }
        Else
        {
            AI_START1_Polarity = 0 (active high or rising edge) or
                                1 (active low or falling edge);
            AI_START1_Edge = 1;
            AI_START1_Sync = 1;
        }
        /*Second Trigger Selection*/
        AI_START2_Select = 0 (bitfield AI_START2_Pulse) or 1 through 10 (PFI<0..9>)
                        or 11 through 17 (RTSI_TRIGGER<0..6>);
        If (AI_START2_Select is 0) then
        {
            AI_START2_Polarity = 0;
            AI_START2_Edge = 1;
            AI_START2_Sync = 1;
        }
        Else
        {
            AI_START2_Polarity = 0 (active high or rising edge) or
                                1 (active low or falling edge);
            AI_START2_Edge = 1;
            AI_START2_Sync = 1;
        }
    }
}

```

```

Else
{
    /*Trigger Selection*/
    AI_START1_Select = 0 (bitfield AI_START1_Pulse) or 1 through 10 (PFI<0..9>)
                    or 11 through 17 (RTSI_TRIGGER<0..6>) or
                    18 (the G_OUT signal from general-purpose counter 0);
    If (AI_START1_Select is 0) then
    {
        AI_START1_Polarity = 0;
        AI_START1_Edge = 1;
        AI_START1_Sync = 1;
    }
    Else
    {
        AI_START1_Polarity = 0 (active high or rising edge) or
                            1 (active low or falling edge);
        AI_START1_Edge = 1;
        AI_START1_Sync = 1;
    }
}
Σ
AI_Configuration_End = 1;
End critical section;
}

```

2.6.3.9 Number of Scans

Use this function to select the number of scans to be acquired. In a staged acquisition, the number of scans to be executed in each stage is contained in an array named `sc_ticks`. If the acquisition is staged, this function will load the initial value of `sc_ticks` into the SC load register to initialize the first stage. The additional values in the array are written as needed by the interrupt routine (see `AI_Staged_ISR`).

```

Function AI_Number_Of_Scans
{
    Begin critical section;
    AI_Configuration_Start = 1;
    Σ
    If (continuous acquisition) then
        AI_Continuous = 1;                               /*Infinite number of scans*/
    Else
        AI_Continuous = 0;
    If (pretriggered acquisition) then
    {
        AI_Pre_Trigger = 1;
    }
}

```

```

    Σ
    AI_SC_Load_B = minimal number of pretrigger scans to acquire - 1;
    Σ
    AI_SC_Initial_Load_Source = 1;
    AI_SC_Reload_Mode = 1 (alternate load register on TC);
}
Else
{
    AI_Pre_Trigger = 0;
    AI_SC_Initial_Load_Source = 0;
    AI_SC_Reload_Mode = 0 (same load register);
}
AI_SC_Load_A = number of posttrigger scans to acquire - 1;
Σ
AI_SC_Load = 1;
If (staged acquisition) then
{
    AI_SC_Load_B = sc_ticks[0] - 1;
    Σ
    AI_SC_Reload_Mode = 0;
    Σ
    AI_SC_Switch_Load_On_TC = 1;
}
Σ
AI_Configuration_End = 1;
End critical section;
}

```

2.6.3.10 Start of Scan

Use this function to select the scan start event. You can specify the scan rate by choosing an internally generated periodic signal to be the START signal. In a staged acquisition, the number of clocks between START in each stage is contained in an array named `si_ticks`. If the acquisition is staged, this function loads the initial value of `si_ticks` into the SI load register to initialize the first stage. The additional values in the array are written as needed by the interrupt routine (see `AI_Staged_ISR`).

Variable `si_last_load_register` introduced in this function will be used later in the functions for changing the scan rate during an acquisition (`AI_Scan_Rate_Change`) and staged acquisition (`AI_Staged_ISR`).

```

Function AI_Scan_Start
{
    Begin critical section;
    Declare variable si_last_load_register;
    AI_Configuration_Start = 1;
    Σ

```



```

If (internal START mode is selected) then
{
    AI_SI_Special_Trigger_Delay = 0;
    AI_START_Select = 0 (the internal signal SI_TC);
    AI_START_Edge = 1;
    AI_START_Sync = 1;
    AI_START_Polarity = 0;
    If (SI counter will use an internal timebase) then
    {
        AI_SI_Source_Select = 0 (AI_IN_TIMEBASE1) or 19 (IN_TIMEBASE2);
        AI_SI_Source_Polarity = 0;
    }
    Else
    {
        AI_SI_Source_Select = 1 through 10 (PFI<0..9>) or 11 through 17
        (RTSI_TRIGGER<0..6>);
        AI_SI_Source_Polarity = 0 (rising edge) or 1 (falling edge);
    }
    If (acquisition is retriggerable) then
    {
        /*You can specify a special delay from the START1 trigger to the first start of
        scan by preloading SI*/
        AI_SI_Load_A = (number of clocks from START1 to first START) - 1;
        AI_SI_Initial_Load_Source = 0;
        Σ
        AI_SI_Load = 1;
        Σ
        AI_SI_Load_A = number of clocks between each START - 1;
        AI_SI_Reload_Mode = 0;
    }
    Else if (you will not change the scan rate during the acquisition) then
    {
        /*You can specify a special delay from the START1 trigger to the first start of */
        /*a scan by using reload mode*/
        AI_SI_Load_B = number of clocks from START1 to first START - 1;
        AI_SI_Load_A = number of clocks between each START - 1;
        AI_SI_Initial_Load_Source = 1;
        Σ
        AI_SI_Load = 1;
        Σ
        AI_SI_Initial_Load_Source = 0;
        AI_SI_Reload_Mode = 6 (alternate first period on every SC_TC);
    }
    Else
    {
        /*Interval from the START1 trigger to the first start of scan is equal to the scan
        interval*/
        AI_SI_Load_A = number of clocks between each START - 1;
    }
}

```

```

AI_SI_Initial_Load_Source = 0;
AI_SI_Reload_Mode = 0;
Σ
AI_SI_Load = 1;
}
AI_SI_Write_Switch = 0;
}
Else /*External START mode is selected*/
{
/*In the single wire for START and CONVERT case, you need to set
AI_START_Sync to 0*/
/*The single wire case is defined by START and CONVERT coming from a
single external source*/
/*with the same polarity*/
/*In other cases, it is safe to set AI_START_Sync to 1*/
/*It is always safe to set AI_START_Edge to 1*/
If (START source and CONVERT source are equal) AND (START and
CONVERT have the same polarity) then
{
AI_START_Select = 1 through 10 (PFI<0..9>) or 11 through 17
(RTSI_TRIGGER<0..6>) or 18 (bitfield
AI_START_Pulse) or 19 (the G_OUT signal from
general-purpose counter 0);
AI_START_Sync = 0;
AI_START_Edge = 1;
AI_START_Polarity = 0 (active high or rising edge) or
1 (active low or falling edge);
}
Else
{
AI_START_Select = 1 through 10 (PFI<0..9>) or 11 through 17
(RTSI_TRIGGER<0..6>) or 18 (bitfield
AI_START_Pulse) or 19 (the G_OUT signal from
general-purpose counter 0);
AI_START_Sync = 1;
AI_START_Edge = 1;
AI_START_Polarity = 0 (active high or rising edge) or
1 (active low or falling edge);
}
If (SI Special Trigger Delay is used) then
{
AI_SI_Special_Trigger_Delay = 1;
AI_SI_Write_Switch = 0;
If (an internal timebase is used) then
{
AI_SI_Source_Select = 0 (AI_IN_TIMEBASE1) or 19
(IN_TIMEBASE2);
AI_SI_Source_Polarity = 0;
}
}
}
}

```

```

    }
    Else
    {
        AI_SI_Source_Select = 1 through 10 (PFI<0..9>) or 11 through 17
        (RTSI_TRIGGER<0..6>);
        AI_SI_Source_Polarity = 0 (rising edge) or 1 (falling edge);
    }
    AI_SI_Load_A = (minimum number of clocks from START1 to first
    START) - 1;
    AI_SI_Initial_Load_Source = 0;
    Σ
    AI_SI_Load = 1;
}
Else
AI_SI_Special_Trigger_Delay = 0;
}
If (staged acquisition) then
{
    AI_SI_Load_B = si_ticks[0] - 1;
    AI_SI_Reload_Mode = 0;
    AI_SI_Switch_Load_On_SC_TC = 1;
    si_last_load_register = B;
}
Else
{
    si_last_load_register = A;
}
Σ
AI_Configuration_End = 1;
End critical section;
}

```

2.6.3.11 End of Scan

Use this function to select the end-of-scan event. On a typical MIO board, the end-of-scan event comes from the configuration memory. On a typical board without configuration memory, the end-of-scan event is generated by the DIV counter. Notice that the DAQ-STC cannot simultaneously generate end-of-scan events and timing for an external signal multiplexer.

Function AI_Scan_End

```

{
    Begin critical section;
    AI_Configuration_Start = 1;
    Σ
    If (the end of scan is coming from the outside, either PFI or Configuration FIFO) then
    {

```

```

AI_STOP_Select = 1 through 10 (PFI<0..9>) or 11 through 17
(RTSI_TRIGGER<0..6>) or 19 (signal present on the AI_STOP_IN pin);
AI_STOP_Edge = 0;
AI_STOP_Polarity = 0 (active high or rising edge) or 1 (active low or falling edge);
AI_STOP_Sync = 1;
/*If you have a vary fast board, you may need to use an asynchronous STOP
(AI_STOP_Sync = 0)*/
}
Else
{
  If (more than one channel per scan) then
  {
    /*DIV counter is used as the STOP source*/
    AI_STOP_Select = 0 (DIV_TC);
    AI_STOP_Sync = 1;
    AI_STOP_Edge = 0;
    AI_STOP_Polarity = 0;
    AI_DIV_Load_A = number of channels per scan - 1;
    Σ
    AI_DIV_Load = 1;
  }
  Else
  {
    /*Force START signal to be always high*/
    AI_STOP_Select = 31 (logic low);
    AI_STOP_Sync = 0;
    AI_STOP_Edge = 0;
    AI_STOP_Polarity = 1;
  }
}
Σ
AI_Configuration_End = 1;
End critical section;
}

```

2.6.3.12 Convert Signal

Use this function to select the CONVERT signal. You can specify the channel rate by choosing an internally generated periodic event.

```

Function AI_CONVERT_Signal
{
  Begin critical section;
  AI_Configuration_Start = 1;
  Σ
  If (internal CONVERT mode is selected) then
  {

```

```

AI_SC_Gate_Enable = 0;
AI_Start_Stop_Gate_Enable = 0;
If (SI2 counter will use internal time) then
{
  /*If you want both SI and SI2 to use AI_IN_TIMEBASE1, you must program
  SI to select*/
  /*AI_IN_TIMEBASE1 and program SI2 to select the SI source*/
  If (SI2 will use AI_IN_TIMEBASE1) then
  {
    If (internal START mode) AND (SI will use AI_IN_TIMEBASE1) then
      AI_SI2_Source_Select = 0 (same signal selected as SI source);
    Else
      AI_SI2_Source_Select = 1 (AI_IN_TIMEBASE1);
  }
  Else
  {
    /*If you want SI2 to use IN_TIMEBASE2, program the SI2 counter to */
    /*use the same timebase as the SI counter, and then program the SI */
    /*counter to use IN_TIMEBASE2. This will work well in one of the */
    /*following two cases: you are not using SI at all, or you are using */
    /*SI and it uses IN_TIMEBASE2*/
    AI_SI2_Source_Select = 0 (same signal selected as SI source);
    AI_SI_Source_Select = 19 (IN_TIMEBASE2);
    AI_SI_Source_Polarity = 0;
  }
}
Else
{
  /*You want to use SI2 and you want to use one of the external timebases. */
  /*Program the SI2 counter to use the same timebase as the SI counter, */
  /*and program the SI counter to use the external timebase of your choice. */
  /*This will work well in one of the following are not using SI at all, or you*/
  /*are using SI and it uses the timebase you have selected here*/

  AI_SI2_Source_Select = 0 (same signal selected as SI source);
  AI_SI_Source_Select = 1 through 10 (PFI<0..9>) or
                        11 through 17 (RTSI_TRIGGER<0..6>);
  AI_SI_Source_Polarity = 0 (rising edge) or 1 (falling edge);
}
AI_SI2_Load_A = number of clocks from START to the first CONVERT - 1;
AI_SI2_Initial_Load_Source = 0;
AI_SI2_Load_B = number of clocks between two CONVERT signals within
a scan - 1;
AI_SI2_Reload_Mode = 1 (alternate first period on every STOP);
Σ
AI_SI2_Load = 1;
Σ
AI_SI2_Initial_Load_Source = 1;

```

```

}
Else
{
    AI_SC_Gate_Enable = 1;
    AI_Start_Stop_Gate_Enable = 1;
    AI_CONVERT_Source_Select = 1 through 10 (PFI<0..9>) or
                            11 through 17 (RTSI_TRIGGER<0..6>) or
                            19 (the G_OUT signal from general-purpose counter 0);
    AI_CONVERT_Source_Polarity = 0 (falling edge) or 1 (rising edge);
}
Σ
AI_Configuration_End = 1;
End critical section;
}

```

Another feature the DAQ-STC provides in the external CONVERT mode is SC_GATE (SC Counter Gate). Similar to the STST_GATE, the SC_GATE provides a mechanism for blocking the external CONVERT pulses. If you set AI_Start_Stop_Gate_Enable to 0 in the external CONVERT section of the AI_Convert_Signal function, the SC_GATE is selected. The SC_GATE enables the external CONVERT pulses whenever the SC counter is enabled to count and blocks the external CONVERT pulses whenever the SC counter is not enabled to count.

2.6.3.13 Enable Interrupts

Use this function to enable the AITM to generate interrupts.

```

Function AI_Interrupt_Enable
{
    AI_FIFO_Interrupt_Enable = 0 (disabled) or 1 (enabled);
    AI_START_Interrupt_Enable = 0 (disabled) or 1 (enabled);
    /*START interrupt must be enabled in order for the STOP interrupt to operate*/
    If (AI_START_Interrupt_Enable is 1) then
    {
        AI_STOP_Interrupt_Enable = 0 (disabled) or 1 (enabled);
    }
    Else
    {
        AI_STOP_Interrupt_Enable = 0 (disabled);
    }
    AI_SC_TC_Interrupt_Enable = 0 (disabled) or 1 (enabled);
    AI_START1_Interrupt_Enable = 0 (disabled) or 1 (enabled);
    AI_START2_Interrupt_Enable = 0 (disabled) or 1 (enabled);
    AI_Error_Interrupt_Enable = 0 (disabled) or 1 (enabled);
}

```

To generate interrupts, you must also program the interrupt control module. Refer to Chapter 8, *Interrupt Control*, for more information on programming the interrupt control module. To use interrupts, refer also to section 2.6.8, *Analog Input-Related Interrupts*.

2.6.3.14 Arming

Use this function to arm the analog input counters.

```
Function AI_Arming
{
    Declare variable arm_si, arm_si2;
    If (single scan) then
    {
        AI_DIV_Arm = 1;
        AI_End_On_End_Of_Scan = 1;
    }
    If (internal START mode) OR (SI special trigger delay will be used) then
        arm_si = 1;
    Else
        arm_si = 0;
    If (internal CONVERT mode) then
        arm_si2 = 1;
    Else
        arm_si2 = 0;
    AI_SC_Arm = 1;           /*You must set these four bitfields in a single write*/
    AI_SI_Arm = arm_si;
    AI_SI2_Arm = arm_si2;
    AI_DIV_Arm = 1;
}
}
```

2.6.3.15 Starting the Acquisition

Use this function to initiate an analog input operation if you have selected software pretrigger (for pretriggered operation) or software posttrigger (for non-pretriggered operation). This function does not do anything unless you have selected software pretrigger or posttrigger.

```
Function AI_Start_The_Acquisition
{
    If (acquisition is pretriggered) then
    {
        If (software pretrigger) then
            AI_START1_Pulse = 1;
        }
    Else
    {
```

```

        If (software posttrigger) then
            AI_START1_Pulse = 1;
        }
    }

```

2.6.3.16 Analog Input Program

The previous sections listed functions that you can use to configure the AITM. This section shows how to organize these functions to implement a general analog input operation. You can use the following sequence of functions to program the AITM for any analog input operation.

```

{
    /*Refer to Chapter 10, Miscellaneous Functions, to set up your timebase*/
    /*Before beginning the programming sequence, you may want to program the */
    /*Configuration FIFO and flush the AI data FIFO, if this is appropriate for your DAQ */
    /*device*/
    Call AI_Reset_All;
    Call AI_Board_Personalize;
    Call AI_Initialize_Configuration_Memory_Output;
    Call AI_Board_Environmentalize;
    Call AI_FIFO_Request_Selection;
    Call AI_Hardware_Gating;
    Call AI_Trigger_Signals;
    Call AI_Number_Of_Scans;
    Call AI_Scan_Start;
    Call AI_Scan_End;
    Call AI_CONVERT_Signal;
    /*You may want to clear the AI data FIFO, if applicable. If you are using an external */
    /*multiplexer, such as the AMUX-64T, you must program it here*/
    /*If you are using an external track-and-hold module that requires the presence of the
    /*SCAN_IN_PROG signal on PFI7, you must program it here*/
    Call AI_Interrupt_Enable;
    Call AI_Arming;
    Call AI_Start_The_Acquisition;
}

```

2.6.4 Single Scan

To acquire exactly one scan of input, a special programming sequence is required, as follows.

```

{
    Use the programming sequence from section 2.6.3.16, Analog Input Program.
    In the function AI_Scan_Start, set
        AI_START_Select = 31 (ground);
        AI_START_Polarity = 0;
}

```

After the programming sequence is complete, issue the following commands:

```

AI_START_Polarity = 1;
Σ
AI_START_Polarity = 0;
}

```

2.6.5 Change Scan Rate during an Acquisition

You can change the scan rate if you do not have special requirements on the timing for the START1 to START in retriggerable analog input or if the acquisition is not retriggerable. This will not work in the case of retriggerable analog input with nondefault START1 to START timing. Assume that the sequence of START rates is stored in the array `si_ticks`, and the variable `si_ticks_pointer` indicates the current position in the array. You can use the following function to change the scan rate.

Function `AI_Scan_Rate_Change`

```

{
  If (acquisition is not retriggerable) OR (you will change the scan rate during an
  acquisition) then
  {
    If (si_last_load_register is 0) then
    {
      /*If the last load was from the last load register written to, it is all right to */
      /*change the rate Otherwise, you cannot change the rate*/
      If (AI_SI_Next_Load_Source_St is 0) then
      {
        AI_SI_Load_B = si_ticks[si_ticks_pointer] - 1;
        si_ticks_pointer += 1;
        si_last_load_register = 1;
        If (switch SI load registers on TC) then
          AI_SI_Switch_Load_On_TC = 1;
        Else
          AI_SI_Switch_Load_On_SC_TC = 1;
      }
    }
    Else
      Scan rate change cannot be performed;
  }

  Else
  {
    If (AI_SI_Next_Load_Source_St is 1) then
    {
      AI_SI_Load_A = si_ticks[si_ticks_pointer] - 1;
      si_ticks_pointer += 1;
      si_last_load_register = 0;
      If (switch SI load registers on TC) then
        AI_SI_Switch_Load_On_TC = 1;
    }
  }
}

```

```

        Else
            AI_SI_Switch_Load_On_SC_TC = 1;
        }
    Else
        Scan rate change cannot be performed;
    }
}
}

```

2.6.6 Staged Acquisition

In a staged acquisition, software implements more than one posttrigger acquisition sequence, each having unique timing parameters. The number of scans to be executed in each stage is contained in an array named `sc_ticks`. The variable `sc_ticks_pointer` is a pointer into the array and should be initialized to 1. The number of scans for the first two posttrigger acquisition sequences is programmed in the `AI_Number_Of_Scans` function.

The number of clocks between `START` in each stage is contained in an array named `si_ticks`. The variable `si_ticks_pointer` is a pointer into the array and should be initialized to 1. The number of clocks for the first two posttrigger acquisition sequences is programmed in the `AI_Scan_Start` function.

The variable `si_last_load_register` indicates which load register was accessed most recently and is initialized in the `AI_Scan_Start` function.

The `SC_TC` interrupt notifies the CPU that the current acquisition sequence is complete so that the ISR can program the parameters for the next acquisition sequence. After the parameters are loaded, the ISR checks for an `SC_TC` error. An `SC_TC` error occurs if the parameters for the next acquisition sequence are not written before the end of the current acquisition sequence.

Use the following function as an ISR for staged acquisitions.

```

Function AI_Staged_ISR
{
    /*If the last load was from the last load register written to, it is all right to change the */
    /*rate. Otherwise, you cannot change the rate*/
    If (si_last_load_register is 0) then
    {
        AI_SI_Load_B = si_ticks[si_ticks_pointer] - 1;
        If (sc_ticks[sc_ticks_pointer] is 0) then
        {
            AI_End_On_SC_TC = 1;
            AI_SC_TC_Interrupt_Enable = 0;
        }
    }
    Else
    {

```

```

        AI_SC_Load_B = sc_ticks[si_ticks_pointer] - 1;
        AI_SI_Switch_Load_On_SC_TC = 1;
        AI_SC_Switch_Load_On_TC = 1;
    }
    si_ticks_pointer += 1;
    si_last_load_register = 1;
}
Else
{
    AI_SI_Load_A = si_ticks[si_ticks_pointer] - 1;
    If (sc_ticks[sc_ticks_pointer] is 0) then
    {
        AI_End_On_SC_TC = 1;
        AI_SC_TC_Interrupt_Enable = 0;
    }
    Else
    {
        AI_SC_Load_A = sc_ticks[si_ticks_pointer] - 1;
        AI_SI_Switch_Load_On_SC_TC = 1;
        AI_SC_Switch_Load_On_TC = 1;
    }
    si_ticks_pointer += 1;
    si_last_load_register = 0;
}
AI_SC_TC_Interrupt_Ack = 1;
/*Check for interrupt latency problems*/
If (AI_SC_TC_Error_St is 0) then
{
    AI_SC_TC_Error_Confirm = 1;
}
Else
{
    Inform user that an SC_TC error has occurred;
}
}

```

2.6.7 Master/Slave Operation Considerations

You can use several DAQ-STCs for synchronized analog input operation. To do this, connect the trigger signal to the trigger input of the master DAQ-STC. You also connect the output equivalents of the triggers from the master DAQ-STC to the slave DAQ-STCs. You may use the RTSI connector to do this.



Note *You must perform the programming sequence described in section [10.8.1, Programming Clock Distribution](#), before you execute the sequence given here.*

Use the following programming sequence:

```

{
  AI_START1_Disable = 1 for the master DAQ-STC;
  AI_Delayed_START1 = 1 for the master DAQ-STC;
  AI_Delayed_START1 = 0 for all the slave DAQ-STCs;
  If (pretriggered AI) then
  {
    AI_Delayed_START2 = 1 for the master DAQ-STC;
    AI_Delayed_START2 = 0 for all the slave DAQ-STCs;
  }

  Perform the usual set-up sequence for each DAQ-STC;
  /*See programming sequence in Analog Input Program*/

  AI_START1_Disable = 0 for the master DAQ-STC;
}

```

2.6.8 Analog Input-Related Interrupts

The DAQ-STC is designed to be used primarily with a system that supports interrupts. This section contains instructions on programming the DAQ-STC when it is used in an environment that supports interrupts.

If the DAQ-STC you want to program is part of a system in which interrupts do not exist, you can use programming sequences intended for ISRs directly in your application, coupled with the programming technique known as polling. If you use polling, your application must periodically read relevant status bitfields and use the values obtained to decide whether to execute a programming sequence equivalent to the ISRs.

When the DAQ-STC is used in a system in which interrupts can be handled, but the handling is prohibitively slow, you can use the polling technique. However, your system will be devoted entirely to one application.

For more detailed discussion of interrupts and polling, refer to any introductory computer architecture textbook. Information on interrupts and polling can also be found in National Instruments Application Note 010: *Programming Interrupts for Data Acquisition on 80x86-Based Computers*.

Interrupts related to analog input can be generated on the following analog input conditions:

- Error (overflow or overrun)
- START
- STOP
- START1
- START2

- SC_TC
- FIFO condition

Basic actions required to enable, detect, and acknowledge the analog input-related interrupts follow.

Error

To enable:	AI_Error_Interrupt_Enable
To recognize:	AI_Overflow_St and AI_Overrun_St
To acknowledge (and clear):	AI_Error_Interrupt_Ack

START

To enable:	AI_START_Interrupt_Enable
To recognize:	AI_START_St
To acknowledge (and clear):	AI_START_Interrupt_Ack

STOP

To enable:	AI_STOP_Interrupt_Enable and AI_START_Interrupt_Enable
To recognize:	AI_STOP_St
To acknowledge (and clear):	AI_STOP_Interrupt_Ack

START1

To enable:	AI_START1_Interrupt_Enable
To recognize:	AI_START1_St
To acknowledge (and clear):	AI_START1_Interrupt_Ack

START2

To enable:	AI_START2_Interrupt_Enable
To recognize:	AI_START2_St
To acknowledge (and clear):	AI_START2_Interrupt_Ack

SC_TC

To enable:	AI_SC_TC_Interrupt_Enable
To recognize:	AI_SC_TC_St
To acknowledge (and clear):	AI_SC_TC_Interrupt_Ack

FIFO Condition

To enable:	AI_FIFO_Interrupt_Enable
To select condition use:	AI_FIFO_Mode
To recognize:	AI_FIFO_Full_St, AI_FIFO_Half_Full_St, and AI_FIFO_Empty_St

To clear: You must change the FIFO state by dealing with the FIFO

All interrupts related to analog input are in interrupt group A.

To select the interrupt line to be used,
 Interrupt_A_Output_Select = 0 through 7;
 Interrupt_A_Enable = 1;

To determine quickly if any of the group A interrupts have occurred, use Interrupt_A_St.



Notes *To select interrupt output polarity, use Interrupt_Output_Polarity. This selection depends on the board hardware design.*

Pass_Through_0_Interrupt is also in interrupt group A.

For more detailed information about the conditions that generate an interrupt, refer to section [2.8.4, Interrupt Control](#).

2.6.9 Bitfield Descriptions

Bits in the register bit maps are organized into bitfields. A bitfield can contain one or more bits. Only bits with contiguous locations within a register can belong to a bitfield. The high and low pairs of load and save registers for 24-bit counters are also treated as bitfields. The AITM-related bitfields are described below. Not all bitfields referred to in section [2.6, Programming Information](#), are listed here. To locate a particular bitfield description within this manual, refer to Appendix B, [Register Information](#).

AI_AIFREQ_Polarity

bit: 4 **type:** Write **in:** AI_Personal_Register **address:** 77

This bit selects the polarity of the AIFREQ output signal:

- 0: Active high.
- 1: Active low.

AI_Analog_Trigger_Reset

bit: 14 **type:** Strobe **in:** AI_Command_1_Register **address:** 8

This bit clears the hysteresis registers in the analog trigger circuit. Set this bit to 1 at the time you arm the analog input counters if you want to use analog triggering in hysteresis mode for any analog input signal. Before setting this bit to 1, make sure that the analog trigger is not being used by any other part of the DAQ-STC. You should not set this bit to 1 in any other case. This bit is cleared automatically.

AI_Configuration_End

bit: 8 **type:** Strobe **in:** Joint_Reset_Register **address:** 72

This bit clears AI_Configuration_Start, which holds the analog input circuitry in reset to prevent glitches on the output pins during configuration. You should set this bit to 1 when ending the configuration of the analog input circuitry. This bit is cleared automatically.

Related bitfields: AI_Configuration_Start.

AI_Configuration_Start

bit: 4 **type:** Strobe **in:** Joint_Reset_Register **address:** 72

This bit holds the analog input circuitry in reset to prevent glitches on the output pins during configuration. The following analog input circuits are affected:

- Output circuits
- Counter control circuits
- Trigger circuits
- Interrupt circuits

The following circuits are also affected:

- Interrupt_A_Ack_Register
- Autoacknowledge circuit for general-purpose counter 0.

You should set this bit to 1 when beginning the configuration of the analog input circuitry. By doing this you ensure that no spurious glitches appear on the output pins and on the internal circuit components. If you do not set this bit to 1, the DAQ-STC may behave erroneously. This bit is cleared by setting AI_Configuration_End to 1. Related bitfields: AI_Configuration_End.

AI_Config_Memory_Empty_St

bit: 6 **type:** Read **in:** Joint_Status_2_Register **address:** 29

This bit indicates the state of the MUXFEF input pin (after the polarity selection). Related bitfields: AI_FIFO_Flags_Polarity.

AI_Continuous

bit: 1 **type:** Write **in:** AI_Mode_1_Register **address:** 12

This bit determines the behavior of the SC, SI, SI2, and DIV counters during SC_TC:

- 0: If AI_Pre_Trigger is 0, the counters will return to idle on the first SC_TC. If AI_Pre_Trigger is 1, the counters will return to idle on the second SC_TC.
- 1: The counters will ignore SC_TC.

Set this bit to 0 to select the pretrigger or posttrigger acquisition modes if you want to acquire a predetermined number of scans. Set this bit to 1 to select the continuous acquisition mode if you wish to continuously acquire data or to perform staged analog input. You can use AI_End_On_End_Of_Scan and AI_End_On_SC_TC to stop an analog input operation in the continuous acquisition mode. Related bitfields: AI_End_On_End_Of_Scan, AI_End_On_SC_TC, AI_Pre_Trigger.

AI_CONVERT_Original_Pulse

bit: 9 **type:** Write **in:** AI_Personal_Register **address:** 77

If AI_CONVERT_Pulse_Timebase is 1, this bit determines the pulsewidth of the CONVERT and PFI2/CONV signals. The pulsewidth of the CONVERT signals is:

- 0: Equal to the pulsewidth of the signal used to generate the CONVERT signal, with the maximum pulsewidth determined by AI_CONVERT_Pulse_Width.
- 1: Equal to the pulsewidth of the signal used to generate the CONVERT signal.

Related bitfields: AI_CONVERT_Pulse_Timebase, AI_CONVERT_Pulse_Width.

AI_CONVERT_Output_Select

bits: <0..1> **type:** Write **in:** AI_Output_Control_Register **address:** 60

This bit enables and selects the polarity of the CONVERT output signal:

- 0: High Z.
- 1: Ground.
- 2: Enable, active low.
- 3: Enable, active high.

This bitfield also selects the polarity of the PFI2/CONV output signal, if enabled for output:

- 0: Active low.
- 1: Ground.
- 2: Active low.
- 3: Active high.

Related bitfields: BD_2_Pin_Dir.

AI_CONVERT_Pulse

bit: 0 **type:** Strobe **in:** AI_Command_1_Register **address:** 8

Setting this bit to 1 produces a pulse on the CONVERT and PFI2/CONV output signals, if the signals are enabled for output and if CONVERT pulses are not blocked. CONVERT pulses can be blocked by the external gate, the software gate, the start/stop gate, or the SC gate. The pulsewidths of the output signals are determined by AI_CONVERT_Pulse_Width. This bit is cleared automatically. This bit is disabled when AI_Configuration_Start is set to 1. Related bitfields: AI_CONVERT_Output_Select, BD_2_Pin_Dir, AI_CONVERT_Pulse_Width.

AI_CONVERT_Pulse_Timebase

bit: 11 **type:** Write **in:** AI_Personal_Register **address:** 77

This bit determines how the pulsewidths of the CONVERT and PFI2/CONV signals are selected:

- 0: Selected by AI_CONVERT_Pulse_Width.
- 1: Selected by AI_CONVERT_Original_Pulse.

Related bitfields: AI_CONVERT_Pulse_Width, AI_CONVERT_Original_Pulse.

AI_CONVERT_Pulse_Width**bit:** 10 **type:** Write **in:** AI_Personal_Register **address:** 77

If AI_CONVERT_Pulse_Timebase is 0, this bit determines the pulsewidth of the CONVERT and PFI2/CONV output signals. If AI_CONVERT_Pulse_Timebase is 1 and AI_CONVERT_Original_Pulse is 0, this bit determines the maximal pulsewidth of the CONVERT and PFI2/CONV signals (so that the pulsewidth is equal to the shorter of this pulsewidth and the original signal pulsewidth). The pulsewidths are as follows:

- 0: 1.5–2 AI_OUT_TIMEBASE periods.
- 1: 0.5–1 AI_OUT_TIMEBASE periods.

Related bitfields: AI_CONVERT_Pulse_Timebase, AI_CONVERT_Original_Pulse.

AI_CONVERT_Source_Polarity**bit:** 5 **type:** Write **in:** AI_Mode_1_Register **address:** 12

This bit selects the of active edge of the CONVERT source (the signal that is selected by AI_CONVERT_Source_Select):

- 0: Falling edge.
- 1: Rising edge.

You must set this bit to 0 in the internal CONVERT mode. Related bitfields: AI_CONVERT_Source_Select.

AI_CONVERT_Source_Select**bits:** <11..15> **type:** Write **in:** AI_Mode_1_Register **address:** 12

This bitfield selects the CONVERT source:

- 0: The internal signal SI2_TC, inverted..
- 1–0: PFI<0..9>.
- 11–17: RTSI_TRIGGER<0..6>.
- 19: The internal signal GOUT from general-purpose counter 0.
- 31: Logic low.

When you set this bit to 0, the DAQ-STC is in the internal CONVERT mode. When you select any other signal as the CONVERT source, the DAQ-STC is in the external CONVERT mode.

AI_Delayed_START**bit:** 9 **type:** Write **in:** AI_Mode_3_Register **address:** 87

This bit determines when the START1 trigger is used by the AITM:

- 0: Use START1 trigger immediately.
- 1: Delay the START1 trigger by synchronizing it to the CONVERT source.

Set this bit to 1 in the master ASIC during master/slave trigger. The slave ASIC(s) can then synchronize to the same clock as the master by triggering on the START1 signal that is output from the master.

AI_Delayed_START2**bit:** 10 **type:** Write **in:** AI_Mode_3_Register **address:** 87

This bit determines when the START2 trigger is used by the AITM:

- 0: Use START2 trigger immediately.
- 1: Delay the START2 trigger by synchronizing it to the CONVERT source.

Set this bit to 1 in the master ASIC during master/slave trigger. The slave ASIC can then synchronize to the same clock as the master by triggering on the START2 signal that is output from the master.

AI_Delay_START**bit:** 14 **type:** Write **in:** AI_Mode_3_Register **address:** 87

This bit selects the internal clock that synchronizes the START trigger when START synchronization is selected:

- 0: START synchronizes to SI2_SRC (internal CONVERT) or FSCLK (external CONVERT).
- 1: START synchronizes to SC_SRC.

Since the clock SC_SRC is internally delayed relative to SI2_SRC and FSCLK, setting this bit to 1 provides additional margin for the external START to reach the synchronization flip-flop, but allows less margin for the output of the synchronization flip-flop to reach the counter control circuits. You should normally set this bit to 0.

Related bitfields: AI_START_Sync.

AI_Disarm**bit:** 13 **type:** Strobe **in:** AI_Command_1_Register **address:** 8

Setting this bit to 1 asynchronously disarms the SC, SI, SI2, and DIV counters. This command should only be used to disarm idle counters. To disarm non-idle counters, use AI_Software_Reset. This bit is cleared automatically.

Related bitfields: AI_Software_Reset.

AI_DIV_Arm**bit:** 8 **type:** Strobe **in:** AI_Command_1_Register **address:** 8

This bit arms the DIV counter. The counter remains armed (and the bit remains set) until it is disarmed, either by hardware or by setting AI_Disarm to 1. Related bitfields: AI_DIV_Armed_St, AI_Disarm.

AI_DIV_Armed_St**bit:** 14 **type:** Read **in:** AI_Status_2_Register **address:** 5

This bit indicates whether the DIV counter is armed:

- 0: Disarmed.
- 1: Armed.

Related bitfields: AI_DIV_Arm.

AI_DIV_Load**bit:** 7 **type:** Strobe **in:** AI_Command_1_Register **address:** 8

If the DIV counter is disarmed, this bit loads the DIV counter with the contents of the DIV load register. If the DIV counter is armed, writing to this bit has no effect. This bit is cleared automatically.

AI_DIV_Load_A**bits:** <0..15> **type:** Write **in:** AI_DIV_Load_A_Register **address:** 64

This bitfield is the load register for the DIV counter. The DIV counter loads the value contained in this bitfield on AI_DIV_Load and on DIV_TC. Related Bitfields: AI_DIV_Load.

AI_DIV_Q_St**bit:** 13 **type:** Read **in:** AI_Status_2_Register **address:** 5

This bit reflects the state of the DIV control circuit:

- 0: WAIT.
- 1: CNT.

See section 2.8, *Detailed Description*, for more information on the DIV control circuit.

AI_DIV_Save_Value**bits:** <0..15> **type:** Read **in:** AI_DIV_Save_Register **address:** 26

This bitfield reflects the contents of the DIV counter. Reading from this bitfield while the DIV counter is counting may result in an erroneous value.

AI_End_On_End_Of_Scan**bit:** 14 **type:** Strobe **in:** AI_Command_2_Register **address:** 4

Setting this bit to 1 disarms the SC, SI, SI2, and DIV counters at the next STOP. You can use this bit to stop the acquisition in continuous acquisition mode. This bit is cleared automatically. Related bitfields: AI_Continuous.

AI_End_On_SC_TC**bit:** 15 **type:** Strobe **in:** AI_Command_2_Register **address:** 4

Setting this bit to 1 disarms the SC, SI, SI2, and DIV counters at the next SC_TC. You can use this bit to stop the acquisition in continuous acquisition mode. This bit is cleared automatically. Related bitfields: AI_Continuous.

AI_EOC_Polarity**bit:** 14 **type:** Write **in:** AI_Personal_Register **address:** 77

This bit determines which edge of the EOC input signal indicates end of conversion:

- 0: Rising edge.
- 1: Falling edge.

Related bitfields: AI_EOC_St.

AI_EOC_St**bit:** 4 **type:** Read **in:** Joint_Status_2_Register **address:** 29

This bit indicates the state of the EOC pin (after the polarity selection). This bit is useful for device diagnostic applications. Related bitfields: AI_EOC_Polarity.

AI_Error_Interrupt_Ack**bit:** 13 **type:** Strobe **in:** Interrupt_A_Ack_Register **address:** 2

Setting this bit to 1 clears AI_Overflow_St and AI_Overrun_St and acknowledges the Error interrupt request (in either interrupt bank) if the Error interrupt is enabled. This bit is cleared automatically. Related bitfields: AI_Overflow_St, AI_Overrun_St, AI_Error_Interrupt_Enable.

AI_Error_Interrupt_Enable**bit:** 5 **type:** Write **in:** Interrupt_A_Enable_Register **address:** 73

This bit enables the Error interrupt:

- 0: Disabled.
- 1: Enabled.

The Error interrupt is generated on the detection of an overrun or overflow error condition.

AI_Error_Second_Irq_Enable**bit:** 5 **type:** Write **in:** Second_Irq_A_Enable_Register **address:** 74

This bit enables the Error interrupt in the secondary interrupt bank:

- 0: Disabled.
- 1: Enabled.

The Error interrupt is generated on the detection of an overrun or overflow error condition.

AI_External_Gate_Mode**bit:** 8 **type:** Write **in:** AI_Mode_3_Register **address:** 87

This bit determines the gating mode, if gating is enabled.

- 0: Free-run gating mode.
- 1: Halt-gating mode.

Refer to section 2.4.4, *Gating*, for more information on gating modes. Related bitfields: AI_External_Gate_Select, AI_Software_Gate.

AI_External_Gate_Polarity**bit:** 5 **type:** Write **in:** AI_Mode_3_Register **address:** 87

This bit selects the polarity of the external gate signal:

- 0: Active high (high enables operation).
- 1: Active low (low enables operation).

AI_External_Gate_Select**bits:** <0..4> **type:** Write **in:** AI_Mode_3_Register **address:** 87

This bitfield enables and selects the external gate:

- 0: External gate disabled.
- 1–10: PFI<0..9>.
- 11–17: RTSI_TRIGGER<0..6>.
- 31: Logic low.

You can use the external gate to pause an analog input operation in progress. Refer to section 2.4.4, *Gating*, for more information on external gating. Related bitfields: AI_External_Gate_Polarity.

AI_External_Gate_St**bit:** 10 **type:** Read **in:** Joint_Status_1_Register **address:** 27

This bit indicates whether the external gate and the software gate are set to enable analog input operation:

- 0: Pause analog input operation.
- 1: Enable analog input operation.

Related bitfields: AI_External_Gate_Select, AI_Software_Gate.

AI_External_MUX_Present**bit:** 12 **type:** Write **in:** AI_Mode_2_Register **address:** 13

This bit determines when the LOCALMUX_CLK output signal pulses:

- 0: Pulse on every CONVERT.
- 1: Pulse only on CONVERTs that occur during DIV_TC.

This bit allows you to use the DIV counter for LOCALMUX_CLK signal control. This is useful if one or more external multiplexers, such as an AMUX-64T or SCXI, are connected to the board the DAQ-STC is on. You should set this bit to 0 if no external multiplexers are present or if each external channel corresponds to one internal channel. You should set this bit to 1 if one or more external multiplexers are present and if you are multiplexing more than one external channel onto each internal channel. If this bit is set to 1, the DIV counter must be used to determine the number of EXTMUX_CLK pulses that will correspond to one LOCALMUX_CLK pulse.

AI_EXTMUX_CLK_Output_Select**bits:** <6..7> **type:** Write **in:** AI_Output_Control_Register **address:** 60

This bit enables and selects polarity for the EXTMUX_CLK output signal:

- 0: High Z.
- 1: Ground.
- 2: Enable, active low.
- 3: Enable, active high.

AI_EXTMUX_CLK_Pulse**bit:** 3 **type:** Strobe **in:** AI_Command_1_Register **address:** 8

Setting this bit to 1 produces a pulse on the EXTMUX_CLK output signal if the output is enabled. The pulsewidth is determined by AI_EXTMUX_CLK_Pulse_Width. This bit is cleared automatically. Related bitfields: AI_EXTMUX_CLK_Output_Select, AI_EXTMUX_CLK_Pulse_Width.

AI_EXTMUX_CLK_Pulse_Width**bit:** 6 **type:** Write **in:** AI_Personal_Register **address:** 77

This bit selects the pulsewidth and assertion time of the EXTMUX_CLK output signal:

- 0: Pulsewidth is 4.5 AI_OUT_TIMEBASE periods. EXTMUX_CLK trails the LOCALMUX_CLK pulse by 0.5–1.5 AI_OUT_TIMEBASE periods.
- 1: Pulsewidth is equal to the pulsewidth of the LOCALMUX_CLK read pulse selected by AI_LOCALMUX_CLK_Pulse_Width. EXTMUX_CLK and LOCALMUX_CLK are asserted at the same time.

Related bitfields: AI_LOCALMUX_CLK_Pulse_Width.

AI_FIFO_Empty_St**bit:** 12 **type:** Read **in:** AI_Status_1_Register **address:** 2

This bit reflects the state of the AIFEF pin (after the polarity selection), which indicates the AI data FIFO status:

- 0: Not empty.
- 1: Empty.

Related bitfields: AI_FIFO_Flags_Polarity.

AI_FIFO_Flags_Polarity**bit:** 8 **type:** Write **in:** AI_Personal_Register **address:** 77

This bit selects the polarity of the AI data FIFO flags (input signals AIFFF, AIFHF, AIFEF, and MUXFEF):

- 0: Active low.
- 1: Active high.

Related bitfields: AI_FIFO_Empty_St, AI_FIFO_Full_St, AI_FIFO_Half_Full_St, AI_Config_Memory_Empty_St.

AI_FIFO_Full_St**bit:** 14 **type:** Read **in:** AI_Status_1_Register **address:** 2

This bit reflects the state of the AIFFF pin (after the polarity selection), which indicates the AI data FIFO status:

- 0: Not full.
- 1: Full.

Related bitfields: AI_FIFO_Flags_Polarity.

AI_FIFO_Half_Full_St**bit:** 13 **type:** Read **in:** AI_Status_1_Register **address:** 2

This bit reflects the state of the AIFHF pin (after the polarity selection), which indicates the AI data FIFO status:

- 0: Half-full or less.
- 1: More than half-full.

Related bitfields: AI_FIFO_Flags_Polarity.

AI_FIFO_Interrupt_Enable**bit:** 7 **type:** Write **in:** Interrupt_A_Enable_Register **address:** 73

This bit enables the FIFO interrupt:

- 0: Disabled.
- 1: Enabled.

The FIFO interrupt is generated on the FIFO condition indicated by AI_FIFO_Mode. Related bitfields: AI_FIFO_Mode.

AI_FIFO_Mode**bits:** <6..7> **type:** Write **in:** AI_Mode_3_Register **address:** 87

This bit selects the AI data FIFO condition on which to generate the DMA request (output signal AIFREQ) and the FIFO interrupt (if the FIFO interrupt is enabled):

- 0: Generate DMA request and FIFO interrupt on FIFO not empty. Keep the request and interrupt asserted while the FIFO is not empty.
- 1: Generate DMA request and FIFO interrupt on FIFO more than half-full. Keep the request and interrupt asserted while the FIFO is half-full.
- 2: Generate DMA request and FIFO interrupt on FIFO full. Keep the request and interrupt asserted while the FIFO is full.
- 3: Generate DMA request and FIFO interrupt on FIFO more than half-full. Keep the request and interrupt asserted while the FIFO is not empty.

Selection 3 will cause the request and FIFO interrupt to assert at the end of the acquisition and remain asserted until the FIFO empties, provided that SHIFTIN arrives after the trailing edge of the last SC_TC. The SHIFTIN signal may arrive before the trailing edge of the last SC_TC if an internal CONVERT is used and the SI2 clock is slow with respect to the ADC interval. In this case, you should use the SC_TC interrupt to initiate the final FIFO read at the end of the acquisition. Related bitfields: AI_FIFO_Interrupt_Enable, AI_FIFO_Second_Irq_Enable.

AI_FIFO_Request_St**bit:** 1 **type:** Read **in:** AI_Status_1_Register **address:** 2

This bit indicates the status of the DMA request (output pin AIFREQ) and the FIFO interrupt:

- 0: Not asserted.
- 1: Asserted.

AI_FIFO_Mode selects the condition on which to generate the DMA request and FIFO interrupt. Related bitfields: AI_FIFO_Mode.

AI_FIFO_Second_Irq_Enable

bit: 7 **type:** Write **in:** Second_Irq_A_Enable_Register **address:** 74

This bit enables the FIFO interrupt in the secondary interrupt bank:

- 0: Disabled.
- 1: Enabled.

The FIFO interrupt is generated on the FIFO condition indicated by AI_FIFO_Mode. Related bitfields: AI_FIFO_Mode.

AI_Last_Shiftin_St

bit: 15 **type:** Read **in:** Joint_Status_1_Register **address:** 27

This bit indicates that the last SHIFTIN of the acquisition has occurred. The bit is set on the SHIFTIN following the SC_TC trailing edge. It is cleared by setting AI_SC_TC_Interrupt_Ack to 1. Related bitfields: AI_SC_TC_Interrupt_Ack.



Note *If the SC_CLK is slow with respect to the conversion period, the trailing edge of SC_TC may miss the SHIFTIN pulse. This can happen in the internal CONVERT mode if you select IN_TIMEBASE2 as the SI2 source. For this reason, you must not rely on this bit as an end of acquisition indicator.*

AI_LOCALMUX_CLK_Output_Select

bits: <4..5> **type:** Write **in:** AI_Output_Control_Register **address:** 60

The bitfield enables and selects the polarity of the LOCALMUX_CLK output signal:

- 0: High Z.
- 1: Ground.
- 2: Enable, active low.
- 3: Enable, active high.

AI_LOCALMUX_CLK_Pulse

bit: 2 **type:** Strobe **in:** AI_Command_1_Register **address:** 8

Setting this bit to 1 produces a pulse on the LOCALMUX_CLK output signal, if the output is enabled. The pulsewidth of the output signal is determined by AI_LOCALMUX_CLK_Pulse_Width. LOCALMUX_CLK must also be cleared by an SOC. This bit is cleared automatically. Related bitfields: AI_LOCALMUX_CLK_Output_Select, AI_LOCALMUX_CLK_Pulse_Width

AI_LOCALMUX_CLK_Pulse_Width

bit: 5 **type:** Write **in:** AI_Personal_Register **address:** 77

This bit selects the pulsewidth of the LOCALMUX_FFRT output signal and the minimum pulsewidth of the LOCALMUX_CLK output signal:

- 0: LOCALMUX_FFRT is 0.5–1 AI_OUT_TIMEBASE periods and

LOCALMUX_CLK is 1.5–2 AI_OUT_TIMEBASE periods.

- 1: LOCALMUX_FFRT is 0.5 AI_OUT_TIMEBASE periods and LOCALMUX_CLK is 0.5–1 AI_OUT_TIMEBASE periods.

LOCALMUX_CLK must also be cleared by an SOC.

AI_Output_Divide_By_2

bit: 7 **type:** Write **in:** Clock_and_FOUT_Register **address:** 56

This bit determines the frequency of the internal timebase AI_OUT_TIMEBASE.

- 0: Same as IN_TIMEBASE.
1: IN_TIMEBASE divided by two.

AI_Overflow_St

bit: 10 **type:** Read **in:** AI_Status_1_Register **address:** 2

This bit indicates the detection of an ADC overflow error:

- 0: No error.
1: Error.

The overflow error indicates that an attempt was made to write the ADC result to a full AI data FIFO; that is, the reading from the FIFO is too slow to match the writing to the FIFO. If the overflow error occurs, at least one point of data has been lost. This bit is cleared by setting AI_Error_Interrupt_Ack to 1.

AI_Overrun_Mode

bit: 7 **type:** Write **in:** AI_Personal_Register **address:** 77

This bit selects the period during which new CONVERT pulses are not allowed:

- 0: From SOC to EOC.
1: From SOC to the trailing edge of SHIFTIN.

If a CONVERT pulse occurs within the selected interval, an overrun error is detected (AI_Overrun_St bit is set to 1).

Related bitfields: AI_Overrun_St.

AI_Overrun_St

bit: 11 **type:** Read **in:** AI_Status_1_Register **address:** 2

This bit indicates the detection of an ADC overrun error:

- 0: No error.
1: Error.

The overrun error indicates that the ADC interval is not long enough to complete a conversion. This bit can be cleared by setting AI_Error_Interrupt_Ack to 1. Related bitfields: AI_Overrun_Mode, AI_Error_Interrupt_Ack.

AI_Pre_Trigger

bit: 13 **type:** Write **in:** AI_Mode_2_Register **address:** 13

If AI_Continuous is 0, this bit selects between the posttrigger acquisition mode and the pretrigger acquisition mode:

- 0: Posttrigger acquisition mode.
- 1: Pretrigger acquisition mode.

If AI_Continuous is 1, this bit is not used. Refer to section [2.4.3, Acquisition-Level Timing and Control](#), for more information on the acquisition modes. Related bitfields: AI_Continuous.

AI_Reset

bit: 0 **type:** Strobe **in:** Joint_Reset_Register **address:** 72

Setting this bit to 1 resets all the resettable registers to their power-on state. The resettable registers are:

- AI_Command_1_Register
- AI_Command_2_Register
- AI_Mode_1_Register
- AI_Mode_2_Register
- AI_Mode_3_Register
- AI_Output_Control_Register
- AI_Personal_Register
- AI_START_STOP_Select_Register
- AI_Trigger_Select_Register

Setting this bit to 1 also clears all the status bits and interrupts related to AI, except those associated with the AI data FIFO. This bit is cleared automatically.

AI_Scan_In_Progress_St

bit: 7 **type:** Read **in:** Joint_Status_2_Register **address:** 29

This bit indicates whether a scan is currently in progress. The bit is set when a valid START is received and the bit is cleared when a valid STOP is received.

AI_SCAN_IN_PROG_Output_Select

bits: <8..9> **type:** Write **in:** AI_Output_Control_Register **address:** 60

This bitfield enables and selects the polarity of the SCAN_IN_PROG output signal:

- 0: High Z.
- 1: Ground.
- 2: Enable, active low.
- 3: Enable, active high.

AI_SCAN_IN_PROG_Pulse**bit:** 4 **type:** Write **in:** AI_Command_1_Register **address:** 8

Set this bit to 1 to begin a pulse on the SCAN_IN_PROG output signal, if the output is enabled. Set this bit to 0 to end the pulse. Related bitfields:
AI_SCAN_IN_PROG_Output_Select.

AI_SC_Arm**bit:** 6 **type:** Strobe **in:** AI_Command_1_Register **address:** 8

This bit arms the SC counter. The counter remains armed (and the bit remains set) until it is disarmed, either by hardware or by setting AI_Disarm to 1. Related bitfields:
AI_SC_Arm_St, AI_Disarm.

AI_SC_Armed_St**bit:** 0 **type:** Read **in:** AI_Status_2_Register **address:** 5

This bit indicates whether the SC counter is armed:

- 0: Disarmed.
- 1: Armed.

Related bitfields: AI_SC_Arm.

AI_SC_Gate_Enable**bit:** 15 **type:** Write **in:** AI_Mode_2_Register **address:** 13

This bit enables the SC gate:

- 0: Disabled.
- 1: Enabled.

When the SC gate is enabled, external CONVERT signals pass through the DAQ-STC only when the SC counter is counting or, if in pretriggered mode, waiting for trigger. You must disable the SC gate when internally generated CONVERT pulses are used.

AI_SC_Gate_St**bit:** 4 **type:** Read **in:** Joint_Status_1_Register **address:** 27

This bit indicates the status of the SC gate if the SC gate is enabled.

- 0: SC gate blocks external CONVERTs
- 1: SC gate allows external CONVERTs to pass

Related bitfields: AI_SC_Gate_Enable.

AI_SC_Initial_Load_Source

bit: 2 **type:** Write **in:** AI_Mode_2_Register **address:** 13

If the SC counter is disarmed, this bit selects the initial SC load register:

- 0: Load register A.
- 1: Load register B.

If the SC counter is armed, this bit has no effect. Related bitfields: AI_SC_Arm.

AI_SC_Load

bit: 5 **type:** Strobe **in:** AI_Command_1_Register **address:** 8

If the SC counter is disarmed, this bit loads the SC counter with the contents of the selected SC load register (A or B). If the SC counter is armed, writing to this bit has no effect. This bit is cleared automatically. Related bitfields: AI_SC_Initial_Load_Source.

AI_SC_Load_A

bits: <0..7> **type:** Write **in:** AI_SC_Load_A_Registers **address:** 18

bits: <0..15> **type:** Write **in:** AI_SC_Load_A_Registers **address:** 19

This bitfield is load register A for the SC counter. If load register A is the selected SC load register, the SC counter loads the value contained in this bitfield on AI_SC_Load and on SC_TC. The eight MSBs are located at the lower address and the 16 LSBs are located at the higher address. Related Bitfields: AI_SC_Next_Load_Source_St, AI_SC_Load.

AI_SC_Load_B

bits: <0..7> **type:** Write **in:** AI_SC_Load_B_Registers **address:** 20

bits: <0..15> **type:** Write **in:** AI_SC_Load_B_Registers **address:** 21

This bitfield is load register B for the SC counter. If load register B is the selected SC load register, the SC counter loads the value contained in this bitfield on AI_SC_Load and on SC_TC. The eight MSBs are located at the lower address and the 16 LSBs are located at the higher address. Related Bitfields: AI_SC_Next_Load_Source_St, AI_SC_Load.

AI_SC_Next_Load_Source_St

bit: 1 **type:** Read **in:** AI_Status_2_Register **address:** 5

This bit indicates the next load source of the SC counter:

- 0: Load register A.
- 1: Load register B.

AI_SC_Q_St

bits: <3..4> **type:** Read **in:** AI_Status_2_Register **address:** 5

This bitfield reflects the state of the SC control circuit:

- 0: WAIT 1.
- 1: PCNT.
- 2: WAIT 2.
- 3: CNT.

See section 2.8, *Detailed Description*, for more information on the SC control circuit.

AI_SC_Reload_Mode

bit: 1 **type:** Write **in:** AI_Mode_2_Register **address:** 13

This bit selects the reload mode for the SC counter:

- 0: No automatic change of the SC load register.
- 1: The SC counter will switch load registers on every SC_TC.

You can use setting 1 for pretrigger acquisition mode and for staged analog input.

AI_SC_Save_St

bit: 2 **type:** Read **in:** AI_Status_2_Register **address:** 5

This bit indicates the status of the SC save register:

- 0: SC save register is tracing the counter.
- 1: SC save register is latched for later read.

Related bitfields: AI_SC_Save_Trace.

AI_SC_Save_Trace

bit: 10 **type:** Write **in:** AI_Command_2_Register **address:** 4

Setting this bit to 1 causes the SC save register to latch the SC counter value at the next SC_CLK falling edge. Setting this bit to 0 causes the SC save register to trace the SC counter.

AI_SC_Save_Value

bits: <0..7> **type:** Read **in:** AI_SC_Save_Registers **address:** 66

bits: <0..15> **type:** Read **in:** AI_SC_Save_Registers **address:** 67

When AI_SC_Save_Trace is 0, this bitfield reflects the contents of the SC counter. When you set AI_SC_Save_Trace to 1, this bitfield synchronously latches the contents of the SC counter using the SC source. The eight MSBs are located at the lower address and the 16 LSBs are located at the higher address. Related bitfields: AI_SC_Save_Trace.

AI_SC_Switch_Load_On_TC**bit:** 4 **type:** Strobe **in:** AI_Command_2_Register **address:** 4

Setting this bit to 1 causes the SC counter to switch load registers at the next SC_TC. You can use this bit for staged analog input. This bit is cleared automatically.

AI_SC_TC_Error_Confirm**bit:** 7 **type:** Strobe **in:** Interrupt_A_Ack_Register **address:** 2

Setting this bit to 1 clears AI_SC_TC_Error_St. This bit is cleared automatically. Related bitfields: AI_SC_TC_Error_St.

AI_SC_TC_Error_St**bit:** 9 **type:** Read **in:** AI_Status_1_Register **address:** 2

This bit indicates the detection of an SC_TC error:

- 0: No error.
- 1: Error.

An SC_TC error is detected if AI_SC_TC_Interrupt_Ack is not set between two SC TCs. This allows you to detect large interrupt latencies and potential problems associated with them. To clear this bit, set SC_TC_Error_Confirm to 1. Related bitfields: AI_SC_TC_Interrupt_Ack, AI_SC_TC_Error_Confirm.

AI_SC_TC_Interrupt_Ack**bit:** 8 **type:** Strobe **in:** Interrupt_A_Ack_Register **address:** 2

Setting this bit to 1 clears AI_Last_Shiftin_St, AI_SC_TC_St, and the SC_TC interrupt request (in either interrupt bank) if the SC_TC interrupt is enabled. This bit is cleared automatically. Related bitfields: AI_Last_Shiftin_St, AI_SC_TC_St.

AI_SC_TC_Interrupt_Enable**bit:** 0 **type:** Write **in:** Interrupt_A_Enable_Register **address:** 73

This bit enables the SC_TC interrupt:

- 0: Disabled.
- 1: Enabled.

SC_TC interrupts are generated on every SC_TC falling edge unless the pretrigger acquisition mode is selected. In the pretrigger acquisition mode, the first SC_TC falling edge does not generate an interrupt, but subsequent SC_TC falling edges do.

AI_SC_TC_Output_Select**bits:** <2..3> **type:** Write **in:** AI_Output_Control_Register **address:** 60

This bitfield enables and selects polarity for the SC_TC output signal:

- 0: High Z.
- 1: Ground.
- 2: Enable, active low.
- 3: Enable, active high.

AI_SC_TC_Pulse**bit:** 1 **type:** Write **in:** AI_Command_1_Register **address:** 8

Set this bit to 1 to begin a pulse on the SC_TC output signal if the output is enabled. Set this bit to 0 to end the pulse. Related bitfields: AI_SC_TC_Output_Select.

AI_SC_TC_Second_Irq_Enable**bit:** 0 **type:** Write **in:** Second_Irq_A_Enable_Register **address:** 74

This bit enables the SC_TC interrupt in the secondary interrupt bank:

- 0: Disabled.
- 1: Enabled.

SC_TC interrupts are generated on every SC_TC falling edge, unless the pretrigger acquisition mode is selected. In the pretrigger acquisition mode, the first SC_TC falling edge does not generate an interrupt, but subsequent SC_TC falling edges do.

AI_SC_TC_St**bit:** 6 **type:** Read **in:** AI_Status_1_Register **address:** 2

This bit indicates whether the SC counter has reached TC:

- 0: No.
- 1: Yes.

You can clear this bit by setting AI_SC_TC_Interrupt_Ack to 1. Related bitfields: AI_SC_TC_Interrupt_Ack.

Refer to Table 8-2, *Interrupt Condition Summary*, for more information.

AI_SC_Write_Switch**bit:** 0 **type:** Write **in:** AI_Mode_2_Register **address:** 13

This bit enables the write switch feature of the SC load registers. Writes to SC load register A are:

- 0: Unconditionally directed to SC load register A.
- 1: Directed to the inactive SC load register.

AI_SHIFTIN_Polarity**bit:** 12 **type:** Write **in:** AI_Personal_Register **address:** 77

This bit selects the polarity of the AI_FIFO_SHIFTIN output signal:

- 0: Active low.
- 1: Active high.

AI_SHIFTIN_Pulse_Width**bit:** 15 **type:** Write **in:** AI_Personal_Register **address:** 77

This bit determines the pulsewidth of the SHIFTIN and AI_FIFO_SHIFTIN output signals:

- 0: 0.5–1.5 AI_OUT_TIMEBASE periods.
- 1: 1.5–2 AI_OUT_TIMEBASE periods.

The leading edge of the SHIFTIN and AI_FIFO_SHIFTIN pulses occurs immediately after the active edge of EOC.

AI_SI_Arm**bit:** 10 **type:** Strobe **in:** AI_Command_1_Register **address:** 8

Setting this bit to 1 arms the SI counter. The counter remains armed (and the bit remains set) until it is disarmed, either by hardware or by setting AI_Disarm to 1. Related bitfields: AI_SI_Armed_St, AI_Disarm.

AI_SI_Armed_St**bit:** 5 **type:** Read **in:** AI_Status_2_Register **address:** 5

This bit indicates whether the SI counter is armed:

- 0: Disarmed
- 1: Armed

Related bitfields: AI_SI_Arm.

AI_SI_Count_Enabled_St**bit:** 8 **type:** Read **in:** AI_Status_2_Register **address:** 5

If the SI counter is armed, this bit indicates whether the SI counter is enabled to count:

- 0: No.
- 1: Yes.

If the SI counter is disarmed, this bit should be ignored.

AI_SI_Initial_Load_Source

bit: 7 **type:** Write **in:** AI_Mode_2_Register **address:** 13

If the SI counter is disarmed, this bit selects the initial SI load register:

- 0: Load register A.
- 1: Load register B.

If the SI counter is armed, writing to this bit has no effect.

AI_SI_Load

bit: 9 **type:** Strobe **in:** AI_Command_1_Register **address:** 8

If the SI counter is disarmed, this bit loads the SI counter with the contents of the selected SI load register (A or B). If the SI counter is armed, writing to this bit has no effect. This bit is cleared automatically.

AI_SI_Load_A

bits: <0..7> **type:** Write **in:** AI_SI_Load_A_Registers **address:** 14

bits: <0..15> **type:** Write **in:** AI_SI_Load_A_Registers **address:** 15

This bitfield is load register A for the SI counter. If load register A is the selected SI load register, the SI counter loads the value contained in this bitfield on AI_SI_Load and on SI_TC. The eight MSBs are located at the lower address and the 16 LSBs are located at the higher address. Related Bitfields: AI_SI_Next_Load_Source_St, AI_SI_Load.

AI_SI_Load_B

bits: <0..7> **type:** Write **in:** AI_SI_Load_B_Registers **address:** 16

bits: <0..15> **type:** Write **in:** AI_SI_Load_B_Registers **address:** 17

This bitfield is load register B for the SI counter. If load register B is the selected SI load register, the SI counter loads the value contained in this bitfield on AI_SI_Load and on SI_TC. The eight MSBs are located at the lower address and the 16 LSBs are located at the higher address. Related Bitfields: AI_SI_Next_Load_Source_St, AI_SI_Load.

AI_SI_Next_Load_Source_St

bit: 6 **type:** Read **in:** AI_Status_2_Register **address:** 5

This bit indicates the next load source of the SI counter:

- 0: Load register A.
- 1: Load register B.

AI_SI_Q_St

bits: <9..10> **type:** Read **in:** AI_Status_2_Register **address:** 5

This bitfield reflects the state of the SI control circuit:

- 0: WAIT 1.
- 1: CNT 1.

See section 2.8, *Detailed Description*, for more information on the SI control circuit.

AI_SI_Reload_Mode

bits: <4..6> **type:** Write **in:** AI_Mode_2_Register **address:** 13

This bitfield selects the reload mode for the SI counter:

- 0: No automatic change of the SI load register.
- 4: Alternate first period on every STOP. Use this setting to make the time interval between the START trigger and the first sample pulse different from the remaining sample intervals.
- 5: Switch load register on every STOP. Use this setting to synchronously change the sample interval at each STOP.
- 6: Alternate first period on every SC_TC. Use this setting to make the interval between the START1 trigger and the first scan different from the scan interval.
- 7: Switch load register on every SC_TC. Use this setting to synchronously change the scan interval at each SC_TC.

AI_SI_Save_Value

bits: <0..7> **type:** Read **in:** AI_SI_Save_Registers **address:** 64

bits: <0..15> **type:** Read **in:** AI_SI_Save_Registers **address:** 65

This bitfield reflects the contents of the SI counter. Reading from this bitfield while the SI counter is counting may result in an erroneous value. The eight MSBs are located at the lower address and the 16 LSBs are located at the higher address.

AI_SI_Source_Polarity

bit: 4 **type:** Write **in:** AI_Mode_1_Register **address:** 12

This bit selects the active edge of the SI source (the signal that is selected by AI_SI_Source_Select):

- 0: Rising edge.
- 1: Falling edge.

Set this bit to 0 if an internal timebase is used. Related bitfields: AI_SI_Source_Select.

AI_SI_Source_Select**bits:** <6..10> **type:** Write **in:** AI_Mode_1_Register **address:** 12

This bitfield selects the SI source:

- 0: AI_IN_TIMEBASE1.
- 1–10: PFI<0..9>.
- 11–17: RTSI_TRIGGER<0..6>.
- 19: IN_TIMEBASE2.
- 31: Logic low.

Related bitfields: AI_SI_Source_Polarity, AI_SI2_Source_Select.

AI_SI_Special_Trigger_Delay**bit:** 12 **type:** Write **in:** AI_Mode_3_Register **address:** 87

Setting this bit to 1 in the external START mode causes the SI counter to block START pulses for a fixed time period after the START1 trigger. This feature allows you to have an extra timing parameter in the scan timing when you use an external START. Refer to section [2.4.2, Scan-Level Timing and Control](#), for more information on the SI Special Trigger Delay. Notice that the time period may be expressed as the number of START pulses blocked. Do not set this bit to 1 in the internal START mode.

AI_SI_Switch_Load_On_SC_TC**bit:** 9 **type:** Strobe **in:** AI_Command_2_Register **address:** 4

Setting this bit to 1 causes the SI counter to switch load registers at the next SC_TC. This action is internally synchronized to the falling edge of the internal signal SI_CLK. You can use this bit for scan rate change during an acquisition and for staged analog input. This bit is cleared automatically.

AI_SI_Switch_Load_On_STOP**bit:** 8 **type:** Strobe **in:** AI_Command_2_Register **address:** 4

Setting this bit to 1 causes the SI counter to switch load registers upon receiving a STOP trigger. This action is internally synchronized to the falling edge of the internal signal SI_CLK. This bit is cleared automatically.

AI_SI_Switch_Load_On_TC**bit:** 7 **type:** Strobe **in:** AI_Command_2_Register **address:** 4

Setting this bit to 1 causes the SI counter to switch load registers at its next TC. This action is internally synchronized to the falling edge of the internal signal SI_CLK. You can use this bit for scan rate change during an acquisition. This bit is cleared automatically.

AI_SI_Write_Switch**bit:** 3 **type:** Write **in:** AI_Mode_2_Register **address:** 13

This bit enables the write switch feature of the SI load registers. Writes to SI load register A are:

- 0: Unconditionally directed to SI load register A.
- 1: Directed to the inactive SI load register.

AI_SI2_Arm**bit:** 12 **type:** Strobe **in:** AI_Command_1_Register **address:** 8

Setting this bit to 1 arms the SI2 counter. The counter remains armed and the bit remains set until it is disarmed, either by hardware or by setting AI_Disarm to 1. Related bitfields: AI_SI2_Armed_St, AI_Disarm.

AI_SI2_Armed_St**bit:** 11 **type:** Read **in:** AI_Status_2_Register **address:** 5

This bit indicates whether the SI2 counter is armed:

- 0: Disarmed.
- 1: Armed.

Related bitfields: AI_SI2_Arm.

AI_SI2_Initial_Load_Source**bit:** 9 **type:** Write **in:** AI_Mode_2_Register **address:** 13

This bit selects the initial SI2 load register:

- 0: Load register A.
- 1: Load register B.

Do not change this bit while the counter is counting.

AI_SI2_Load**bit:** 11 **type:** Strobe **in:** AI_Command_1_Register **address:** 8

If the SI2 counter is disarmed, this bit loads the SI2 counter with the contents of the selected SI2 load register (A or B). If the SI2 counter is armed, writing to this bit has no effect. This bit is cleared automatically.

AI_SI2_Load_A**bits:** <0..15> **type:** Write **in:** AI_SI2_Load_A_Register **address:** 23

This bitfield is load register A for the SI2 counter. If load register A is the selected SI2 load register, the SI2 counter loads the value contained in this bitfield on AI_SI2_Load and on SI2_TC. Related Bitfields: AI_SI2_Next_Load_Source_St, AI_SI2_Load.

AI_SI2_Load_B

bits: <0..15> **type:** Write **in:** AI_SI2_Load_B_Register **address:** 25

This bitfield is load register B for the SI2 counter. If load register B is the selected SI2 load register, the SI2 counter loads the value contained in this bitfield on AI_SI2_Load and on SI2_TC. Related Bitfields: AI_SI2_Next_Load_Source_St, AI_SI2_Load.

AI_SI2_Next_Load_Source_St

bit: 12 **type:** Read **in:** AI_Status_2_Register **address:** 5

This bit indicates the next load source of the SI2 counter:

- 0: Load register A.
- 1: Load register B.

AI_SI2_Q_St

bits: <8..9> **type:** Read **in:** Joint_Status_1_Register **address:** 27

This bitfield reflects the state of the SI2 control circuit:

- 0: WAIT 1.
- 1: CNT.
- 2: WAIT 2.

See section 2.8, *Detailed Description*, for more information on the SI2 control circuit.

AI_SI2_Reload_Mode

bit: 8 **type:** Write **in:** AI_Mode_2_Register **address:** 13

This bit selects the reload mode for the SI2 counter:

- 0: No automatic change of the SI2 load register.
- 1: Alternate first period on every STOP.

Set this bit to 1 in the internal CONVERT mode to make the time interval between the START trigger and the first CONVERT different from the time interval between CONVERTs.

AI_SI2_Save_Value

bits: <0..15> **type:** Read **in:** AI_SI2_Save_Register **address:** 25

This bitfield reflects the contents of the SI2 counter. Reading from this bitfield while the SI2 counter is counting may result in an erroneous value.

AI_SI2_Source_Select

bit: 11 **type:** Write **in:** AI_Mode_3_Register **address:** 87

This bit selects the SI2 source:

- 0: The same signal selected as the SI source. Refer to AI_SI_Source_Select.
- 1: AI_IN_TIMEBASE1.

Related bitfields: AI_SI_Source_Select.

AI_SOC_Polarity

bit: 13 **type:** Write **in:** AI_Personal_Register **address:** 77

This bit determines which edge of the SOC input signal indicates start of conversion:

- 0: Rising edge.
- 1: Falling edge.

Related bitfields: AI_SOC_St.

AI_SOC_St

bit: 3 **type:** Read **in:** Joint_Status_2_Register **address:** 29

This bit reflects the state of the SOC pin (after the polarity selection). This bit is useful for device diagnostic applications. Related bitfields: AI_SOC_Polarity.

AI_Software_Gate

bit: 13 **type:** Write **in:** AI_Mode_3_Register **address:** 87

This bit controls the software gate, which you can use to pause an analog input operation:

- 0: Enable operation.
- 1: Pause operation.

Refer to section 2.4.4, *Gating*, for more information on software gating. Note that the hardware gate must be enabled in order for the software gate to operate properly. Related bitfields: AI_External_Gate_Mode.

AI_Source_Divide_By_2

bit: 6 **type:** Write **in:** Clock_and_FOUT_Register **address:** 56

This bit determines the frequency of the internal timebase AI_IN_TIMEBASE1:

- 0: Same as IN_TIMEBASE.
- 1: IN_TIMEBASE divided by two.

AI_START_Edge**bit:** 5 **type:** Write **in:** AI_START_STOP_Select_Register **address:** 62

This bit enables edge detection of the START trigger:

- 0: Disabled (level-sensitive trigger).
- 1: Enabled (edge-sensitive trigger).

This bit should normally be set to 1.

AI_START_Interrupt_Ack**bit:** 11 **type:** Strobe **in:** Interrupt_A_Ack_Register **address:** 2

Setting this bit to 1 clears AI_START_St and acknowledges the START interrupt request (in either interrupt bank) if the START interrupt is enabled. This bit is cleared automatically.

Related bitfields: AI_START_St.

AI_START_Interrupt_Enable**bit:** 3 **type:** Write **in:** Interrupt_A_Enable_Register **address:** 73

This bit enables the START interrupt:

- 0: Disabled.
- 1: Enabled.

The START interrupt is generated on valid START triggers received by the DAQ-STC. A valid START trigger is one that is received while the SC counter is enabled to count.

AI_START_Output_Select**bit:** 10 **type:** Write **in:** AI_Output_Control_Register **address:** 60

This bit selects the output source for the bidirectional pin PFI7/AI_START_Pulse if the pin is configured for output:

- 0: If AI_Trigger_Length is set to 0, the pin will reflect the internal signal AD_START. If AI_Trigger_Length is set to 1, the pin will reflect the internal signal AD_START after it has been pulse stretched to be 1–2 AI_OUT_TIMEBASE periods long.
- 1: The pin will output the same signal as SCAN_IN_PROG. If SCAN_IN_PROG is configured for high impedance, the pin will output ground.

Related bitfields: BD_7_Pin_Dir, AI_Trigger_Length.

AI_START_Polarity**bit:** 15 **type:** Write **in:** AI_START_STOP_Select_Register **address:** 62

This bit determines the polarity of START trigger:

- 0: Active high or rising edge.
- 1: Active low or falling edge.

AI_START_Pulse

bit: 2 **type:** Strobe **in:** AI_Command_2_Register **address:** 4

Setting this bit to 1 sends a START trigger to the counters if the START software strobe is selected (AI_START_Select is set to 18). This bit is cleared automatically. Related bitfields: AI_START_Select.

AI_START_Second_Irq_Enable

bit: 3 **type:** Write **in:** Second_Irq_A_Enable_Register **address:** 74

This bit enables the START interrupt in the secondary interrupt bank:

- 0: Disabled.
- 1: Enabled.

The START interrupt is generated on valid START triggers received by the DAQ-STC. A valid START trigger is one that is received while the SC counter is enabled to count.

AI_START_Select

bits: <0..4> **type:** Write **in:** AI_START_STOP_Select_Register **address:** 62

This bit selects the START trigger:

- 0: The internal signal SI_TC.
- 1–10: PFI<0..9>.
- 11–17: RTSI_TRIGGER<0..6>.
- 18: Bitfield AI_START_Pulse.
- 19: The internal signal G_OUT from general-purpose counter 0.
- 31: Logic low.

When you set this bit to 0, the DAQ-STC is in the internal START mode. When you select any other signal as the START trigger, the DAQ-STC is in the external START mode. Related bitfields: AI_START_Pulse.

AI_START_St

bit: 5 **type:** Read **in:** AI_Status_1_Register **address:** 2

This bit indicates that a valid START trigger has been received by the AITM:

- 0: No.
- 1: Yes.

A valid START trigger is one that is received while the SC counter is enabled to count. You can clear this bit by setting AI_START_Interrupt_Ack to 1. Refer to Table 8-2, [Interrupt Condition Summary](#), for more information.

AI_Start_Stop

bit: 3 **type:** Write **in:** AI_Mode_1_Register **address:** 12

This bit enables START and STOP control of the analog input operation:

- 0: Disabled.
- 1: Enabled.

You should normally set this bit to 1.

AI_Start_Stop_Gate_Enable

bit: 14 **type:** Write **in:** AI_Mode_2_Register **address:** 13

This bit enables the start/stop gate (STST_GATE):

- 0: Disabled.
- 1: Enabled.

When start/stop gate is enabled, external CONVERT pulses pass through the DAQ-STC only during the interval between the assertion of START and the assertion of STOP. You should enable the start/stop gate in the external CONVERT mode. You must disable the start/stop gate in the internal CONVERT mode. Related bitfields: AI_Start_Stop_Gate_St.

AI_Start_Stop_Gate_St

bit: 5 **type:** Read **in:** Joint_Status_1_Register **address:** 27

This bit indicates the status of the start/stop gate, if start/stop gating is enabled:

- 0: External CONVERTs are blocked because a valid START has not been received.
- 1: External CONVERTs are allowed to pass.

Related bitfields: AI_Start_Stop_Gate_Enable.

AI_START_Sync

bit: 6 **type:** Write **in:** AI_START_STOP_Select_Register **address:** 62

This bit enables internal synchronization of the START trigger:

- 0: Disabled.
- 1: Enabled.

You should normally set this bit to 1. You must set this bit to 0 for the single-wire case.

AI_START1_Disable

bit: 11 **type:** Write **in:** AI_Command_2_Register **address:** 4

This bit disables recognition of the START1 trigger:

- 0: Enabled.
- 1: Disabled.

Use this bit if you want the same START1 trigger to start several activities. First, disable START1 by setting this bit to 1, do the necessary programming on all DAQ-STCs, and then enable START1 by setting this bit to 0.

AI_START1_Edge**bit:** 5 **type:** Write **in:** AI_Trigger_Select_Register **address:** 63

This bit enables edge detection of the START1 trigger:

- 0: Disabled (level-sensitive trigger).
- 1: Enabled (edge-sensitive trigger).

You should normally set this bit to 1. You must set this bit to 1 if AI_START1_Select is set to 0. You should set this bit to 0 if the ASIC is a START1 slave to another DAQ-STC.

AI_START1_Interrupt_Ack**bit:** 9 **type:** Strobe **in:** Interrupt_A_Ack_Register **address:** 2

Setting this bit to 1 clears AI_START1_St and acknowledges the START1 interrupt request (in either interrupt bank) if the START1 interrupt is enabled. This bit is cleared automatically. Related bitfields: AI_START1_St.

AI_START1_Interrupt_Enable**bit:** 1 **type:** Write **in:** Interrupt_A_Enable_Register **address:** 73

This bit enables the START1 interrupt:

- 0: Disabled.
- 1: Enabled.

The START1 interrupt is generated on valid START1 triggers received by the DAQ-STC. A valid START1 trigger is one that is received while the SC counter is armed and in the WAIT1 state.

AI_START1_Polarity**bit:** 15 **type:** Write **in:** AI_Trigger_Select_Register **address:** 63

This bit determines the polarity of the START1 trigger:

- 0: Active high or rising edge.
- 1: Active low or falling edge.

You should set this bit to 0 if AI_START1_Select is set to 0. Related bitfields: AI_START1_Select.

AI_START1_Pulse**bit:** 0 **type:** Strobe **in:** AI_Command_2_Register **address:** 4

Setting this bit to 1 sends a START1 trigger to the counters if the START1 software strobe is selected (AI_START1_Select is set to 0). This bit is cleared automatically. Related bitfields: AI_START1_Select.

AI_START1_Second_Irq_Enable

bit: 1 **type:** Write **in:** Second_Irq_A_Enable_Register **address:** 74

This bit enables the START1 interrupt in the secondary interrupt bank:

- 0: Disabled.
- 1: Enabled.

The START1 interrupt is generated on valid START1 triggers received by the DAQ-STC. A valid START1 trigger is one that is received while the SC counter is armed and in the WAIT1 state.

AI_START1_Select

bits: <0..4> **type:** Write **in:** AI_Trigger_Select_Register **address:** 63

This bitfield selects the START1 trigger:

- 0: Bitfield AI_START1_Pulse.
- 1–10: PFI<0..9>.
- 11–17: RTSI_TRIGGER<0..6>.
- 18: The internal signal G_OUT from general-purpose counter 0.
- 31: Logic low.

Related bitfields: AI_START1_Pulse.

AI_START1_St

bit: 7 **type:** Read **in:** AI_Status_1_Register **address:** 2

This bit indicates that a valid START1 trigger has been received by the DAQ-STC:

- 0: No.
- 1: Yes.

A valid START1 trigger is one that is received while the SC counter is armed and in the WAIT1 state.

This bit can be cleared by setting AI_START1_Interrupt_Ack to 1. Related bitfields: AI_SC_Arm, AI_START1_Interrupt_Ack. Refer to Table 8-2, [Interrupt Condition Summary](#), for more information.

AI_START1_Sync

bit: 6 **type:** Write **in:** AI_Trigger_Select_Register **address:** 63

This bit enables internal synchronization of the START1 trigger to the SC source:

- 0: Disabled.
- 1: Enabled.

You should set this bit to 1 unless START1 is synchronized externally (to the signal selected as the CONVERT source). You must set this bit to 1 if AI_START1_Select is set to 0. You should set this bit to 0 if the ASIC is a START1 slave to another DAQ-STC. Related bitfields: AI_START1_Select.

AI_START2_Edge

bit: 12 **type:** Write **in:** AI_Trigger_Select_Register **address:** 63

This bit enables edge detection of the START2 trigger:

- 0: Disabled.
- 1: Enabled.

You should normally set this bit to 1 unless the DAQ-STC is used in a very noisy environment. You should set this bit to 0 if the ASIC is a START2 slave to another DAQ-STC.

AI_START2_Interrupt_Ack

bit: 10 **type:** Strobe **in:** Interrupt_A_Ack_Register **address:** 2

Setting this bit to 1 clears AI_START2_St and acknowledges the START2 interrupt request (in either interrupt bank) if the START2 interrupt is enabled. This bit is cleared automatically.

Related bitfields: AI_START2_St, AI_START2_Interrupt_Enable.

AI_START2_Interrupt_Enable

bit: 2 **type:** Write **in:** Interrupt_A_Enable_Register **address:** 73

This bit enables the START2 interrupt:

- 0: Disabled.
- 1: Enabled.

The START2 interrupt is generated on valid START2 triggers received by the DAQ-STC. A valid START2 trigger is one that is received while the SC counter is in the WAIT2 state.

AI_START2_Polarity

bit: 14 **type:** Write **in:** AI_Trigger_Select_Register **address:** 63

This bit determines the polarity of START2 trigger:

- 0: Active high or rising edge.
- 1: Active low or falling edge.

You should set this bit to 0 if AI_START2_Select is set to 0. Related bitfields: AI_START2_Select.

AI_START2_Pulse

bit: 1 **type:** Strobe **in:** AI_Command_2_Register **address:** 4

Setting this bit to 1 sends a START2 trigger to the SC counter if the START2 software strobe is selected (AI_START2_Select is set to 0). This bit is cleared automatically. Related bitfields: AI_START2_Select.

AI_START2_Second_Irq_Enable**bit:** 2 **type:** Write **in:** Second_Irq_A_Enable_Register **address:** 74

This bit enables the START2 interrupt in the secondary interrupt bank:

- 0: Disabled.
- 1: Enabled.

The START2 interrupt is generated only on valid START2 triggers received by the DAQ-STC. A valid START2 trigger is one that is received while the SC counter is in the WAIT2 state.

AI_START2_Select**bits:** <7..11> **type:** Write **in:** AI_Trigger_Select_Register **address:** 63

This bitfield selects the START2 trigger:

- 0: Bitfield AI_START2_Pulse.
- 1–10: PFI<0..9>.
- 11–17: RTSI_TRIGGER<0..6>.
- 31: Logic low.

Related bitfields: AI_START2_Pulse.

AI_START2_St**bit:** 8 **type:** Read **in:** AI_Status_1_Register **address:** 2

This bit indicates whether a valid START2 trigger has been received by the SC counter in the pretrigger acquisition mode:

- 0: No.
- 1: Yes.

A valid START2 signal is one that is received while the SC counter is in the WAIT2 state. You can clear this bit by setting AI_START2_Interrupt_Ack to 1. Refer to Table 8-2, [Interrupt Condition Summary](#), for more information.

AI_START2_Sync**bit:** 13 **type:** Write **in:** AI_Trigger_Select_Register **address:** 63

This bit enables internal synchronization of the START2 trigger to the SC source:

- 0: Disabled.
- 1: Enabled.

You should set this bit to 1 unless START2 is synchronized externally (to the signal that is selected as the CONVERT source). You must set this bit to 1 if AI_START2_Select is set to 0. You should set this bit to 0 if the ASIC is a START2 slave to another DAQ-STC. Related bitfields: AI_START2_Select.

AI_STOP_Edge

bit: 12 **type:** Write **in:** AI_START_STOP_Select_Register **address:** 62

This bit enables edge detection of the STOP trigger:

- 0: Disabled (level-sensitive trigger).
- 1: Enabled (edge-sensitive trigger).

You should set this bit to 0 if AI_STOP_Select is set to 31, or if you want single-channel operation. You should set this bit to 1 if AI_STOP_Select is set to 0. Related bitfields: AI_STOP_Select.

AI_STOP_Interrupt_Ack

bit: 12 **type:** Strobe **in:** Interrupt_A_Ack_Register **address:** 2

Setting this bit to 1 clears AI_STOP_St and acknowledges the STOP interrupt request (in either interrupt bank) if the STOP interrupt is enabled. This bit is cleared automatically. Related bitfields: AI_STOP_St.

AI_STOP_Interrupt_Enable

bit: 4 **type:** Write **in:** Interrupt_A_Enable_Register **address:** 73

This bit enables the STOP interrupt:

- 0: Disabled.
- 1: Enabled.

The STOP interrupt is generated on valid STOP triggers recognized by the DAQ-STC. A valid STOP trigger is one that is received while the SC counter is enabled to count yet after a valid START.



Caution *You must use the STOP interrupt in conjunction with the START interrupt; otherwise, the STOP interrupt does not execute.*

AI_STOP_Polarity

bit: 14 **type:** Write **in:** AI_START_STOP_Select_Register **address:** 62

This bit determines the polarity of STOP trigger:

- 0: Active high or rising edge.
- 1: Active low or falling edge.

Set this bit to 0 if AI_STOP_Select is set to 0. You should set this bit to 1 if AI_STOP_Select is set to 31.

AI_STOP_Pulse

bit: 3 **type:** Strobe **in:** AI_Command_2_Register **address:** 4

Setting this bit to 1 sends a STOP trigger to the counters if the STOP software strobe is selected (AI_STOP_Select is set to 0). This bit is cleared automatically. Related bitfields: AI_STOP_Select.

AI_STOP_Second_Irq_Enable**bit:** 4 **type:** Write **in:** Second_Irq_A_Enable_Register **address:** 74

This bit enables the STOP interrupt in the secondary interrupt bank:

- 0: Disabled.
- 1: Enabled.

The STOP interrupt is generated on valid STOP triggers recognized by the DAQ-STC. A valid STOP trigger is one that is received while the SC counter is enabled to count yet after a valid START.



Caution *You must use the STOP interrupt in conjunction with the START interrupt; otherwise, the STOP interrupt does not execute.*

AI_STOP_Select**bits:** <7..11> **type:** Write **in:** AI_START_STOP_Select_Register **address:** 62

This bitfield selects the STOP trigger:

- 0: The internal signal DIV_TC or bitfield AI_STOP_Pulse.
- 1–10: PFI<0..9>.
- 11–17: RTSI_TRIGGER<0..6>.
- 18: The internal signal SI2_TC.
- 19: Signal present on the AI_STOP_IN pin.
- 31: Logic low.

Set this bit to 31 for single-channel operation if your board does not have configuration memory. Related bitfields: AI_STOP_Pulse.

AI_STOP_St**bit:** 4 **type:** Read **in:** AI_Status_1_Register **address:** 2

This bit indicates that a valid STOP signal has been received by the AITM:

- 0: No.
- 1: Yes.

A valid STOP trigger is one that is received while the SC counter is enabled to count yet after a valid START. This bit is cleared by setting AI_STOP_Interrupt_Ack to 1. Related bitfields: AI_STOP_Interrupt_Ack. Refer to Table 8-2, *Interrupt Condition Summary*, for more information.

AI_STOP_Sync

bit: 13 **type:** Write **in:** AI_START_STOP_Select_Register **address:** 62

This bit enables internal synchronization of the STOP trigger to the internal signal FSC_SRC:
0: Disabled.
1: Enabled.

You should set this bit to 0 if the STOP is generated by a configuration memory on your board. Otherwise, you should set this bit to 1 (unless you can guarantee synchronization by some other means). You must set this bit to 1 if AI_STOP_Select is set to 0. Related bitfields: AI_STOP_Sync.

AI_Trigger_Length

bit: 15 **type:** Write **in:** AI_Mode_3_Register **address:** 87

This bit determines the length of the signals appearing on the bidirectional pins PFI0/AI_START1 and PFI1/AI_START2 when the pins are configured for output. It also determines the length of the signal appearing on the bidirectional pin PFI7/AI_START when the pin is configured to output the internal signal AD_START:

- 0: Output the normal internal version of the signal.
- 1: Pulse stretch the internal signal to be 1–2 AI_OUT_TIMEBASE periods long.

Use the bitfield AI_START_Output_Select to select the signal appearing on the pin PFI/AI_START. Refer to section 5.3, Pin Interface, for a description of the internal signal appearing on each bidirectional PFI pin.

Related bitfields: AI_START_Output_Select.

AI_Trigger_Once

bit: 0 **type:** Write **in:** AI_Mode_1_Register **address:** 12

This bit controls the retriggerability of the SC, SI, SI2, and DIV counters:

- 0: The counters remain armed and retriggerable after generating a timing sequence.
- 1: The counters are disarmed after one analog input timing sequence.

Set this bit to 1 only if AI_Continuous is set to 0. Set this bit to 0 for a single-finite-pretrigger-infinite-posttrigger analog input operation. Related bitfields: AI_Continuous.



Note *If the operation is halted by AI_End_On_End_Of_Scan or AI_End_On_SC_TC, the counters are disarmed regardless of the state of this bit.*

2.7 Timing Diagrams

The DAQ-STC is primarily a synchronous device and requires careful inspection of the timing parameters when you are designing a new board. Related subsections within the chip can be programmed to operate at different clock rates, and the necessary synchronization time can significantly affect the edges and pulsewidths of the board-level signals. Certain configurations of the clock rates offer very straightforward timing signals, and these settings should be used for the majority of the DAQ-STC designs. The other modes are included to provide flexibility for unusual or currently unanticipated applications.

This section includes all of the timing diagrams for the AITM module of the DAQ-STC and indicates the more common configurations.

2.7.1 Signal Definitions

All timing in this section refers to pin-to-pin timing. Because many of the timing parameter definitions are based on internal signals and the internal signals can be selected from a variety of sources, this section defines some global signals that can refer to any one of a number of pins depending on the internal selection.

Some of the tables in this section indicate that the OSC pin is the reference pin, with RTSI_OSC immediately following. This means that you can use RTSI_Clock_Mode to choose between OSC and RTSI_OSC as the reference pin.

2.7.1.1 CONVERT_SRC

CONVERT_SRC is the signal that causes a CONVERT to be generated. Table 2-2 indicates the pin selected as CONVERT_SRC based on internal selection.

Table 2-2. CONVERT_SRC Reference Pin Selection

AI_CONVERT_Source_Select	Reference Pin
0	The CONVERT source is selected to be SI2_TC inverted. The reference pin is determined by AI_SI2_Source_Select. If AI_SI2_Source_Select is 0, the reference pin is determined by AI_SI_Source_Select. If AI_SI2_Source_Select is 1, the reference pin is OSC or RTSI_OSC, depending on which clock mode you choose in RTSI_Clock_Mode.
1–10	PFI<0..9>

Table 2-2. CONVERT_SRC Reference Pin Selection (Continued)

AI_CONVERT_Source_Select	Reference Pin
11–17	RTSI_TRIGGER<0..6>
19	The CONVERT source is selected to be the output of general-purpose counter 0. The reference pin is determined by the G0_Source_Select bitfield. To determine delays for this case, add the source to output delay (Tso) from general-purpose counter 0.

2.7.1.2 OUT_CLK

OUT_CLK is the AI_OUT_TIMEBASE signal, which can come from the OSC input or the RTSI_OSC input, respectively, depending on which clock mode you choose in RTSI_Clock_Mode. If the output clock is set for divide-by-two operation, each edge of OUT_CLK represents a rising edge of OSC (or RTSI_OSC). Otherwise, OUT_CLK and OSC (or RTSI_OSC) are identical.

2.7.2 Basic Analog Input Timing

The basic analog input functionality provided by the DAQ-STC is to time conversions and load the resulting data into a FIFO. The primary output signals are CONVERT and SHIFTIN, and the input signals are SOC and EOC. The timing for these signals is shown in Figure 2-16.

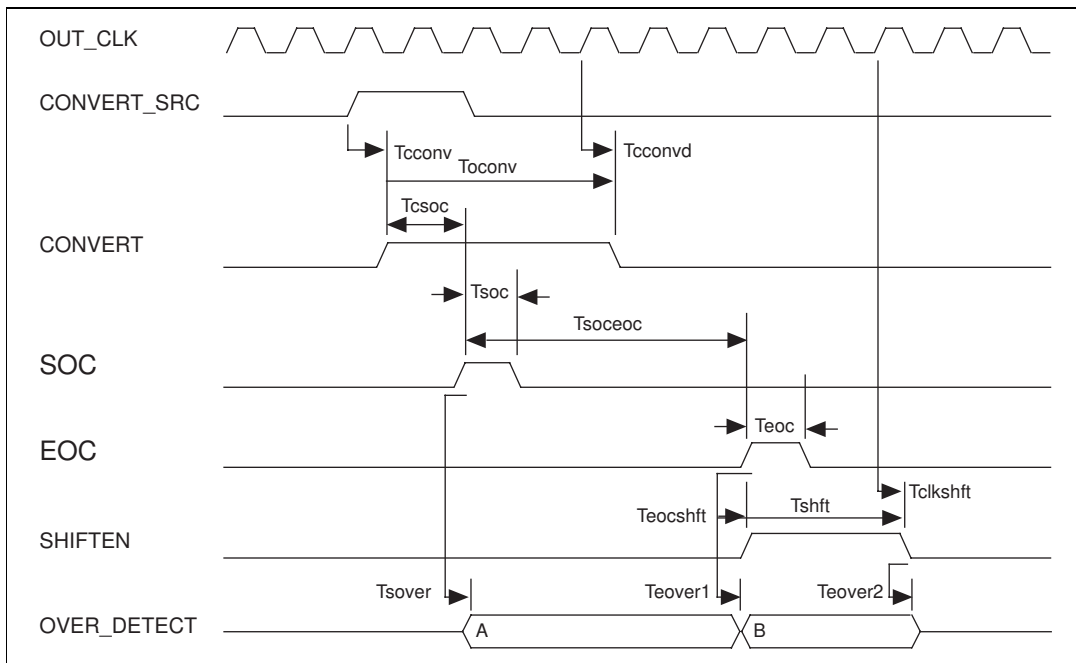

Figure 2-16. Basic Analog Input Timing

Table 2-3. Basic Analog Input Timing

Name	Description	Minimum	Maximum
T _{conv}	CONVERT_SRC to CONVERT (internal convert)	19	58
—	CONVERT_SRC to CONVERT (external convert)	21	65
T _{convd}	OUT_CLK to CONVERT deasserted	12	38
T _{oconv}	CONVERT width	(0.5, 1.5)	(1, 2)
T _{soconv}	SOC pulsewidth	6	—
T _{soceoc}	SOC precedes EOC	25	—
T _{eoconv}	EOC pulsewidth	6	—
T _{soeshft}	EOC to SHIFTIN asserted	7	21

Table 2-3. Basic Analog Input Timing (Continued)

Name	Description	Minimum	Maximum
Tshft	SHIFTIN pulsewidth	(0.5, 1.5)	(1.5, 2.5)
Tclkshft	OUT_CLK to SHIFTIN deasserted	13	38
Tsover	Begin overrun detection	10	—
Teover1	End overrun-detection mode 0	—	10
Teover2	End overrun-detection mode 1	—	0
Tcsoc	CONVERT to SOC	—	40

All timing values are in nanoseconds.

Figure 2-16 depicts a CONVERT pulse whose pulsewidth is determined by the output control circuit. The CONVERT pulsewidth may also be selected to be equal to the signal that generates the pulse (refer to AI_CONVERT_Pulse_Timebase). The SOC input notifies the DAQ-STC that a conversion has been started. Similarly, the EOC input notifies the DAQ-STC that a conversion has been completed. The assertion of EOC leads to the assertion of SHIFTIN, which you can use to load the acquisition data into its destination.

An overrun error occurs when the sampling rate is too high for the A/D subsystem to maintain. The time regions in which the DAQ-STC can detect an overrun error are shown by the line OVER_DETECT. If a second CONVERT signal occurs during the indicated portion, AI_Overrun_Error is set to 1 and an Error interrupt is generated (if the Error interrupt is enabled). Use AI_Overrun_Mode to configure the detect region to best match the A/D subsystem by selecting whether an overrun error should be detected in just the interval labeled A or in both intervals A and B. You should include the B region in the overrun detection for ADCs that tri-state or otherwise output invalid data after the CONVERT signal is asserted. This is due to the use of the trailing edge of the SHIFTIN signal to latch the A/D data for most applications.

The numbers in parentheses refer to the number of clock periods that will occur at the minimum and maximum delays, because those parameters are clock-edge driven with possible additional gate delays.

The CONVERT signal can be programmed to be one or two OUT_CLK periods (refer to AI_CONVERT_Pulse_Width). The CONVERT synchronization circuit counts either two or four OUT_CLK edges, regardless of polarity. The EOC input must be connected for the proper operation of SHIFTIN, which is asserted on the active edge of EOC. SHIFTIN is held for a falling clock edge and then one or two rising edges (refer to AI_SHIFTIN_Pulse_Width).

2.7.3 Data FIFOs

In addition to the SHIFTIN signal, the input signals AIFFF, AIFHF, and AIFEF and the output signal AIFREQ are available for interfacing to a data FIFO.

The SHIFTIN signal is used to write the data into the FIFO, and the CPU or a DMA controller will typically read those values. The FIFO flags will change only after a read, a write, a retransmit, or a FIFO reset. The AIFREQ signal is based on these FIFO flags, as well as on the last TC of the SC counter.

AIFREQ can be configured internally to generate interrupt requests (refer to AI_FIFO_Interrupt_Enable) and can be used externally for such purposes as generating DMA requests. The timing for these signals is shown in Figure 2-17.

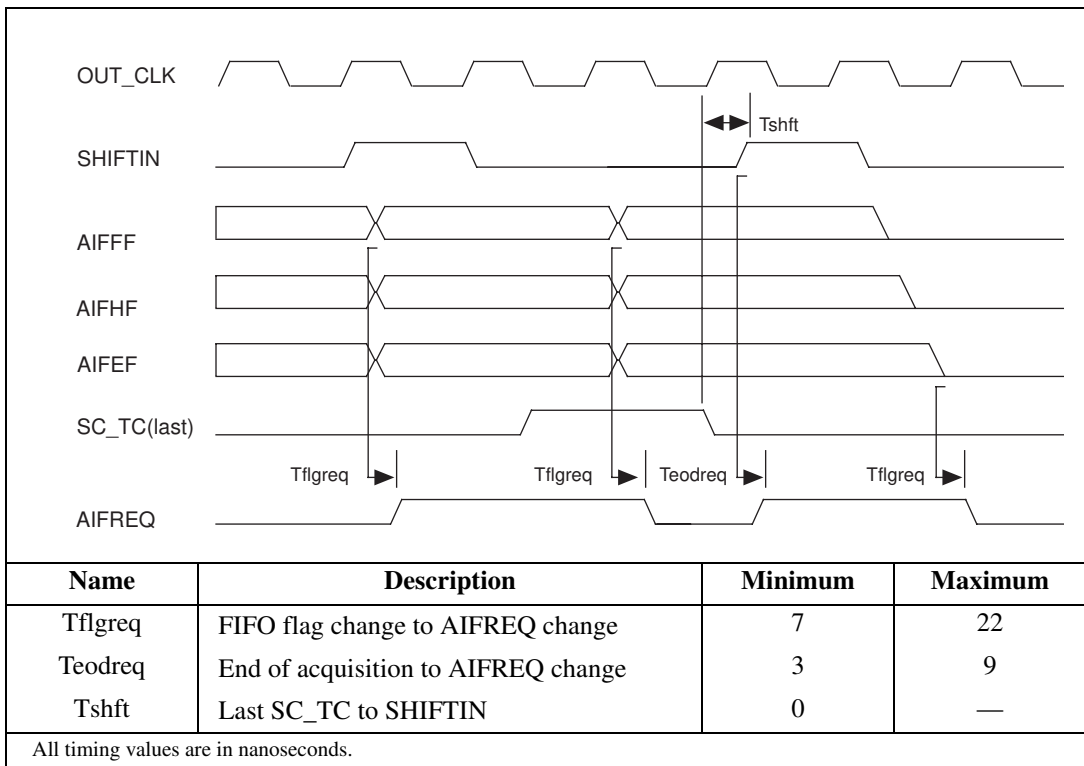

Figure 2-17. Data FIFO Timing

2.7.4 Configuration Memory

The DAQ-STC fully supports the FIFO-based configuration memory that can be incremented on every conversion pulse. The related signals are the outputs LOCALMUX_CLK, EXTMUX_CLK, EXTSTROBE, and LOCALMUX_FFRT and the input MUXFEF. These are shown in Figure 2-18.

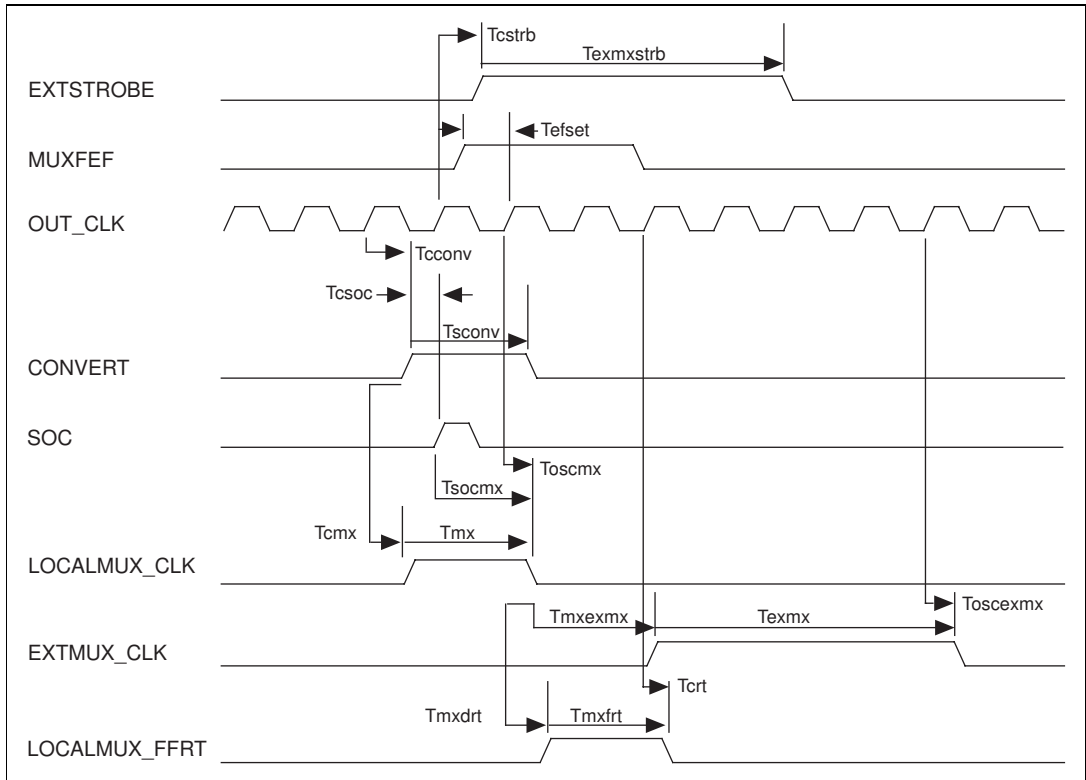

Figure 2-18. Configuration Memory Timing

In Figure 2-18 the CONVERT pulse is generated internally and has a pulsewidth equal to the signal that generates the pulse (one source clock period). The LOCALMUX_CLK signal reads the next word of data from the configuration memory and is asserted by the CONVERT signal. When an external multiplexer is being used, the LOCALMUX_CLK signal can be programmed to occur every n conversions, allowing a single data word in the configuration memory to be applied to multiple external channels.

The EXTMUX_CLK increments the external multiplexer and is generated once for every CONVERT pulse. The DIV counter is used to count the CONVERT pulses and allows the LOCALMUX_CLK signal to be generated during the DIV TC.

The actual signal timing parameters remain the same whether or not the DIV counter is being used. The EXTSTROBE signal is intended to be used in conjunction with the digital I/O lines to write data to an external multiplexer but can be used as a general strobe signal.

Table 2-4. Configuration Memory Timing

Name	Description	Minimum	Maximum
Tcconv	OUT_CLK to CONVERT asserted	19	58
Tsconv	CONVERT pulsewidth	(1)	(1)
Tmx	LOCALMUX_CLK pulsewidth	(0.5, 1.5)	(1, 2)
Texmx	EXTMUX_CLK pulsewidth	(4.5)	(4.5)
Tsocmx	SOC to LOCALMUX_CLK deasserted	9	26
Toscmx	OUT_CLK to LOCALMUX_CLK deasserted	13	40
Tcmx	CONVERT to LOCALMUX_CLK asserted	3	8
Tmxexmx	LOCALMUX_CLK to EXTMUX_CLK asserted	(1)	(1.5)
Toscevmx	Minimum EXTMUX_CLK from OUT_CLK	—	36
Tefset	MUXFEF setup to end of LOCALMUX_CLK	21	—
Tmxdrf	End of LOCALMUX_CLK to LOCALMUX_FFRT asserted	—	0
Tmxfrf	LOCALMUX_FFRT pulsewidth	(0.5, 1)	(0.5, 1)
Tcrt	OUT_CLK to LOCALMUX_FFRT deasserted	11	35
Tcstrb	OUT_CLK to EXTSTROBE change	11	36
Texmxstrb	EXTSTROBE pulsewidth (see DIO_HW_Serial_Timebase)	(1)	(1)
Tcsoc	CONVERT to SOC	—	40

All timing values are in nanoseconds.

The numbers in parentheses refer to the number of clock periods that will occur at the minimum and maximum delays, because those parameters are clock-edge driven with possible additional gate delays.

The trailing edge of LOCALMUX_CLK should be used to latch the new configuration information, which in general should not change until the input signal has been sampled. The LOCALMUX_CLK signal is asserted by the leading edge of CONVERT and is held for either two or four output clock edges, regardless of polarity, and then until the active edge of SOC

(refer to `AI_LOCALMUX_CLK_Pulse_Width`). This provides a fixed minimum pulsewidth but guarantees that the configuration data does not change until the input signal has been sampled.

The `EXTMUX_CLK` controls the external multiplexer with one of two options and is generated at every conversion. In the first option, the `EXTMUX_CLK` is asserted by `CONVERT` and is identical in length to the `LOCALMUX_CLK` signal. In the second option, the trailing edge of `LOCALMUX_CLK` is latched and, after one falling and one rising edge of the output clock, `EXTMUX_CLK` is asserted. `EXTMUX_CLK` is then held for 4.5 clock periods (refer to `AI_EXTMUX_CLK_Pulse_Width`).

The input signal `MUXFEF` indicates that the configuration memory has been emptied, and should be reset. The `LOCALMUX_FFRT` signal is asserted on the trailing edge of the `LOCALMUX_CLK` signal and is deasserted after one or two output clock edges. Notice that both the `LOCALMUX_CLK` and `LOCALMUX_FFRT` signals are controlled by `AI_LOCALMUX_CLK_Pulse_Width`; therefore, they will both be at either their shortest or longest settings.

The `EXTSTROBE` signal has two modes of operation. It can be either a string of eight 1.2 or 10 μ s pulses or a software toggle.

2.7.5 Maximum Rate Analog Input

When running the analog input at its maximum conversion rate, the `LOCALMUX_CLK` and `LOCALMUX_FFRT` signals should be programmed to their shortest pulsewidths for correct operation, as shown in Figure 2-19. This diagram also shows that the maximum conversion rate is equal to one half the output clock rate. Up to 10 MS/s is achievable with a 20 MHz oscillator, and up to 5 MS/s is achievable with a 10 MHz oscillator.

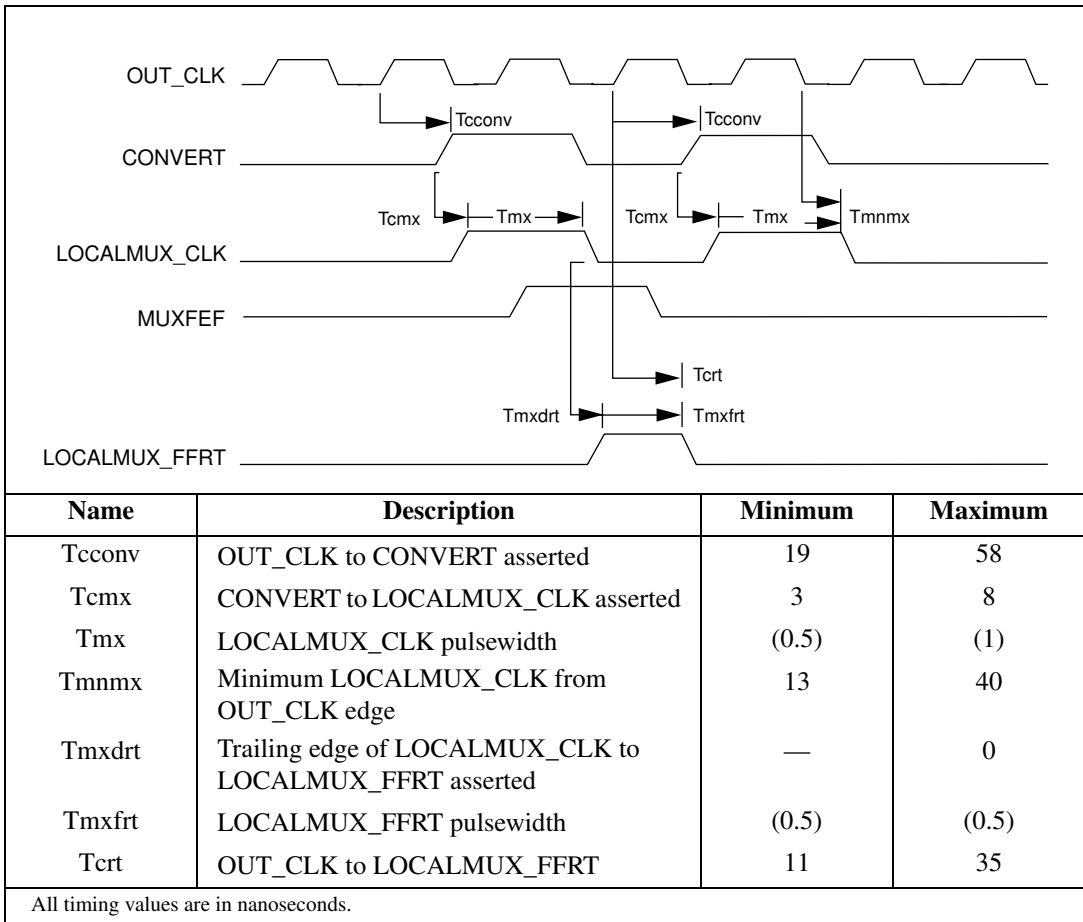

Figure 2-19. Maximum Rate Analog Input Timing

The numbers in parentheses refer to the number of clock periods that will occur at the minimum and maximum delays, because those parameters are clock-edge driven with possible additional gate delays.

2.7.6 External CONVERT Source

The DAQ-STC provides a very flexible architecture to control data acquisition from an external conversion source, such as the MIO board or RTSI connectors.

The internal control circuits are driven by CONVERT_SRC. In the internal CONVERT mode, CONVERT_SRC is equal to OSC (or RTSI_OSC). In the external CONVERT mode, CONVERT_SRC is selected to be one of the PFI<0..9> or RTSI_TRIGGER<0..6> inputs. The timing for CONVERT_SRC in the external CONVERT mode is shown in Figure 2-20.

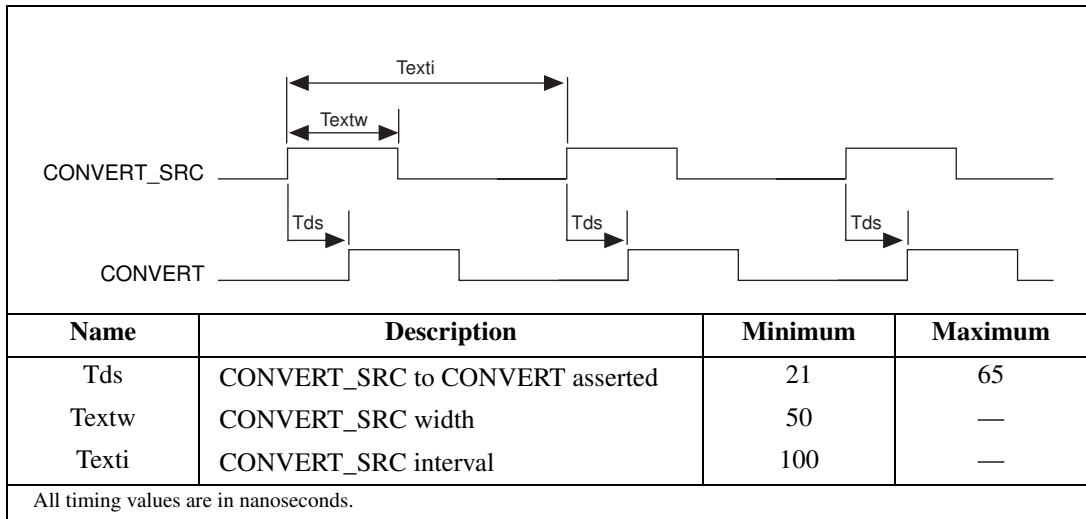

Figure 2-20. External CONVERT_SRC Timing

2.7.7 External Triggers

Each of the external signals will be latched and recognized by the DAQ-STC in one of two configurations. The latching of the external signal generates an internal version of the signal, which the internal control circuit uses. The control circuit then can recognize the internal signal and change state. The latching and recognition of the external signal are software programmable to occur in synchronous mode or asynchronous mode. In synchronous mode, the DAQ-STC is internally synchronizing the signal to prevent metastability. In asynchronous mode, the external signal must already be synchronized to the state clock, allowing the DAQ-STC to use the signal directly.

Each of the external inputs to the DAQ-STC can be edge or level sensitive. The level-sensitive signals are passed directly to the latch and recognition circuitry. The edge-sensitive mode generates an intermediate internal signal by prelatching the external signal at its active edge. This intermediate signal is routed to the latching and recognition circuitry. The edge-sensitive mode has only a pulsewidth requirement, but in order to guarantee recognition by a specific clock edge it must also meet the setup time to the latching state clock edge.

The four modes resulting from the combination of the above options are shown in Figures 2-21 through 2-26. The four modes are asynchronous-level sensitive, asynchronous-edge sensitive, synchronous-level sensitive, and synchronous-edge sensitive.

In synchronous mode, the synchronizing edge depends on whether you select internal CONVERT or external CONVERT. In the internal CONVERT mode, the external signal synchronizes to the inactive edge of the SI2 source. In the external CONVERT mode, the external signal synchronizes to the active edge of CONVERT_SRC.

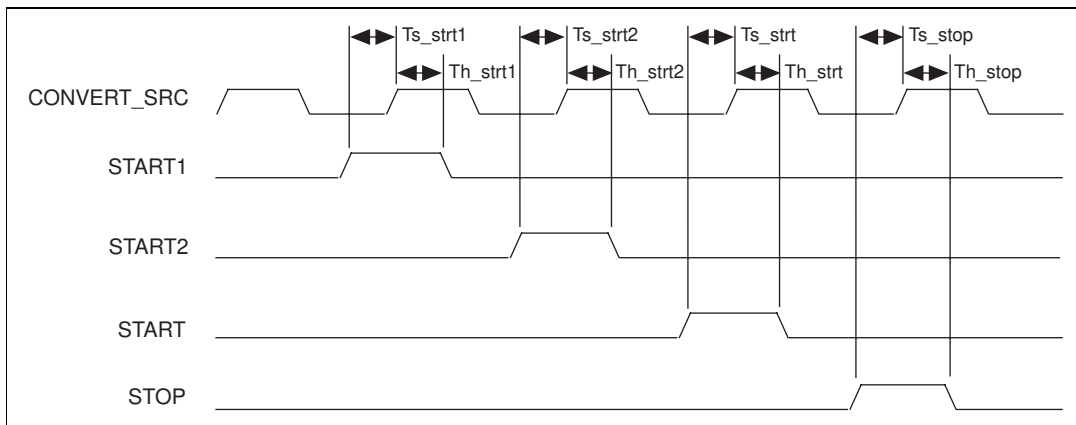

Figure 2-21. External Trigger Timing, Asynchronous Level

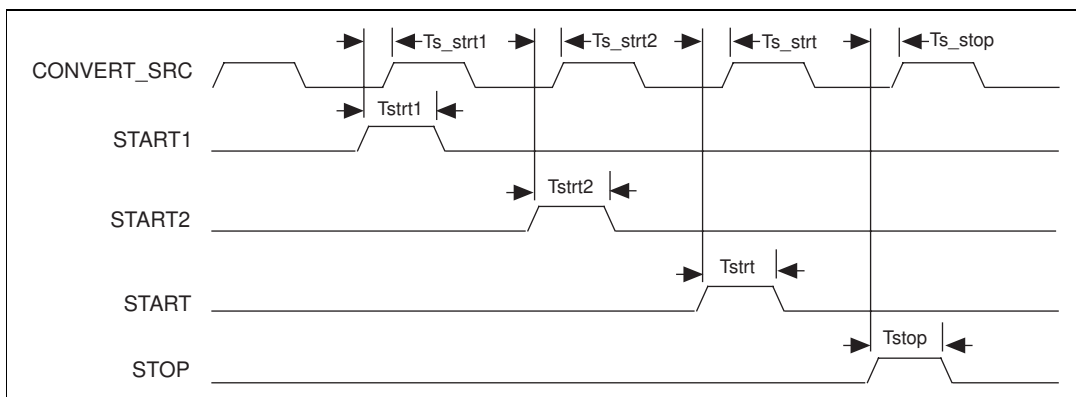

Figure 2-22. External Trigger Timing, Asynchronous Edge

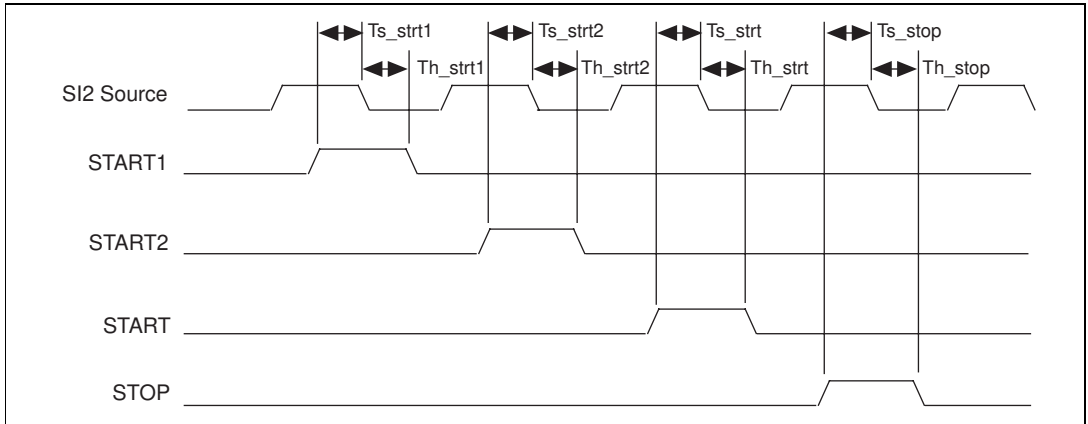

Figure 2-23. External Trigger Timing, Synchronous Level, Internal CONVERT Mode

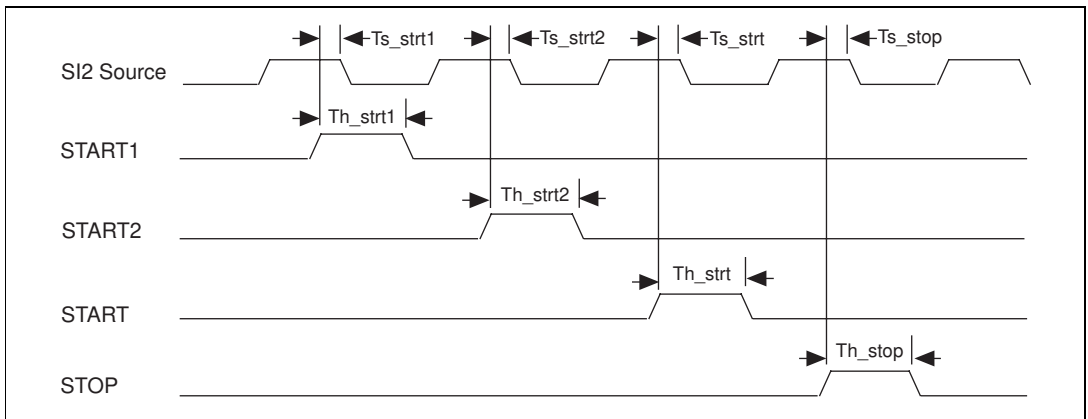

Figure 2-24. External Trigger Timing, Synchronous Edge, Internal CONVERT Mode

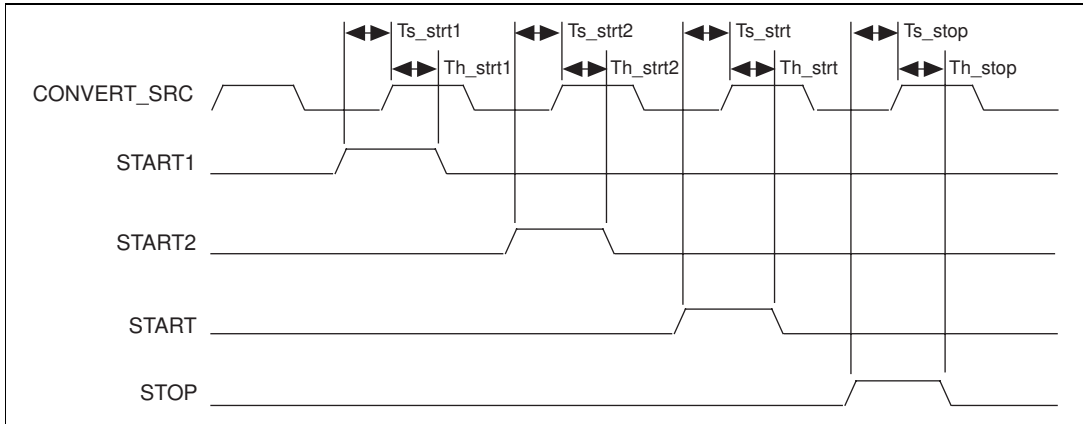

Figure 2-25. External Trigger Timing, Synchronous Level, External CONVERT Mode

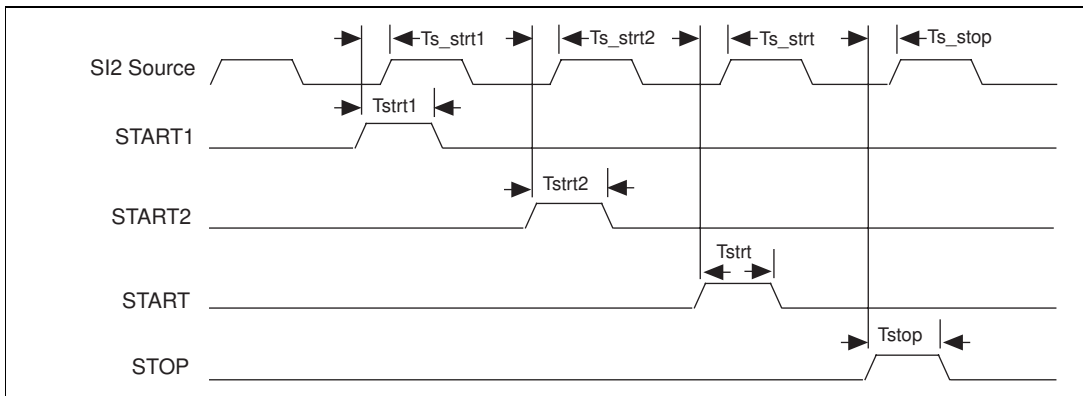

Figure 2-26. External Trigger Timing, Synchronous Edge, External CONVERT Mode

Table 2-5. External Analog Input Timing

Name	Description	Minimum	Maximum
Ts_strt1	START1 setup to CONVERT_SRC	33 (36)	—
Tstrt1	START1 pulsewidth (edge mode)	6	—
Th_strt1	START1 hold from CONVERT_SRC (level mode)	4	—
Ts_strt2	START2 setup to CONVERT_SRC	31 (34)	—
Tstrt2	START2 pulsewidth (edge mode)	6	—
Th_strt2	START2 hold from CONVERT_SRC (level mode)	4	—
Ts_strt	START setup to CONVERT_SRC	29 (32)	—

Table 2-5. External Analog Input Timing (Continued)

Name	Description	Minimum	Maximum
Tstrt	START pulsewidth (edge mode)	6	—
Th_strt	START hold from CONVERT_SRC (level mode)	4	—
Ts_stop	STOP setup to CONVERT_SRC	31 (34)	—
Tstop	STOP pulsewidth (edge mode)	6	—
Th_stop	STOP hold from CONVERT_SRC (level mode)	4	—

All timing values are in nanoseconds.

The numbers in parentheses indicate edge-gating mode, depending on which mode you specify in AI_START1_Edge, AI_START2_Edge, AI_START_Edge, or AI_STOP_Edge.

2.7.8 Trigger Output

You can output the internal triggers to the board through the PFI or RTSI interface. This section lists the propagation delays for the triggers when you configure the triggers for output to the board.

2.7.8.1 START1 and START2 Triggers

You can output the START1 trigger on the PFI output PFI0/AI_START1 or on any RTSI output. You can output the START2 trigger on the PFI output PFI1/AI_START2 or on any RTSI output. Timing for START1 and START2 depends on whether you select synchronous mode or asynchronous mode, using AI_START1_Sync and AI_START2_Sync.

Synchronous Mode

When you select synchronous mode for START1 or START2, the timing depends on whether you select internal CONVERT or external CONVERT, using AI_CONVERT_Source_Select. In the internal CONVERT mode, the inactive edge of the SI2 source that recognizes the external trigger generates the output. Figure 2-27 shows the propagation delays for START1. Figure 2-28 shows the propagation delays for START2.

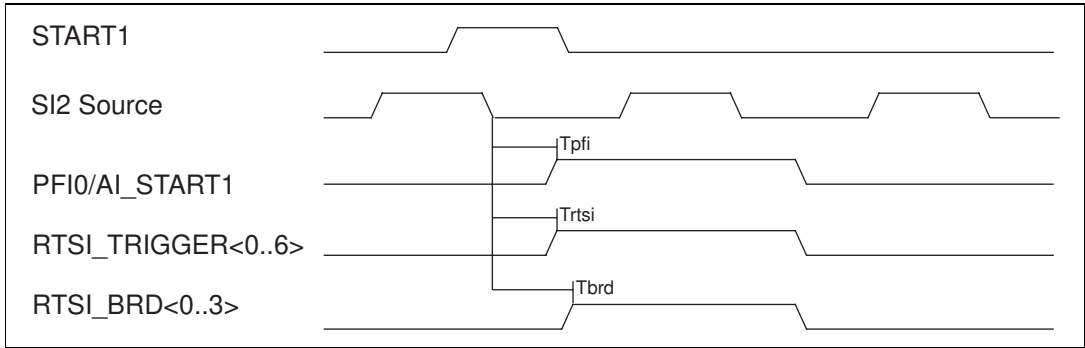

Figure 2-27. START1 Delays, Synchronous Mode, Internal CONVERT

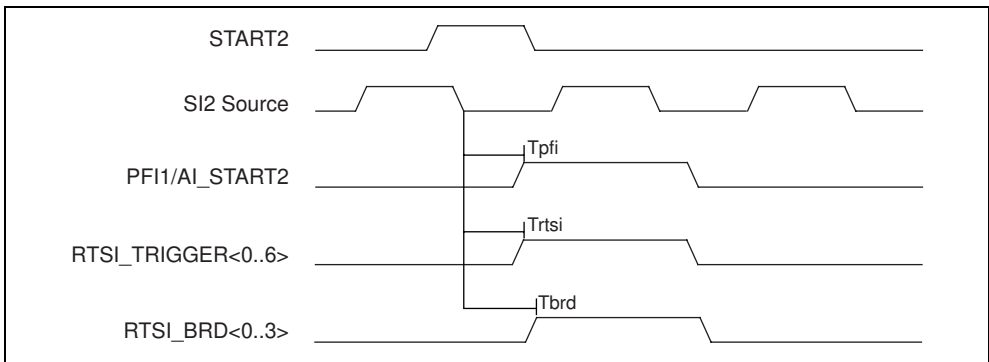

Figure 2-28. START2 Delays, Synchronous Mode, Internal CONVERT

In the external CONVERT mode, the active edge of CONVERT_SRC that recognizes the external trigger generates the output. Figure 2-29 shows the propagation delays for START1. Figure 2-30 shows the propagation delays for START2.

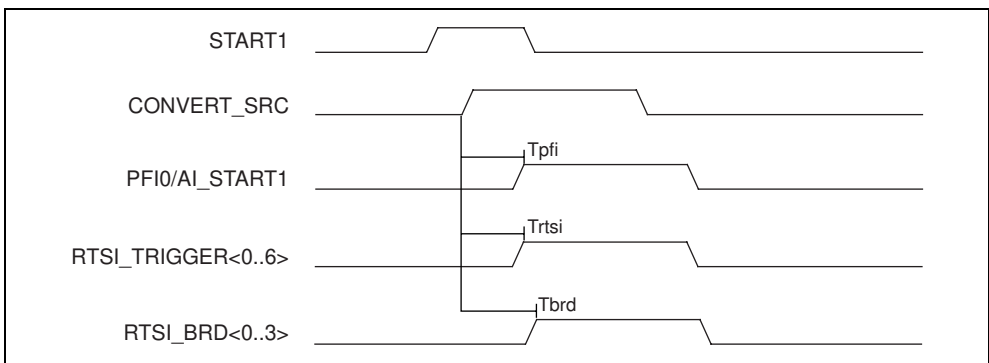

Figure 2-29. START1 Delays, Synchronous Mode, External CONVERT

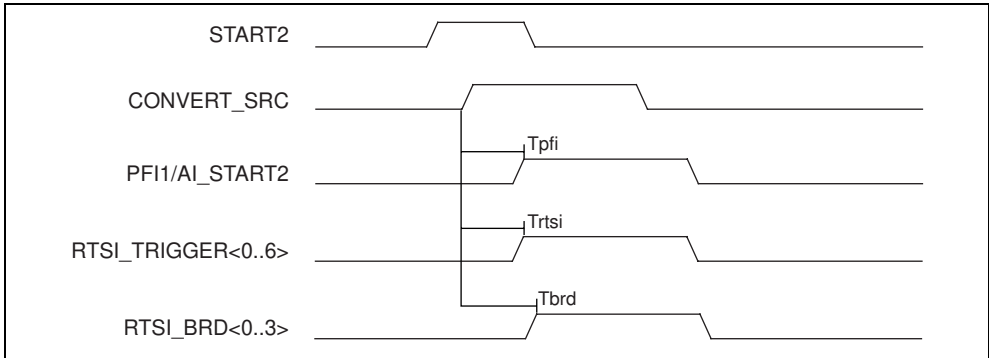

Figure 2-30. START2 Delays, Synchronous Mode, External CONVERT

Table 2-6. START1 and START2 Timing, Synchronous Mode

Name	Description	Minimum	Maximum
T _{pfi}	Source to PFI output	10	41
T _{rtsi}	Source to RTSI output	12	46
T _{brdr}	Source to BRD output	18	63

All timing values are in nanoseconds.

Asynchronous Mode

When you select asynchronous mode for START1 or START2, the external trigger itself generates the rising edge of the output. Figure 2-31 shows the propagation delays for START1. Figure 2-32 shows the propagation delays for START2.

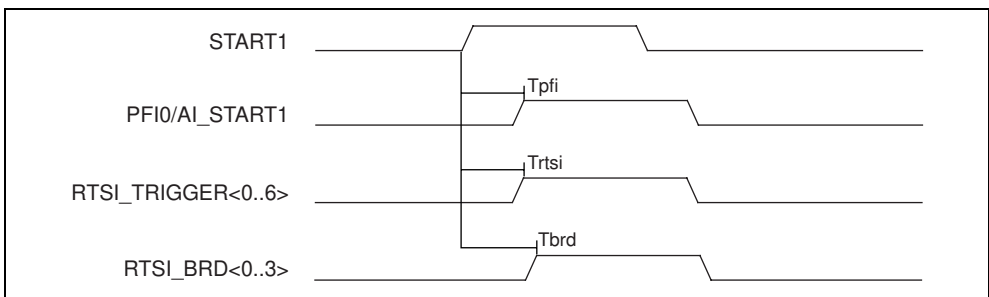

Figure 2-31. START1 Delays, Asynchronous Mode

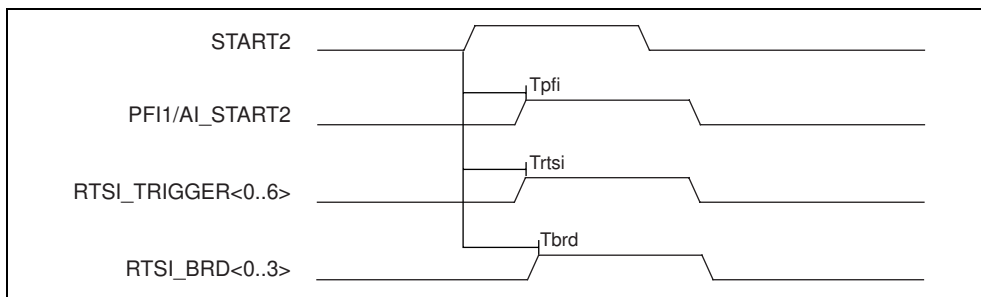

Figure 2-32. START2 Delays, Asynchronous Mode

Table 2-7. START1 and START2 Timing, Asynchronous Mode

Name	Description	Minimum	Maximum
T _{pfi}	Trigger to PFI output	8	31
T _{rtsi}	Trigger to RTSI output	10	36
T _{brd}	Trigger to BRD output	16	53

All timing values are in nanoseconds.

2.7.8.2 START Trigger and SCAN_IN_PROG Assertion

You can output the START trigger on the PFI output PFI7/AI_START or on the RTSI_BRD<2..3> outputs. You can output SCAN_IN_PROG on the SCAN_IN_PROG pin, PFI7/AI_START, or on the RTSI_BRD<2..3> outputs. The timing for START and SCAN_IN_PROG depends on whether you select internal CONVERT or external CONVERT, using AI_CONVERT_Source_Select. This section assumes AI_Delay_Start is set to 0.

Internal CONVERT Mode

In the internal CONVERT mode, the START and SCAN_IN_PROG outputs are generated by the inactive edge of the SI2 source that recognizes START. You can select the pulsewidth of the START pulse using AI_Trigger_Length. Figure 2-33 shows the propagation delays for START and SCAN_IN_PROG in the internal CONVERT mode.

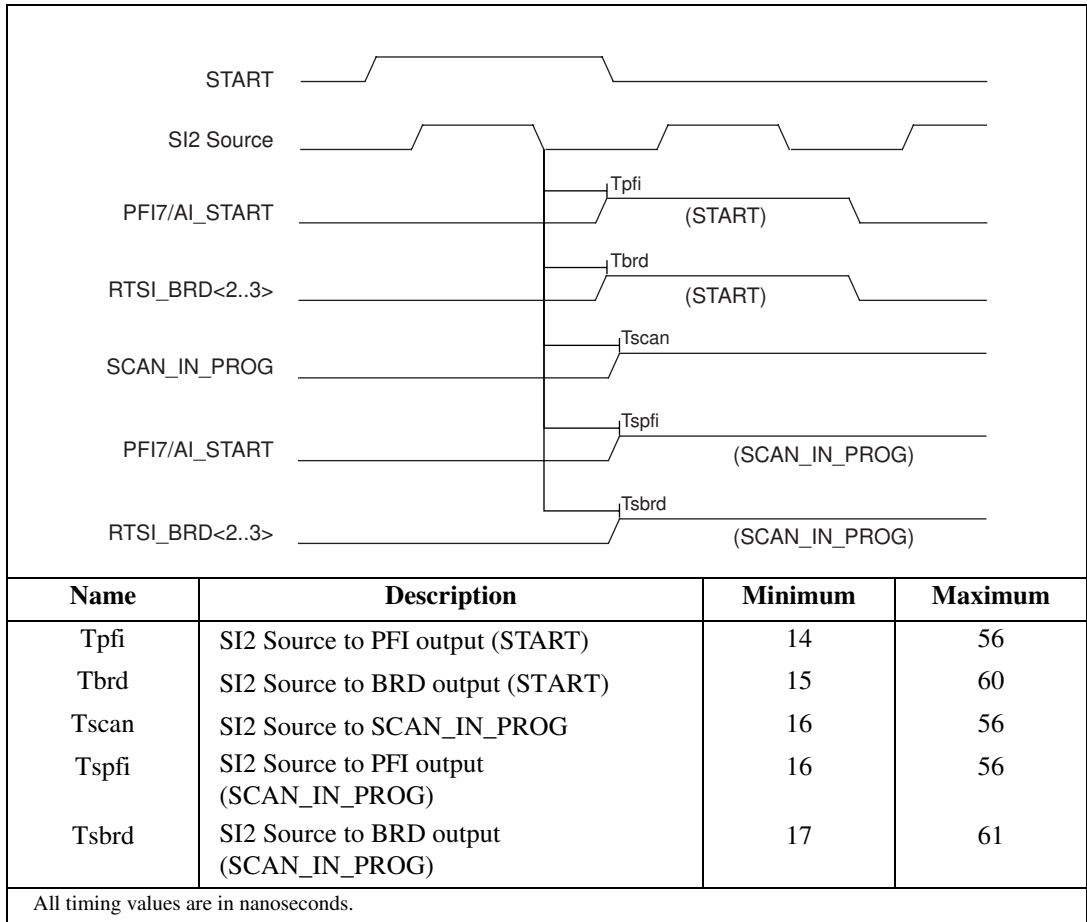

Figure 2-33. START Delays, Internal CONVERT

External CONVERT Mode

In the external CONVERT mode, the START and SCAN_IN_PROG outputs are generated by the active edge of the CONVERT source that recognizes START. If you set AI_Trigger_Length to 0, both edges of the START pulse are generated by the same edge of the CONVERT source. If you set AI_Trigger_Length to 1, the START pulse is stretched. Figure 2-34 shows the propagation delays for START and SCAN_IN_PROG in the external CONVERT mode. The deassertion delay for PFI7/AI_START is indicated for the case where AI_Trigger_Length is set to 0.

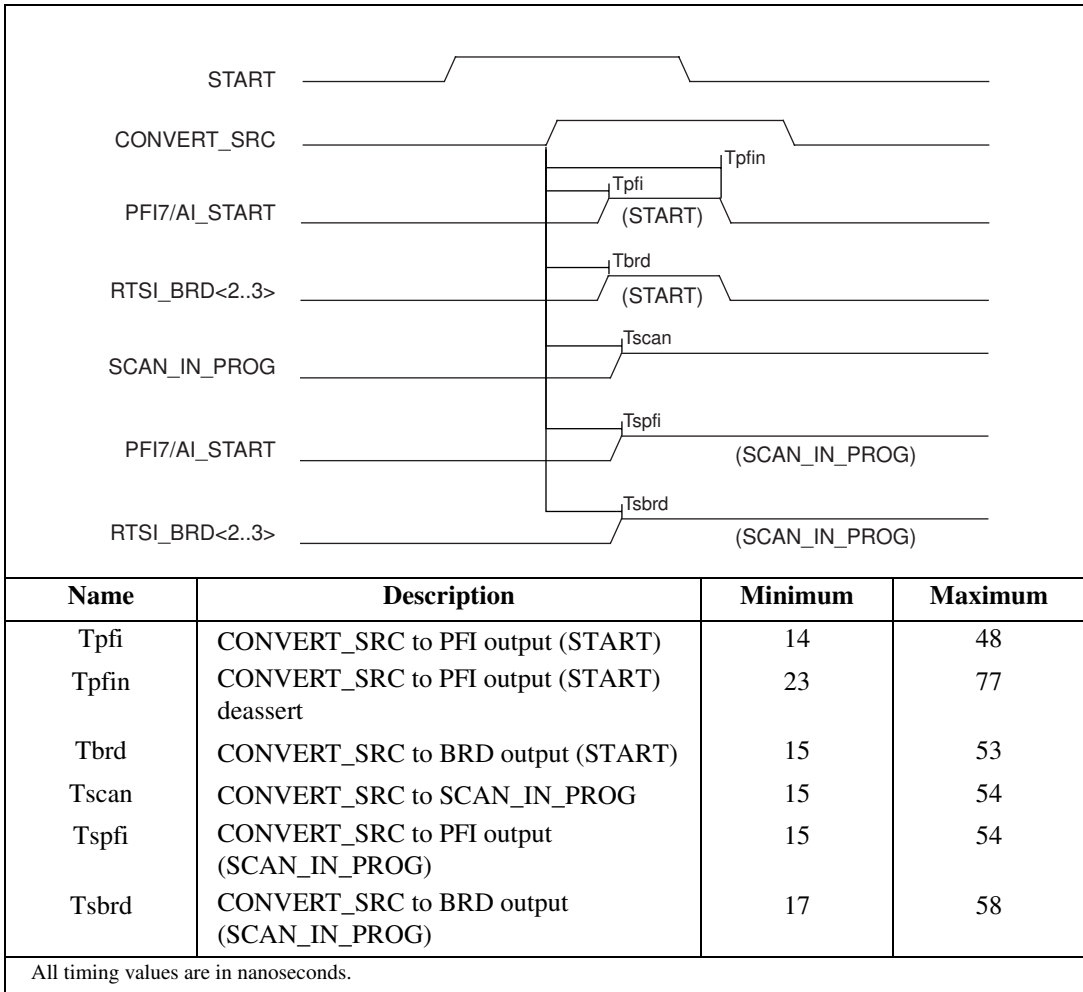

Figure 2-34. START Delays, External CONVERT

2.7.8.3 SCAN_IN_PROG Deassertion

You can output SCAN_IN_PROG on the SCAN_IN_PROG pin, PFI7/AI_START, or the RTSI_BRD<2..3> outputs. If AI_External_Mux_Present is 0, SCAN_IN_PROG deasserts on the SOC edge that occurs while STOP is asserted. If AI_External_Mux_Present is 1, SCAN_IN_PROG deasserts on the SOC edge that occurs while STOP and DIV_TC are both asserted. Figure 2-35 shows the behavior of the SCAN_IN_PROG outputs during deassertion.

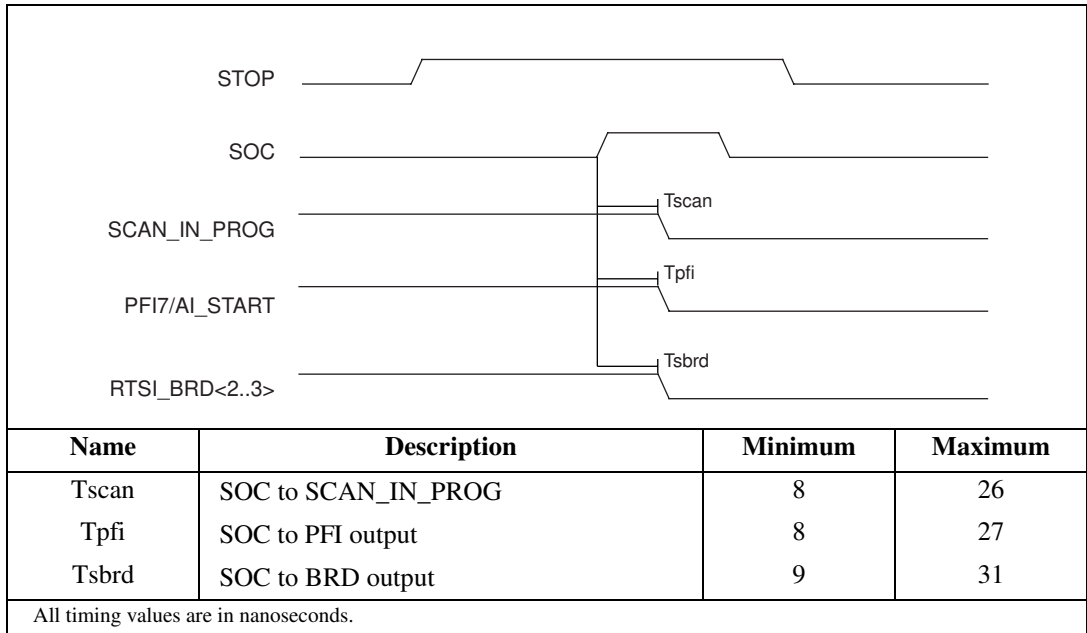

Figure 2-35. SCAN_IN_PROG Deassertion

2.7.8.4 STOP Trigger

You can output the STOP trigger on the dedicated output AI_STOP_OUT or on the RTSI_BRD<0..1> pins. The timing for STOP depends on whether you select synchronous mode or asynchronous mode, using AI_STOP_Sync.

Synchronous Mode

In synchronous mode, the STOP outputs change on the CONVERT source edge following a change in the external trigger. Figure 2-36 shows the behavior of the STOP output in synchronous mode.

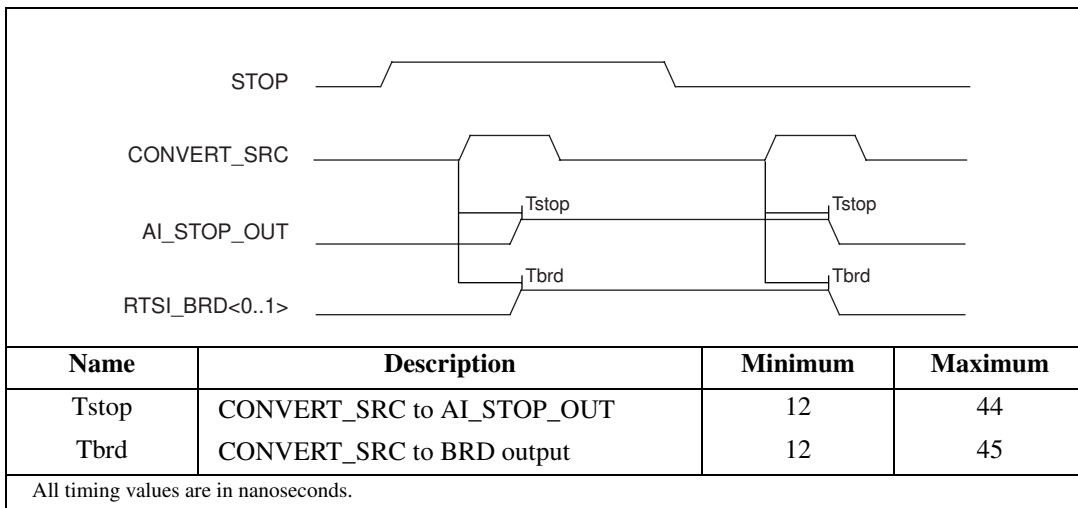

Figure 2-36. STOP Delay, Synchronous Mode

Asynchronous Mode

In asynchronous mode, the STOP outputs follow the external trigger. Figure 2-37 shows the behavior of the STOP outputs in asynchronous mode.

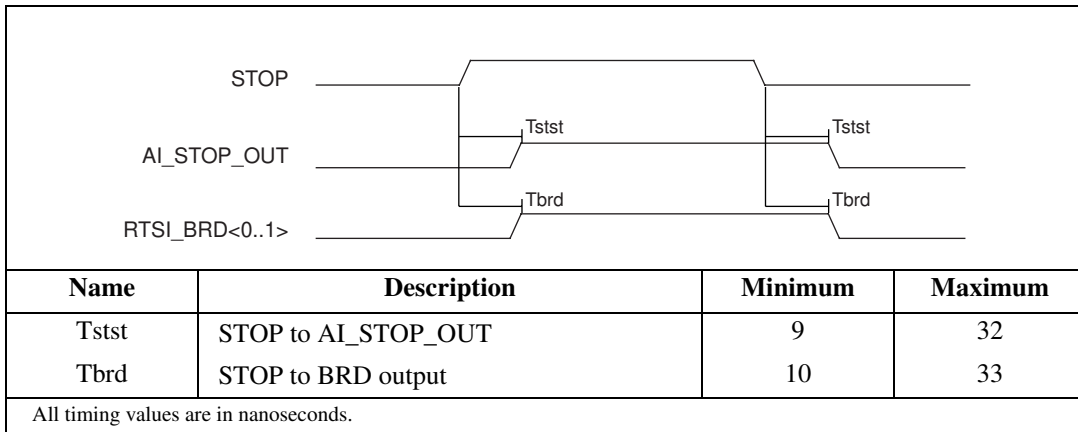

Figure 2-37. STOP Delay, Asynchronous Mode

2.7.9 Counter Outputs

You can output the internal counter TC signals to the board. This section presents the output timing for the SC_TC, SI_TC, and DIV_TC outputs.

2.7.9.1 SC_TC

Figure 2-38 shows the delays associated with the SC_TC signal. In internal CONVERT mode, the SC source is OSC. In external CONVERT mode, the SC source is a delayed version of the external CONVERT source. For this reason, SC_TC has additional delay in external CONVERT mode.

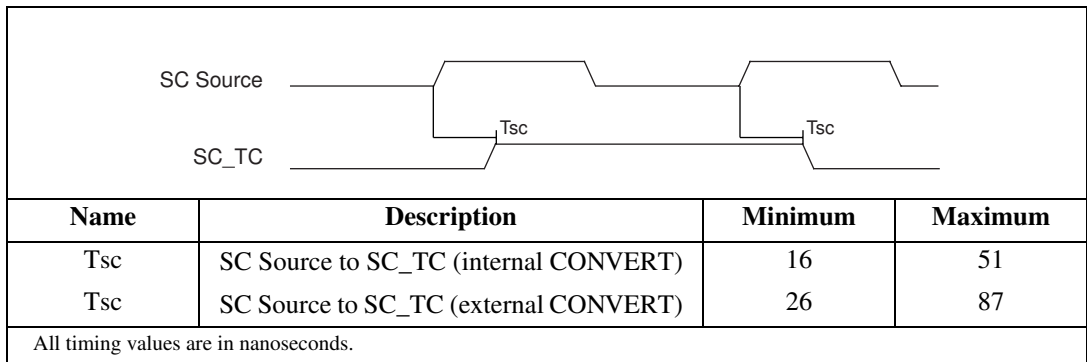

Figure 2-38. SC_TC Delay

2.7.9.2 SI_TC

Figure 2-39 shows the delays associated with the SI_TC signal.

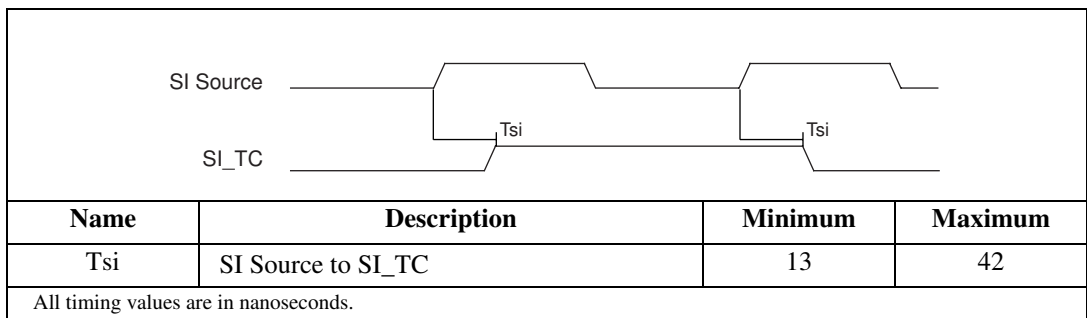

Figure 2-39. SI_TC Delay

2.7.9.3 DIV_TC

Figure 2-40 shows the delays associated with the DIV_TC signal.

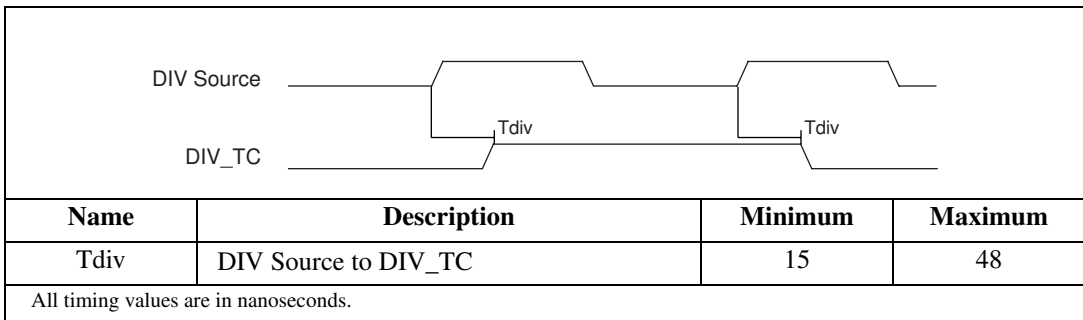

Figure 2-40. DIV_TC Delay

2.7.10 Macro-Level Analog Input Timing

The interval scanning mode provides pseudosimultaneous operation, in which a group of channels is sampled at one rate, and the sampling of channels within a group occurs at another rate. The timing for this mode is shown in Figure 2-41.

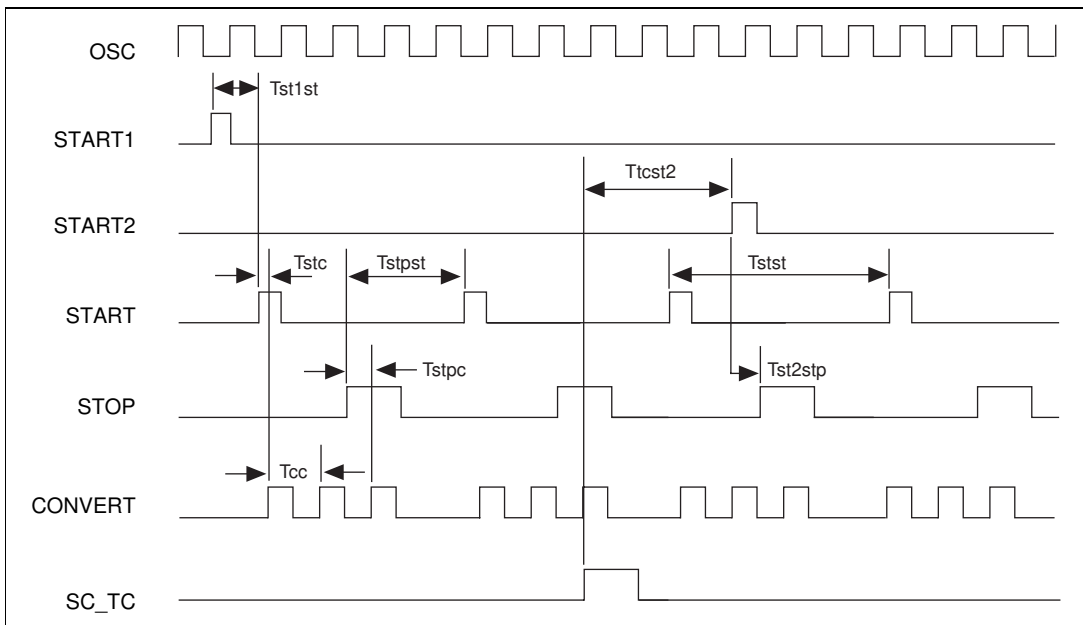

Figure 2-41. Interval Scanning Mode Timing

Table 2-8. Interval Scanning Mode Timing

Name	Description	External Control	Minimum in Clock Periods	Maximum in Clock Periods
Tst1st	START1 to START	0	1 (1)	$2^{24}-1$ ($2^{24}-1$)
Tstst	START to START	2	2 (1)	$2^{24}-1$ ($2^{24}-1$)
Tstc	START to CONVERT	0	1 (1)	$2^{24}-1$ ($2^{24}-1$)
Tcc	CONVERT to CONVERT	2	2 (1)	2^{16} ($2^{16}-1$)
Tstpc	STOP to CONVERT	0	0	—
Tstpst	STOP to START	0	0	—
Ttst2	SC_TC to START2	1	1	—
Tst2stp	START2 to STOP	1	1 (1)	$2^{24}-1$ ($2^{24}-1$)

The numbers in parentheses are the actual numbers to load into the on-chip counters to achieve the desired delay.

Table 2-8 shows the minimum number of clock periods that must occur between related signals in order for their recognition to be valid. Notice that this does not take into account the setup or synchronization time for the external signals, as covered in section 2.7.7, *External Triggers*. The External Control column is applicable when the signal is originating outside the DAQ-STC. The DAQ-STC minimum and maximum columns apply to the internally generated signals.

The START1 trigger is the only trigger in the posttrigger mode and is the first trigger in the pretrigger mode. It triggers the acquisition sequence and can be generated by software or by an external pulse (refer to AI_START1_Select). The software trigger, which is caused by setting AI_START1 to 1, generates the correct pulsewidth automatically. The external pulse must meet the latch and recognition-time parameters that are indicated in section 2.7.7, *External Triggers*, for its selected mode of operation.

The START trigger enables a particular scan and is generated by either an external signal or the internal signal SI_TC (refer to AI_START_Select). The SI counter is started by the START1 trigger and can be programmed to count anywhere from 2 to 2^{24} clock periods. The external signal must meet the setup and pulsewidth requirements indicated in section 2.7.7, *External Triggers*, in order to guarantee recognition by the AITM.

The CONVERT output signal causes an actual conversion to occur and can be caused either by an external signal or the internal signal SI2_TC, inverted (refer to AI_CONVERT_Source_Select). The SI2 counter is started by the START trigger and can be programmed to count anywhere from 2 to 2^{16} clock periods. The external signal must meet the setup and pulsewidth requirements that are indicated in section 2.7.7, *External Triggers*, in order to guarantee recognition by the AITM. The external signal can be passed through the

DAQ-STC or can be internally conditioned. The conditioning allows for a shorter CONVERT pulsewidth, as the signal is latched and held for two edges of OUT_CLK. The pass-through option passes the original external signal or truncates the external signal after two or four edges of the output clock. Because a very short pulse is possible, you should take extra care when allowing the signal to pass through the DAQ-STC (refer to AI_CONVERT_Pulse_Timebase).

The STOP trigger terminates the current scan and is generated by an external signal or a software strobe (refer to AI_STOP_Select). The external signal must meet the setup and pulsewidth requirements indicated in section 2.7.7, *External Triggers*, in order to guarantee recognition by the AITM. Although the STOP trigger can be asserted a large number of clock periods before the CONVERT signal, it must be held until the SOC for that CONVERT has been asserted.

The START2 trigger, which is used only in pretrigger acquisition mode, operates similarly to the START1 trigger. The START2 trigger is ignored until the proper number of pretrigger data points has been taken as indicated by the SC_TC signal. It is recognized by the current scan if it occurs before the STOP trigger. Otherwise, the following scan will be the first posttrigger point. Therefore, all of the scans in the pretrigger buffer will have completed before the assertion of the START2 signal.

2.7.11 External Gating

The DAQ-STC provides two modes of gating—free-run and halt-gating modes. Halt-gating mode provides the shortest guaranteed delay from the assertion of the gate to the next CONVERT pulse, while free-run mode provides deterministic timing for a scan regardless of how many scans were masked off prior to the current scan. Gating is controlled by either an external gate signal or a software strobe.

Timing for the external gate depends on whether you select internal CONVERT or external CONVERT, using `AI_CONVERT_Source_Select`. In internal CONVERT mode, the external gate is synchronized to the inactive edge of the `SI2` source. Figure 2-42 shows the timing for free-run gating mode with an internal CONVERT.

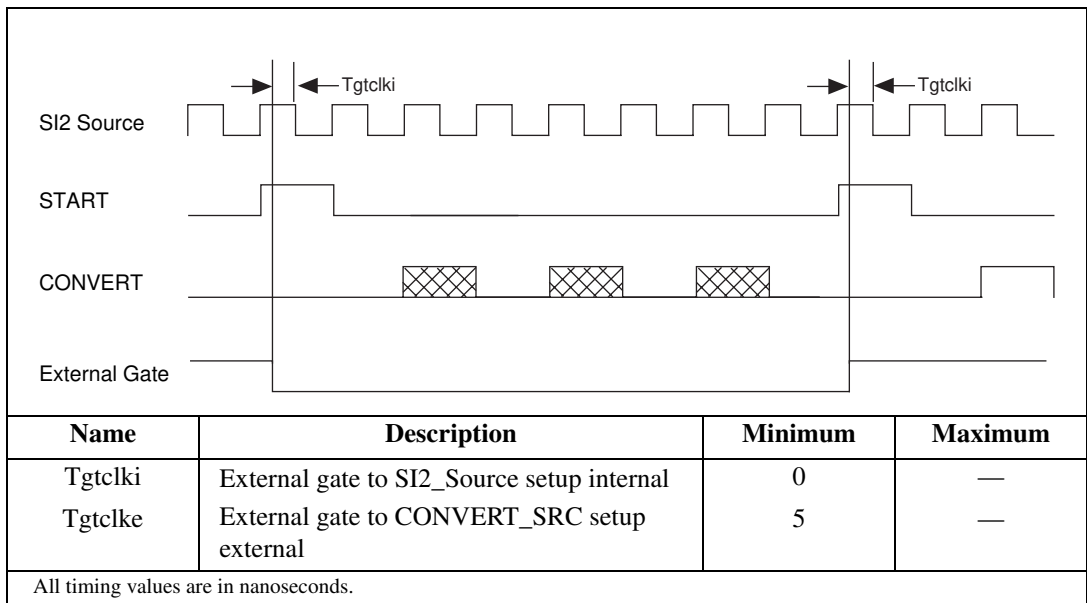

Figure 2-42. Free-Run Gating Mode Timing, Internal CONVERT

In external CONVERT mode, the external gate is synchronized to the active edge of CONVERT_SRC. Figure 2-43 shows the timing for free-run gating mode with an external CONVERT.

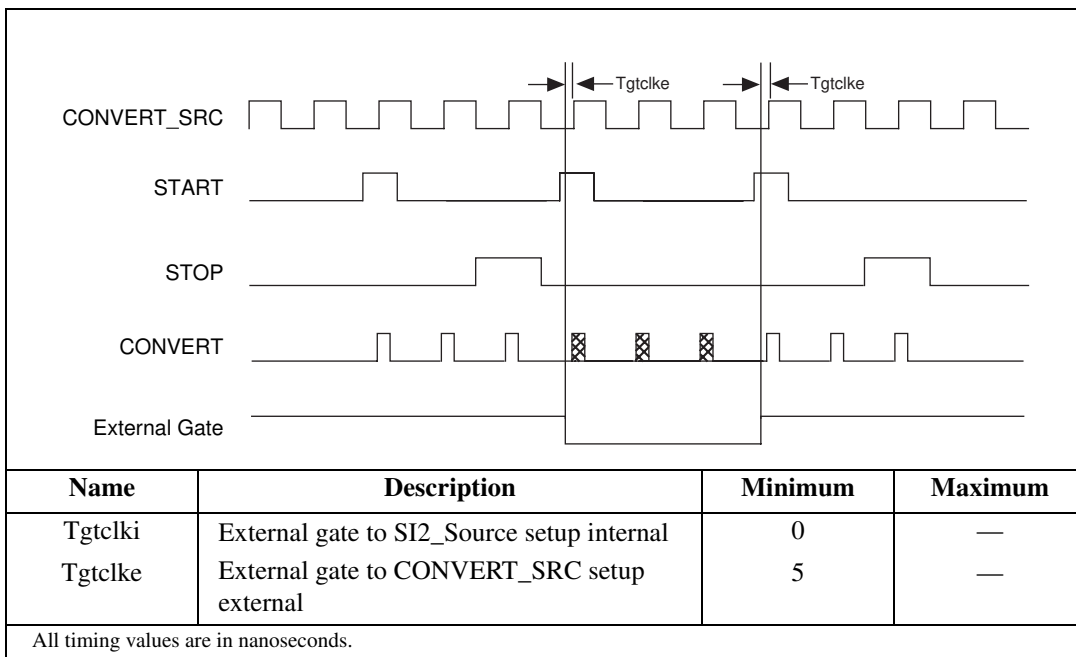

Figure 2-43. Free-Run Gating Mode Timing, External CONVERT

The shaded areas in Figures 2-42 and 2-43 indicate where those signals would be asserted had they not been gated off. The recognition of the external gate signal in the free-run gating mode is relative to the START signal.

Figure 2-44 shows the timing for the halt-gating mode with an internal CONVERT, where the SI2 source and SI source are the same signal.

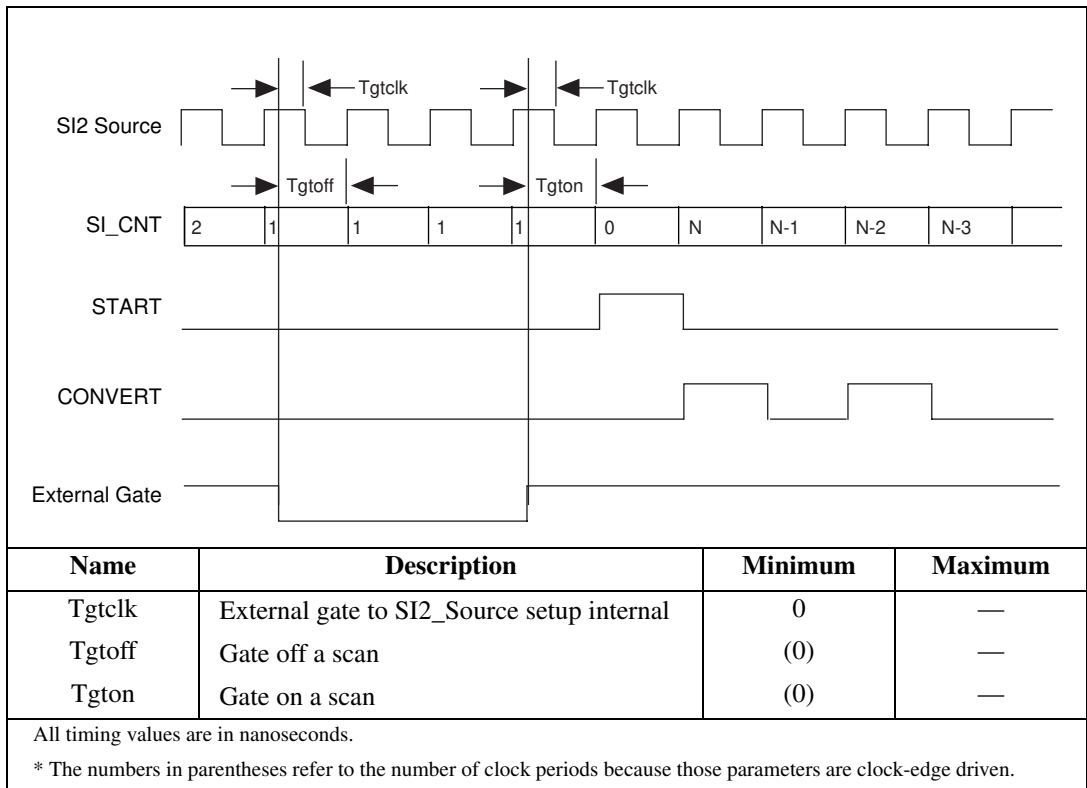

Figure 2-44. Halt-Gating Mode Timing, Internal CONVERT

The gate signal is always latched and recognized in the level-sensitive synchronous mode and is qualified by the SCAN_IN_PROG signal. A change in the GATE signal is not used internally while the SCAN_IN_PROG signal is asserted.

The recognition of the external gate signal in halt-gating mode is relative to the source clock and the SI counter. The external gate signal is latched on the falling edge and used on the rising edge, but it must be recognized prior to or at the same source clock edge as the SI counter counting down to zero. The SI counter stops at one and remains there until the external gate signal is deasserted. At that point the SI counter will decrement and generate the START signal, which begins the next scan.

The timing for the halt-gating mode with an external CONVERT or with SI2 source and SI source as different signals is more complicated and is, therefore, omitted.

2.8 Detailed Description

This section describes the AITM module in detail. You need not read this section unless you need to understand the inner workings of the circuit. This section refers to bitfields in the AITM-related registers in the DAQ-STC register map. Refer to Appendix B, *Register Information*, for more information on the register addresses containing these bitfields.

Figure 2-46 shows a block diagram of the AITM module. The AITM contains four special-purpose counters—SI, SI2, SC, and DIV. Each of the counters (except DIV) has dual-load registers (A and B), which allow the counters to handle two parameters for each timing layer, as discussed in section 2.4, *Analog Input Functions*. Apart from the counters, the primary logic blocks are the counter control blocks, the routing logic block, the interrupt control block, and the output control block.

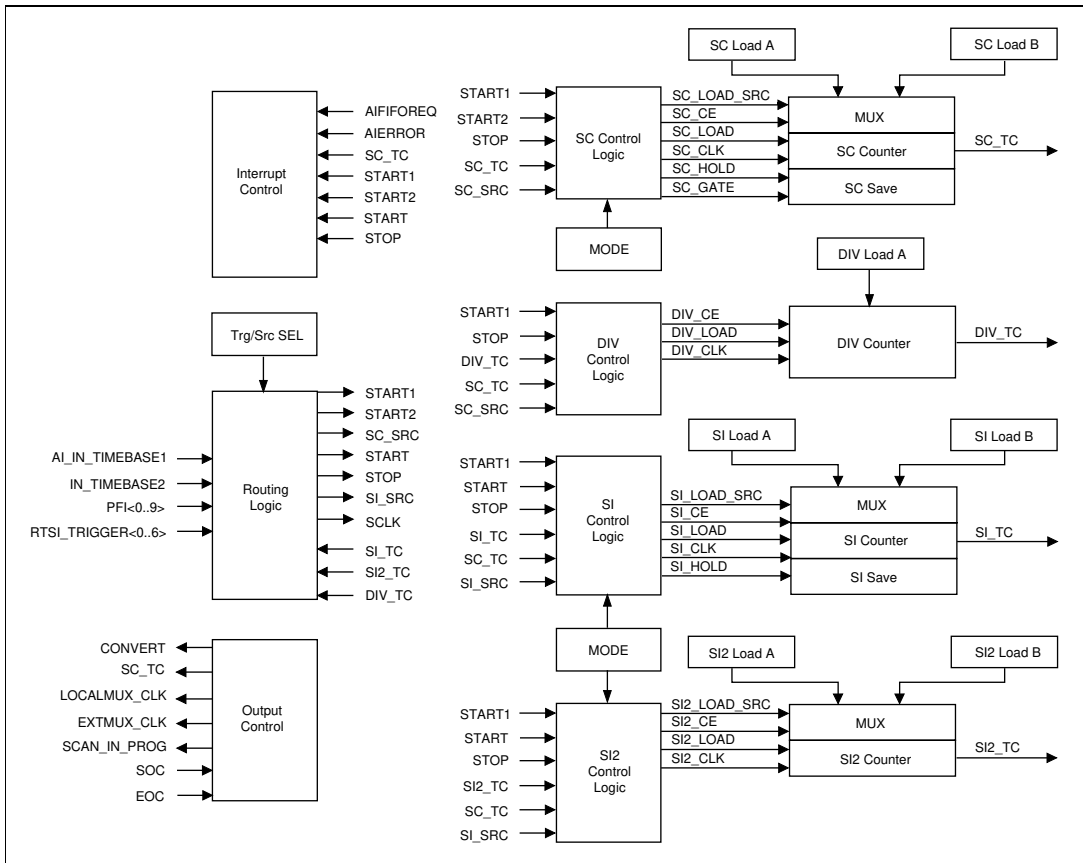

Figure 2-45. AITM Block Diagram

2.8.1 Internal Signals and Operation

Table 2-9 describes the internal signals shown in Figure 2-44.

Table 2-9. Internal Signals

Signal	Description
AD_START	Output Version of START—The hardware generates this signal by passing the output of the AI_START selector through polarity selection, edge detection, synchronization, and additional circuitry that guarantees that AD_START pulses only when the START is recognized as valid by the internal control circuits.
AD_START1	Output Version of START1—This signal can come from two sources. If AI_Delayed_START1 = 0, the hardware generates AD_START1 by passing the output of the AI_START1 selector through polarity selection and edge detection, but not synchronization. If AI_Delayed_START1 = 1, AD_START1 is the same as ADR_START1. Related bitfields: AI_Delayed_START1.
ADR_START1	Internal START1 Signal without Master/Slave Synchronization—This signal is generated by the hardware by passing the output of the AI_START1 selector through polarity selection, edge detection, and synchronization (synchronized to FSC_SRC), bypassing master/slave synchronization.
ADR_START2	START2 without Master/Slave Synchronization—This signal is generated by the hardware by passing the output of the AI_START2 selector through polarity selection, edge detection and synchronization, bypassing master/slave synchronization.
AD_VSTART2	Output Version of START2—This signal can come from two sources. If AI_Delayed_START2 = 0, then the hardware generates AD_VSTART2 by passing the output of the AI_START2 selector through polarity selection, but not edge detection or synchronization. If AI_Delayed_START2 = 1, then AD_VSTART2 is the same as ADR_START2. Related bitfields: AI_Delayed_START2.
AIERROR	AI Error—This signal indicates that an analog error has occurred.
AIFIFOREQ	AI FIFO Request— This signal generates AIFREQ.
AI_IN_TIMEBASE1	Internal Timebase for the Analog Input Module—This signal can be selected to be the same as IN_TIMEBASE, or it can be IN_TIMEBASE divided by two. Related bitfields: AI_Source_Divide_By_2.

Table 2-9. Internal Signals (Continued)

Signal	Description
AI_OUT_TIMEBASE	AI Output Timebase—This signal times the analog input output circuitry. Related bitfields: AI_Output_Divide_By_2.
DIV_CE	DIV Count Enable—This signal enables and disables the DIV counter. Refer to section 2.8.3.8, <i>DIV Control</i> , for the DIV_CE logic equations.
DIV_CLK	DIV Clock—This signal is the actual clock signal for the DIV counter and the DIV counter control logic. When the counter is not armed, DIV_CLK is derived from the write strobe for AI_Command_1_Register, so that the counter can be loaded using the load command. When the counter is armed, DIV_CLK is the same as SC_SRC. Related bitfields: AI_DIV_Load.
DIV_LOAD	DIV Load—This signal pulses to load the value from the DIV load register into the DIV counter. Related bitfields: AI_DIV_Load.
DIV_TC	Divide-Down Counter TC—When an external multiplexer is used (AI_External_MUX_Present = 1), this signal indicates that the desired number of sample pulses for the current channel in the onboard mux-gain list has been generated, so that LOCALMUX_CLK can be asserted to switch to the next channel. When an external multiplexer is not being used (AI_External_MUX_Present = 0), DIV_TC can be used as an internally generated STOP trigger. Related bitfields: AI_External_MUX_Present.
EXT_DIVTC	External Version of DIV_TC—This signal is provided as a pulse-stretched version of the LOCALMUX_CLK signal for use with an external multiplexer. The hardware generates EXT_DIVTC by synchronizing a delayed version of DIV_TC with an internal version of CONVERT.
EXT_GATE	External Gate—This signal can asynchronously (combinatorially) gate the CONVERT output on a per-scan basis. The final scan in a scan sequence cannot be individually gated off. The hardware generates EXT_GATE by passing the output of the AI_External_Gate selector through a circuit that guarantees that the signal does not interrupt a scan in progress. Related bitfields: AI_External_Gate_Mode, AI_External_Gate_Select, AI_External_Gate_St, AI_Software_Gate.
FSCLK	Fast Sample Clock—This signal is the output of the CONVERT selector, after polarity selection. Related bitfields: AI_CONVERT_Source_Select, AI_CONVERT_Polarity_Select.

Table 2-9. Internal Signals (Continued)

Signal	Description
FSC_SRC	Fast Edge of SC Source—This signal synchronizes signals that arrive asynchronously but need to be retimed by SC_SRC. In the internal CONVERT mode, FSC_SRC is equal to the inactive (falling) edge of SI2_SRC. In the external CONVERT mode, FSC_SRC is equal to FSCLK.
IN_TIMEBASE2	Slow Internal Timebase—This signal is derived from the IN_TIMEBASE signal and is usually configured to be 100 kHz. Related bitfields: Slow_Internal_Time_Divide_By_2, Slow_Internal_Timebase.
SC_CE	SC Count Enable—This signal enables and disables the SC counter. Refer to section 2.8.3.2, <i>SC Control</i> , for the SC_CE logic equations.
SC_CLK	SC Clock—This is the actual clock signal for the SC counter and the SC counter control logic. When the counter is not armed, SC_CLK is derived from the write strobe for AI_Command_1_Register, so that the counter can be loaded using the load command. When the counter is armed, SC_CLK is the same as SC_SRC. Related bitfields: AI_SC_Load.
SC_GATE	SC Counter Gate—This signal is generated by the SC control logic. SC_GATE conditions the external CONVERT so that CONVERT passes through only when the SC counter is enabled to count. It is set by the assertion of START1 when SC_ARM is true and is cleared when the SC counter returns to the WAIT1 state. Related bitfields: AI_SC_Gate_Enable, AI_SC_Gate_St.
SC_HOLD	SC Hold—This signal controls the SC save register. If SC_HOLD = 0, then the SC save register tracks the SC counter output. If SC_HOLD = 1, then the SC save register latches the SC counter output on the next SC_CLK.
SCKG	Sample Clock Gate—In the internal CONVERT mode, SCKG is SI2_TC. In the external CONVERT mode, SCKG is 1.
SCLK	Sample Clock—In the internal CONVERT mode, SCLK is the signal SI2_TC. In the external CONVERT mode, SCLK is the signal FSCLK after it passes through a delay gate. The delay gate is provided so that signals synchronized to FSCLK have sufficient time to settle to a known state before being used by SCLK.

Table 2-9. Internal Signals (Continued)

Signal	Description
SCLKG	Internal Sample Clock—SCLKG is the signal that appears on the CONVERT and PFI2/CONV pins. The hardware generates SCLKG by passing the SCLK signal through pulsewidth and polarity-selection circuitry. If the CONVERT pin is configured for high impedance, this signal will be ground. Related bitfields: AI_CONVERT_Output_Select, AI_CONVERT_Original_Pulse, AI_CONVERT_Pulse_Timebase, AI_CONVERT_Pulse_Width.
SC_LOAD	SC Load—This signal pulses to load the value from the selected SC load register into the SC counter. Related bitfields: AI_SC_Load.
SC_LOAD_SRC	SC Load Source—This signal determines which load register, A or B, the SC counter will use on the next reload. The initial SC load source is set using AI_SC_Initial_Load_Source. The SC control logic updates the load source while the AITM is counting. The current load source depends on the counter state and the selected reload mode. Related bitfields: AI_SC_Initial_Load_Source.
SC_SRC	SC Source—The SC source is the timebase for the SC and DIV counters. In the internal CONVERT mode, SC_SRC is the same signal as SI2_SRC. In the external CONVERT mode, SC_SRC is equal to SCLK. The external trigger and gate inputs, which are not generated synchronous to the SC source outside of the AITM, can and should be synchronized to the SC source inside of the AITM.
SC_START1	START1 Synchronized to SC_SRC—This signal is generated by the hardware by passing ADR_START1 through the master/slave trigger circuitry.
SC_TC	Scan Counter TC—This signal indicates to the counter control logic that the programmed number of scans has been generated.
SI2_CE	SI2 Count Enable—This signal enables and disables the SI2 counter. Refer to section 2.8.3.6, <i>SI2 Control</i> , for the SI2_CE logic equations.
SI2_CLK	SI2 Clock—This signal is the actual clock for the SI2 counter and the SI2 control logic. When the counter is not armed, SI2_CLK is derived from the write strobe for AI_Command_1_Register, so that the counter can be loaded using the load command. When the counter is armed, SI2_CLK is the same as SI2_SRC. Related bitfields: AI_SI2_Load.
SI2_LOAD	SI2 Load—This signal pulses to load the value from the selected SI2 load register into the SI2 counter. Related bitfields: AI_SI2_Load.

Table 2-9. Internal Signals (Continued)

Signal	Description
SI2_LOAD_SRC	SI2 Load Source—This signal determines which load register, A or B, the SI2 counter will use on the next reload. The initial SI2 load source is set using AI_SI2_Initial_Load_Source. The SI2 control logic updates the load source while the DAQ-STC is counting. The current load source depends on the counter state and the selected reload mode. Related bitfields: AI_SI2_Initial_Load_Source.
SI2_SRC	SI2 Source—This signal is the timebase for the SI2 counter. It is equal to either SI_SRC or AI_IN_TIMEBASE1. Related bitfields: AI_SI2_Source_Select.
SI2_TC	SI2 TC—This signal is the SCLK signal when internal CONVERT is selected.
SI_CE	SI Count Enable—This signal enables and disables the SI counter. Refer to section 2.8.3.4, <i>SI Control</i> , for the SI_CE logic equations.
SI_CLK	SI Clock—This is the actual clock for the SI counter and the SI control logic. When the counter is not armed, SI_CLK is derived from the write strobe for AI_Command_1_Register, so that the counter can be loaded using the load command. When the counter is armed, SI_CLK is the same as SI_SRC. Related bitfields: AI_SI_Load.
SI_HOLD	SI Hold—This signal controls the SI save register. If SI_HOLD = 0, then the SI save register tracks the SI counter output. If SI_HOLD = 1, then the SI save register latches the SI counter output on the next SI_CLK.
SI_LOAD	SI Load—This signal pulses to load the value from the selected SI load register into the SI counter. Related bitfields: AI_SI_Load.
SI_LOAD_SRC	SI Load Source—This signal determines which load register, A or B, the SI counter will use on the next reload. The initial SI load source is set using AI_SI_Initial_Load_Source. The SI control logic updates the load source while the DAQ-STC is counting. The current load source depends on the counter state and the selected reload mode. Related bitfields: AI_SI_Initial_Load_Source.
SI_SRC	SI Source—This signal is the timebase for the SI counter. Related bitfields: AI_SI_Source_Select.
SI_START1	START1 Synchronized to SI_SRC—This signal is generated by the hardware by passing the output of the AI_START1 selector through polarity selection, edge detection, and synchronization (synchronized to the falling edge of SI_SRC).

Table 2-9. Internal Signals (Continued)

Signal	Description
SI_TC	Scan Interval TC—This signal is the internal START signal.
START	Start—This signal is used when the AITM is in the start/stop mode (AI_Start_Stop = 1). Asserting the START trigger after the timer has been armed and triggered (START1 asserted) starts CONVERT generation. If an internal CONVERT is used, the START trigger starts the SI2 counter. If an external CONVERT is used, the START trigger sets the STST_GATE to allow the CONVERTs to pass. The START signal is software selectable from either polarity of the programmable function inputs, SI_TC, and software strobe. It can be programmed to be level or edge sensitive and can be synchronized to FSC_SRC. Related bitfields: AI_START_Select, AI_START_Pulse, AI_START_Edge, AI_START_Sync.
START1	Start 1—This signal is the start trigger signal for the SC, SI, SI2, and DIV counters. START1 is software selectable from either polarity of the programmable function inputs and software strobe. It can be programmed to be edge or level sensitive and can be synchronized to FSC_SRC. Related bitfields: AI_START1_Select, AI_START1_Pulse, AI_START1_Edge, AI_START1_Sync.
START2	Start 2—This signal is the stop trigger used by the SC counter in the pretrigger mode. START2 is software selectable from either polarity of the programmable function inputs and software strobe. It can be programmed to be edge or level sensitive and can be synchronized to FSC_SRC. START2 is selected using AI_START2_Select. Related bitfields: AI_START2_Select, AI_START2_Pulse, AI_START2_Edge, AI_START2_Sync.

Table 2-9. Internal Signals (Continued)

Signal	Description
STOP	Stop—This signal performs two functions. In the start/stop mode, it halts CONVERT generation until the next START. This is accomplished by stopping the SI2 counter at the next sample pulse if an internal CONVERT is used or by clearing the STST_GATE at the next sample pulse if an external CONVERT is used. The STOP signal also serves as an end of scan (last channel) signal and is used by the SC counter to count scans. Related bitfields: AI_STOP_Select, AI_STOP_Pulse, AI_STOP_Edge, AI_STOP_Sync.
STST_GATE	Start/Stop Gate—This signal is used for conditioning the external CONVERT so that CONVERT passes through only between the assertion of START and the assertion of STOP. STST_GATE is set by the assertion of START after the SC counter has been armed and triggered and is cleared by the assertion of STOP or when the SC counter returns to the WAIT1 state. Related bitfields: AI_Start_Stop_Gate_Enable, AI_Start_Stop_Gate_St.

2.8.2 Trigger Selection and Conditioning

The signal routing block selects the counter clocks, trigger signals, and gate signals from the default timebases (AI_IN_TIMEBASE1 and IN_TIMEBASE2), internal counter outputs, software strobes, and the programmable function timing inputs. The routing logic for the SI_SRC and SCLK signals is a 20-to-1 multiplexer followed by an exclusive OR gate for polarity selection. The routing logic for the trigger signals START and STOP has additional controls for edge detection and synchronization as shown in Figure 2-46.

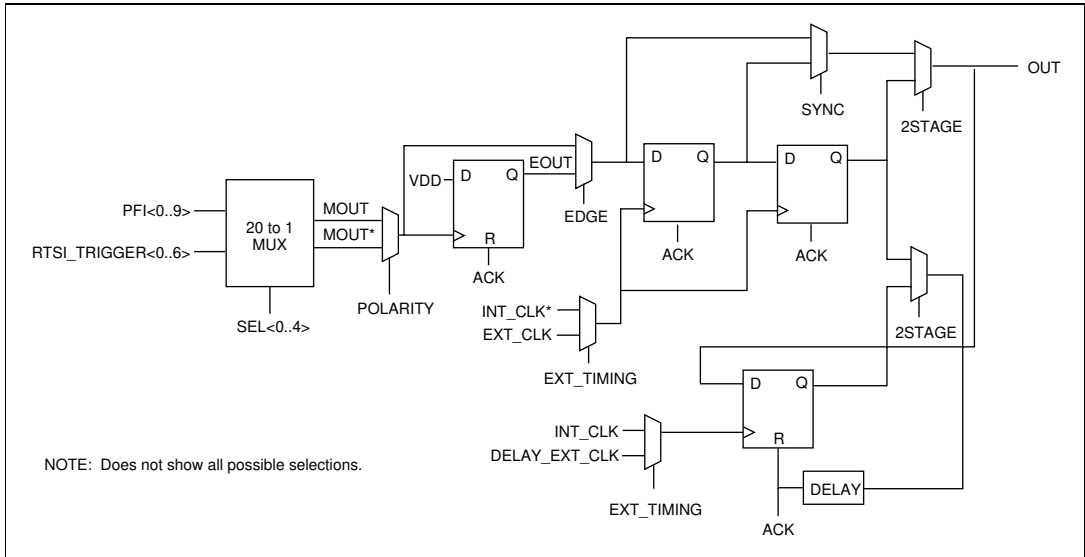

Figure 2-46. START and STOP Routing Logic

Figure 2-47 depicts the control for START1 and START2.

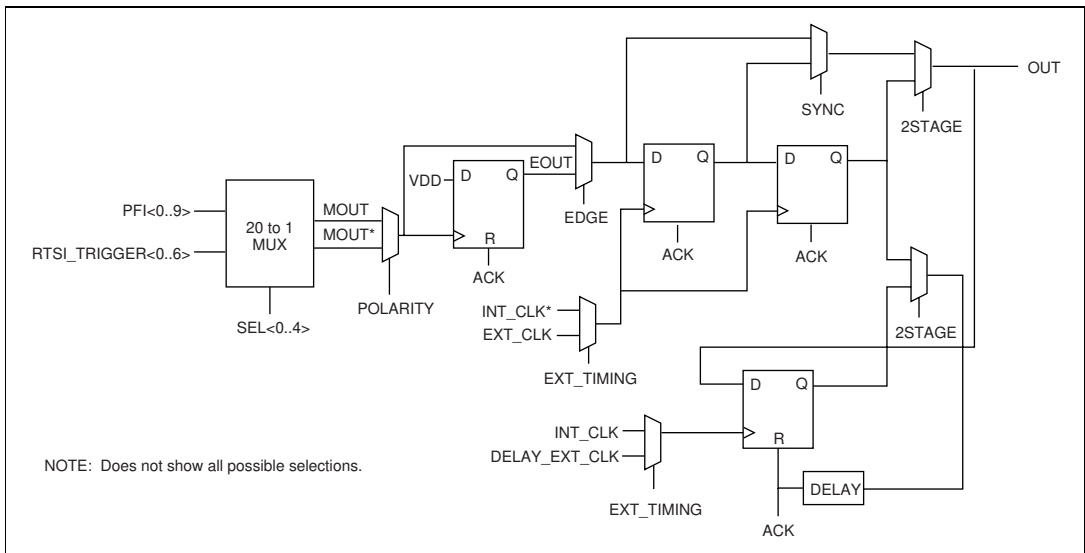

Figure 2-47. START1 and START2 Routing Logic

Figure 2-48 depicts the control for EXT_GATE.

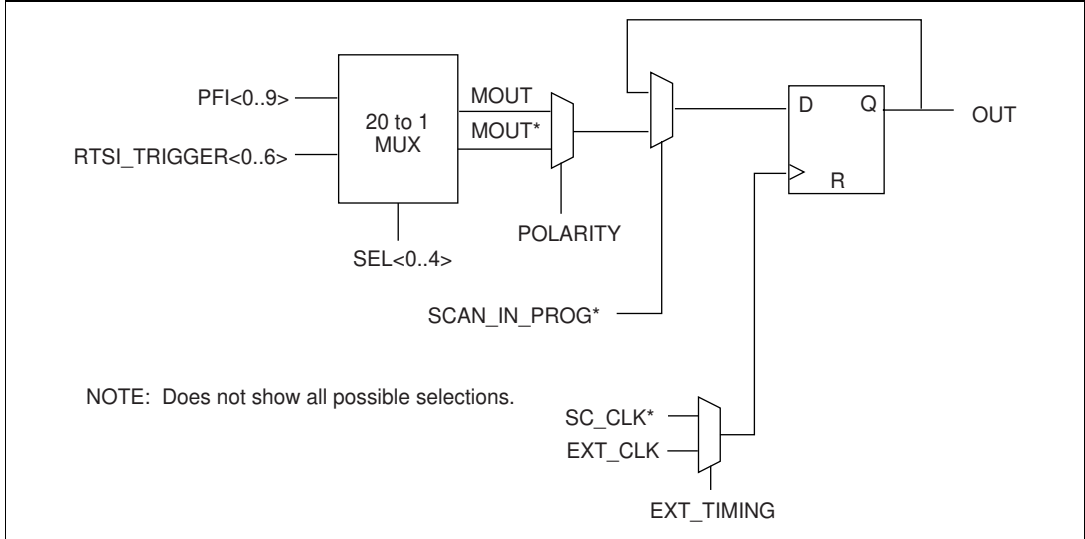

Figure 2-48. EXT_GATE Routing Logic

Table 2-10 summarizes the selections available for each of the trigger signals through the PFI selector.

Table 2-10. PFI Selectors

MUX	0	1–10	11–17	18	19	31
AI_START1_Source	SW	PFI<0..9>	RTSI<0..6>	GOUT0	—	GND
AI_START2_Source	SW	PFI<0..9>	RTSI<0..6>	—	—	GND
AI_SI_Source	AI_TB1	PFI<0..9>	RTSI<0..6>	—	TB2	GND
AI_CONVERT_Source	SI2_TC	PFI<0..9>	RTSI<0..6>	—	GOUT0	GND
AI_START_Source	SI_TC	PFI<0..9>	RTSI<0..6>	SW	GOUT0	GND
AI_STOP_Source	DIV_TC, SW	PFI<0..9>	RTSI<0..6>	SI2_TC	AI_STP	GND
AI_External_Gate	—	PFI<0..9>	RTSI<0..6>	—	—	GND
Key:						
AI_STP	The input AI_STOP_IN					
AI_TB1	The internal analog input signal AI_IN_TIMEBASE1					
GOUT0	The G_OUT signal from general-purpose counter 0					
SW	Software strobe					
TB2	The internal signal IN_TIMEBASE2					



Note *When the analog trigger circuit is enabled, the analog trigger signal takes over the PF10 slot in the PF1 selectors.*

2.8.2.1 Using Edge Detection

Use edge detection whenever a clock period pulse of 1 is required but the pulsewidth of the trigger signal cannot be guaranteed. Internally generated triggers are automatically the correct width and need not be edge detected. Software strobes do not have the correct width and should always be edge detected. Edge detection of external signals can usually be performed without affecting the circuit operation.

2.8.2.2 Using Synchronization

Use synchronization whenever the trigger-to-clock timing relationship cannot be guaranteed. Internally generated triggers automatically have the correct timing and need not be synchronized. Software strobes do not have the correct timing and should always be synchronized. Synchronization of external signals results in a one-half cycle synchronization delay.

2.8.2.3 Trigger Signals

START1 initiates an interval scanning operation in the pretrigger and posttrigger modes. AI_START1_Sync, AI_START1_Edge and AI_START1_Polarity are the options for selection of START1 synchronization, edge detection, and polarity. START1 is always external and should be edge detected and synchronized unless it is sourced from another DAQ-STC operating from the same source clock and timing can be guaranteed. START1 is used by all counters and is, therefore, synchronized to both SI_SRC and SC_SRC.

START2 initiates the final scan sequence in the pretrigger mode. AI_START2_Sync, AI_START2_Edge and AI_START2_Polarity are the options for selection of START2 synchronization, edge detection, and polarity. START2 is always external and should be edge detected and synchronized unless it is sourced from another DAQ-STC operating from the same source clock and timing can be guaranteed. START2 is used by the SC counter and is therefore synchronized to SC_SRC.

START initiates a predetermined number of conversion pulses during each scan. When internally generated, START is the SI_TC signal. AI_START_Sync, AI_START_Edge, and AI_START_Polarity are the options for selection of START synchronization, edge detection, and polarity. When externally generated, START should be edge detected and synchronized unless it is sourced from another DAQ-STC operating from the same source clock and timing can be guaranteed. START is used by the SC counter and is, therefore, synchronized to SC_SRC.

STOP is used to end the conversion pulse sequence when the number of channels has been reached. For low-end applications, the DIV counter generates STOP. For high-end applications, the configuration FIFO provides STOP. AI_STOP_Sync, AI_STOP_Edge, and AI_STOP_Polarity are the options for selection of STOP synchronization, edge detection, and polarity. When externally generated, STOP should be synchronized unless it is sourced from another DAQ-STC operating from the same source clock and timing can be guaranteed. STOP is used by the SC counter and is, therefore, synchronized to SC_SRC.

2.8.3 Analog Input Counters

The SI counter is a 24-bit binary down counter that generates scan interval timing (START pulses) when you select internal START. When you select external START, the SI counter can enforce a minimum delay from START1 to the first recognized START. The SI2 counter is a 16-bit binary down counter that generates sample interval timing (CONVERT pulses) when you select internal CONVERT. When you select external CONVERT, the SI2 counter is unused. The SC counter is a 24-bit binary down counter that counts scans when a predetermined number of scans is to be generated.

The SI counter alternate first-period reload modes provide a retriggerable method to obtain a delay between START1 and START that is different from the scan interval. Software stores the scan interval in SI load register B and the delay from START1 in SI load register A. The SI counter initially loads from load register A, and then the SI load source is set to B. During the acquisition, the SI counter reloads from load register B except for the last reload, when it reloads from SI load register A.

Similarly, the SI2 counter alternate first period reload modes provide a retriggerable method for obtaining a delay between START and CONVERT, which is different from the sample interval. Software stores the sample interval in SI2 load register B and the delay from START in SI2 load register A. The SI2 counter initially loads from load register A, and then the SI2 load source is set to B. During each scan, the SI2 counter reloads from load register B except for the last reload, when it reloads from SI2 load register A.

The DIV counter is a 16-bit binary down counter that divides down the configuration FIFO clock (LOCALMUX_CLK) when an external multiplexer is used. It can also be used to provide an internally generated STOP trigger.

Each of these counters (except DIV) has dual-load registers so that their reload value can be changed while they are counting. The SI and SC counters each have a save register that can be used to hold the contents of the counter.

The SI, SI2, SC, and DIV counters each have their own control block. The counter control blocks are synchronous control circuits that use the counter mode information, trigger and gate signals, and state of the counter to generate the count enable and load control signals. The state diagrams for the control circuits are discussed below.

2.8.3.1 SC Counter

The SC counter is a 24-bit down counter with dual-load registers and output save latch. The SC counter is used to count scans. When you select internal CONVERT, the SC counter source is equal to SI_SRC. In this mode the SC counter increments on SI2_TC AND STOP. When you select external CONVERT, the SC counter source is SCLK. In this mode the SC counter increments on every STOP.

The counter load registers are directly accessible (in write mode) from the register map. If the counter is disarmed, AI_SC_Load will load the counter with the value from the selected load register. The AI_SC_Write_Switch option allows the load register writes to be directed to the inactive load register.

During normal operation, the SC counter will synchronously reload from the selected load register following SC_TC. Several options allow the SC counter to change the selected load register under various conditions. The options are to switch load registers on every SC_TC (AI_SC_Reload_Mode) and to switch load registers on the next SC_TC (AI_SC_Switch_Load_On_TC). The SC control circuit (discussed below) generates the count enable signals.

The SC save register latch signal asserts after a rising and then a falling edge of SC_SRC following a 1 being written to AI_SC_Save. The SC save register latch signal deasserts after a rising and then a falling edge of SC_SRC following a 0 being written to AI_SC_Save.

2.8.3.2 SC Control

The SC counter is controlled by a circuit whose state transitions are shown in Figure 2-49. The SC counter control circuit has four states: WAIT1, PCNT, WAIT2, and CNT. The bitfield AI_Pre_Trigger determines the sequence of the control circuit. When AI_Pre_Trigger is low, the counter simply counts until the scan requirement is fulfilled. When AI_Pre_Trigger is high, the counter first satisfies the pretrigger scan requirement before fulfilling the posttrigger scan requirement.

On power up, the counter begins in WAIT1 and remains there until the counter is armed and a START1 pulse is received. If AI_Pre_Trigger is low, the counter moves directly to the CNT state. If AI_Pre_Trigger is high, the counter moves to PCNT and remains counting until reaching SC_TC (fulfilling the pretrigger requirement). The control circuit then transitions to WAIT2 to wait for the START2 signal. When START2 is received, the control circuit transitions to CNT, and the counter continues to count scans until SC_TC. When the counting is complete, SC_TC causes the control circuit to return to WAIT1.

The internal signal SCKG affects the count operation of the SC counter. When the internal timebase is selected for the SC source (AI_CONVERT_Source_Select is set to 0), SCKG becomes the sample interval counter TC signal (SI2_TC). If a different source is selected for the SC counter (AI_CONVERT_Source_Select is not set to 0) SCKG = 1.

The SC load signal (SC_LOAD) enables the SC counter to reload from the selected load register on the next clock. SC_LOAD asserts when SC_TC is reached and TRANS is high or it is asserted by software (AI_SC_Load).

The SC count enable signal (SC_CE) allows the SI counter to count. SC_CE asserts on any transition originating from or terminating at either of the PCNT or CNT states, provided that the SC counter is armed (AI_SC_Arm), TRANS is high, and EXT_GATE is enabled.

The SC disarm signal (SC_DISARM) clears the AI_SC_Arm bit in the register map. SC_DISARM asserts on the transition from the CNT state to the WAIT1 state when either AI_End_On_End_Of_Scan, AI_End_On_SC_TC, or AI_Trigger_Once is high.

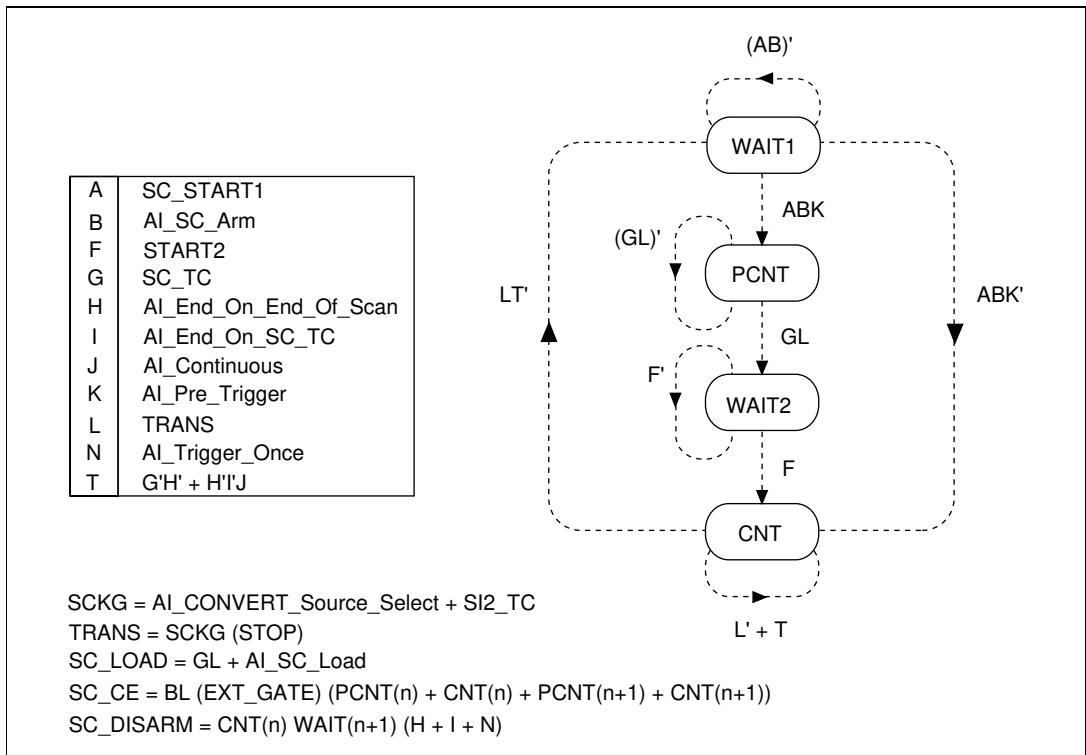

Figure 2-49. SC Control Circuit State Transitions

2.8.3.3 SI Counter

The SI counter is a 24-bit down counter with dual-load registers. The SI counter counts the interval between internal STARTs, as well as the delay from the initial trigger to the start of the first internal or external START. The bitfield `AI_SI_Source_Polarity` selects the polarity of the source clock (`SI_SRC`). The counter load registers are directly accessible in write mode from the register map. If the counter is disarmed, `AI_SI_Load` will load the counter with the value from the selected load register. The `AI_SI_Write_Switch` option allows the load register writes to be directed to the inactive load register.

During normal operation, the SI counter will synchronously reload from the selected load register following `SI_TC`. Several options exist (`AI_SI_Reload_Mode`, `AI_SI_Switch_Load_On_END`, `AI_SI_Switch_Load_On_STOP`, and `AI_SI_Switch_Load_On_TC`) for the SI counter to change the selected load register under various conditions. The options are: alternate load registers once after each STOP; switch load registers on every STOP; alternate load registers once after each `SC_TC`; switch load registers on every `SC_TC`; switch load registers on the next `SC_TC`; switch load registers on the next STOP; switch load registers on the next `SI_TC`.

The term *alternate load registers* refers to the action of having one load from the secondary load register and the remaining loads from the primary load register. The SI control circuit generates the count enable signals.

2.8.3.4 SI Control

The SI counter is controlled by a circuit whose state transitions are shown in Figure 2-50. The SI counter control circuit has two states: `WAIT1` and `CNT1`. On power up, the control circuit begins in state `WAIT1` and remains there until the counter is armed and a `START1` pulse is received. When these two events occur, the counter moves to the `CNT1` state and begins generating `START` signals (internal `START`) or begins counting the `START` holdoff (external `START`). On `SC_TC`, the required number of `START`s has been generated and the counter returns to the `WAIT1` state.

The SI load signal (`SI_LOAD`) enables the SI counter to reload from the selected load register on the next clock. `SI_LOAD` is asserted when `SI_TC` is reached or is asserted by software (`AI_SI_Load`).

The SI count enable signal (`SI_CE`) allows the SI counter to count. `SI_CE` asserts on any transition terminating at either the `CNT1` or `CNT2` state, provided that the SI counter is armed (`AI_SI_Arm`).

The SI disarm signal (`SI_DISARM`) clears the `AI_SI_Arm` bit in the register map. `SI_DISARM` asserts on the transition from the `CNT1` to the `WAIT1` state when `AI_End_On_End_Of_Scan`, `AI_End_On_SC_TC`, or `AI_Trigger_Once` is high.

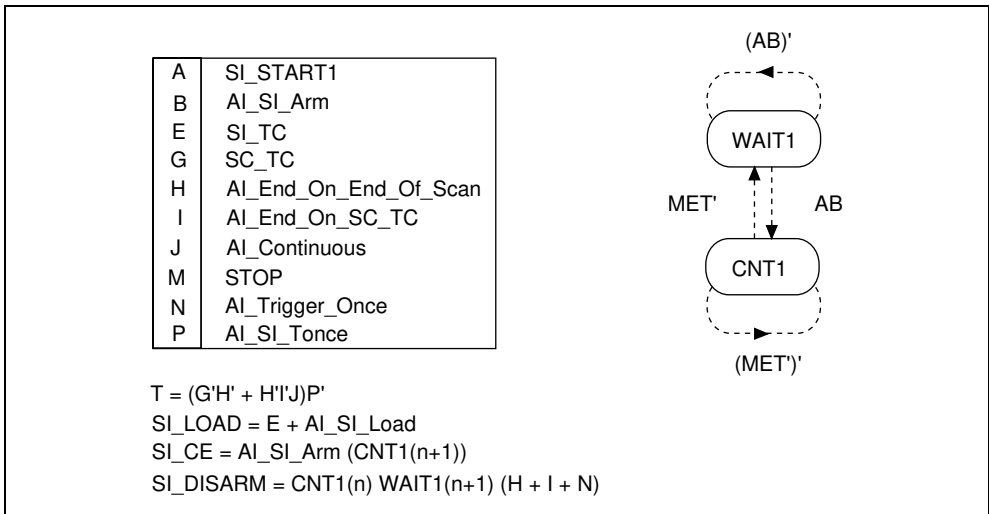

Figure 2-50. SI Control Circuit State Transitions

2.8.3.5 SI2 Counter

The SI2 counter is a 16-bit down counter with dual-load registers. The SI2 counter counts the interval between samples, as well as the delay from the START signal to the first sample pulse. The SI2 counter uses the same clock that is selected for the SI counter (SI_SRC) or AI_IN_TIMEBASE1. The counter load registers are directly accessible from the register map. If the counter is disarmed, AI_SI2_Load will load the counter with the value from the selected load register.

During normal operation, the SI2 counter will synchronously reload from the selected load register following SI2_TC. The AI_SI2_Reload_Mode option allows the SI2 counter to alternate load registers once after every STOP. The SI2 control circuit generates the count enable signals.

2.8.3.6 SI2 Control

The SI2 counter is controlled by a circuit whose state transitions are shown in Figure 2-51. The SI2 counter control circuit has three states: WAIT1, WAIT2 and CNT. On power up, the counter begins in state WAIT1 and remains there until the counter is armed and a START1 pulse is received. When these two events occur, the counter transitions to state WAIT2 to wait for START to be asserted. Once START is received, the counter transitions to state CNT and begins counting. When STOP is received, the counter returns to the WAIT2 state to wait for another START.

The SI2 load signal (SI2_LOAD) enables the SI2 counter to reload from the selected load register on the next clock. SI2_LOAD is asserted when SI2_TC is reached or is asserted by software.

The SI2 count enable signal (SI2_CE) allows the SI2 counter to count. SI2_CE is asserted on any transition terminating at the CNT state, provided that the SI2 counter is armed.

The SI2 disarm signal (SI2_DISARM) clears the AI_SI2_Arm bit in the register map. SI2_DISARM is asserted on the transition from the CNT state to the WAIT1 state when AI_End_On_End_Of_Scan, AI_End_On_SC_TC, or AI_Trigger_Once is high.

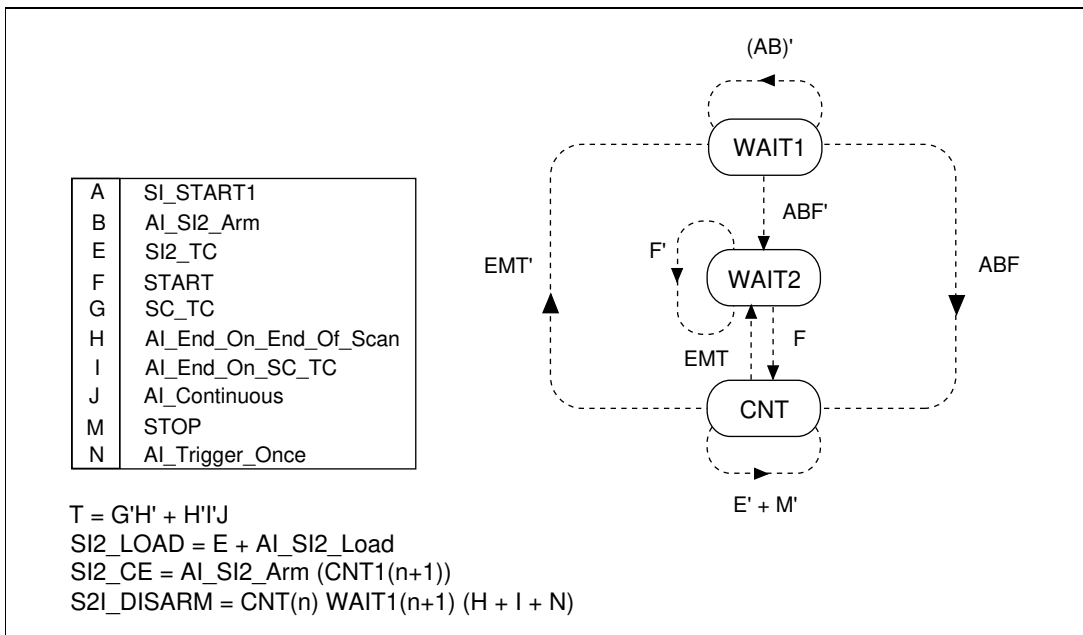

Figure 2-51. SI2 Control Circuit State Transitions

2.8.3.7 DIV Counter

The DIV counter is a 16-bit down counter. The DIV counter typically divides down LOCALMUX_CLK when an external multiplexer is used. The DIV counter uses the same clock that is selected for the SC counter (SC_SRC). The counter load register is directly accessible from the register map. If the counter is disarmed, AI_DIV_Load will load the counter with the value from the load register. During normal operation, the DIV counter will synchronously reload from the load register following DIV_TC. The DIV control circuit generates the count enable signals.

2.8.3.8 DIV Control

The DIV counter is controlled by a circuit whose state transitions are shown in Figure 2-52. The DIV counter control circuit has two states: WAIT and CNT. On power up, the control circuit begins in state WAIT and remains there until the counter is armed and a START1 pulse is received. When these two events occur, the counter moves to the CNT state and begins counting. On DIV_TC, the counter either remains counting or returns to the WAIT state depending on the signals STOP, SCKG, AI_End_On_End_Of_Scan, AI_End_On_SC_TC, SC_TC, AI_Continuous and AI_Trigger_Once. For continuous acquisition modes, the DIV counter control circuit can return to state WAIT based on the software strobes AI_END1 and AI_END2.

The internal signal SCKG controls the count operation of the DIV counter. When the internal timebase is selected for the SC source (AI_CONVERT_Source_Select is set to 0), SCKG becomes the sample interval counter TC signal (SI2_TC). In this mode, DIV counts samples. If a different source is selected for the SC counter (AI_CONVERT_Source_Select is not set to 0) then SCKG = 1. In this mode, DIV counts edges on the source clock.

The DIV load signal (DIV_LOAD) enables the DIV counter to reload from the selected load register on the next clock. DIV_LOAD is asserted when DIV_TC is reached and SCKG is high, or is asserted by software (AI_DIV_Load).

The DIV count enable signal (DIV_CE) allows the DIV counter to count. DIV_CE asserts on any transition originating from or terminating at the CNT state, provided the DIV counter is armed (AI_DIV_Arm) and SCKG is high.

The DIV disarm signal (DIV_DISARM) clears the AI_DIV_Arm bit in the register map. DIV_DISARM asserts on the transition from the CNT state to the WAIT state when AI_End_On_End_Of_Scan, AI_End_On_SC_TC, or AI_Trigger_Once is high.

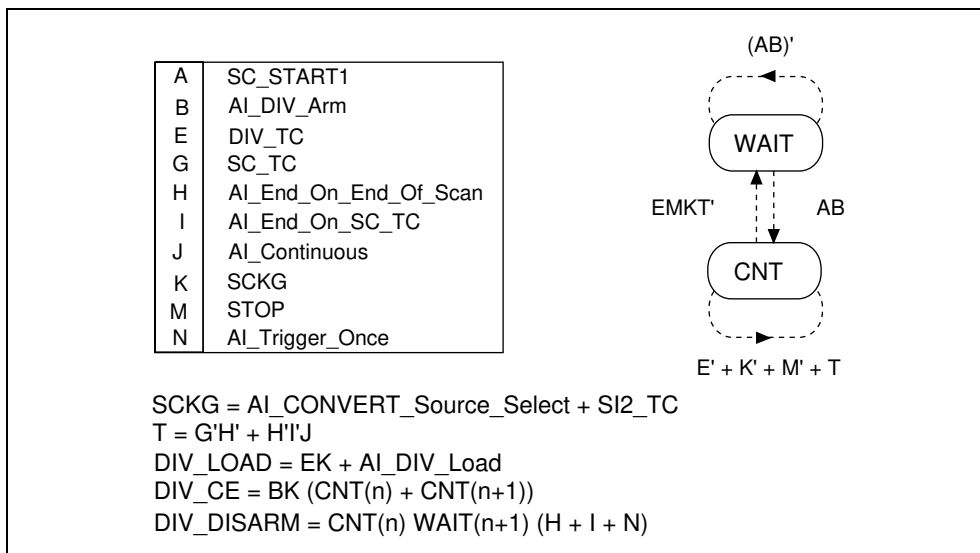

Figure 2-52. DIV Control Circuit State Transitions

2.8.4 Interrupt Control

The analog input contains the hardware necessary for generating software interrupts based on several conditions. The interrupt programming is accomplished using the `Interrupt_A_Enable_Register` and the `Second_Irq_A_Enable_Register`. Interrupts remain active until cleared by software. Software can program the interrupts to occur under the following conditions: overflow or overrun error, START, STOP, START1, START2, SC_TC, and FIFO condition.

All of the interrupts work independently with the exception of the STOP interrupt. In order for the STOP interrupt to operate properly, the START interrupt must also be enabled and operating. In addition, the START interrupt must be acknowledged prior to the assertion of the STOP signal in order for STOP to generate an interrupt.

When the SC_TC interrupt is enabled, an interrupt is generated on every SC_TC falling edge, unless the pretrigger acquisition mode is selected. In the pretrigger acquisition mode, the interrupt is generated only on SC_TC falling edges that occur after the pretrigger count requirement has been satisfied. That is, in the pretrigger acquisition mode, the first SC_TC does not generate an interrupt.

Table 2-11 summarizes the analog input interrupts and lists the condition that causes the interrupt.

Table 2-11. Analog Input Interrupts

Interrupt	Condition
Error interrupt	Interrupt generated on the detection of a overrun or overflow error condition.
START interrupt	Interrupts are generated on valid START triggers received by the DAQ-STC. A valid START trigger is one that is received while the SC counter is enabled to count. The actual interrupt signal appears on the active edge of SC_CLK.
STOP interrupt	Interrupts are generated on valid STOP triggers received by the DAQ-STC. A valid STOP trigger is one that is received after a valid START and while counting is enabled on the SC counter. After a valid START, the actual interrupt signal appears on the active edge of SC_CLK. Note that this interrupt must be used in conjunction with the START interrupt.
START1 interrupt	Interrupts are generated on valid START1 triggers received by the DAQ-STC. A valid START1 trigger is one that is received while the SC counter is armed and in the WAIT1 state. The actual interrupt signal appears on the active edge of SC_CLK.
START2 interrupt	Interrupts are generated on valid START2 triggers received by the DAQ-STC. A valid START2 trigger is one that is received while the SC counter is in the WAIT2 state. The actual interrupt signal appears on the active edge of SC_CLK.
SC_TC interrupt	Interrupts are generated on every SC_TC falling edge unless the pretrigger acquisition mode is selected. In the pretrigger acquisition mode, the first SC_TC falling edge does not generate an interrupt, but subsequent SC_TC falling edges do.
FIFO interrupt	Interrupt generated on the FIFO condition indicated by AI_FIFO_Mode.

2.8.5 Error Detection

The DAQ-STC detects three analog input errors—overrun, overflow, and SC_TC error.

2.8.5.1 Overrun Error

An overrun error occurs when the ADC interval is not long enough to complete a conversion. In hardware, this is detected when a CONVERT pulse occurs before the last conversion is completed. Two modes are available for the overrun-error detection interval, as selected by AI_Overrun_Mode. In mode 0, the error-detection interval starts on SOC and ends on EOC. In mode 1, the error-detection interval starts on SOC and ends on the trailing edge of SHIFTIN.

2.8.5.2 Overflow Error

An overflow error occurs when an attempt is made to write the ADC result to a full AI data FIFO. In hardware, this is detected when a SHIFTIN pulse occurs while the AI FIFO full flag (AIFFF) is active. This can happen when the FIFO read rate does not keep pace with the FIFO write rate. If the overflow error occurs, at least one point of data has been lost.

2.8.5.3 SC_TC Error

During staged analog input, the software loads the parameters for each posttrigger acquisition sequence during the previous acquisition sequence. The software must complete this programming operation before the end of the current acquisition sequence. An SC_TC error occurs when the parameters for the next sequence are not written in the allotted time. The error-detection circuit is armed on each SC_TC. If a software clear (AI_SC_TC_Interrupt_Ack) does not occur before the next SC_TC, the error-detection circuit latches an error condition.

2.8.6 Nominal Signal Pulsewidths

Table 2-12 lists the nominal pulsewidths for the signals associated with analog input. Note that only the CONVERT signal can use either the source or output clocks; all of the others must use the indicated clock source. These are only the nominal pulsewidths; the actual synchronization edges and propagation delays are detailed in section. [2.7, Timing Diagrams](#).

Table 2-12. Analog Input Nominal Signal Widths

Signal	Source Clock	Output Clock
CONVERT	1	1, 2
SHIFTIN	—	1, 2
SC_TC	1	—
LOCALMUX_CLK	—	(1 or 2) to SOC
EXTMUX_CLK	—	LocalMuxClk or 5
SCAN_IN_PROG	From START to last SOC	—
EXTSTROBE	Eight cycles of 1.2 μ s or 10 μ s, software toggle	—
LOCALMUX_FFRT	—	1

Analog Output Timing/Control

3.1 Overview

This chapter describes the analog output timing/control module (AOTM), which generates timing for the DACs and controls signals for the associated circuitry, such as the data FIFO buffers. Two independent update groups, primary and secondary, are supported. The primary update group is fully supported by hardware and the secondary update group is supported through interrupt software.

The primary update group contains a 24-bit update interval counter (UI), a 24-bit update counter (UC), a 24-bit buffer repetition counter (BC), and a 4-bit channel address counter (CHADDR). The UI counter determines the update interval. The UC counter counts the primary UPDATE pulses, controlling the size of the buffer output. The BC counter controls the number of times a buffer is generated. The CHADDR counter generates successive DAC addresses in multiple-channel update mode. It also controls the number of DAC writes generated in an update cycle.

The secondary update group contains a 16-bit secondary update interval counter (UI2), which generates an independent update interval clock. The secondary update group does not have additional counters such as the update and buffer repetition counters associated with it. Instead, these functions will be carried out by software. The UI2 counter can select either general-purpose counter output as the source clock, and the UI2 counter's toggled output can gate either of the two general-purpose counters.

There are five timing and control signals associated with the analog output. These signals are START1, the update clock (UPDATE), the update interval clock (UI source), the secondary update interval clock (UI2 source), and the secondary external gate. The AOTM contains independent multiplexers and conditioning circuits to derive these timing and control signals from any of 10 PFI signals, seven RTSI trigger signals, or other internal signals.

For more information about devices with which the AOTM can work, read section [1.1.2, Analog Output Application](#) in Chapter 1, [Introduction](#).

3.1.1 Programming the AOTM

To program the AOTM module of the DAQ-STC, read section *Analog Output Application*, and read this chapter through section 3.6, *Programming Information*.

As you read section 3.6, *Programming Information*, you will need to refer to section 3.7, *Timing Diagrams*. You will also need to consult the register-level programmer manual for the device containing the DAQ-STC. You should not have to read section 3.8, *Detailed Description*.

3.2 Features

The AOTM has the following features:

- Update interval timing
 - 24-bit update interval down counter
 - Maximum update rate of 1.6 MHz on two output channels
 - Maximum frequency of 20 MHz yields 50 ns resolution with a maximum interval of 0.83 s
 - Divide-by-two timebase yields 100 ns resolution with a maximum interval of 1.67 s
 - Divide-by-200 timebase yields 10 μ s resolution with a maximum interval of 167 s
- Secondary update interval
 - 16-bit counter with independent timebase selection for a secondary update group that is primarily interrupt driven
- External timing available for the following signals:
 - START1
 - UPDATE
 - UI source
 - UI2 source
 - Secondary external gate
- Bidirectional external timing pins
 - Input clock sources and triggers from PFI<0..9> and RTSI_TRIGGER<0..6>
 - Output the internally generated update and trigger signals to the board
- Programmable polarities for external UPDATE and external START1 input
- Synchronously change the update interval

- Update count
 - 24-bit update down counter
 - Trigger up to 2^{24} pulses or generate updates continuously
- Buffer repetition count
 - 24-bit buffer repetition down counter
- Mute buffers
 - Programmable delays between waveforms
- Number of channels
 - Up to 16 channels
 - Higher channel count possible with external hardware
- Trigger modes
 - Hardware and software triggering
 - Support for analog triggering
- Delayed trigger
 - Interval counters have alternate first period capability for retriggerable delay from trigger
 - Minimum delay of 1 update interval clock
 - Maximum delay of 2^{24} update interval clocks
- Gating
 - Hardware and software gating
- Simplified interface to data FIFO
 - Supports local buffer mode
- Error detection
 - Underflow error-detection flag for internal or external timing on both update groups
 - Additional error detection for double-buffered parameter-change operations
- Bus interface support
 - Interrupts based on update, triggers, error conditions, and FIFO flags
 - FIFO-flag-based request signal to simplify DMA or interrupt request logic
 - Bus cycle extension for D/A bus contention case and slow DAC write case

3.3 Simplified Model

The AOTM module contains the hardware necessary to generate timing and control signals for the DAC on an MIO board. Figure 3-1 shows a simplified model of the AOTM module.

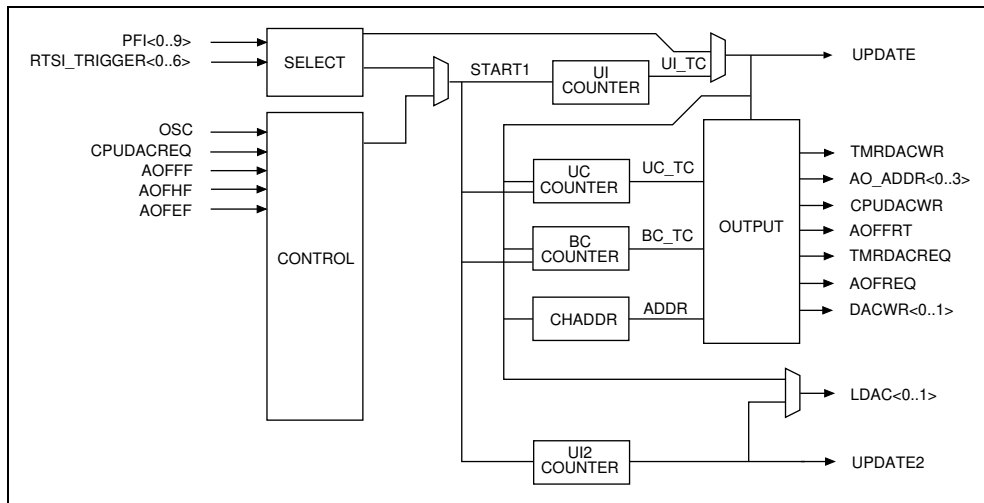

Figure 3-1. AOTM Simplified Mode

One of the primary AOTM features is that a wide variety of timing signals can be selected as timing and control sources. The simplified model depicts this as a select circuit, which chooses between the 10 PFI signals PFI<0..9> and the seven RTSI signals RTSI_TRIGGER<0..6>. Many of the signals required for D/A conversion can come from external sources routed through the selector. The DAQ-STC also has the ability to generate the timing sources internally.

The primary analog output timing signal is the UPDATE pulse. The simplified model shows that the source for the UPDATE pulse may come from the UI counter (internal UPDATE source) or the select circuit (external UPDATE source).

Using UPDATE as a reference, the output section generates several ancillary signals used on the board. The TMRDACWR output signal (DAQ-STC write to the DAC) toggles repeatedly after each UPDATE, according to the number of analog output channels, to load the DACs with the next data value. The CHADDR counter generates the outputs AO_ADDR<0..3>, which provide the DAC destination address for the data.

The signals CPUDACREQ (CPU request for access to the DAC) and CPUDACWR (CPU write to the DAC) are associated with CPU-driven analog output. The CPU asserts CPUDACREQ to request a write to one of the output channels, and CPUDACWR is the actual write signal. AOFFRT (AO data FIFO retransmit) retransmits the analog output FIFO

contents in the local buffer mode. TMRDACREQ (DAQ-STC data request) indicates that there is no data available for the timer initiated write to the DAC. The signals DACWR<0..1> (DAC write strobe) serve as write strobes for the DACs, combining the timer- and CPU-initiated writes. The signals LDAC<0..1> (DAC Load) serve as DAC updates in the two DAC board case and can be configured to output primary or secondary UPDATE. The AOFREQ (AO data FIFO request) output is used to generate a DMA request based on the analog output FIFO flags AOFEF (AO data FIFO empty flag), AOFHF (AO data FIFO half-full flag), and AOFFF (AO data FIFO full flag).

Sequences of UPDATE pulses are organized into buffers. The value in the UC counter indicates the number of data points contained in each buffer, and the value in the BC counter indicates the number of buffers to be generated.

The UI2 counter realizes an independent secondary analog output function, generating UPDATE2 (secondary update) pulses based on software programming. The START1 trigger signal begins the primary and secondary analog output sequence and may come from a number of different sources, such as PFI, RTSI, software, and the internal signal START1 from the AITM.

3.4 Analog Output Functions

The basic analog output functionality provided by the DAQ-STC is the timing of up to 16 independent double-buffered DACs fed by a single FIFO. Many variations on this basic function are possible. This section provides an overview of the basic analog output functions and indicates some of the likely variations. First, a distinction between DAQ-STC-driven analog output and CPU-driven analog output is made. Next, some of the methods of providing analog output data are described. This is followed by a description of the parameters involved in UPDATE timing and buffer timing. Finally, the external gating function and secondary analog output are described.

3.4.1 Primary Group Analog Output Modes

Two modes of operation are possible with the AOTM: DAQ-STC-driven analog output and CPU-driven analog output. In the DAQ-STC-driven mode, the DAQ-STC generates the timing necessary to move data from memory to the DACs according to the programmed instructions. The programming specifies the number of points to output and, in the internal UPDATE mode, the rate at which to output the points. In the CPU-driven mode, the CPU alone determines when the points are output. In some cases, DAQ-STC-driven and CPU-driven analog output may occur simultaneously on different channels, in which case arbitration is provided by the DAQ-STC.

3.4.1.1 DAQ-STC-Driven Analog Output

In DAQ-STC-driven analog output, the primary output signals are UPDATE, TMRDACWR, and AO_ADDR<0..3>. The UPDATE signal serves to transfer the data to the outputs of all of the DACs simultaneously. Following the UPDATE, the DAQ-STC writes the next data point to each DAC sequentially, using the write pulse TMRDACWR. The AO_ADDR<0..3> signals indicate which DAC is to be the destination of the current write pulse. The TMRDACWR signal actually performs the write, and you should decode the AO_ADDR<0..3> lines to determine which DAC to select.

Figure 3-2 shows two DAQ-STC-driven analog output operations on a board configured for four analog output channels. After each update, the TMRDACWR signal pulses four times to reload the DACs.

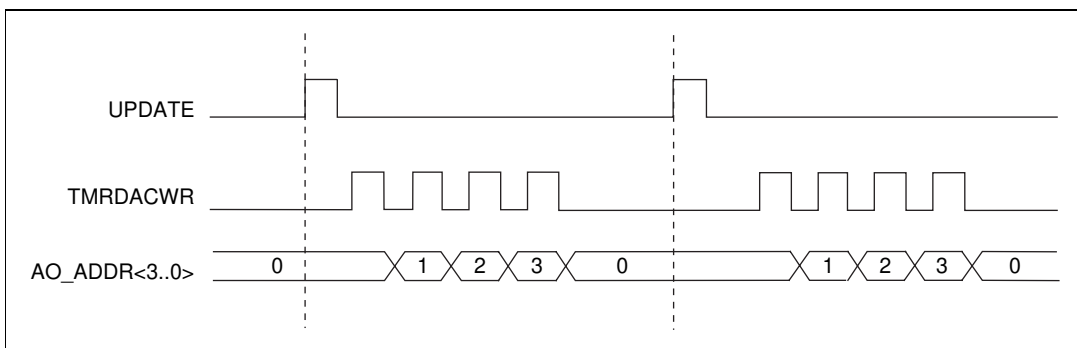

Figure 3-2. DAQ-STC-Driven Analog Output

3.4.1.2 CPU-Driven Analog Output

The DAQ-STC also provides circuitry that allows the CPU to write directly to the output channels. The primary signals for CPU-driven analog output are CPUDACREQ, CHRDY_OUT, and CPUDACWR. The CHRDY_OUT signal is discussed in Chapter 9, Bus Interface. The CPU initiates an analog output by asserting CPUDACREQ and placing the destination address of the DAC write on the CPU bus address lines. The DAQ-STC responds by lowering CHRDY_OUT to extend the current bus cycle. When the hardware is ready, the bus address lines A<0..3> pass through to the AO_ADDR<0..3> lines and the CPUDACWR line pulses to complete the write. CHRDY_OUT is then released to allow the bus cycle to continue. The bus cycle delay signal CHRDY_OUT operates in two software-selectable modes. In the slow interface mode, CHRDY_OUT deasserts until the write to the DAC is complete. In the fast interface mode, CHRDY_OUT deasserts only until the write to the DAC is initiated, maximizing bus bandwidth.

Figure 3-3 shows a sequence of three consecutive CPU-driven analog output operations, one each to the DAC at addresses four, five, and six. In this figure, CHRDY_OUT is held until the write to the DAC is complete (slow interface mode).

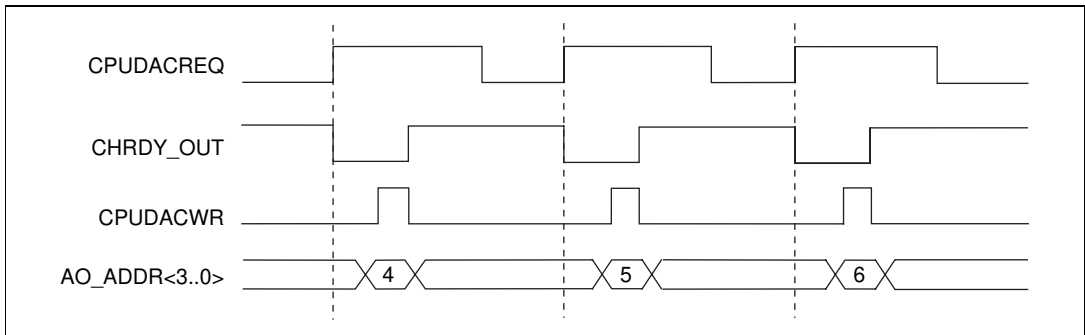

Figure 3-3. CPU-Driven Analog Output

3.4.1.3 DAQ-STC and CPU Conflict

The possibility exists that the CPU and DAQ-STC will both attempt to write to the DACs at the same time. The CPU is given priority over the DAQ-STC, but it can not interrupt a DAQ-STC write cycle in progress. If the DAQ-STC is writing to the DACs, the CPU bus cycle will be extended to the next write slot.

Figure 3-4 shows a DAQ-STC-driven analog output sequence on a board configured with eight channels, interrupted by a CPU-driven analog output to DAC number 9.

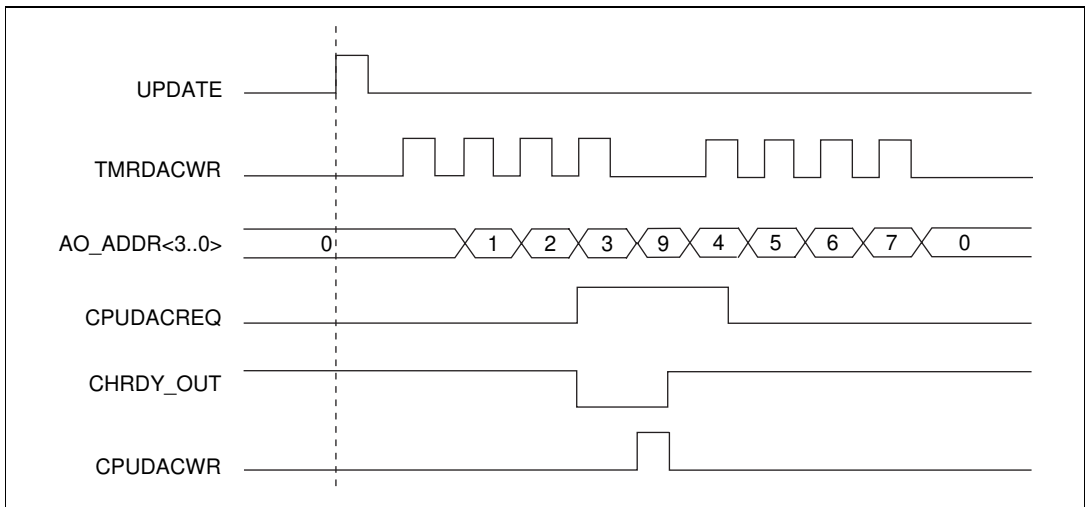

Figure 3-4. DAQ-STC and CPU Conflict

3.4.2 DAC Interface

In addition to TMRDACWR and AO_ADDR<0..3>, the DAQ-STC provides four other pins that can be used to interface to the DACs. The DACWR<0..1> pins serve as DAC write strobes by pulsing on each TMRDACWR pulse and on each CPUDACWR pulse. Two modes are available for the DACWR<0..1> signals—single-DAC mode and dual-DAC mode. The single-DAC mode supports two distinct DACs. In the single-DAC mode, DACWR0 pulses on every write to an even channel and DACWR1 pulses on every write to an odd channel. The dual-DAC mode supports two DACs that are contained in a single package. In the dual-DAC mode, DACWR0 pulses on every write and DACWR1 is not used.

The LDAC<0..1> pins serve as DAC updates when the DACs are configured for double-buffered output. Two update modes are available for the LDAC<0..1> signals: timed update mode and immediate update mode. Select the timed update mode if you want the outputs of all of the DACs to update simultaneously. Select the immediate update mode if you want the output of each DAC to update immediately after data is written. In the timed update mode, LDAC<0..1> follow the UPDATE signal for primary analog output or the UPDATE2 signal for secondary analog output. In the immediate update mode, LDAC<0..1> are inverted versions of the DAC write signals TMRDACWR and CPUDACWR.

3.4.3 Data Interfaces

The DAQ-STC supports several methods for transferring analog output data from computer memory to the DACs. In CPU-driven analog output, the CPU writes the output data directly to the DACs. In DAQ-STC-driven analog output, however, CPU writes are usually too inefficient to achieve high data throughput. For this reason, the DAQ-STC supports three other modes for transferring data to the DACs. In the FIFO data interface mode, output data is buffered locally in the data FIFO. When the data FIFO empties, it can be filled using DMA or interrupts, or through the FIFO retransmit, in local buffer mode. In the serial link data interface mode, the output data comes through a serial link from another board. In the unbuffered data interface mode, the output data is written directly to the DACs using DMA. This section discusses the three methods for transferring data to the DACs.

3.4.3.1 FIFO Data Interface

In the FIFO data interface mode, the analog output data is buffered locally in the data FIFO. The data FIFO reports its status to the DAQ-STC through the inputs AOFFF, AOFHF, and AOFEF, which are the data FIFO full, half-full, and empty flags, respectively. The DAQ-STC uses the FIFO status to generate a DMA request or FIFO interrupt notifying the system that the FIFO requires data. The DMA request appears on the output signal AOFREQ, and the FIFO interrupt appears on one of the interrupt lines IRQ_OUT<0..7>. The DAQ-STC generates the DMA request or FIFO interrupt on one of four different FIFO flag conditions, including assert on FIFO empty, assert on FIFO less than half-full, assert on FIFO not full, and assert on FIFO less than half-full and deassert on FIFO full.

If the data FIFO empties while a data sequence is being written to the DACs, the TMRDACWR pulses pause until the data FIFO has an opportunity to refill. Figure 3-5 shows an example of the FIFO data interface mode using AOFREQ asserting on FIFO empty. The UPDATE signal causes the TMRDACWR signal to begin writing the next output data values. After TMRDACWR writes data to three channels, the data FIFO empties, causing AOFEF and AOFREQ to assert. AOFREQ instructs the DMA controller to refill the data FIFO. When the FIFO refills, AOFEF deasserts, allowing the remaining three channels to be written.

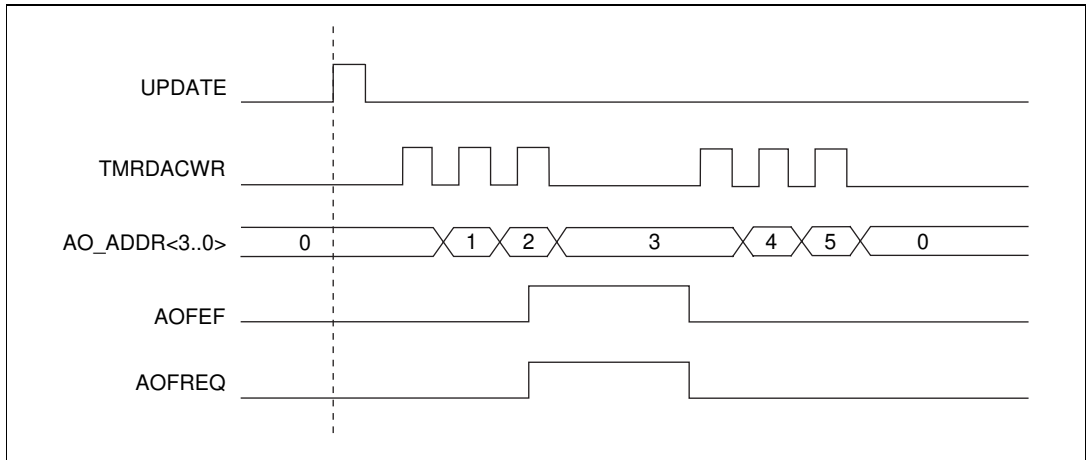

Figure 3-5. FIFO Data Interface

The DAQ-STC also supports a local buffer mode for analog output, which reduces analog output bus usage to zero. In local buffer mode, the desired waveform is written into the data FIFO, and the FIFO contents are repeated a number of times. The AOFEF signal notifies the DAQ-STC that the data FIFO is empty, and the AOFFRT signal instructs the data FIFO to retransmit its data. When the FIFO becomes empty, the DAQ-STC asserts the AOFFRT signal which sets the FIFO read pointer back to the first location of the FIFO. The waveform can then be output again.

Figure 3-6 shows an example of the local buffer mode with two iterations of a single buffer. The buffer contains three data points, so assume that the CPU writes three data values into the data FIFO. The TMRDACWR signal transfers data from the data FIFO to the DACs. After three data points are transferred, the AOFEF asserts, causing the AOFFRT signal to pulse. This refills the FIFO with the same three data points for the next iteration of the buffer. In Figure 3-6, the UC_TC (UC counter TC) signal pulses at the end of each buffer. The relationship between the UPDATE pulses and the UC counter is discussed in section [3.4.5, Buffer Timing and Control for Primary Analog Output](#).

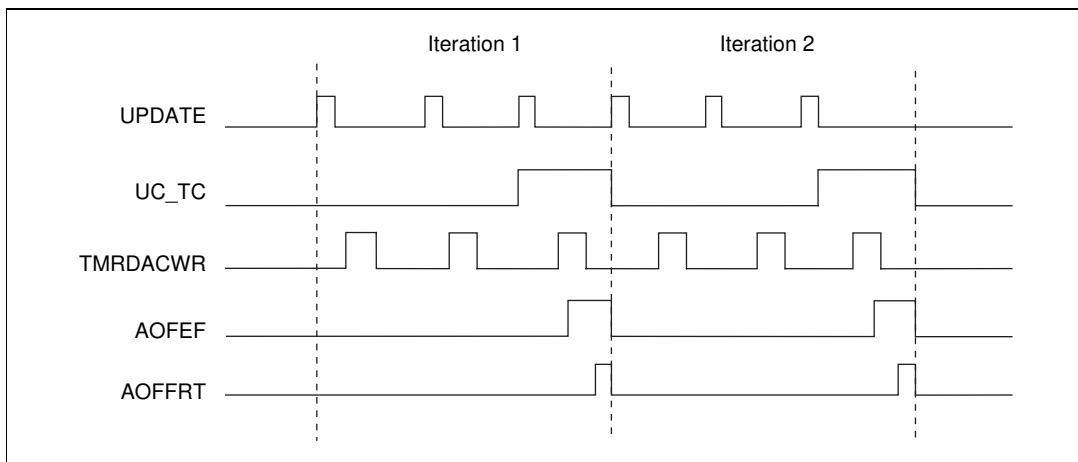

Figure 3-6. Local Buffer Mode

3.4.3.2 Serial Link Data Interface

In the serial link data interface mode, the DACs receive analog output data through a serial data link (or some other interface) instead of through the analog output data FIFO. In this mode, the AOFEF signal is controlled by the data link. When AOFEF is active, the TMRDACREQ signal asserts in place of the write signal TMRDACWR, indicating that data is required for a DAC write operation. The assertion of TMRDACREQ initiates a transfer across the data link. Once the transfer completes, the AOFEF signal is released, allowing the DAC write to complete.

Figure 3-7 shows an example waveform from a serial link data interface. AOFEF is initially held active. After the UPDATE pulse, TMRDACREQ is asserted where the TMRDACWR pulse should be, causing the serial data link to transmit data. Once the serial link data transfer completes, AOFEF is released, allowing the write to occur.

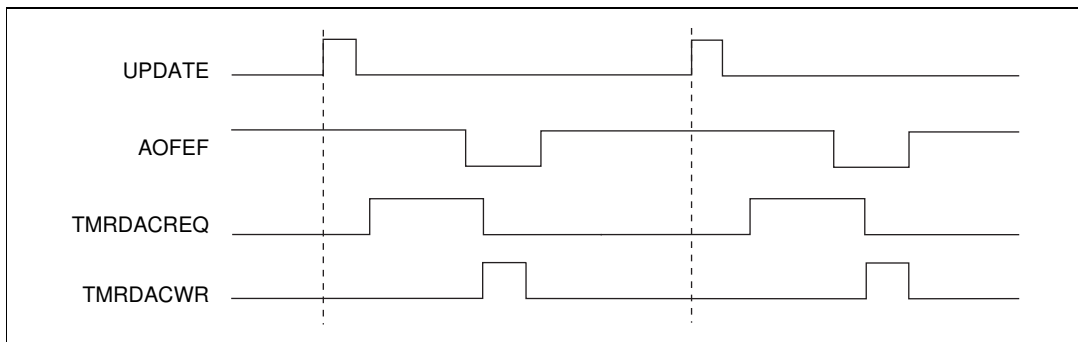

Figure 3-7. Serial Link Data Interface

3.4.3.3 Unbuffered Data Interface

In the unbuffered data interface mode, the DMA controller writes data directly to the DACs. This mode is primarily used in low cost data acquisition boards that do not have a data FIFO. The UPDATE signal performs the updating of the DACs as before. The TMRDACWR signal becomes the DMA request, indicating that new data is needed for the analog output. The AOFEF input becomes the DMA acknowledge, indicating that the DMA data is ready for the write. The CPUDACWR signal pulses each time AOFEF asserts to write the DMA data to the DACs. The TMRDACWR signal remains asserted until the completion of the last CPUDACWR. Figure 3-8 shows an example of the unbuffered data interface mode where the DAQ-STC writes output data to the first three DACs.

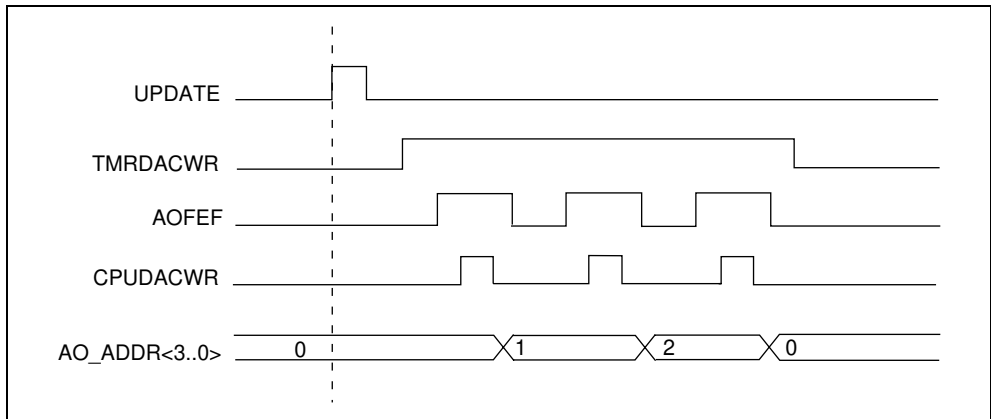

Figure 3-8. Unbuffered Data Interface

3.4.4 Update Timing for Primary Group Analog Output

In DAQ-STC-driven analog output, the UPDATE signal allows DACs for multiple channels to be updated simultaneously. As discussed in section 3.3, *Simplified Model*, of this chapter, the UPDATE signal can be generated internally or externally. This section discusses the internal and external UPDATE sources and the timing parameters associated with each source.

3.4.4.1 Internal UPDATE

In the internal UPDATE mode, UPDATE pulses are generated by UI_TC (UI counter TC). The START1 trigger causes the UI counter to begin counting. The UI counter has dual-load registers, which allow for two timing parameters at the UPDATE timing level. The first parameter (A) gives the delay from START1 to the first UPDATE. The second parameter (B) gives the delay between UPDATE pulses. Figure 3-9 shows a sequence of UPDATE pulses and indicates the timing parameters that are available.

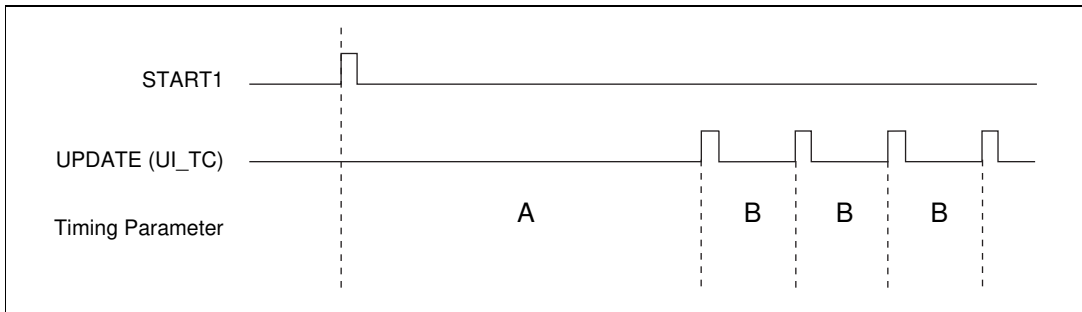

Figure 3-9. Internal UPDATE Timing

3.4.4.2 External UPDATE

In the external UPDATE mode, externally generated UPDATE pulses enter the DAQ-STC through one of the PFI<0..9> or RTSI_TRIGGER<0..6> inputs or general-purpose counter 1. Alternately, the UPDATE may come from general-purpose counter 1. Only one timing parameter is available in this model—the delay between UPDATE pulses. This delay is determined by the period of the external UPDATE signal. The delay from START1 to the first UPDATE depends upon the relationship between the START1 trigger and the external UPDATE, and can vary. Figure 3-10 shows a sequence of externally timed UPDATE pulses and indicates the delay from START1 to the first UPDATE.

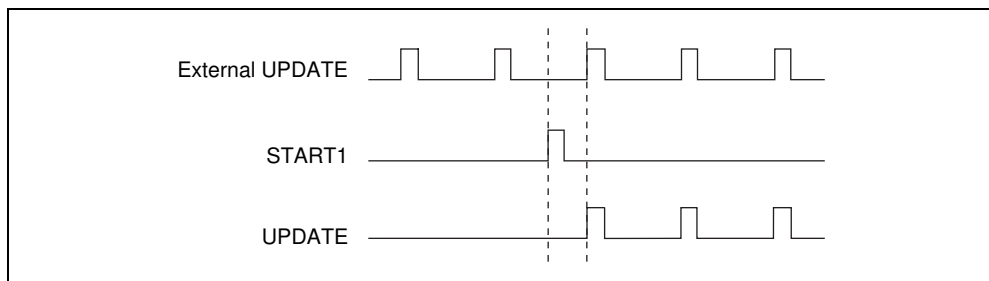

Figure 3-10. External UPDATE Timing

3.4.5 Buffer Timing and Control for Primary Analog Output

Sequences of UPDATE pulses are organized into buffers. A buffer consists of a fixed number of data points that are output at a constant rate. The DAQ-STC can easily provide timing for multiple iterations of a single buffer (MISB). When a sequence of buffers is output consecutively, a waveform is generated. A waveform may consist of one MISB or it may consist of multiple MISBs. The DAQ-STC provides direct hardware support for the output of a single MISB, output of one MISB followed immediately by a second MISB, and output of two MISBs which alternate. The DAQ-STC can generate even more complex waveforms

using software interrupts. This section discusses the buffer timing modes available with the DAQ-STC.

3.4.5.1 Single-Buffer Mode

In the single-buffer mode, the DAQ-STC provides UPDATE timing for one MISB. Software programs the UC counter with the number of points in the buffer and programs the BC counter with the number of buffer repetitions. The START1 trigger initiates the analog output. Single-buffer mode analog output can be retriggeable or nonretriggeable. In the retriggeable single-buffer mode, additional START1 pulses will initiate additional analog output operations. In the nonretriggeable single-buffer mode, only one analog output operation is allowed and the final UPDATE pulse in the MISB is masked. Therefore, you need to add an extra UPDATE pulse to the first buffer in the nonretriggeable single-buffer mode.

Figure 3-11 shows an example of the nonretriggeable single-buffer mode. The buffer contains five data points, so the UC counter is programmed to count six UPDATE pulses in the following buffers. The buffer is repeated twice, so the BC counter is programmed to count two UC_TC pulses. The BC_TC (BC counter TC) signal causes the MISB to terminate and masks the final UPDATE pulse.

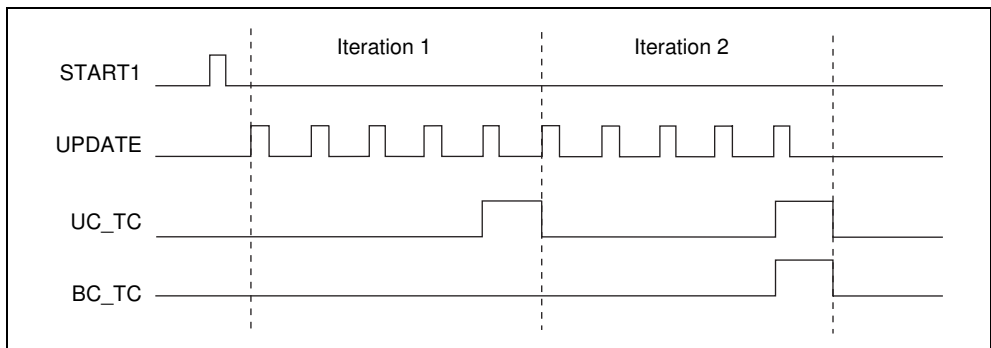

Figure 3-11. Single-Buffer Mode

3.4.5.2 Continuous Mode

In the single-buffer mode, the BC counter indicates when an MISB should terminate. In the continuous mode, however, the MISB does not terminate at a predetermined time. Instead, the MISB continues until the hardware receives an End_On_UC_TC command, an End_On_BC_TC command, or an AO_Reset. The End_On_UC_TC command causes the MISB to terminate at the next UC_TC, corresponding to the end of the current buffer. The End_On_BC_TC command causes the MISB to terminate at the next BC_TC. The AO_Reset causes the MISB to terminate immediately.

In the continuous mode, the DAQ-STC provides UPDATE timing for more than one MISB. Since each counter has two load registers, the two-MISB case can be handled directly in hardware. For more than two MISBs, software intervention is required to load the parameters for each MISB during the output of the previous MISB. For example, in the three-MISB case software must load the parameters for MISB three during MISB two. This software intervention is called waveform staging. Refer to section 3.4.5.3, *Waveform Staging*, for more information. The START1 trigger initiates the analog output.

Figure 3-12 shows an example of two MISBs in continuous mode. The first MISB contains two iterations of a two-point buffer. The second MISB contains one iteration of a four-point buffer. Note that the UPDATE pulses for the second MISB occur at a lower rate than the UPDATE pulses for the first MISB. This type of waveform is possible in the internal UPDATE mode because the UI counter can be programmed with a new value for each MISB. Also note that the DAQ-STC defines the UPDATE interval to last from the beginning of the current UPDATE to the beginning of the next UPDATE. Thus, the interval between the fourth UPDATE and the fifth UPDATE corresponds to the UPDATE interval for MISB 1 rather than the UPDATE interval for MISB 2.

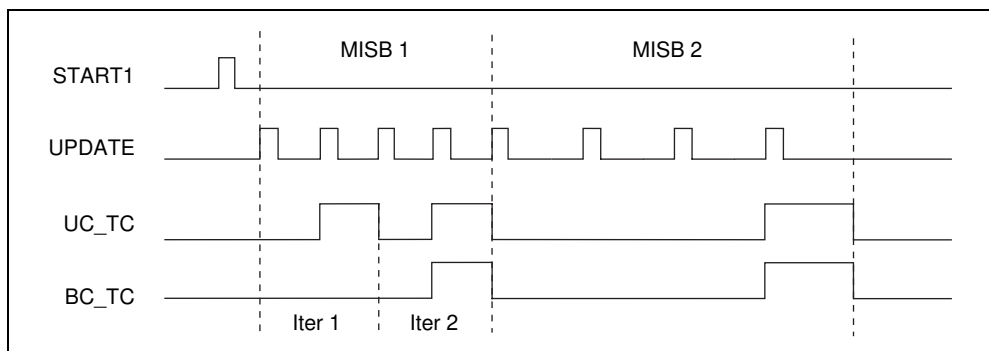

Figure 3-12. Continuous Mode

3.4.5.3 Waveform Staging

Waveform staging refers to the software action required to implement a sequence of more than two MISBs. In a programming sequence that occurs prior to the START1 trigger, software loads the parameters for the first two MISBs. Software also configures the counters to switch load registers after each MISB has completed, providing for the switch from one MISB to the next. While the second MISB is in progress, software loads the parameters for the third MISB into the unused load registers. Switching between load registers occurs at the end of each MISB, that is, at BC_TC. This arrangement allows the software a maximum latency of up to the duration of the MISB in progress to finish loading the parameters for the next MISB into the alternate load register set.

The DAQ-STC provides error detection for the case in which the next parameters are not written in the allotted time. The error-detection circuit is armed on each BC_TC. If a software clear does not occur before the next BC_TC, the error-detection circuit latches an error condition.

3.4.5.4 Mute Buffers

In some cases it is necessary to provide a programmable delay between MISB outputs. The mute buffer provides a way to accomplish this. The delay is implemented as an MISB section where all of the internal counters operate but the output signals are shut off. A single control bit (AO_Mute) determines whether an MISB section is muted. For the case in which a single MISB is repeatedly output with a mute MISB serving as a delay, software is required only to shut off the waveform generation at an appropriate time.

Figure 3-13 shows an example of how mute buffers can be used to introduce pauses in the analog output timing. In the example, a single buffer containing two points is repeated twice, generating four update pulses. A mute buffer is then inserted to give the desired delay. This process can be repeated as many times as required.

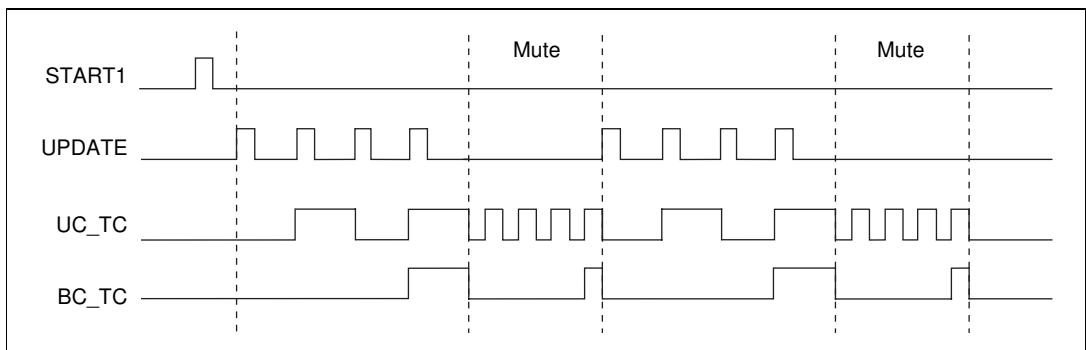

Figure 3-13. Mute Buffers

3.4.5.5 Master/Slave Trigger

Master/slave triggers should be used whenever it is required for multiple DAQ-STC ASICs to output data in a synchronized manner, that is, when multiple ASICs share the same START1 trigger. In master/slave triggering, one DAQ-STC is designated to be the master trigger ASIC, sourcing the START1 trigger to the other ASICs through the PFI<0..9> or RTSI_TRIGGER<0..6> interface. This provides better synchronization performance than if all DAQ-STC ASICs received the same START1 trigger independently, because different ASICs may synchronize differently. In master/slave triggering, all DAQ-STC AOTM modules are timed from a common source. The master ASIC delays recognition of the START1 trigger by one source period to allow the slave ASICs adequate time to receive the trigger. On the

following source edge, all of the ASICs simultaneously begin the programmed waveform generation. Master/slave triggering can be used with any of the buffer timing modes previously discussed.

3.4.6 Secondary Analog Output

A secondary independent update interval output is controlled by a 16-bit binary down counter (UI2) with dual-load registers. The analog output group served by UI2 is an interrupt-driven group. All the parameters, except gating, for the second independent update output—trigger, update count, buffer count, and addressing—are handled in software.

3.5 Pin Interface

The I/O signals relevant to the analog output are listed in Table 3-1. An asterisk following a pin name indicates that the default polarity for that pin is active low.

Pin Type Notation:

IU	Input, pull up (50 k Ω)
O4TU	Output, 4 mA sink, 2.5 mA source tri-state, pull up (50 k Ω)
O9TU	Output, 9 mA sink, 5 mA source tri-state, pull up (50 k Ω)

Table 3-1. Pin Interface

Pin Name	Type	Description
AO_ADDR<0..3>	O4TU	AO Address Outputs—These active high outputs indicate which DAC channel is being accessed. In multiple-channel analog output mode, the AO_ADDR lines increment starting from 0 on each TMRDACWR trailing edge. During a CPU DAC write, the AO_ADDR lines take on the value present on the inputs A<0..3>. Destination: DAC address selector. Related bitfields: AO_Multiple_Channels, AO_Number_Of_Channels.
AOFEF*	IU	Data FIFO Empty Flag—This input is used to generate the FIFO interrupt and the FIFO request signal (AOFREQ) based on the status of the FIFO, and to delay the TMRDACWR pulses when the AO data FIFO is empty. The input polarity is selectable, and the input state can be directly observed in one of the status registers. Source: AO data FIFO. Related bitfields: AO_FIFO_Flags_Polarity, AO_FIFO_Empty_St.

Table 3-1. Pin Interface (Continued)

Pin Name	Type	Description
AOFFF*	IU	Data FIFO Full Flag—This input is used to generate the FIFO interrupt and the FIFO request signal (AOFREQ) based on the status of the FIFO. The input polarity is selectable, and the input state can be directly observed in one of the status registers. Source: AO data FIFO. Related bitfields: AO_FIFO_Flags_Polarity, AO_FIFO_Full_St.
AOFHF*	IU	Data FIFO Half-full Flag—This input is used to generate the FIFO interrupt and the FIFO request signal (AOFREQ) based on the status of the FIFO. The input polarity is selectable, and the input state can be directly observed in one of the status registers. Source: AO data FIFO. Related bitfields: AO_FIFO_Flags_Polarity, AO_FIFO_Half_Full_St.
AOFFRT*	O4TU	Data FIFO Retransmit—This active low output instructs the data FIFO to retransmit its contents. It is used primarily in the local buffer mode. When enabled, AOFFRT pulses each time AOFEF indicates a FIFO empty condition. Destination: AO data FIFO. Related bitfields: AO_FIFO_Retransmit_Enable.
AOFREQ	O9TU	Data FIFO Request—This output is a FIFO request signal that indicates that the data FIFO needs to be loaded with output data. The AOFREQ signal is generated directly from the data FIFO status flags—AOFEF, AOFHF, and AOFFF. The AOFREQ generation conditions are: assert on empty FIFO; assert on half-full or less FIFO; assert on less than full FIFO; assert on half-full or less FIFO, deassert on full FIFO. Output polarity is selectable. Destination: DMA Controller or CPU. Related bitfields: AO_AOFREQ_Polarity, AO_AOFREQ_Enable, AO_FIFO_Mode.
BC_TC	O4TU	The BC Counter Terminal Count Signal—Output polarity is active high. Related bitfields: Misc_Counter_TCs_Output_Enable.

Table 3-1. Pin Interface (Continued)

Pin Name	Type	Description
CPUDACREQ*	IU	CPU Request for Access to the DAC—This active low input indicates that the CPU is attempting a write cycle to the DAC. The assertion of CPUDACREQ causes CHRDY_OUT to be deasserted immediately. When the DAC becomes available, the DAC-STC fulfills the CPU request by passing the lowest four bits of the address lines A<0..3> onto the DAC address lines AO-ADDR<0..3> and pulsing the CPUDACWR signal. CHRDY_OUT is released when the write completes. Source: CPU bus interface.
CPUDACWR*	O4TU	CPU Write to the DAC—This active low output serves as the DAC write signal generated by the CPU. The CPUDACWR signal pulses once following the assertion of CPUDACREQ. Timing for CPUDACWR is based on AO_OUT_TIMEBASE, and the pulsewidth is selectable. Destination: DACs. Related Bitfields: AO_TMRDACWR_Pulse_Width.
DACWR*<0..1>	O4TU	DAC Write Strokes—These pins serve as write strobes for DACs, combining the TMRDACWR and CPUDACWR signals. In the single-DAC mode, DACWR0 pulses on every write to an even channel and DACWR1 pulses on every write to an odd channel. In the dual DAC mode, DACWR0 pulses on every write and DACWR1 is not used. Output polarity is active low. Destination: DACs. Related bitfields: AO_Number_Of_DAC_Packages, AO_TMRDACWR_Pulse_Width.
LDAC*<0..1>	O4TU	DAC Load—These pins serve as DAC updates in the double-buffered DAC case. Two update modes are supported, timed update and immediate update. In the timed update mode, LDAC<0..1> are programmed to output either UPDATE or UPDATE2. In the immediate update mode, LDAC<0..1> are inverted versions of the DAC write signals TMRDACWR and CPUDACWR. Output polarity is active low. Destination: DACs. Related bitfields: AO_LDACi_Source_Select, AO_DACi_Update_Mode.

Table 3-1. Pin Interface (Continued)

Pin Name	Type	Description
TMRDACREQ	O9TU	DAQ-STC Data Request—This output indicates that there is no data available for the timer initiated write to the DAC. The signal is used by the serial link data interface to the DAC. When AOFEF is active, TMRDACREQ is asserted at the same time that the TMRDACWR would have been asserted had data been available. TMRDACREQ is released on the AO_OUT_TIMEBASE edge following AOFEF going inactive. Output polarity is active high. Destination: Serial data interface.
TMRDACWR*	O4TU	DAQ-STC Write to the DAC—This output serves as the DAC write signal generated by the DAQ-STC whenever data from the data FIFO needs to be written to the DACs. Following each UPDATE, the TMRDACWR signal pulses a number of times to load data into the DACs, according to the number of output channels. When AOFEF is asserted, the TMRDACWR pulses pause until the AO data FIFO can be refilled. Timing for TMRDACWR is based on AO_OUT_TIMEBASE. The signal can also be used as a DMA request on a board without an data FIFO in the unbuffered data interface mode. The output polarity is active low, and the pulsewidth is selectable. Destination: DACs. Related bitfields: AO_DMA_PIO_Control, AO_FIFO_Enable, AO_Not_An_UPDATE, AO_TMRDACWR_Pulse_Width, AO_TMRDACWRs_In_Progress_St.
UC_TC	P4TU	The UC Counter Terminal Count Signal—Output polarity is active high. Related bitfields: Misc_Counter_TCs_Output_Enable.

Table 3-1. Pin Interface (Continued)

Pin Name	Type	Description
UPDATE*	O9TU	Primary Update—This output is used to update the DACs. The hardware generates UPDATE by passing the output of the UPDATE selector (SCLK) through pulsewidth and polarity selection circuitry. Output polarity is selectable. Destination: DACs. Options: Active Low, Active High, Ground, High Z. Related bitfields: AO_UPDATE_Output_Select, AO_UPDATE_Pulse, AO_UPDATE_Original_Pulse, AO_UPDATE_Pulse_Timebase, AO_UPDATE_Pulse_Width.
UPDATE2*	O9TU	Secondary Update—This output is the secondary update signal to the DACs. The hardware generates UPDATE2 by passing the internal UI2_TC (UI2 counter TC) signal through pulsewidth and polarity selection circuitry. Output polarity is selectable. Destination: DACs. Options: Active Low, Active High, Ground, High Z. Related bitfields: AO_UPDATE2_Output_Select, AO_UPDATE2_Output_Toggle, AO_UPDATE2_Pulse, AO_UPDATE2_Original_Pulse, AO_UPDATE2_Pulse_Timebase, AO_UPDATE2_Pulse_Width.

3.6 Programming Information

This section presents programming information that is specific to the AOTM. For general information about programming the DAQ-STC, see section 2.6, *Programming Information*.

3.6.1 Programming for a Primary Analog Output Operation

This section contains detailed programming information for bit-level programming of the primary AOTM for specialized applications. The programs are presented in a bottom-up fashion. This section lists functions that can be used to configure the primary AOTM for various operations. The functions are then assembled into a complete program in section 3.6.1.14, *Primary Analog Output Program*.

Most of the programming sequences presented here must be executed exactly as shown. Bitfield assignment is a pseudocode instruction of the form <bitfield name> = <value>. Pseudocode sequences enclosed in braces that contain only bitfield assignments can normally be executed in any order, or simultaneously, if possible. If the sequence must be executed in exact order, the character Σ marks the boundary between two groups of assignments that have to be executed sequentially. For example, in the following pseudocode, the first bitfield assignment must be performed first; the second and third assignments may then be executed in any order; but the fourth bitfield assignment must be executed after the second and third

bitfield assignments. Other programming constructs, such as if-then, should be executed in the order shown.

```

{
    FOUT_Enable = 0;
    Σ
    FOUT_Timebase_Select = 0 (FOUT_IN_TIMEBASE1) or 1 (IN_TIMEBASE2);
    FOUT_Divider = 0 (for division factor 16) or 1-15 (for division factor 1-15);
    Σ
    FOUT_Enable = 1;
}

```

The directives `Begin critical section` and `End critical section` mark the beginning and end of critical sections in the ensuing pseudocode. All statements under these directives must be synchronized with the interrupt service routines; in other words, while the code fragment under these directives is executing in the foreground, all interrupt-time-specific code must be prevented from executing in the background.

Under some single-tasking operating systems, such as DOS, the directives `Begin critical section` and `End critical section` directly map to `CLI` and `STI` instructions, respectively. However, other operating systems may require specific primitives to achieve this functionality.

3.6.1.1 Overview

The DAQ-STC has two groups of counters dedicated to analog output timing and control. The primary group contains three counters and the secondary group contains one counter. Counters in the first group are UI, UC, and BC. The second group consists of the UI2 counter. Since the two groups are almost independent, the programming examples are separate. This section discusses programming for the primary group. Refer to section 3.6.6, [Programming for a Secondary Analog Output Group Operation](#), for a discussion of the secondary group.

3.6.1.2 Resetting

Assume the primary analog output section of the DAQ-STC was set up to perform an unknown operation. The object is to stop any activities in progress.

```

Function AO_Reset_All
{
    Begin critical section;
    AO_Configuration_Start = 1;
    Σ
    AO_Disarm = 1;
    Σ
    AO_Personal_Register = 0;
    AO_Command_1_Register = 0;
}

```



```

AO_Command_2_Register = 0;
AO_Mode_1_Register = 0;
AO_Mode_2_Register = 0;
AO_Output_Control_Register = 0;
AO_Mode_3_Register = 0;
AO_START_Select_Register = 0;
AO_Trigger_Select_Register = 0;
Σ
AO_BC_TC_Interrupt_Enable = 0;
AO_START1_Interrupt_Enable = 0;
AO_UPDATE_Interrupt_Enable = 0;
AO_START_Interrupt_Enable = 0;
AO_STOP_Interrupt_Enable = 0;
AO_Error_Interrupt_Enable = 0;
AO_UC_TC_Interrupt_Enable = 0;
AO_FIFO_Interrupt_Enable = 0;
Σ
AO_BC_Source_Select = 1;
AO_BC_TC_Trigger_Error_Confirm = 1;
AO_BC_TC_Error_Confirm = 1;
AO_UC_TC_Interrupt_Ack = 1;
AO_BC_TC_Interrupt_Ack = 1;
AO_START1_Interrupt_Ack = 1;
AO_UPDATE_Interrupt_Ack = 1;
AO_START_Interrupt_Ack = 1;
AO_STOP_Interrupt_Ack = 1;
AO_Error_Interrupt_Ack = 1;
AO_Configuration_End = 1;
End critical section;
}

```

Perform the `AO_Board_Personalize` programming function in order to bring the primary AO module of DAQ-STC into a known state. You can then program the primary AO module for any desired operation.

3.6.1.3 Board Power-up Initialization

Use this function to program software-selectable options in the primary analog output module of the DAQ-STC that depend on the properties of the board or device the DAQ-STC is on. The options include polarity and pulsewidth of commonly used signals. You need to execute this function every time after you invoke the `AO_Reset_All` function and before you perform any analog output operation using the DAQ-STC. If you are programming a DAQ-STC that is a part of a data acquisition system, the document describing the register-level programming for that system should contain information about the proper selections to make in this function.

Function AO_Board_Personalize

```

{
    Begin critical section;
    AO_Configuration_Start = 1;
    AO_Fast_CPU = 0 (slow CPU interface) or 1 (fast CPU interface);
    AO_Source_Divide_By_2 = 0 (AO_IN_TIMEBASE1 equals IN_TIMEBASE) or
        1 (AO_IN_TIMEBASE1 is IN_TIMEBASE divided by two);
    AO_Output_Divide_By_2 = 0 (AO_OUT_TIMEBASE is the same as IN_TIMEBASE)
        or 1 (AO_OUT_TIMEBASE is IN_TIMEBASE divided by two);
    AO_UPDATE_Pulse_Timebase = 0 (selected by AO_UPDATE_Pulse_Width) or
        1 (selected by AO_UPDATE_Original_Pulse);
    AO_UPDATE_Pulse_Width = 0 (3–3.5 AO_OUT_TIMEBASE periods) or
        1 (1–1.5 AO_OUT_TIMEBASE periods);
    AO_UPDATE_Output_Select = 0 (high Z) or 1 (ground) or 2 (enable, active low) or
        3 (enable, active high);
    AO_DMA_PIO_Control = 0 (FIFO data interface mode) or
        1 (unbuffered data interface mode);
    AO_AOFREQ_Enable = 0 (disabled) or 1 (enabled);
    AO_AOFREQ_Polarity = 0 (active high) or 1 (active low);
    AO_TMRDACWR_Pulse_Width = 0 (3 AO_OUT_TIMEBASE periods) or
        1 (2 AO_OUT_TIMEBASE periods);
    AO_FIFO_Enable = 0 (TMRDACWR signal is disabled) or
        1 (TMRDACWR signal is enabled);
    AO_FIFO_Flags_Polarity = 0 (active low) or 1 (active high);
    AO_Number_Of_DAC_Packages = 0 (dual-DAC mode) or 1 (single-DAC mode);
    AO_Configuration_End = 1;
    End critical section;
}

```

3.6.1.4 Trigger Signals

Use this function to select the signal that will trigger the analog output operation and to program the DAQ-STC AOTM to recognize single or multiple trigger signals.

Function AO_Triggering

```

{
    Begin critical section;
    AO_Configuration_Start = 1;
    If (local buffer mode with pauses) OR (continuous mode) OR (waveform staging) then
        AO_Trigger_Once = 0;

    Else
        AO_Trigger_Once = 1;
    If (software triggered) then
    {
        AO_START1_Select = 0;
        AO_START1_Polarity = 0;
    }
}

```

```

        AO_START1_Edge = 1;
        AO_START1_Sync = 1;
    }
    Else
    {
        AO_START1_Select = 1 through 10 (PFI<0..9>) or 11 through 17
        (RTSI_TRIGGER<0..6>);
        AO_START1_Polarity = 0 (active high) or 1 (active low);
        AO_START1_Edge = 0 (edge detection disabled) or 1 (edge detection enabled);
        AO_START1_Sync = 0 (synchronization disabled) or 1 (synchronization enabled);
    }
    AO_Delayed_START1 = 0 (use the START1 trigger immediately) or 1 (delay the
    START1 trigger by synchronizing it to the BC source);
    Σ
    AO_Trigger_Length = 0 (PFI6/AO_START1 will output DA_START1) or
    1 (PFI6/AO_START1 will output a pulse stretched version of DA_ST1ED);
    AO_Configuration_End = 1;
    End critical section;
}

```

3.6.1.5 Number of Buffers

Use this function to select the number of updates to be performed (corresponding to the number of points in the buffer) and the number of buffer iterations. If you are using the local buffer mode with mute buffers, this function will set the part of the delay parameters that correspond to the number of points in the mute buffer and the number of iterations of that buffer. If you are using waveform staging, this function enables and disables muting for the first two buffers.

The variables `ao_last_load_register` and `ao_tick_count_to_use` introduced in this function will be used later in the functions for waveform staging (`AO_Staged_ISR`) and changing the update rate during an output operation (`AO_Rate_Change`).

For waveform staging operation, we assume that the parameters for each stage are stored in an array, defined as follows:

```

bc_new_ticks           /*contains the number buffer iterations in each MISB*/
uc_new_ticks           /*contains the number of updates in each buffer of the MISB*/
new_mute_flag          /*indicates whether the MISB will be muted (1 indicates muting)*/

```

```

Function AO_Counting
{
    Begin critical section;
    AO_Configuration_Start = 1;
    Declare variables

```

```

    ao_last_load_register,    /*indicates which load register was used
                             previously*/
    ao_tick_count_to_use;    /*indicates which parameter in the array should
                             be used*/
If (waveform staging) then
{
    AO_Continuous = 1;
    AO_Mute_A = new_mute_flag[0];
    AO_BC_Initial_Load_Source = 0;
    AO_BC_Load_A = bc_new_ticks[0] - 1;
    Σ
    AO_BC_Load = 1;
    Σ
    AO_UC_Initial_Load_Source = 0;
    AO_UC_Load_A = uc_new_ticks[0];
    Σ
    AO_UC_Load = 1;
    Σ
    AO_UC_Load_A = uc_new_ticks[0] - 1;
    AO_Mute_B = new_mute_flag[1];
    AO_BC_Load_B = bc_new_ticks[1] - 1;
    AO_UC_Load_B = uc_new_ticks[1] - 1;
    AO_BC_Reload_Mode = 1;
    AO_UC_Switch_Load_Every_BC_TC = 1;
    ao_tick_count_to_use = 2;
    ao_last_load_register = B;
}
Else if (local buffer mode with pauses) then
{
    AO_Continuous = 1;
    AO_Mute_A = 0;
    AO_Mute_B = 1;
    AO_BC_Initial_Load_Source = 0;
    AO_BC_Load_A = number of buffer iterations - 1;
    Σ
    AO_BC_Load = 1;
    Σ
    AO_UC_Initial_Load_Source = 0;
    AO_UC_Load_A = number of updates in each buffer;
    Σ
    AO_UC_Load = 1;
    Σ
    AO_UC_Load_A = number of updates in each buffer - 1;
    AO_BC_Load_B = number of buffer repetitions in pause MISB - 1;
    AO_UC_Load_B = number of updates in each buffer of pause MISB - 1;
    AO_BC_Reload_Mode = 1;
    AO_UC_Switch_Load_Every_BC_TC = 1;
}

```

```

Else
{
    AO_Continuous = 0 (AO will stop on BC_TC) or 1 (AO will continue until END
command);
    AO_BC_Initial_Load_Source = 0;
    AO_BC_Load_A = number of buffer iterations - 1;
     $\Sigma$ 
    AO_BC_Load = 1;
     $\Sigma$ 
    AO_UC_Initial_Load_Source = 0;
    AO_UC_Load_A = number of updates in each buffer;
     $\Sigma$ 
    AO_UC_Load = 1;
     $\Sigma$ 
    AO_UC_Load_A = number of updates in each buffer - 1;
    ao_last_load_register = A;
}
AO_Configuration_End = 1;
End critical section;
}

```

3.6.1.6 Update Selection

Use this function to select the update event. You can specify an update rate by choosing an internally generated periodic event.

For waveform staging operation in the internal update mode, we assume that the parameters for each stage are stored in an array, defined as follows:

```
ui_new_ticks          /*contains the number of clocks between updates in each MISB*/
```

```
Function AO_Updating
```

```

{
    Begin critical section;
    AO_Configuration_Start = 1;
    If (internal UPDATE mode) then
    {
        AO_BC_Gate_Enable = 0;
        AO_UPDATE_Source_Select = 0;
        AO_UPDATE_Source_Polarity = 0;
        If (UI source is AO_IN_TIMEBASE1) then
        {
            AO_UI_Source_Select = 0;
            AO_UI_Source_Polarity = 0;
        }
        Else if (UI source is IN_TIMEBASE2) then
        {

```

```

    AO_UI_Source_Select = 20;
    AO_UI_Source_Polarity = 0;
}

Else
{
    AO_UI_Source_Select = 1 through 10 (PFI<0..9>) or 11 through 17
    (RTSI_TRIGGER<0..6>);
    AO_UI_Source_Polarity = 0 (rising edge) or 1 (falling edge);
}
If (waveform staging) then
{
    AO_UI_Initial_Load_Source = 0;
    AO_UI_Load_A = ui_new_ticks[0] - 1;
     $\Sigma$ 
    AO_UI_Load = 1;
     $\Sigma$ 
    AO_UI_Load_B = ui_new_ticks[1] - 1;
    AO_UI_Relaod_Mode = 7;
}
Else
{
    AO_UI_Initial_Load_Source = 0;
    AO_UI_Reload_Mode = 0;
    If (there is no special delay from START1 to first update) then
    {
        AO_UI_Load_A = number of clocks between each update - 1;
         $\Sigma$ 
        AO_UI_Load = 1;
    }
    Else
    {
        AO_UI_Load_A = number of clocks between START1 and first update - 1;
         $\Sigma$ 
        AO_UI_Load = 1;
         $\Sigma$ 
        AO_UI_Load_A = number of clocks between each update - 1;
    }
    If (local buffer mode with pauses) then
    {
        AO_UI_Load_B = number of clocks between each update in the mute
        MISB - 1;
        AO_UI_Reload_Mode = 7;
    }
}
}
Else if (UPDATE source is the GOUT1 signal from general-purpose counter 1) then
{

```

```

    AO_BC_Gate_Enable = 1;
    AO_UPDATE_Source_Select = 20;
    AO_UPDATE_Source_Polarity = 0;
}
Else /*external UPDATE mode*/
{
    AO_BC_Gate_Enable = 1;
    AO_UPDATE_Source_Select = 1 through 10 (PFI<0..9>) or
                            11 through 17 (RTSI_TRIGGER<0..6>);
    AO_UPDATE_Source_Polarity = 0 (rising edge) or 1 (falling edge);
}
AO_Configuration_End = 1;
End critical section;
}

```

Another feature provided by the DAQ-STC in the external UPDATE mode is the BC_GATE (BC Counter Gate). The BC_GATE provides a mechanism for blocking the external UPDATE pulses. If AO_BC_Gate_Enable is set to 1, the BC_GATE enables the external UPDATE pulses whenever the BC counter is enabled to count, and blocks the external UPDATE pulses whenever the BC counter is not enabled to count. The BC_GATE must be disabled when internally generated UPDATE pulses are used.

3.6.1.7 Channel Select

This function lets you update one or more analog output channels. If you choose single-channel analog output, select the channel number. If you choose multiple-channel analog output, you may select how many, but channel numbers must be ascending continuously from 0.

Function AO_Channels

```

{
    Begin critical section;
    AO_Configuration_Start = 1;
    If (single channel) then
    {
        AO_Multiple_Channels = 0;
        AO_Number_Of_Channels = output channel number;
    }
    Else
    {
        AO_Multiple_Channels = 1;
        AO_Number_Of_Channels = number of output channels - 1;
    }
    AO_Configuration_End = 1;
    End critical section;
}

```

3.6.1.8 LDAC Source and UPDATE Mode

Use this function to set the source and update mode for the LDAC<0..1> signals.

```
Function AO_LDAC_Source_And_Update_Mode
{
    Begin critical section;
    AO_Configuration_Start = 1;
    AO_LDAC0_Source_Select = 0 (LDAC0 will output UPDATE) or
                            1 (LDAC0 will output UPDATE2);

    AO_DAC0_Update_Mode = 0 (immediate-update mode) or 1 (timed-update mode);

    AO_LDAC1_Source_Select = 0 (LDAC1 will output UPDATE) or
                            1 (LDAC1 will output UPDATE2);

    AO_DAC1_Update_Mode = 0 (immediate-update mode) or 1 (timed-update mode);
    AO_Configuration_End = 1;
    End critical section;
}
```

3.6.1.9 Stop On Error

Use this function to set the error conditions upon which the AOTM will stop.

```
Function AO_Errors_To_Stop_On
{
    Begin critical section;
    AO_Configuration_Start = 1;
    AO_Stop_On_BC_TC_Error = 0 (continue on BC_TC error) or
                              1 (stop on BC_TC error);
    AO_Stop_On_BC_TC_Trigger_Error = 0 (continue on BC_TC trigger error) or
                                      1 (stop on BC_TC trigger error);
    AO_Stop_On_Overrun_Error = 0 (continue on overrun error) or
                                1 (stop on overrun error);

    AO_Configuration_End = 1;
    End critical section;
}
```

3.6.1.10 FIFO Mode

Use this function to select the data FIFO condition on which interrupt or DMA requests will be generated, if you want the DAQ-STC to generate them. You can also use this function to program FIFO control for local buffer mode, with or without pauses.

```

Function AO_FIFO
{
    Begin critical section;
    AO_Configuration_Start = 1;
    AO_FIFO_Mode = 0 (generate on empty FIFO) or
                    1 (generate on less than half-full FIFO) or
                    2 (generate on less than full FIFO) or
                    3 (generate on less than half-full FIFO, but keep asserted until
                      FIFO is full);
    AO_FIFO_Retransmit_Enable = 0 (disable local buffer mode) or
                               1 (enable local buffer mode);
    AO_Configuration_End = 1;
    End critical section;
}

```

3.6.1.11 Enable Interrupts

Use this function to enable the AOTM to generate interrupts.

```

Function AO_Interrupt_Install
{
    Begin critical section;
    AO_UPDATE_Interrupt_Enable = 0 (no interrupt) or 1 (generate interrupt);
    AO_BC_TC_Interrupt_Enable = 0 (no interrupt) or 1 (generate interrupt);
    AO_UC_TC_Interrupt_Enable = 0 (no interrupt) or 1 (generate interrupt);
    AO_START1_Interrupt_Enable = 0 (no interrupt) or 1 (generate interrupt);
    AO_Error_Interrupt_Enable = 0 (no interrupt) or 1 (generate interrupt);
    AO_START_Interrupt_Enable = 0 (no interrupt) or 1 (generate interrupt);
    AO_FIFO_Interrupt_Enable = 0 (no interrupt) or 1 (generate interrupt);
    End critical section;
}

```

To generate interrupts, you must also program the interrupt control module. Refer to Chapter 8, *Interrupt Control*, for more information on programming the interrupt control module. To use interrupts, refer to section 3.6.5, *Primary Analog Output Group-Related Interrupts*.

3.6.1.12 Arming

Use this function to arm the analog output counters and to preload the DACs with the first analog output value.

```

Function AO_Arming
{
    Begin critical section;
    AO_Not_An_UPDATE = 1;
}

```

```

Σ
AO_Not_An_UPDATE = 0;
Σ
While AO_TMRDACWRs_In_Progress_St = 1 do
{
No-op;
}
AO_UI_Arm = 1;          /*You must set these three bitfields in a single write*/
AO_UC_Arm = 1;
AO_BC_Arm = 1;
End critical section;
}

```

3.6.1.13 Starting the Waveform

Use the following function to initiate an analog output operation if you have selected software trigger. If you do not select software trigger, this function does not do anything.

```

Function AO_Start_The_Generation
{
    Begin critical section;
    If (software trigger) then
    {
        AO_START1_Pulse = 1;
    }
    End critical section;
}

```

3.6.1.14 Primary Analog Output Program

Use the following sequence of functions to program the AOTM for any primary analog output operation. If you have data FIFO on your board, you should transfer data into that FIFO.

```

{
    /*Refer to section 10.8.1, Programming Clock Distribution, to set up your timebase*/
    Call AO_Reset_All;
    Call AO_Board_Personalize;
    Call AO_Hardware_Gating;
    Call AO_Triggering;
    Call AO_Counting;
    Call AO_Updating;
    Call AO_Channels;
    Call AO_LDAC_Source_And_Update_Mode;
    Call AO_Errors_To_Stop_On;
    Call AO_FIFO;
    Call AO_Interrupt_Install;
}

```

```

    Call AO_Arming;
    Call AO_Start_The_Generation;
}

```

3.6.2 Waveform Staging for Primary Analog Output

Waveform staging can be used to generate timing for a waveform stage consisting of many MISBs. The DAQ-STC has dual-load registers for each analog output counter so that the software can load the parameters for the next MISB while the current MISB is still being output. To accomplish this, program the BC_TC interrupt to call the AO_Staged_ISR ISR. To enable the BC_TC interrupt, you must make sure that an interrupt level is dedicated to the interrupt group B and that interrupt group B is enabled. Program the BC_TC interrupt and interrupt group B as follows:

```

{
    Interrupt_B_Output_Select = 0 through 7;
    Interrupt_B_Enable = 1;
    AO_BC_TC_Interrupt_Enable = 1;
}

```

Interrupts can normally be serviced after some delay, commonly referred to as interrupt latency. In some cases the interrupt latency may be long enough to cause problems in your waveform stage. If the interrupt cannot be serviced during one MISB of the waveform, the DAQ-STC will not be programmed properly for the next MISB. To avoid this, you should keep interrupt latency and workload on your computer system in mind when programming the DAQ-STC for waveform staging. Although the DAQ-STC cannot eliminate the interrupt latency problem, it can detect when an excessive delay has occurred.

Use this function for servicing the BC_TC interrupt during waveform staging. We assume that the parameters for each stage are stored in an array, defined as follows:

```

bc_new_ticks           /*contains the number buffer iterations in each MISB*/
uc_new_ticks           /*contains the number of updates in each buffer of the MISB*/
ui_new_ticks           /*contains the number of clocks between updates in each MISB*/
new_mute_flag          /*indicates whether the MISB will be muted (1 indicates muting)*/

```

In addition, the variable `ao_last_load_register` keeps track of which load registers should be used, and the variable `ao_tick_count_to_use` keeps track of which parameter in the array should be used. These variables were first introduced in the `AO_Counting` function.

Function `AO_Staged_ISR`

```

{
    Declare variables
        new_bc_ticks,           /*number of buffer iterations*/
        new_uc_ticks,           /*number of updates in each buffer*/

```

```

new_ui_ticks,          /*number of clocks between updates*/
new_mute,              /*indicates whether the MISB will be muted*/
ao_shut_down_isr,     /*indicates the last BC_TC in the stage and
                       the next-to-the-last
                       BC_TC in the stage, as follows:
                       2 The last BC_TC
                       1 The next-to-the-last BC_TC
                       0 Otherwise*/
old_stage_uc_ticks;   /*the number up updates in the previous buffer*/
If (ao_shut_down_isr is 2) then
    ao_shut_down_isr = 0;
If (ao_shut_down_isr is 1) then
    ao_shut_down_isr = 2;
new_bc_ticks = bc_new_ticks[ao_tick_count_to_use];
If (new_bc_ticks is 0) then
    ao_shut_down_isr = 1;
If (ao_shut_down_isr is 1) then
{
    AO_End_On_BC_TC = 1;
    ao_tick_count_to_use = 0;
}
new_bc_ticks = bc_new_ticks[ao_tick_count_to_use];
new_uc_ticks = uc_new_ticks[ao_tick_count_to_use];
new_ui_ticks = ui_new_ticks[ao_tick_count_to_use];
new_mute = new_mute_flag[ao_tick_count_to_use];
If (ao_shut_down_isr is 1) then
    new_uc_ticks = new_uc_ticks + 1;
If (ao_shut_down_isr is 2) then
    old_stage_uc_ticks = uc_new_ticks[ao_tick_count_to_use - 1];
If (ao_last_load_register is A) then
{
    AO_BC_Load_B = new_bc_ticks - 1;
    AO_UC_Load_B = new_uc_ticks - 1;
    AO_UI_Load_B = new_ui_ticks - 1;
    AO_Mute_B = new_mute;
    If (ao_shut_down_isr is 2) then
        AO_UC_Load_A = old_stage_uc_ticks - 1;
    ao_last_load_register = B;
}
Else
{
    AO_BC_Load_A = new_bc_ticks - 1;
    AO_UC_Load_A = new_uc_ticks - 1;
    AO_UI_Load_A = new_ui_ticks - 1;
    AO_Mute_A = new_mute;
    If (ao_shut_down_isr is 2) then
        AO_UC_Load_B = old_stage_uc_ticks - 1;
    ao_last_load_register = A;
}

```

```

}
ao_tick_count_to_use = ao_tick_count_to_use + 1;
AO_BC_TC_Interrupt_ack = 1;
If (ao_shut_down_isr is 2) then
{
    /*Check for error between the last BC_TC of one stage and the trigger for the next
    stage*/
    If (AO_BC_TC_Trigger_Error_St is 1) then
    {
        Inform user that a BC_TC trigger error has occurred;
        AO_BC_TC_Trigger_Error_Confirm = 1; /*This is optional*/
    }
}
If (AO_BC_TC_Error_St is 1) then
{
    Inform user that a BC_TC error has occurred;
    /*You need to reprogram analog output circuitry to get things back on track*/
}
}
}

```

3.6.3 Changing Update Rate during an Output Operation for Primary Analog Output Group

Use this function to change the update rate during an output operation if you are not performing waveform staging. The variable `ao_last_load_register` keeps track of which load registers should be used. This variable was first introduced in the `AO_Counting` function.

Function `AO_Rate_Change`

```

{
    Begin critical section;
    If (ao_last_load_register is A)
    {
        If (AO_UI_Next_Load_Source_St is 0) then
        {
            AO_UI_Load_B = number of clocks between updates - 1;
            If (change update rate immediately) then
                AO_UI_Switch_Load_On_TC = 1;
            Else if (change update rate at the end of the current MISB) then
                AO_UI_Switch_Load_On_BC_TC = 1;
            ao_last_load_register = B;
        }
        Else
            Inform user that rate change is impossible at this time;
    }
    Else
    {

```

```

If (AO_UI_Next_Load_Source_St is 1) then
{
    AO_UI_Load_A = number of clocks between updates - 1;
    If (change update rate immediately) then
        AO_UI_Switch_Load_On_TC = 1;
    Else if (change update rate at the end of the current MISB) then
        AO_UI_Switch_Load_On_BC_TC = 1;
        ao_last_load_register = A;
    }
Else
    Inform user that rate change is impossible at this time;
}
End critical section;
}

```

To change the update rate immediately, you must perform at least one update using the previous update interval before a change is possible. The other option is to change the update rate at the end of the current MISB.

3.6.4 Master/Slave Operation Considerations for Primary Analog Output Group

You can use several DAQ-STCs for synchronized analog output operation. To do this, use the RTSI connection to connect the trigger signal to the trigger input of the master DAQ-STC. Also, connect the output equivalent of the trigger from the master DAQ-STC to the slave DAQ-STCs.

You must perform the programming sequence described in section 10.8.1, Programming Clock Distribution, before you execute the sequence given here.

Use this programming sequence:

```

{
    AO_START1_Disable = 1 for the master DAQ-STC;
    AO_Delayed_START1 = 1 for the master DAQ-STC;
    AO_Delayed_START1 = 0 for all the slave DAQ-STCs;
    Perform the usual set-up sequence for each DAQ-STC (see section 3.6.1, Programming for a Primary Analog Output Operation);
    AO_START1_Disable = 0 for the master DAQ-STC;
}

```

3.6.5 Primary Analog Output Group-Related Interrupts

The DAQ-STC is designed to be used primarily with a system that supports interrupts. This section contains instructions on programming the DAQ-STC when it is used in an environment that supports interrupts.

The DAQ-STC you want to program could be a part of a system in which interrupts do not exist. In this case, you can use programming sequences intended for ISRs directly in your application, coupled with the programming technique known as polling. If you use polling, your application must periodically read relevant status bitfields and use the values obtained this way to decide whether to execute programming sequences equivalent to ISRs.

When the DAQ-STC is used in a system in which interrupts can be handled but the handling is prohibitively slow, you can use the polling technique. However, your system will be devoted entirely to one application.

Information on interrupts and polling can be found in the National Instruments Application Note 010: Programming Interrupts for Data Acquisition on 80x86-Based Computers.

Interrupts related to analog output can be generated on the following analog output conditions:

- Error (overrun or overflow)
- STOP (not supported)
- START (not supported)
- START1
- BC_TC
- UC_TC
- FIFO condition
- UPDATE.

Basic actions required to enable, detect, and acknowledge the AO related interrupts follow.

Error

To enable:	AO_Error_Interrupt_Enable
To recognize:	AO_Overrun_St
To acknowledge (and clear):	AO_Error_Interrupt_Ack

STOP (not supported)

To enable:	AO_STOP_Interrupt_Enable
To recognize:	AO_STOP_St
To acknowledge (and clear):	AO_STOP_Interrupt_Ack

START (not supported)

To enable:	AO_START_Interrupt_Enable
To recognize:	AO_START_St
To acknowledge (and clear):	AO_START_Interrupt_Ack

START1

To enable: AO_START1_Interrupt_Enable
 To recognize: AO_START1_St
 To acknowledge (and clear): AO_START1_Interrupt_Ack

BC_TC

To enable: AO_BC_TC_Interrupt_Enable
 To recognize: AO_BC_TC_St
 To acknowledge (and clear): AO_BC_TC_Interrupt_Ack

UC_TC

To enable: AO_UC_TC_Interrupt_Enable
 To recognize: AO_UC_TC_St
 To acknowledge (and clear): AO_UC_TC_Interrupt_Ack

FIFO Condition

To enable: AO_FIFO_Interrupt_Enable
 To select condition use: AO_FIFO_Mode
 To recognize: AO_FIFO_Full_St, AO_FIFO_Half_Full_St, and
 AO_FIFO_Empty_St
 To clear: You must change the FIFO state by dealing with the
 FIFO

UPDATE

To enable: AO_UPDATE_Interrupt_Enable
 To recognize: AO_UPDATE_ST
 To clear: AO_UPDATE_Interrupt_Ack

All interrupts related to analog output are in interrupt group B.

To select the interrupt line to be used:

- Interrupt_B_Output_Select = 0 through 7;
- Interrupt_B_Enable = 1;

To determine quickly if any of the group B interrupts has occurred, use Interrupt_B_St.



Note *The START and STOP interrupts are provided for a mode which is not currently supported. The documentation concerning these interrupts can be ignored.*

To select interrupt output polarity, use Interrupt_Output_Polarity. This selection depends on the board hardware design.

Pass_Through_1_Interrupt is also in interrupt group B.

3.6.6 Programming for a Secondary Analog Output Group Operation

This section contains detailed programming information for bit-level programming of the secondary AOTM for specialized applications. The programs are presented in a bottom-up fashion. This section lists functions that can be used to configure the secondary AOTM for various operations. The functions are then assembled into a complete program in section [3.6.6.9, Secondary Analog Output Program](#).

3.6.6.1 Overview

The DAQ-STC has two groups of counters dedicated to analog output timing and control—the primary group and the secondary group. This section discusses programming for the secondary group. Refer to section [3.6.1, Programming for a Primary Analog Output Operation](#), for a discussion of the primary group.

3.6.6.2 Resetting

Assume the secondary AO module of the DAQ-STC was set up to perform an unknown operation. The object is to stop any activities in progress.

```
Function AO2_Reset_All
{
    Begin critical section;
    AO_UI2_Arm_Disarm = 0;
    AO_UI2_TC_Interrupt_Enable = 0;
    AO_UI2_Source_Select = 0;
    AO_UI2_Source_Polarity = 0;
    AO_UI2_External_Gate_Enable = 0;
    AO_UI2_External_Gate_Select = 0;
    AO_UI2_External_Gate_Polarity = 0;
    AO_UI2_Software_Gate = 0;
    AO_UI2_TC_Interrupt_Ack = 1;
    AO_UI2_TC_Error_Confirm = 1;
    AO_UI2_Initial_Load_Source = 0;
    End critical section;
}
```

You need to perform the `AO2_Board_Personalize` programming function in order to bring secondary analog output module of the DAQ-STC into a known state. You can then program the secondary analog output module for any desired operation.

3.6.6.3 Board Power-up Initialization

Use this function to program software-selectable options in the secondary analog output module of the DAQ-STC that depend on the personality of the board or device the DAQ-STC is on. The options include polarity and pulsewidth of commonly used signals. You must execute this function every time after you invoke the `AO2_Reset_All` function and before you perform any analog output operation using the DAQ-STC. If you are programming a DAQ-STC that is a part of a data acquisition system, refer to the register-level programming manual for information about the proper selections to make in this function.

Function `AO2_Board_Personalize`

```
{
    Begin critical section;
    AO_UPDATE2_Pulse_Timebase = 0 (selected by AO_UPDATE2_Pulse_Width) or
                                1 (selected by AO_UPDATE2_Original_Pulse);
    AO_UPDATE2_Pulse_Width = 0 (3–3.5 AO_OUT_TIMEBASE periods) or
                              1 (1–1.5 AO_OUT_TIMEBASE periods);
    AO_UPDATE2_Original_Pulse = 0 (equal to the pulsewidth of UI2_TC with a
                                   maximum pulsewidth determined by
                                   AO_UPDATE2_Pulse_Width) or
                                1 (equal to the pulsewidth of UI2_TC);
    AO_UPDATE2_Output_Select = 0 (high Z) or 1 (ground) or 2 (enable, active low) or
                                3 (enable, active high);
    End critical section;
}
```

3.6.6.4 Hardware Gate Programming

Use this function to enable or disable hardware and software gating. If you enable hardware gating, you also select the signal that will control the gate, the gate polarity, and the gating mode.

Function `AO2_Hardware_Gating`

```
{
    Begin critical section;
    If (external gating is desired) then
    {
        AO_UI2_External_Gate_Enable = 1;
        AO_UI2_External_Gate_Select = 1 through 10 (PFI<0..9>) or
                                       11 through 17 (RTSI_TRIGGER<0..6>);
        AO_UI2_External_Gate_Polarity = 0 (active high; high enables operation) or
                                       1 (active low; low enables operation);
    }
    Else
        AO_UI2_External_Gate_Enable = 0;
    End critical section;
}
```

3.6.6.5 Software Gate Operation

To use the software gate, issue the following commands:

- To pause secondary analog output:
AO_UI2_Software_Gate = 1;
- To resume secondary AO after pause:
AO_UI2_Software_Gate = 0;



Note *Software and hardware gating can be used simultaneously without any special setup. The secondary analog output operation proceeds when both hardware and software gates are not in the pause state.*

3.6.6.6 Counting for Waveform Staging

Use this function to initialize the counter for waveform staging.

The variable `ao2_tick_count_to_use` introduced in this function will be used later in the waveform staging (`AO2_Staged_ISR`) function.

Function `AO2_Counting`

```
{
  Begin critical section;
  Declare variable
    ao2_tick_count_to_use;          /*Indicates the parameter in the array that
                                     should be used*/
  If (waveform staging) then
    ao2_tick_count_to_use = 1;
  Else
    ao2_tick_count_to_use = 0;
  End critical section;
}
```

3.6.6.7 Update Selection

Use this function to select the update event. For waveform staging operation, it is assumed that the parameters for each stage are stored in an array, defined as follows:

```
ui2_ticks          /*Contains the number of clocks between updates*/
```

The variable `ao2_last_load_register` introduced in this function will be used later in the waveform staging (`AO2_Staged_ISR`) and change update rate during an output operation (`AO2_Rate_Change`).

```

Function AO2_Updating
{
    Begin critical section;
    Declare variable
        ao2_last_load_register;    /*Indicates the load register that was used
                                   previously*/
    AO_UI2_Source_Select = 0 (AO_IN_TIMEBASE1) or 1 through 10 9 (PFI<0..9>) or
        11 through 17 (RTSI_TRIGGER<0..6>) or
        18 (the G_TC signal from general-purpose counter 0) or 1
        9 (the G_TC signal from general-purpose counter 1) or
        20 (IN_TIMEBASE2);
    AO_UI2_Source_Polarity = 0 (rising edge) or 1 (falling edge);
    AO_UI2_Initial_Load_Source = A;
    AO_UI2_Load_A = number of clocks between each update - 1;
    Σ
    AO_UI2_Load = 1;

    If (waveform staging) then
    {
        AO_UI2_Load_B = ui2_ticks[0] - 1;
        AO_UI2_Switch_Load_Next_TC = 1;
        ao2_last_load_register = B;
    }
    Else
        ao2_last_load_register = A;
    End critical section;
}

```

3.6.6.8 Arming

Use this function to arm the UI2 counter.

```

Function AO2_Arming
{
    Begin critical section;
    AO_UI2_Arm_Disarm = 1;
    End critical section;
}

```

3.6.6.9 Secondary Analog Output Program

Use this sequence of functions to program the AOTM for any secondary analog output operation.

```

{
    /*Refer to section 10.8.1, Programming Clock Distribution, to set up your timebase*/
    Call AO2_Reset_All;
}

```

```

    Call AO2_Board_Personalize;
    Call AO2_Hardware_Gating;
    Call AO2_Counting;
    Call AO2_Updating;
    Call AO2_Arming;
}

```

3.6.7 Waveform Staging for Secondary Analog Output

You can use waveform staging to generate timing for a waveform stage consisting of multiple updates, each with a unique update interval. The DAQ-STC has dual load registers for the UI2 counter so that software can load the parameters for the next update interval during the current update interval. To accomplish this, program the UI2_TC interrupt to call the AO2_Staged_ISR ISR.

To enable the UI2_TC interrupt, you must make sure that an interrupt level is dedicated to interrupt group B and that interrupt group B is enabled. You can program the UI2_TC Interrupt and interrupt group B as follows:

```

{
    Interrupt_B_Output_Select = 0 through 7;
    Interrupt_B_Enable = 1;
    AO_UI2_TC_Interrupt_Enable = 1;
}

```

Interrupts can normally be serviced after some delay, commonly referred to as interrupt latency. In some cases the interrupt latency may be long enough to cause problems in your waveform stage. If the interrupt cannot be serviced during one update interval, the DAQ-STC will not be programmed properly for the next update interval. To avoid this, you should keep interrupt latency and workload on your computer system in mind when programming the DAQ-STC for waveform staging. Although the DAQ-STC cannot eliminate the interrupt latency problem, it can detect when an excessive delay has occurred.

Use the following function for servicing the UI2_TC interrupt during waveform staging. It is assumed that the parameters for each stage are stored in an array, defined as follows:

```

ui2_ticks          /*contains the number of clocks between updates*/

```

In addition, the variable `ao2_last_load_register` keeps track of which load registers should be used, and the variable `ao2_tick_count_to_use` keeps track of which parameter in the array should be used. These variables were first introduced in the `AO2_Counting` and `AO2_Updating` functions.

```

Function AO2_Staged_ISR
{
    Declare variable

```

```

new_ticks,          /*Holds the number of clocks between updates*/
ao2_shut_down_isr; /*Indicates the last UI2_TC in the sequence and the
                    next-to-the-last UI2_TC in the sequence, as follows:
                    2 the last UI2_TC
                    1 the next-to-the-last UI2_TC
                    0 otherwise*/

If (ao2_shut_down_isr is 2) then
    AO_UI2_Arm_Disarm = 0;
Else

{
    new_ticks = ui2_ticks[ao2_tick_count_to_use];
    If (new_ticks is 0)
        ao2_shut_down_isr = ao2_shut_down_isr + 1;
    Else
        ao2_tick_count_to_use = ao2_tick_count_to_use + 1;
    If (ao2_last_load_register is A) then
    {
        If (new_ticks is not 0) then
        {
            AO_UI2_Load_B = new_ticks - 1;
            Σ
            AO_UI2_Switch_Load_Next_TC = 1;
        }
        Else
        {
            /*Load maximal count in an attempt to avoid getting an unnecessary UI2
            TC error*/
            AO_UI2_Load_B = 0xFFFF;
            Σ
            AO_UI2_Switch_Load_Next_TC = 1;
        }
        ao2_last_load_register = B;
    }
    Else
    {
        If (new_ticks is not 0) then
        {
            AO_UI2_Load_A new_ticks - 1;
            Σ
            AO_UI2_Switch_Load_Next_TC = 1;
        }
        Else
        {
            AO_UI2_Load_A = 0xFFFF;
            Σ
            AO_UI2_Switch_Load_Next_TC = 1;
        }
    }
}

```

```

        ao2_last_load_register = A;
    }
}
AO_UI2_TC_Interrupt_Ack = 1;
/*Check for interrupt latency problem*/
If (AO_UI2_TC_Error_St is 1) then
{
    Inform user that a UI2_TC error has occurred;
    AO_UI2_TC_Error_Confirm = 1          /*This is optional*/
}
}

```

3.6.8 Changing Update Rate during an Output Operation for Secondary Analog Output

Use this function to change the update rate during an output operation if you are not performing waveform staging. The variable `ao2_last_load_register` keeps track of which load register should be used. This variable was introduced in the `AO2_Updating` function.

```

Function AO2_Rate_Change
{
    If (ao2_last_load_register is A)
    {
        If (AO_UI2_Next_Load_Source_St is 0) then
        {
            AO_UI2_Load_B = number of clocks between updates - 1;
             $\Sigma$ 
            AO_UI2_Switch_Load_Next_TC = 1;
            ao2_last_load_register = B;
        }
    }
    Else
        Inform user that rate change is impossible at this time;
}
Else
{
    If (AO2_UI_Next_Load_Source_St is 1) then
    {
        AO_UI2_Load_A = number of clocks between updates - 1;
         $\Sigma$ 
        AO_UI2_Switch_Load_Next_TC = 1;
        ao2_last_load_register = A;
    }
    Else
        Inform user that rate change is impossible at this time;
}
}
}

```

To change the update rate immediately, you must perform at least one update using the previous update interval before a change is possible.

3.6.9 Master/Slave Operation Considerations for Secondary Analog Output

There are no provisions for master/slave operation of secondary analog output modules on multiple DAQ-STCs. Shared mechanisms, which may require additional external wiring, may be used.

3.6.10 Secondary Analog Output-Related Interrupts

The only interrupts related to AO timing generated by the secondary group are generated on the UI2_TC.

UI2_TC

To enable:	AO_UI2_TC_Interrupt_Enable
To recognize:	AO_UI2_TC_St
To acknowledge (and clear):	AO_UI2_TC_Interrupt_Ack

This interrupt belongs to group B. Refer to section 3.6.5, *Primary Analog Output Group-Related Interrupts*, for more information on programming group B interrupts.

3.6.11 Bitfield Descriptions

Bits in the register bit maps are organized into bitfields. A bitfield can contain one or more bits. Only bits with contiguous locations within a register can belong to a bitfield. The high and low pairs of load and save registers for 24-bit counters are also treated as bitfields. The AOTM-related bitfields are described below. Not all bitfields referred to in section 3.6, *Programming Information*, are listed here. To locate a particular bitfield description within this manual, refer to Appendix B, *Register Information*.

AO_Analog_Trigger_Reset

bit: 15 **type:** Strobe **in:** AO_Command_1_Register **address:** 9

This bit clears the hysteresis registers in the analog trigger circuit. Set this bit to 1 at the time you arm the analog output counters if you want to use analog triggering in hysteresis mode for any analog output signal. Before setting this bit to 1, make sure that the analog trigger is not being used by some other part of the DAQ-STC. This bit should not be set to 1 in any other case. This bit is cleared automatically.

AO_AOFREQ_Enable

bit: 12 **type:** Write **in:** AO_START_Select_Register **address:** 66

This bit enables the AOFREQ output signal:

0: Disabled. The signal is forced to the inactive value (determined by AO_AOFREQ_Polarity).

1: Enabled.

Related bitfields: AO_AOFREQ_Polarity.

AO_AOFREQ_Polarity

bit: 9 **type:** Write **in:** AO_Personal_Register **address:** 78

This bit selects the polarity of the AOFREQ output signal:

0: Active high.

1: Active low.

AO_BC_Arm

bit: 6 **type:** Strobe **in:** AO_Command_1_Register **address:** 9

This bit arms the BC counter. The counter remains armed, and the bit remains set, until it is disarmed either by hardware or by setting AO_Disarm to 1. Related bitfields: AO_BC_Armed_St, AO_Disarm.

AO_BC_Armed_St

bit: 0 **type:** Read **in:** AO_Status_2_Register **address:** 6

This bit indicates whether the BC counter is armed:

0: Disarmed.

1: Armed.

Related bitfields: AO_BC_Arm.

AO_BC_Gate_Enable

bit: 11 **type:** Write **in:** AO_Command_2_Register **address:** 5

This bit enables the BC_GATE:

0: Disabled.

1: Enabled.

Enabling the BC_GATE allows external UPDATE pulses to pass only when the BC counter is enabled to count. You should set this bit to 0 in the internal UPDATE mode (AO_UPDATE_Source_Select is set to 0) and to 1 otherwise. Related bitfields: AO_UPDATE_Source_Select.

AO_BC_Gate_St

bit: 6 **type:** Read **in:** Joint_Status_1_Register **address:** 27

When the BC_GATE is enabled (see AO_BC_Gate_Enable), this bit indicates the state of the BC_GATE:

- 0: Inactive. External UPDATES are blocked.
- 1: Active. External UPDATES are allowed to pass.

The BC_GATE is active only when the BC counter is enabled to count. When the BC_GATE is disabled, this bit is undefined. You must disable the BC_GATE in the internal UPDATE mode. Related bitfields: AO_BC_Gate_Enable.

AO_BC_Initial_Load_Source

bit: 2 **type:** Write **in:** AO_Mode_2_Register **address:** 39

If the BC counter is disarmed, this bit selects the initial BC load register:

- 0: Load register A.
- 1: Load register B.

If the BC counter is armed, writing to this bit has no effect. Related bitfields: AO_BC_Arm.

AO_BC_Load

bit: 5 **type:** Strobe **in:** AO_Command_1_Register **address:** 9

If the BC counter is disarmed, this bit loads the BC counter with the contents of the selected BC load register. If the BC counter is armed, writing to this bit has no effect. This bit is cleared automatically. Related bitfields: AO_BC_Arm, AO_BC_Initial_Load_Source.

AO_BC_Load_A

bits: <0..7> **type:** Write **in:** AO_BC_Load_A_Registers **address:** 44

bits: <0..15> **type:** Write **in:** AO_BC_Load_A_Registers **address:** 45

This bitfield is load register A for the BC counter. If load register A is the selected BC load register, the BC counter loads the value contained in this bitfield on AO_BC_Load and on BC_TC. The eight MSBs are located at the lower address and the 16 LSBs are located at the higher address. Related Bitfields: AO_BC_Next_Load_Source_St, AO_BC_Load.

AO_BC_Load_B

bits: <0..7> **type:** Write **in:** AO_BC_Load_B_Registers **address:** 46

bits: <0..15> **type:** Write **in:** AO_BC_Load_B_Registers **address:** 47

This bitfield is load register B for the BC counter. If load register B is the selected BC load register, the BC counter loads the value contained in this bitfield on AO_BC_Load and on BC_TC. The eight MSBs are located at the lower address and the 16 LSBs are located at the higher address. Related Bitfields: AO_BC_Next_Load_Source_St, AO_BC_Load.

AO_BC_Next_Load_Source_St**bit:** 1 **type:** Read **in:** AO_Status_2_Register **address:** 6

This bit indicates the next load source of the BC counter:

- 0: Load register A.
- 1: Load register B.

**Note** *This bit is updated on counter reload.***AO_BC_Q_St****bit:** 3 **type:** Read **in:** AO_Status_2_Register **address:** 6

This field reflects the state of the BC control circuit:

- 0: WAIT
- 1: CNT

See section 3.8, *Detailed Description*, for more information on the BC control circuit.**AO_BC_Reload_Mode****bit:** 1 **type:** Write **in:** AO_Mode_2_Register **address:** 39

This bit selects the reload mode for the BC counter:

- 0: No automatic change of the BC load register.
- 1: The BC counter will switch load registers on BC_TC.

You can use setting 1 in waveform staging to obtain a new buffer repetition count for each MISB.

AO_BC_Save_St**bit:** 2 **type:** Read **in:** AO_Status_2_Register **address:** 6

This bit indicates the status of the BC save register:

- 0: BC save register is tracing the counter.
- 1: BC save register is latched for later read.

Related bitfields: AO_BC_Save_Trace.

AO_BC_Save_Trace**bit:** 10 **type:** Write **in:** AO_Command_2_Register **address:** 5

Setting this bit to 1 causes the BC save register to latch the BC counter value at the next BC_CLK falling edge. Setting this bit to 0 causes the BC save register to trace the BC counter.

AO_BC_Save_Value**bits:** <0..7> **type:** Read **in:** AO_BC_Save_Registers **address:** 18**bits:** <0..15> **type:** Read **in:** AO_BC_Save_Registers **address:** 19

When AO_BC_Save_Trace is 0, this bitfield reflects the contents of the BC counter. When you set AO_BC_Save_Trace to 1, this bitfield synchronously latches the contents of the BC counter using the BC source. The eight MSBs are located at the lower address and the 16 LSBs are located at the higher address. Related bitfields: AO_BC_Save_Trace.

AO_BC_Source_Select**bit:** 4 **type:** Write **in:** AO_Personal_Register **address:** 78

This bit selects the BC counter source:

0: UPDATE

1: The internal signal UC_TC

You should normally set this bit to 1. Setting 0 is not currently supported.

AO_BC_Switch_Load_On_TC**bit:** 4 **type:** Strobe **in:** AO_Command_2_Register **address:** 5

Setting this bit to 1 causes the BC counter to switch load registers at the next BC_TC. This action is internally synchronized to the falling edge of the BC_CLK. This bit is cleared automatically.

AO_BC_TC_Error_Confirm**bit:** 4 **type:** Strobe **in:** Interrupt_B_Ack_Register **address:** 3

Setting this bit to 1 clears AO_BC_TC_Error_St. This bit is cleared automatically. Related bitfields: AO_BC_TC_Error_St.

AO_BC_TC_Error_St**bit:** 11 **type:** Read **in:** AO_Status_1_Register **address:** 3

This bit indicates the detection of a BC_TC error:

0: No error.

1: Error.

A BC_TC error occurs if AO_BC_TC_Interrupt_Ack is not set between two BC TCs. This allows you to detect large interrupt latencies and potential problems associated with them.

To clear this bit, set AO_BC_TC_Error_Confirm to 1. Related bitfields:

AO_BC_TC_Interrupt_Ack, AO_BC_TC_Error_Confirm.

AO_BC_TC_Interrupt_Ack**bit:** 8 **type:** Strobe **in:** Interrupt_B_Ack_Register **address:** 3

Setting this bit to 1 clears AO_BC_TC_St and acknowledges the BC_TC interrupt request (in either interrupt bank) if the BC_TC interrupt is enabled. This bit is cleared automatically. Related bitfields: AO_BC_TC_St.

AO_BC_TC_Interrupt_Enable**bit:** 0 **type:** Write **in:** Interrupt_B_Enable_Register **address:** 75

This bit enables the BC_TC interrupt:

- 0: Disabled.
- 1: Enabled.

BC_TC interrupts are generated on the trailing edge of BC_TC.

AO_BC_TC_Second_Irq_Enable**bit:** 0 **type:** Write **in:** Second_Irq_B_Enable_Register **address:** 76

This bit enables the BC_TC interrupt in the secondary interrupt bank:

- 0: Disabled.
- 1: Enabled.

BC_TC interrupts are generated on the trailing edge of BC_TC.

AO_BC_TC_St**bit:** 7 **type:** Read **in:** AO_Status_1_Register **address:** 3

This bit indicates whether the BC counter has reached TC:

- 0: No.
- 1: Yes.

This bit is set on the trailing edge of BC_TC. You can clear this bit by setting AO_BC_TC_Interrupt_Ack to 1. Related bitfields: AO_BC_TC_Interrupt_Ack. Refer to Table 8-2, *Interrupt Condition Summary*, for more information.

AO_BC_TC_Trigger_Error_Confirm**bit:** 3 **type:** Strobe **in:** Interrupt_B_Ack_Register **address:** 3

Setting this bit to 1 clears AO_BC_TC_Trigger_Error_St. This bit is cleared automatically. Related bitfields: AO_BC_TC_Trigger_Error_St.

AO_BC_TC_Trigger_Error_St

bit: 4 **type:** Read **in:** AO_Status_2_Register **address:** 6

This bit indicates the detection of a BC_TC trigger error:

- 0: No error.
- 1: Error.

A BC_TC trigger error occurs when a START1 trigger is received after the last BC_TC of a staged waveform but before AO_BC_TC_Interrupt_Ack is set to 1. This allows you to detect triggers which arrive before completion of your ISR. You can clear this bit by setting AO_BC_TC_Trigger_Error_Confirm to 1. Related bitfields: AO_BC_TC_Interrupt_Ack, AO_BC_TC_Trigger_Error_Confirm.

AO_BC_Write_Switch

bit: 0 **type:** Write **in:** AO_Mode_2_Register **address:** 39

This bit enables the write switch feature of the BC load registers. Writes to BC load register A are:

- 0: Unconditionally directed to BC load register A.
- 1: Directed to the inactive BC load register.

AO_Configuration_End

bit: 9 **type:** Strobe **in:** Joint_Reset_Register **address:** 72

This bit clears AO_Configuration_Start, which holds the analog output circuitry in reset to prevent glitches on the output pins during configuration. You should set this bit to 1 at the end of the configuration process of the analog output circuitry (excluding the UI2 counter). This bit is cleared automatically. Related bitfields: AO_Configuration_Start.

AO_Configuration_Start

bit: 5 **type:** Strobe **in:** Joint_Reset_Register **address:** 72

This bit holds the analog output circuitry in reset to prevent glitches on the output pins during configuration. The following analog output circuits are affected:

- output circuits
- counter control circuits
- trigger circuits
- interrupt circuits

The following circuits are also affected:

- Interrupt_B_Ack_Register
- Auto-acknowledge circuit for general-purpose counter 1.

You should set this bit to 1 at the beginning of the configuration process of the analog output circuitry (excluding the UI2 counter). By doing this, you ensure that no spurious glitches appear on the output pins and on the internal circuit components. If you do not set this bit to 1, the DAQ-STC may behave erroneously. You can clear this bit by setting AO_Configuration_End to 1. Related bitfields: AO_Configuration_End.

AO_Continuous

bit: 1 **type:** Write **in:** AO_Mode_1_Register **address:** 38

This bit determines the behavior of the BC, UC, and UI counters during BC_TC:

- 0: Counters will stop on BC_TC.
- 1: Counters will ignore BC_TC. The counters remain armed and generate UPDATE pulses until an AO_End_On_BC_TC or AO_End_On_UC_TC command is given, until the AOTM is reset using AO_Reset, or until an AO_Trigger_Once command is issued.

Related bitfields: AO_End_On_BC_TC, AO_End_On_UC_TC, AO_Reset, AO_Trigger_Once.

AO_DAC_i Update_Mode

i = 0 **bit:** 2 **type:** Write **in:** AO_Command_1_Register **address:** 9

i = 1 **bit:** 4 **type:** Write **in:** AO_Command_1_Register **address:** 9

This bit selects the update mode for the LDAC_i output signals:

- 0: Immediate update mode. LDAC_i outputs an inverted version of the DAC write signals (TMRDACWR and CPUDACWR).
- 1: Timed update mode. LDAC_i outputs the UPDATE or UPDATE2 signal. See AO_LDAC_i_Source_Select.

Related bitfields: AO_LDAC_i_Source_Select.

AO_Delayed_START1

bit: 14 **type:** Write **in:** AO_Trigger_Select_Register **address:** 67

This bit determines when the START1 trigger is used by the AOTM:

- 0: Use the START1 trigger immediately.
- 1: Delay the START1 trigger by synchronizing it to the BC source.

Set this bit to 1 in the master ASIC during master/slave trigger. The slave ASIC can then synchronize to the same clock as the master by triggering on the START1 signal that is output from the master.

AO_Disarm

bit: 13 **type:** Strobe **in:** AO_Command_1_Register **address:** 9

Setting this bit to 1 asynchronously disarms the BC, UC, and UI counters. This command should be used only to disarm idle counters. To disarm non-idle counters, use AO_Software_Reset. This bit is cleared automatically.

AO_DMA_PIO_Control**bit:** 8 **type:** Write **in:** AO_Personal_Register **address:** 78

This bit selects the data interface mode:

- 0: FIFO data interface mode.
- 1: Unbuffered data interface mode.

You should set this bit to 0 on a board with an AO data FIFO. Set this bit to 1 on a board without an AO data FIFO. Refer to section 3.4.3, *Data Interfaces*, for more information on the data interface modes.

AO_End_On_BC_TC**bit:** 15 **type:** Strobe **in:** AO_Command_2_Register **address:** 5

Setting this bit to 1 causes the BC, UC, and UI counters to be stopped but not disarmed at the next BC_TC. You can use this bit to stop waveform generation in the continuous mode so that the AOTM will end up in a retriggerable state. This action is internally synchronized to the falling edge of the UC source. This bit is cleared automatically. Related bitfields: AO_Continuous.

AO_End_On_UC_TC**bit:** 14 **type:** Strobe **in:** AO_Command_2_Register **address:** 5

Setting this bit to 1 causes the BC, UC, and UI counters to be disarmed at the next UC_TC. You can use this bit to stop waveform generation in the continuous mode. This action is internally synchronized to the falling edge of the UC source. This bit is cleared automatically. Related bitfields: AO_Continuous.

AO_Error_Interrupt_Ack**bit:** 13 **type:** Strobe **in:** Interrupt_B_Ack_Register **address:** 3

Setting this bit to 1 clears AO_Overrun_St and acknowledges the Error interrupt request (in either interrupt bank) if the Error interrupt is enabled. This bit is cleared automatically. Related bitfields: AO_Overrun_St.

AO_Error_Interrupt_Enable**bit:** 5 **type:** Write **in:** Interrupt_B_Enable_Register **address:** 75

This bit enables the Error interrupt:

- 0: Disabled.
- 1: Enabled.

The Error interrupt is generated on the detection of an overrun error condition.

AO_Error_Second_Irq_Enable**bit:** 5 **type:** Write **in:** Second_Irq_B_Enable_Register **address:** 76

This bit enables the Error interrupt in the secondary interrupt bank:

- 0: Disabled.
- 1: Enabled.

The Error interrupt is generated on the detection of an overrun error condition.

AO_External_Gate_Enable**bit:** 15 **type:** Write **in:** AO_Output_Control_Register **address:** 86

Setting this bit to 1 enables external gating for the primary analog output group, excluding UI2.

This bit is not supported on the first revision of the DAQ-STC, and must be set to 0. See Appendix D, *DAQ-STC Revision History*, for DAQ-STC revision information.**AO_External_Gate_Polarity****bit:** 3 **type:** Write **in:** AO_Output_Control_Register **address:** 86

This bit selects the polarity of the primary analog output external gate signal:

- 0: Active high (high enables operation).
- 1: Active low (low enables operation).

This bit is not supported on the first revision of the DAQ-STC, and must be set to 0. See Appendix D, *DAQ-STC Revision History*, for DAQ-STC revision information.**AO_External_Gate_Select****bits:** <10..14> **type:** Write **in:** AO_Output_Control_Register **address:** 86

This bit enables and selects the external gate:

- 0: External gate disabled.
- 1–10: PFI<0..9>.
- 11–17: RTSI_TRIGGER<0..6>.
- 31: Logic low.

This bit is not supported on the first revision of the DAQ-STC, and must be set to 0. See Appendix D, *DAQ-STC Revision History*, for DAQ-STC revision information.

AO_External_Gate_St

bit: 11 **type:** Read **in:** Joint_Status_1_Register **address:** 27

This bit indicates whether the external gate and software gate are set to enable waveform generation:

- 0: Pause analog output operation.
- 1: Enable analog output operation.

This bit is not supported on the first revision of the DAQ-STC. See Appendix D, [DAQ-STC Revision History](#) for DAQ-STC revision information.

AO_Fast_CPU

bit: 13 **type:** Write **in:** AO_Personal_Register **address:** 78

This bit determines how long the DAQ-STC deasserts CHRDY_OUT following the assertion of CPUDACREQ during CPU-driven analog output:

- 0: Until the end of CPUDACWR.
- 1: Until the start of CPUDACWR.

Select option 0 for slow CPU interfaces and option 1 for fast CPU interfaces.



Note *This bit also determines how long the DAQ-STC deasserts CHRDY_OUT following the assertion of AOFEF during DAQ-STC-driven analog output in the unbuffered data interface mode.*

AO_FIFO_Empty_St

bit: 12 **type:** Read **in:** AO_Status_1_Register **address:** 3

This bit reflects the state of the AOFEF input signal (after the polarity selection), which indicates the data FIFO status:

- 0: Not empty.
- 1: Empty.

Related bitfields: AO_FIFO_Flags_Polarity.

AO_FIFO_Enable

bit: 10 **type:** Write **in:** AO_Personal_Register **address:** 78

This bit enables the TMRDACWR output signal to generate pulses after each UPDATE:

- 0: Disabled.
- 1: Enabled.

You should set this bit to 0 if there is no data FIFO on your board. In this case, you can use TMRDACWR as a DMA request. Related bitfields: AO_DMA_PIO_Control.

AO_FIFO_Flags_Polarity

bit: 11 **type:** Write **in:** AO_Personal_Register **address:** 78

This bit selects the polarity of the data FIFO flags (input signals AOFFF, AOFHF, and AOFEF):

- 0: Active low.
- 1: Active high.

Related bitfields: AO_FIFO_Full_St, AO_FIFO_Half_Full_St, AO_FIFO_Empty_St.

AO_FIFO_Full_St

bit: 14 **type:** Read **in:** AO_Status_1_Register **address:** 3

This bit reflects the state of the AOFFF input signal (after the polarity selection), which indicates the data FIFO status:

- 0: Not full.
- 1: Full.

Related bitfields: AO_FIFO_Flags_Polarity.

AO_FIFO_Half_Full_St

bit: 13 **type:** Read **in:** AO_Status_1_Register **address:** 3

This bit reflects the state of the AOFHF input signal (after the polarity selection), which indicates the data FIFO status:

- 0: Half-full or less.
- 1: More than half-full.

Related bitfields: AO_FIFO_Flags_Polarity.



Note *The operation of this bit is similar to AI_FIFO_Half_Full_St in the analog input section. In analog input, however, the FIFO requires service when it is MORE than half-full. In analog output, the FIFO requires service when it is HALF FULL OR LESS. For this reason, the analog input and analog output ISRs must check for opposite values when deciding on interrupt servicing.*

AO_FIFO_Interrupt_Enable

bit: 8 **type:** Write **in:** Interrupt_B_Enable_Register **address:** 75

This bit enables the FIFO interrupt:

- 0: Disabled.
- 1: Enabled.

The FIFO interrupt is generated on the FIFO condition indicated by AO_FIFO_Mode.

Related bitfields: AO_FIFO_Mode.

AO_FIFO_Mode**bits:** <14..15> **type:** Write **in:** AO_Mode_2_Register **address:** 39

This bitfield selects the data FIFO condition on which to generate the DMA request (output signal AOFREQ) or FIFO interrupt:

- 0: On empty FIFO.
- 1: On half-full or less FIFO.
- 2: On less than full FIFO.
- 3: Generate on half-full or less FIFO, but keep asserted until FIFO is full.

Related bitfields: AO_FIFO_Interrupt_Enable, AO_FIFO_Second_Irq_Enable, AO_AOFREQ_Enable.

AO_FIFO_Request_St**bit:** 1 **type:** Read **in:** AO_Status_1_Register **address:** 3

This bit indicates the status of the DMA request (output signal AOFREQ) and FIFO interrupt:

- 0: Not asserted.
- 1: Asserted.

AO_FIFO_Mode selects the condition on which to generate the DMA request and FIFO interrupt. Related bitfields: AO_FIFO_Mode.

AO_FIFO_Retransmit_Enable**bit:** 13 **type:** Write **in:** AO_Mode_2_Register **address:** 39

This bit enables the local buffer mode:

- 0: Disabled.
- 1: Enabled.

In the local buffer mode, the contents of the data FIFO are regenerated when the FIFO empties. The AOTM accomplishes this by pulsing the AOFFRT signal when the FIFO empty condition is indicated the AOFEF. You can use the local buffer mode when the FIFO is large enough to hold the whole waveform to be generated and the waveform does not vary in time.

AO_FIFO_Second_Irq_Enable**bit:** 8 **type:** Write **in:** Second_Irq_B_Enable_Register **address:** 76

This bit enables the FIFO interrupt in the secondary interrupt bank:

- 0: Disabled.
- 1: Enabled.

The FIFO interrupt is generated on the FIFO condition indicated by AO_FIFO_Mode. Related bitfields: AO_FIFO_Mode.

AO_Interval_Buffer_Mode

bit: 3 **type:** Write **in:** AO_Personal_Register **address:** 78

This bit enables the insertion of a delay between two buffers:

- 0: Disabled.
- 1: Enabled.

This bitfield is currently not supported, and it must be set to 0.

AO_LDAC_i_Source_Select

i = 0 **bit:** 1 **type:** Write **in:** AO_Command_1_Register **address:** 9

i = 1 **bit:** 3 **type:** Write **in:** AO_Command_1_Register **address:** 9

If AO_DAC_i_Update_Mode is 1, this bit determines the output signal for the pin LDAC_i.

- 0: LDAC_i will output UPDATE.
- 1: LDAC_i will output UPDATE2.

Related bitfields: AO_DAC_i_Update_Mode.

AO_Multiple_Channels

bit: 5 **type:** Write **in:** AO_Mode_1_Register **address:** 38

This bit enables multiple output channel support:

- 0: Disabled.
- 1: Enabled.

Related bitfields: AO_Number_Of_Channels.

AO_Mute_A

bit: 2 **type:** Write **in:** AO_Command_2_Register **address:** 5

This bit determines whether the programmed buffer is a mute buffer:

- 0: Normal buffer.
- 1: Mute buffer.

Set this bit to 0 if you want UPDATE and related signals to be generated while the BC counter is using load register A as the active load register. Set this bit to 1 if you want the DAQ-STC to suppress UPDATE and related signals while the BC counter is using load register A as the active load register. You can use the mute operation to obtain a pause between two real waveforms. You must set the AO_Mute_A bit to the correct value before the BC counter begins using load register A.

AO_Mute_B

bit: 3 **type:** Write **in:** AO_Command_2_Register **address:** 5

This bit determines whether the programmed load register buffer is a mute buffer:

- 0: Normal buffer.
- 1: Mute buffer.

Set this bit to 0 if you want UPDATE and related signals to be generated while the BC counter is using load register B as the active load register. Set this bit to 1 if you want the DAQ-STC to suppress UPDATE and related signals while the BC counter is using load register B as the active load register. You can use the mute operation to obtain a pause between two real waveforms. You must set the AO_Mute_B bit to the correct value before the BC counter begins using load register B.

AO_Not_An_UPDATE

bit: 2 **type:** Write **in:** AO_Mode_3_Register **address:** 70

Setting and then clearing this bit causes the generation of an appropriate number of TMRDACWR pulses without generating any UPDATE pulses. DAC address lines (AO_ADDR<0..3>) will also be affected, if appropriate. You should use this bit during the AO configuration phase in the programming sequence to load the first point of the buffer into the DACs.



Note *For the TMRDACWR pulses to be generated, AO_FIFO_Enable must be set to 1 and the data FIFO must contain data.*

If the analog output section is in external update mode the AO_Overrun_St bit may be set after toggling the AO_Not_An_UPDATE bit high and low. After toggling the AO_Not_An_UPDATE bit, wait for the AO_TMRDACWRs_In_Progress_St bit to be cleared, then set the AO_Error_Interrupt_Ack to clear the AO_Overrun_St bit.

This bit is NOT cleared automatically.

AO_Number_Of_Channels

bits: <6..9> **type:** Write **in:** AO_Output_Control_Register **address:** 86

If AO_Multiple_Channels is set to 1, this bitfield determines the number of analog output channels that will be written:

- 0–15: Output channels 0 through the selected number will be written.

If AO_Multiple_Channels is set to 0, this bitfield determines the number of the single analog output channel that will be written:

- 0–15: Output channel 0-15 will be written.

Related bitfields: AO_Multiple_Channels.

AO_Number_Of_DAC_Packages

bit: 14 **type:** Write **in:** AO_Personal_Register **address:** 78

This bit selects the DAC mode:

- 0: Dual-DAC mode.
- 1: Single-DAC mode.

The pins DACWR<0..1> pulse on each TMRDACWR and CPUDACWR. In the dual-DAC mode, DACWR0 pulses on every write and DACWR1 is not used. In the single-DAC mode, DACWR0 pulses when a write occurs to an even channel and DACWR1 pulses when a write occurs to an odd channel. If you are using the DAQ-STC on a device with two DACs in individual packages, set this bit to 1. When you make this selection, you can use pins DACWR0 and DACWR1. In all other cases, set this bit to 0. When you choose this option, you should use pin DACWR0 only. Refer to section 3.4.2, *DAC Interface*, for more information on DAC modes.

AO_Output_Divide_By_2

bit: 5 **type:** Write **in:** Clock_and_FOUT_Register **address:** 56

This bit determines the frequency of the internal timebase AO_OUT_TIMEBASE:

- 0: Same as IN_TIMEBASE.
- 1: IN_TIMEBASE divided by 2.

AO_Overrun_St

bit: 9 **type:** Read **in:** AO_Status_1_Register **address:** 3

This bit indicates the detection of an overrun error:

- 0: No error.
- 1: Error.

An overrun error occurs when an UPDATE command is issued to a DAC that was not loaded with data. This bit can be cleared by setting AO_Error_Interrupt_Ack to 1. Related bitfields: AO_Error_Interrupt_Ack.



Note *This bit may incorrectly indicate that an error occurred after the end of a waveform generation sequence if there is no more data in the buffer. You can avoid this false error by transferring one more point of data to the board than the waveform generation requires.*

AO_Reset

bit: 1 **type:** Strobe **in:** Joint_Reset_Register **address:** 72

Setting this bit to 1 resets the following registers to their power-on state:

- AO_Command_1_Register
- AO_Command_2_Register
- AO_Interrupt_Control_Register
- AO_Mode_1_Register
- AO_Mode_2_Register

AO_Mode_3_Register
 AO_Output_Control_Register
 AO_Personal_Register
 AO_START_Select_Register
 AO_Trigger_Select_Register

Setting this bit to 1 also clears all of the status bits and interrupts related to analog output, except those associated with the data FIFO. This bit is cleared automatically.

AO_Software_Gate

bit: 1 **type:** Write **in:** AO_Mode_3_Register **address:** 70

This bit controls the software gate, which you can use to pause an analog output operation:

- 0: Enable operation.
- 1: Pause operation.

This bit is not supported on the first revision of the DAQ-STC, and must be set to 0. See Appendix D, [DAQ-STC Revision History](#), for DAQ-STC revision information.

AO_Source_Divide_By_2

bit: 4 **type:** Write **in:** Clock_and_FOUT_Register **address:** 56

This bit determines the frequency of the internal timebase AO_IN_TIMEBASE1:

- 0: Same as IN_TIMEBASE.
- 1: IN_TIMEBASE divided by two.

AO_START_Edge

bit: 5 **type:** Write **in:** AO_START_Select_Register **address:** 66

This bit enables edge detection of the START trigger:

- 0: Disabled.
- 1: Enabled.

This bit is currently not supported, and it must be set to 0.

AO_START_Interrupt_Ack

bit: 11 **type:** Strobe **in:** Interrupt_B_Ack_Register **address:** 3

Setting this bit to 1 clears AO_START_St and acknowledges the START interrupt (in either interrupt bank) if the START interrupt is enabled. This bit is cleared automatically. This bitfield is not currently supported.

AO_START_Interrupt_Enable**bit:** 3 **type:** Write **in:** Interrupt_B_Enable_Register **address:** 75

This bit enables the START interrupt:

- 0: Disabled.
- 1: Enabled.

This bit is currently not supported, and it must be set to 0.

AO_START_Polarity**bit:** 13 **type:** Write **in:** AO_START_Select_Register **address:** 66

This bit determines the polarity of the START trigger:

- 0: Active high or rising edge.
- 1: Active low or falling edge.

This bit is currently not supported, and it must be set to 0.

AO_START_Pulse**bit:** 14 **type:** Strobe **in:** AO_Command_1_Register **address:** 9

Setting this bit to 1 sends a START trigger to the counters if the START software strobe is selected (AO_START_Select is set to 0). This bit is cleared automatically. This bitfield is currently not supported, and it must be set to 0. Related bitfields: AO_START_Select.

AO_START_Second_Irq_Enable**bit:** 3 **type:** Write **in:** Second_Irq_B_Enable_Register **address:** 76

This bit enables the START interrupt in the secondary interrupt bank:

- 0: Disabled.
- 1: Enabled.

This bit is currently not supported, and it must be set to 0.

AO_START_Select**bits:** <0..4> **type:** Write **in:** AO_START_Select_Register **address:** 66

This bitfield selects the START trigger:

- 0: Bitfield AO_START_Pulse or alternate UC_TC.
- 1–10: PFI<0..9>.
- 11–17: RTSI_TRIGGER<0..6>.
- 31: Logic low.

This bitfield is currently not supported, and it must be set to 0.

AO_START_St**bit:** 10 **type:** Read **in:** AO_Status_1_Register **address:** 3

This bit indicates that a valid START signal has been received by the AOTM:

- 0: No.
- 1: Yes.

This bit is currently not supported, and its setting is undefined.

AO_Start_Stop_Gate_Enable**bit:** 13 **type:** Write **in:** AO_Command_2_Register **address:** 5

This bit enables the start/stop gate:

- 0: Disabled.
- 1: Enabled.

This bit is currently not supported, and it must be set to 0.

AO_Start_Stop_Gate_St**bit:** 7 **type:** Read **in:** Joint_Status_1_Register **address:** 27

This bit indicates the status of the start/stop gate, if start/stop gating is enabled.

- 0: Inactive gate.
- 1: Active gate.

This bit is currently not supported, and its setting is undefined.

AO_START_Sync**bit:** 6 **type:** Write **in:** AO_START_Select_Register **address:** 66

This bit enables internal synchronization of the START trigger:

- 0: Disabled.
- 1: Enabled.

This bit is currently not supported, and it must be set to 0.

AO_START1_Disable**bit:** 12 **type:** Write **in:** AO_Mode_2_Register **address:** 39

This bit disables recognition of the START1 trigger:

- 0: Enabled.
- 1: Disabled.

You should use this bit if you want the same START1 trigger to start several activities. First, disable START1 by setting this bit to 1; do the necessary programming on all DAQ-STCs, then enable START1 by setting this bit to 0.

AO_START1_Edge**bit:** 5 **type:** Write **in:** AO_Trigger_Select_Register **address:** 67

This bit enables edge detection of the START1 trigger:

- 0: Disabled.
- 1: Enabled.

This bit should normally be set to 1. Set this bit to 1 if AO_START1_Select is 0. Set this bit to 0 if the ASIC is a START1 slave to another DAQ-STC.

AO_START1_Interrupt_Ack**bit:** 9 **type:** Strobe **in:** Interrupt_B_Ack_Register **address:** 3

Setting this bit to 1 clears AO_START1_St and acknowledges the START1 interrupt request (in either interrupt bank) if the START1 interrupt is enabled. This bit is cleared automatically. Released bitfields: AO_START1_St.

AO_START1_Interrupt_Enable**bit:** 1 **type:** Write **in:** Interrupt_B_Enable_Register **address:** 75

This bit enables the START1 interrupt:

- 0: Disabled.
- 1: Enabled.

The START1 interrupt is generated on valid START1 triggers received by the DAQ-STC. A valid START1 trigger is one that is received while the BC counter is armed and in the WAIT1 state.

AO_START1_Polarity**bit:** 13 **type:** Write **in:** AO_Trigger_Select_Register **address:** 67

This bit determines the polarity of START1 trigger:

- 0: Active high or rising edge.
- 1: Active low or falling edge.

Set this bit to 0 if AO_START1_Select is set to 0.

AO_START1_Pulse**bit:** 0 **type:** Strobe **in:** AO_Command_2_Register **address:** 5

Setting this bit to 1 sends a START1 trigger to the BC, UC, and UI counters if the START1 software strobe is selected (AO_START1_Select is set to 0). This bit is cleared automatically. Related bitfields: AO_START1_Select.

AO_START1_Second_Irq_Enable**bit:** 1 **type:** Write **in:** Second_Irq_B_Enable_Register **address:** 76

This bit enables the START1 interrupt in the secondary interrupt bank:

- 0: Disabled.
- 1: Enabled.

The START1 interrupt is generated on valid START1 triggers received by the DAQ-STC. A valid START1 trigger is one that is received while the BC counter is armed and in the WAIT1 state.

AO_START1_Select**bits:** <0..4> **type:** Write **in:** AO_Trigger_Select_Register **address:** 67

This bitfield selects the START1 trigger:

- 0: Bitfield AO_START1_Pulse.
- 1–10: PFI<0..9>.
- 11–17: RTSI_TRIGGER<0..6>.
- 19: The internal analog input signal START1.
- 31: Logic low.

Related bitfields: AO_START1_Pulse.

AO_START1_St**bit:** 8 **type:** Read **in:** AO_Status_1_Register **address:** 3

This bit indicates that a valid START1 trigger has been received by the DAQ-STC:

- 0: No.
- 1: Yes.

A valid START1 trigger is one that is received while the BC counter is armed and in the WAIT1 state. You can clear this bit by setting AO_START1_Interrupt_Ack to 1. Related bitfields: AO_BC_Arm, AO_START1_Interrupt_Ack. Refer to Table 8-2, *Interrupt Condition Summary*, for more information.

AO_START1_Sync**bit:** 6 **type:** Write **in:** AO_Trigger_Select_Register **address:** 67

This bit enables internal synchronization of the START1 trigger to the BC source:

- 0: Disabled.
- 1: Enabled.

AO_STOP_Interrupt_Ack**bit:** 12 **type:** Strobe **in:** Interrupt_B_Ack_Register **address:** 3

Setting this bit to 1 clears AO_STOP_St and acknowledges the STOP interrupt request (in either interrupt bank) if the STOP interrupt is enabled. This bit is cleared automatically. This bit is currently not supported, and it must be set to 0. Related bitfields: AO_STOP_St.

AO_STOP_Interrupt_Enable**bit:** 4 **type:** Write **in:** Interrupt_B_Enable_Register **address:** 75

This bit enables the STOP interrupt:

- 0: Disabled.
- 1: Enabled.

This bit is currently not supported, and it must be set to 0.

AO_Stop_On_BC_TC_Error**bit:** 3 **type:** Write **in:** AO_Mode_3_Register **address:** 70

This bit determines whether analog output timing will stop when a BC_TC error occurs:

- 0: Continue on BC_TC error.
- 1: Stop on BC_TC error.

AO_BC_TC_Error_St will be set in either case. Related bitfields: AO_BC_TC_Error_St.

AO_Stop_On_BC_TC_Trigger_Error**bit:** 4 **type:** Write **in:** AO_Mode_3_Register **address:** 70

This bit determines whether analog output timing will stop when a BC_TC trigger error occurs:

- 0: Continue on BC_TC trigger error.
- 1: Stop on BC_TC trigger error.

AO_BC_TC_Trigger_Error_St will be set in either case. Related bitfields: AO_BC_TC_Trigger_Error_St.

AO_Stop_On_Overrun_Error**bit:** 5 **type:** Write **in:** AO_Mode_3_Register **address:** 70

This bit determines whether analog output timing will stop when an overrun error occurs. If this bit is set and an overrun error is detected, the update pulses will be masked off until the overrun error is cleared by the AO_Error_Interrupt_Ack bit.

- 0: Continue on overrun error.
- 1: Stop on overrun error.

AO_Overrun_St will be set in either case. Related bitfields: AO_Overrun_St.

**Note**

In the case of maximum rate timing, where the last TMRDACWR is being deasserted at the same time that the next UPDATE is being asserted, the UPDATE pulse may be masked off. Although this is not an error condition, and the AO_Overrun_St bit will not be set, that specific UPDATE pulse may be blocked.

AO_STOP_Second_Irq_Enable**bit:** 4 **type:** Write **in:** Second_Irq_B_Enable_Register **address:** 76

This bit enables the STOP interrupt in the secondary interrupt bank:

- 0: Disabled.
- 1: Enabled.

This bit is currently not supported, and it must be set to 0.

AO_STOP_St**bit:** 2 **type:** Read **in:** Joint_Status_2_Register **address:** 29

This bit indicates that a valid STOP trigger has been received by the AOTM:

- 0: No.
- 1: Yes.

This bit is currently not supported, and its setting is undefined.

AO_TMRDACWRs_In_Progress_St**bit:** 5 **type:** Read **in:** Joint_Status_2_Register **address:** 29

This bit indicates whether the TMRDACWR sequence initiated by an UPDATE or by setting AO_Not_An_UPDATE to 1 has completed:

- 0: Completed.
- 1: n progress.

You can poll this bit if you want to wait on the DAC loading before arming the analog output counters.

AO_TMRDACWR_Pulse_Width**bit:** 12 **type:** Write **in:** AO_Personal_Register **address:** 78

This bit selects the pulsewidth of the TMRDACWR, CPUDACWR, and DACWR<0..1> signals:

- 0: 3 AO_OUT_TIMEBASE periods.
- 1: 2 AO_OUT_TIMEBASE periods.

AO_Trigger_Length**bit:** 11 **type:** Write **in:** AO_Mode_3_Register **address:** 70

This bit selects the signal appearing on the bidirectional pin PFI6/AO_START1 when the pin is configured for output:

- 0: Output the internal signal DA_START1.
- 1: Output the internal signal DA_ST1ED after it has been pulse stretched to be 1–2 AO_OUT_TIMEBASE periods long.

AO_Trigger_Once

bit: 0 **type:** Write **in:** AO_Mode_1_Register **address:** 38

Setting this bit to 1 causes the analog output timing sequence to stop on BC_TC. The BC, UC, and UI counters are disarmed at this time. This bit is cleared automatically.

AO_UC_Arm

bit: 8 **type:** Strobe **in:** AO_Command_1_Register **address:** 9

This bit arms the UC counter. The counter remains armed, and the bit remains set, until it is disarmed either by hardware or by setting AO_Disarm to 1. Related bitfields: AO_UC_Armed_St, AO_Disarm.

AO_UC_Armed_St

bit: 14 **type:** Read **in:** AO_Status_2_Register **address:** 6

This bit indicates whether the UC counter is armed:

0: Disarmed.

1: Armed.

Related bitfields: AO_UC_Arm.

AO_UC_Initial_Load_Source

bit: 11 **type:** Write **in:** AO_Mode_2_Register **address:** 39

If the UC counter is disarmed, this bit selects the initial UC load register:

0: Load register A.

1: Load register B.

If the UC counter is armed, writing to this bit has no effect. Related bitfields: AO_UC_Arm.

AO_UC_Load

bit: 7 **type:** Strobe **in:** AO_Command_1_Register **address:** 9

If the UC counter is disarmed, this bit loads the UC counter with the contents of the selected UC load register (A or B). If the UC counter is armed, writing to this bit has no effect. This bit is cleared automatically. Related bitfields: AO_UC_Initial_Load_Source.

AO_UC_Load_A

bits: <0..7> **type:** Write **in:** AO_UC_Load_A_Registers **address:** 48

bits: <0..15> **type:** Write **in:** AO_UC_Load_A_Registers **address:** 49

This bitfield is load register A for the UC counter. If load register A is the selected UC load register, the UC counter loads the value contained in this bitfield on AO_UC_Load and on UC_TC. The eight MSBs are located at the lower address and the 16 LSBs are located at the higher address. Related bitfields: AO_UC_Next_Load_Source_St, AO_UC_Load.

AO_UC_Load_B

bits: <0..7> **type:** Write **in:** AO_UC_Load_B_Registers **address:** 50

bits: <0..15> **type:** Write **in:** AO_UC_Load_B_Registers **address:** 51

This bitfield is load register B for the UC counter. If load register B is the selected UC load register, the UC counter loads the value contained in this bitfield on AO_UC_Load and on UC_TC. The eight MSBs are located at the lower address and the 16 LSBs are located at the higher address. Related bitfields: AO_UC_Next_Load_Source_St, AO_UC_Load.

AO_UC_Next_Load_Source_St

bit: 15 **type:** Read **in:** AO_Status_2_Register **address:** 6

This bit indicates the next load source of the UC counter:

- 0: Load register A.
- 1: Load register B.

AO_UC_Q_St

bit: 14 **type:** Read **in:** Joint_Status_1_Register **address:** 27

This bit reflects state of the UC control circuit.

- 0: WAIT.
- 1: CNT.

See section 3.8, *Detailed Description*, for more information on the UC control circuit.

AO_UC_Save_St

bit: 7 **type:** Read **in:** AO_Status_2_Register **address:** 6

This bit indicates the status of the UC save register:

- 0: UC save register is tracing the counter.
- 1: UC save register is latched for later read.

AO_UC_Save_Trace

bit: 12 **type:** Write **in:** AO_Command_2_Register **address:** 5

Setting this bit to 1 causes the UC save register to latch the UC counter value at the next UC_CLK falling edge. Setting this bit to 0 causes the UC save register to trace the UC counter.

AO_UC_Save_Value

bits: <0..7> **type:** Write **in:** AO_UC_Save_Registers **address:** 20

bits: <0..15> **type:** Write **in:** AO_UC_Save_Registers **address:** 21

When AO_UC_Save_Trace is 0, this bitfield reflects the contents of the UC counter. When you set AO_UC_Save_Trace to 1, this bitfield synchronously latches the contents of the UC counter using the UC source. The eight MSBs are located at the lower address and the 16 LSBs are located at the higher address. Related bitfields: AO_UC_Save_Trace.

AO_UC_Switch_Load_Every_BC_TC

bit: 12 **type:** Write **in:** AO_Mode_3_Register **address:** 70

This bit enables the UC counter to switch load registers on BC_TC:

0: Disabled.

1: Enabled.

AO_UC_Switch_Load_Every_TC

bit: 2 **type:** Write **in:** AO_Mode_1_Register **address:** 38

This bit enables the UC counter to switch load register on UC_TC:

0: Disabled.

1: Enabled.

AO_UC_Switch_Load_On_BC_TC

bit: 6 **type:** Strobe **in:** AO_Command_2_Register **address:** 5

Setting this bit to 1 causes the UC counter to switch load registers at the next BC_TC. This action is internally synchronized to the falling edge of the UC_CLK. This bit is cleared automatically.

AO_UC_Switch_Load_On_TC

bit: 5 **type:** Strobe **in:** AO_Command_2_Register **address:** 5

Setting this bit to 1 causes the UC counter to switch load registers at the next UC_TC. This action is internally synchronized to the falling edge of the UC_CLK. This bit is cleared automatically.

AO_UC_TC_Interrupt_Ack

bit: 7 **type:** Strobe **in:** Interrupt_B_Ack_Register **address:** 3

Setting this bit to 1 clears AO_UC_TC_St and acknowledges the UC_TC interrupt request (in either interrupt bank) if the UC_TC interrupt is enabled. This bit is cleared automatically. Related bitfields: AO_UC_TC_St.

AO_UC_TC_Interrupt_Enable**bit:** 6 **type:** Write **in:** Interrupt_B_Enable_Register **address:** 75

This bit enables the UC_TC interrupt:

- 0: Disabled.
- 1: Enabled.

UC_TC interrupts are generated on the leading edge of UC_TC.

AO_UC_TC_Second_Irq_Enable**bit:** 6 **type:** Write **in:** Second_Irq_B_Enable_Register **address:** 76

This bit enables the UC_TC interrupt in the secondary interrupt bank:

- 0: Disabled.
- 1: Enabled.

UC_TC interrupts are generated at the leading edge of UC_TC.

AO_UC_TC_St**bit:** 6 **type:** Read **in:** AO_Status_1_Register **address:** 3

This bit indicates whether the UC counter has reached TC:

- 0: No
- 1: Yes.

To clear this bit, set AO_UC_TC_Interrupt_Ack to 1. Related bitfields:

AO_UC_TC_Interrupt_Ack. Refer to Table 8-2, [Interrupt Condition Summary](#), for more information.**AO_UC_Write_Switch****bit:** 10 **type:** Write **in:** AO_Mode_2_Register **address:** 39

This bit enables the write switch feature of the UC load registers. Writes to UC load register A are:

- 0: Unconditionally directed to UC load register A.
- 1: Directed to the inactive UC load register.

AO_UI_Arm**bit:** 10 **type:** Strobe **in:** AO_Command_1_Register **address:** 9

Setting this bit to 1 arms the UI counter. The counter remains armed, and the bit remains set, until it is disarmed either by hardware or by setting AO_Disarm to 1. Related bitfields: AO_UI_Arm, AO_Disarm.

AO_UI_Armed_St

bit: 5 **type:** Read **in:** AO_Status_2_Register **address:** 6

This bit indicates whether the UI counter is armed:

- 0: Disarmed.
- 1: Armed.

Related bitfields: AO_UI_Arm.

AO_UI_Count_Enabled_St

bit: 8 **type:** Read **in:** AO_Status_2_Register **address:** 6

If the UI counter is armed, this bit indicates whether the UI counter is enabled to count:

- 0: No.
- 1: Yes.

If the counter is disarmed, this bit should be ignored.

AO_UI_Initial_Load_Source

bit: 7 **type:** Write **in:** AO_Mode_2_Register **address:** 39

If the UI counter is disarmed, this bit selects the initial UI load register:

- 0: Load register A.
- 1: Load register B.

If the UI counter is armed, writing to this bit has no effect. Related bitfields: AO_UI_Arm.

AO_UI_Load

bit: 9 **type:** Strobe **in:** AO_Command_1_Register **address:** 9

If the UI counter is disarmed, this bit loads the UI counter with the contents of the selected UI load register (A or B). If the UI counter is armed, writing to this bit has no effect. This bit is cleared automatically.

AO_UI_Load_A

bits: <0..7> **type:** Write **in:** AO_UI_Load_A_Registers **address:** 40

bits: <0..15> **type:** Write **in:** AO_UI_Load_A_Registers **address:** 41

This bitfield is load register A for the UI counter. If load register A is the selected UI load register, the UI counter loads the value contained in this bitfield on AO_UI_Load and on UI_TC. The eight MSBs are located at the lower address and the 16 LSBs are located at the higher address. Related bitfields: AO_UI_Next_Load_Source_St, AO_UI_Load.

AO_UI_Load_B**bits:** <0..7> **type:** Write **in:** AO_UI_Load_B_Registers **address:** 42**bits:** <0..15> **type:** Write **in:** AO_UI_Load_B_Registers **address:** 43

This bitfield is load register B for the UI counter. If load register B is the selected UI load register, the UI counter loads the value contained in this bitfield on AO_UI_Load and on UI_TC. The eight MSBs are located at the lower address and the 16 LSBs are located at the higher address. Related bitfields: AO_UI_Next_Load_Source_St, AO_UI_Load.

AO_UI_Next_Load_Source_St**bit:** 6 **type:** Read **in:** AO_Status_2_Register **address:** 6

This bit indicates the next load source of the UI counter:

- 0: Load register A.
- 1: Load register B.

AO_UI_Q_St**bit:** 9 **type:** Read **in:** AO_Status_2_Register **address:** 6

This field reflects the state of the UI control circuit:

- 0: WAIT.
- 1: CNT.

See section 3.8, *Detailed Description*, for more information on the UI control circuit.

AO_UI_Reload_Mode**bits:** <4..6> **type:** Write **in:** AO_Mode_2_Register **address:** 39

This bitfield selects the reload mode for the UI counter:

- 0: No automatic change of the UI load register.
- 4: Alternate first period on STOP. Use this setting to make the time interval between the START trigger and the first UPDATE pulse different from the remaining update intervals.
- 5: Switch load register on STOP. Use this setting to synchronously change the update interval at each STOP.
- 6: Alternate first period on BC_TC. Use this setting to make the time interval between the START1 trigger and the first UPDATE pulse different from the remaining update intervals.
- 7: Switch load register on BC_TC. Use this setting to synchronously change the update interval at each BC_TC. This is convenient for staged analog output operation.

AO_UI_Save_Value

bits: <0..7> **type:** Read **in:** AO_UI_Save_Registers **address:** 16

bits: <0..15> **type:** Read **in:** AO_UI_Save_Registers **address:** 17

This bitfield reflects the contents of the UI counter. Reading from this bitfield while the UI counter is counting may result in an erroneous value. The eight MSBs are located at the lower address and the 16 LSBs are located at the higher address.

AO_UI_Source_Polarity

bit: 3 **type:** Write **in:** AO_Mode_1_Register **address:** 38

This bit selects the active edge of the UI source (the signal that is selected by AO_UI_Source_Select):

0: Rising edge.

1: Falling edge.

Related bitfields: AI_UI_Source_Select.

AO_UI_Source_Select

bits: <6..10> **type:** Write **in:** AO_Mode_1_Register **address:** 38

This bitfields selects the UI source:

0: The internal signal AO_IN_TIMEBASE1.

1–10: PFI<0..9>.

11–17: RTSI_TRIGGER<0..6>.

19: The internal signal IN_TIMEBASE2.

31: Logic low.

Related bitfields: AO_UI_Source_Polarity.

AO_UI_Switch_Load_On_BC_TC

bit: 9 **type:** Strobe **in:** AO_Command_2_Register **address:** 5

Setting this bit to 1 causes the UI counter to switch load registers at the next BC_TC. This action is internally synchronized to the falling edge of the UI_CLK. You can use this bit to change the update rate during waveform generation at the end of the current MISB. This bit is cleared automatically.

AO_UI_Switch_Load_On_Stop

bit: 8 **type:** Strobe **in:** AO_Command_2_Register **address:** 5

Setting this bit to 1 causes the UI counter to switch load registers upon receiving a STOP trigger. This action is internally synchronized to the falling edge of the UI_CLK. This bit is cleared automatically. This bitfield is currently not supported, and it must be set to 0.

AO_UI_Switch_Load_On_TC**bit:** 7 **type:** Strobe **in:** AO_Command_2_Register **address:** 5

Setting this bit to 1 causes the UI counter to switch the load registers at the next UI_TC. This action is internally synchronized to the falling edge of the UI_CLK. You can use this bit to change the update rate during waveform generation at the end of the current buffer. This bit is cleared automatically.

AO_UI_Write_Switch**bit:** 3 **type:** Write **in:** AO_Mode_2_Register **address:** 39

This bit enables the write switch feature of the UI load registers. Writes to UI load register A are:

- 0: Unconditionally directed to the UI load register A.
- 1: Directed to the inactive UI load register.

AO_UI2_Arm_Disarm**bit:** 12 **type:** Write **in:** AO_Command_1_Register **address:** 9

Setting this bit to 1 arms the UI2 counter. Setting this bit to 0 disarms the UI2 counter.

AO_UI2_Armed_St**bit:** 11 **type:** Read **in:** AO_Status_2_Register **address:** 6

This bit indicates whether the UI2 counter is armed:

- 0: Disarmed.
- 1: Armed.

AO_UI2_Configuration_End**bit:** 10 **type:** Strobe **in:** Joint_Reset_Register **address:** 72

This bit clears AO_UI2_Configuration_Start, which holds the secondary analog output circuitry in reset to prevent glitches on the output pins during configuration. You should set this bit to 1 at the end of the UI2 counter configuration process. This bit is cleared automatically. Related bitfields: AO_UI2_Configuration_Start.

AO_UI2_Configuration_Start**bit:** 6 **type:** Strobe **in:** Joint_Reset_Register **address:** 72

This bit holds the secondary analog output circuitry in reset to prevent glitches on the output pins during configuration. You should set this bit to 1 at the beginning of the UI2 counter configuration process. By doing this, you ensure that no spurious glitches appear on the output pins and on the internal circuit components. If you do not set this bit to 1, the DAQ-STC may behave erroneously. You can clear this bit by setting AO_UI2_Configuration_End to 1. Related bitfields: AO_UI2_Configuration_End.

AO_UI2_Count_Enabled_St**bit:** 13 **type:** Read **in:** AO_Status_2_Register **address:** 6

If the UI2 counter is armed, this bit indicates whether the UI2 counter is counting:

- 0: No.
- 1: Yes.

If the counter is not armed, this bit should be ignored.

AO_UI2_External_Gate_Enable**bit:** 15 **type:** Write **in:** AO_Trigger_Select_Register **address:** 67

This bit enables the secondary external gate:

- 0: Disabled.
- 1: Enabled.

AO_UI2_External_Gate_Polarity**bit:** 14 **type:** Write **in:** AO_START_Select_Register **address:** 66

This bit selects the polarity of the secondary external gate:

- 0: Active high (high enables counting).
- 1: Active low (low enables counting).

AO_UI2_External_Gate_Select**bits:** <7..11> **type:** Write **in:** AO_START_Select_Register **address:** 66

This bit selects the secondary external gate if the secondary external gate is enabled:

- 1–10: PFI<0..9>.
- 11–17: RTSI_TRIGGER<0..6>.
- 31: Logic low.

Related bitfields: AO_UI2_External_Gate_Enable.

AO_UI2_Gate_St**bit:** 13 **type:** Read **in:** Joint_Status_1_Register **address:** 27

This bit reflects the state of the secondary external gate. The secondary external gate is set to:

- 0: Pause the UI2 counter.
- 1: Enable the UI2 counter.

AO_UI2_Initial_Load_Source**bit:** 9 **type:** Write **in:** AO_Mode_2_Register **address:** 39

If the UI2 counter is disarmed, this bit selects the initial UI2 load register:

- 0: Load register A.
- 1: Load register B.

If the UI2 counter is armed, writing to this bit has no effect. Related bitfields: AO_UI2_Arm.

AO_UI2_Load

bit: 11 **type:** Strobe **in:** AO_Command_1_Register **address:** 9

If the UI2 counter is disarmed, this bit loads the UI2 counter with the contents of the selected UI2 load register (A or B). If the UI2 counter is armed, writing to this bit has no effect. This bit is cleared automatically. Related bitfields: AI_UI2_Initial_Load_Source.

AO_UI2_Load_A

bits: <0..15> **type:** Write **in:** AO_UI2_Load_A_Register **address:** 53

This bitfield is load register A for the UI2 counter. If load register A is the selected UI2 load register, the UI2 counter loads the value contained in this bitfield on AO_UI2_Load and on UI2_TC. Related bitfields: AO_UI2_Next_Load_Source_St, AO_UI2_Load.

AO_UI2_Load_B

bits: <0..15> **type:** Write **in:** AO_UI2_Load_B_Register **address:** 55

This bitfield is load register B for the UI2 counter. If load register B is the selected UI2 load register, the UI2 counter loads the value contained in this bitfield on AO_UI2_Load and on UI2_TC. Related bitfields: AO_UI2_Next_Load_Source_St, AO_UI2_Load.

AO_UI2_Next_Load_Source_St

bit: 12 **type:** Read **in:** AO_Status_2_Register **address:** 6

This bit indicates the next load source of the UI2 counter:

- 0: Load register A.
- 1: Load register B.

AO_UI2_Reload_Mode

bit: 8 **type:** Write **in:** AO_Mode_2_Register **address:** 39

This bit selects the reload mode for the UI2 counter:

- 0: No automatic change of the UI2 load register.
- 1: The UI2 counter will switch load registers on every UI2_TC.

AO_UI2_Save_Value

bits: <0..15> **type:** Read **in:** AO_UI2_Save_Register **address:** 23

This bitfield reflects the contents of the UI2 counter. Reading from this bitfield while the UI2 counter is counting may result in an erroneous value.

AO_UI2_Software_Gate**bit:** 15 **type:** Write **in:** AO_START_Select_Register **address:** 66

Setting this bit to 1 stops the UI2 counter immediately. Setting this bit to 0 allows the UI2 counter to count.

AO_UI2_Source_Polarity**bit:** 12 **type:** Write **in:** AO_Trigger_Select_Register **address:** 67

This bit selects the active edge of the UI2 source (the signal that is selected by AO_UI2_Source_Select):

- 0: Rising edge.
- 1: Falling edge.

Related bitfields: AO_UI2_Source_Select.

AO_UI2_Source_Select**bits:** <7..11> **type:** Write **in:** AO_Trigger_Select_Register **address:** 67

This bit selects the UI2 source:

- 0: The internal signal AO_IN_TIMBASE1.
- 1–10: PFI<0..9>.
- 11–17: RTSI_TRIGGER<0..6>.
- 18: The internal G_TC signal from general-purpose counter 0.
- 19: The internal G_TC signal from general-purpose counter 1.
- 20: The internal signal IN_TIMEBASE2.
- 31: Logic low.

AO_UI2_Switch_Load_Next_TC**bit:** 13 **type:** Strobe **in:** AO_Mode_3_Register **address:** 70

Setting this bit to 1 causes the UI2 counter to switch load registers at the next UI2_TC. This bit is cleared automatically.

AO_UI2_TC_Error_Confirm**bit:** 5 **type:** Strobe **in:** Interrupt_B_Ack_Register **address:** 3

Setting this bit to 1 clears AO_UI2_TC_Error_St. This bit is cleared automatically. Related bitfields: AO_UI2_Error_St.

AO_UI2_TC_Error_St**bit:** 10 **type:** Read **in:** AO_Status_2_Register **address:** 6

This bit indicates the detection of a UI2_TC error:

- 0: No error.
- 1: Error.

A UI2_TC error occurs if AO_UI2_TC_Interrupt_Ack is not set between two UI2 TCs. This allows you to detect interrupt latencies and potential problems associated with them. To clear this bit, set AO_UI2_TC_Error_Confirm to 1. Related bitfields: AO_UI2_TC_Interrupt_Ack, AO_UI2_TC_Error_Confirm.

AO_UI2_TC_Interrupt_Ack**bit:** 6 **type:** Strobe **in:** Interrupt_B_Ack_Register **address:** 3

Setting this bit to 1 clears AO_UI2_TC_St and acknowledges the UI2_TC interrupt request (in either interrupt bank) if the UI2_TC interrupt is enabled. This bit is cleared automatically. Related bitfields: AO_UI2_TC_St.

AO_UI2_TC_Interrupt_Enable**bit:** 7 **type:** Write **in:** Interrupt_B_Enable_Register **address:** 75

This bit enables the UI2_TC interrupt:

- 0: Disabled.
- 1: Enabled.

UI2_TC interrupts are generated on the trailing edge of UPDATE2.

AO_UI2_TC_Second_Irq_Enable**bit:** 7 **type:** Write **in:** Second_Irq_B_Enable_Register **address:** 76

This bit enables the UI2_TC interrupt in the secondary interrupt bank:

- 0: Disabled.
- 1: Enabled.

UI2_TC interrupts are generated on the trailing edge of UPDATE2.

AO_UI2_TC_St**bit:** 4 **type:** Read **in:** AO_Status_1_Register **address:** 3

This bit indicates whether the UI2 counter has reached TC:

- 0: No.
- 1: Yes.

To clear this bit, set AO_UI2_TC_Interrupt_Ack to 1. Related bitfields: AO_UI2_TC_Interrupt_Ack. Refer to Table 8-2, *Interrupt Condition Summary*, for more information.

AO_UPDATE2_Original_Pulse

bit: 2 **type:** Write **in:** AO_Personal_Register **address:** 78

If AO_UPDATE2_Pulse_Timebase is 1, this bit determines the pulsewidth of the UPDATE2 signal. The pulsewidth of the UPDATE2 signal will be:

- 0: Equal to the pulsewidth of UI2_TC, with the maximum pulsewidth determined by AO_UPDATE2_Pulse_Width.
- 1: Equal to the pulsewidth of UI2_TC.

If this bit is set to 1, external gating for the UI2 counter will not work. Related bitfields: AO_UPDATE2_Pulse_Timebase, AO_UPDATE2_Pulse_Width.

AO_UPDATE2_Output_Select

bits: <4..5> **type:** Write **in:** AO_Output_Control_Register **address:** 86

This bit enables and selects the polarity of the UPDATE2 output signal:

- 0: High Z.
- 1: Ground.
- 2: Enable, active low.
- 3: Enable, active high.

AO_UPDATE2_Output_Toggle

bit: 2 **type:** Write **in:** AO_Output_Control_Register **address:** 86

This bit determines the behavior of the internal UI2_TC signal sent to the general-purpose counter gate selection circuits:

- 0: Same as UI2_TC.
- 1: Toggle on every UI2_TC.

Related bitfields: Gi_Gate_Select.

AO_UPDATE2_Pulse

bit: 1 **type:** Strobe **in:** AO_Command_2_Register **address:** 5

Setting this bit to 1 produces a pulse on the UPDATE2 output signal, if the output is enabled and if UPDATE2 pulses are not blocked. UPDATE2 pulses can be blocked by the secondary external gate or by AO_UI2_Software_Gate. The pulsewidth of the output signal is determined by AO_UPDATE2_Pulse_Width. This bit is cleared automatically. Related bitfields: AO_UI2_Software_Gate, AO_UPDATE2_Pulse_Width.

AO_UPDATE2_Pulse_Timebase**bit:** 1 **type:** Write **in:** AO_Personal_Register **address:** 78

This bit determines how the pulsewidth of the UPDATE2 output signal is selected:

- 0: Selected by AO_UPDATE2_Pulse_Width.
- 1: Selected by AO_UPDATE2_Original_Pulse.

This bit is cleared automatically. Related bitfields: AO_UI2_Pulse_Width, AO_UI2_Original_Pulse.

AO_UPDATE2_Pulse_Width**bit:** 0 **type:** Write **in:** AO_Personal_Register **address:** 78

If AO_UPDATE2_Pulse_Timebase is 0, this bit determines the pulsewidth of the UPDATE2 signal. If AO_UPDATE2_Pulse_Timebase is 1 and AO_UPDATE2_Original_Pulse is 0, this bitfield setting determines the maximal pulsewidth of the UPDATE2 signal (so that the pulsewidth is equal to the shorter of this pulsewidth and the original signal pulsewidth). The UPDATE2 signal pulsewidth is:

- 0: 3–3.5 AO_OUT_TIMEBASE periods.
- 1: 1–1.5 AO_OUT_TIMEBASE periods.

Related bitfields: AO_UI2_Pulse_Timebase, AO_UI2_Original_Pulse.

AO_UPDATE_Interrupt_Ack**bit:** 10 **type:** Strobe **in:** Interrupt_B_Ack_Register **address:** 3

Setting this bit to 1 clears AO_UPDATE_St and acknowledges the UPDATE interrupt request (in either interrupt bank) if the UPDATE interrupt is enable. This bit is cleared automatically. Related bitfields: AO_UPDATE_St.

AO_UPDATE_Interrupt_Enable**bit:** 2 **type:** Write **in:** Interrupt_B_Enable_Register **address:** 75

This bit enables the UPDATE interrupt:

- 0: Disabled.
- 1: Enabled.

UPDATE interrupts are generated on the trailing edge of UPDATE.

AO_UPDATE_Original_Pulse**bit:** 7 **type:** Write **in:** AO_Personal_Register **address:** 78

If AO_UPDATE_Pulse_Timebase is 1, this bit determines the pulsewidth of the UPDATE signal. The pulsewidth of the UPDATE signal is:

- 0: Equal to the pulsewidth of the signal used to generate the UPDATE signal, with the maximum pulsewidth determined by AI_UPDATE_Pulse_Width.
- 1: Equal to the pulsewidth of the signal used to generate the UPDATE signal.

If you set this bit to 1, external gating for the analog output circuitry (except the UI2 counter) will not work. Related bitfields: AO_UPDATE_Pulse_Timebase, AO_UPDATE_Pulse_Width, AO_UPDATE_Source_Select.

AO_UPDATE_Output_Select**bits:** <0..1> **type:** Write **in:** AO_Output_Control_Register **address:** 86

This bitfield enables and selects the polarity of the UPDATE output signal:

- 0: High Z.
- 1: Ground.
- 2: Enable, active low.
- 3: Enable, active high.

This bitfield also selects the polarity of the PFI5/UPDATE output signal, if enabled for output:

- 0: Active low.
- 1: Ground.
- 2: Active low.
- 3: Active high.

Related bitfields: BD_5_Pin_Dir.

AO_UPDATE_Pulse**bit:** 0 **type:** Strobe **in:** AO_Command_1_Register **address:** 9

Setting this bit to 1 produces a pulse on the UPDATE and PFI5/UPDATE output signals if the signals are enabled for output and if UPDATE pulses are not blocked. UPDATE pulses can be blocked by the external gate or by AO_Software_Gate. The pulsewidth of the output signals is determined by AO_UPDATE_Pulse_Width. This bit is cleared automatically.

Related bitfields: AO_UPDATE_Output_Select, AO_Software_Gate, AO_UPDATE_Pulse_Width.

AO_UPDATE_Pulse_Timebase**bit:** 6 **type:** Write **in:** AO_Personal_Register **address:** 78

This bit determines how the pulsewidth of the UPDATE and PFI5/UPDATE signal is selected:

- 0: Selected by AO_UPDATE_Pulse_Width.
- 1: Selected by AO_UPDATE_Original_Pulse.

Related bitfields: AO_UPDATE_Pulse_Width, AO_UPDATE_Original_Pulse.

AO_UPDATE_Pulse_Width**bit:** 5 **type:** Write **in:** AO_Personal_Register **address:** 78

If AO_UPDATE_Pulse_Timebase is 0, this bit determines the pulsewidth of the UPDATE and PFI5/UPDATE signals. If AO_UPDATE_Pulse_Timebase is 1 and AO_UPDATE_Original_Pulse is 0, this bit determines the maximum pulsewidth of the UPDATE and PFI5/UPDATE signals (so that the pulsewidth is equal to the shorter of this pulsewidth and the original signal pulsewidth). The pulsewidths are as follows:

- 0: 3–3.5 AO_OUT_TIMEBASE periods.
- 1: 1–1.5 AO_OUT_TIMEBASE periods.

AO_UPDATE_Second_Irq_Enable**bit:** 2 **type:** Write **in:** Second_Irq_B_Enable_Register **address:** 76

This bit enables the UPDATE interrupt in the secondary interrupt bank:

- 0: Disabled.
- 1: Enabled.

UPDATE interrupts are generated on the trailing edge of UPDATE.

AO_UPDATE_Source_Polarity**bit:** 4 **type:** Write **in:** AO_Mode_1_Register **address:** 38

This bit selects the active edge of the UPDATE source (the signal that is selected by AO_UPDATE_Source_Select):

- 0: Rising edge.
- 1: Falling edge.

You must set this bit to 0 in the internal UPDATE mode. Related bitfields: AO_UPDATE_Source_Select.

AO_UPDATE_Source_Select**bits:** <11..15> **type:** Write **in:** AO_Mode_1_Register **address:** 38

This bitfield selects the UPDATE source:

- 0: The internal signal UI_TC.
- 1–10: PFI<0..9>.
- 11–17: RTSI_TRIGGER<0..6>.
- 19: The internal GOUT signal from general-purpose counter 1.
- 31: Logic low.

When you set this bit to 0, the DAQ-STC is in the internal UPDATE mode. When you select any other signal as the UPDATE source, the DAQ-STC is in the external UPDATE mode.

AO_UPDATE_St**bit:** 5 **type:** Read **in:** AO_Status_1_Register **address:** 3

This bit indicates whether an UPDATE has occurred:

- 0: Has not occurred.
- 1: Has occurred.

You can clear this bit by setting AO_UPDATE_Interrupt_Ack to 1. Related bitfields: AO_UPDATE_Interrupt_Ack. Refer to Table 8-2, *Interrupt Condition Summary*, for more information.

3.7 Timing Diagrams

The DAQ-STC is primarily a synchronous device and requires careful inspection of the timing parameters when designing a new board. Related subsections within the chip can be programmed to operate at different clock rates, and the necessary synchronization time can significantly affect the edges and pulsewidths of the board-level signals. There are certain configurations of the clock rates that offer very straightforward timing signals, and it is intended that these settings be used for the majority of the DAQ-STC designs. The other modes are included to provide flexibility for unusual or currently unanticipated applications.

This section includes all of the timing diagrams for the AOTM module of the DAQ-STC and indicates the more common configurations.

3.7.1 Signal Definitions

All timing in this section refers to pin-to-pin timing. Since many of the timing parameters are defined based on internal signals, and the internal signals can be selected from a variety of sources, it is convenient to define some global signals that can refer to any one of a number of pins depending on the internal signal selection.

Some of the tables in this section indicate that OSC is the reference pin, with RTSI_OSC included in parentheses. This indicates that you can use RTSI_Clock_Mode to choose between OSC and RTSI_OSC as the reference pin.

3.7.1.1 UPDATE_SRC

UPDATE_SRC represents the signal that causes an UPDATE to be generated. Table 3-2 indicates the pin represented by UPDATE_SRC based on internal selection.

Table 3-2. UPDATE_SRC Reference Pin Selection

AO_UPDATE_Source_Select	Reference Pin
0	The UPDATE source is selected to be UI_TC. The reference pin is determined by AI_UI_Source_Select.
1–10	PFI<0..9>
11–17	RTSI_TRIGGER<0..6>
19	The UPDATE source is selected to be the output of general-purpose counter 1. The reference pin is determined by G1_Source_Select. To determine delays for this case, the source to output delay (T _{so}) from general-purpose counter 1 must be added.

3.7.1.1 UI2_SRC

UI2_SRC represents the signal that clocks the UI2 counter. Table 3-3 indicates the pin represented by UI2_SRC based on internal selection.

Table 3-3. UI2_SRC Reference Pin Selection

AO_UI2_Source_Select	Reference Pin
0	The reference pin is OSC or RTSI_OSC, depending on the clock mode you choose in RTSI_Clock mode.
1–10	PFI<0..9>
11–17	RTSI_TRIGGER<0..6>
19	The UI2 source is selected to be the output of general-purpose counter 0. The reference pin is determined by G0_Source_Select. To determine delays for this case, the source to output delay (T _{so}) from general-purpose counter 0 must be added.

Table 3-3. UI2_SRC Reference Pin Selection (Continued)

AO_UI2_Source_Select	Reference Pin
20	The UI2 source is selected to be the output of general-purpose counter 1. The reference pin is determined by G1_Source_Select. To determine delays for this case, the source to output delay (T _{so}) from general-purpose counter 1 must be added.
21	The reference pin is OSC or RTSI_OSC, depending on the clock mode you choose in RTSI_Clock mode.

3.7.1.1 OUT_CLK

OUT_CLK represents the AO_OUT_TIMEBASE signal, which can come from the OSC input or the RTSI_OSC input, respectively, depending on the clock mode you choose in RTSI_Clock mode. If the output clock is set for divide by two operation, then each edge of OUT_CLK represents a rising edge of OSC (or RTSI_OSC). Otherwise, OUT_CLK and OSC (or RTSI_OSC) are identical.

3.7.2 DAQ-STC-Driven Analog Output Timing

The basic analog output functionality provided by the DAQ-STC can control the timed updating of up to 16 independent, double-buffered DACs fed by a single FIFO. The primary output signals are UPDATE, TMRDACWR, AO_ADDR<0..3>, TMRDACREQ, and AOFREQ, and the input signals are AOFFF, AOFHF, and AOFEF. Figure 3-14 shows the timing for these signals in a basic analog output sequence. There are two UPDATE signals shown, UPDATE(SRC) and UPDATE(OUT). The UPDATE signal can be operated from either the source or output clocks, and both are included in the timing diagram.

When there is data in the FIFO, the TMRDACREQ signal is removed and TMRDACWR is asserted. The delay will be in clock period increments, and an internally synchronized version of the AOFEF enables or disables the generation of the TMRDACWR. The UPDATE signal simultaneously transfers the written data to the outputs of all of the DACs.

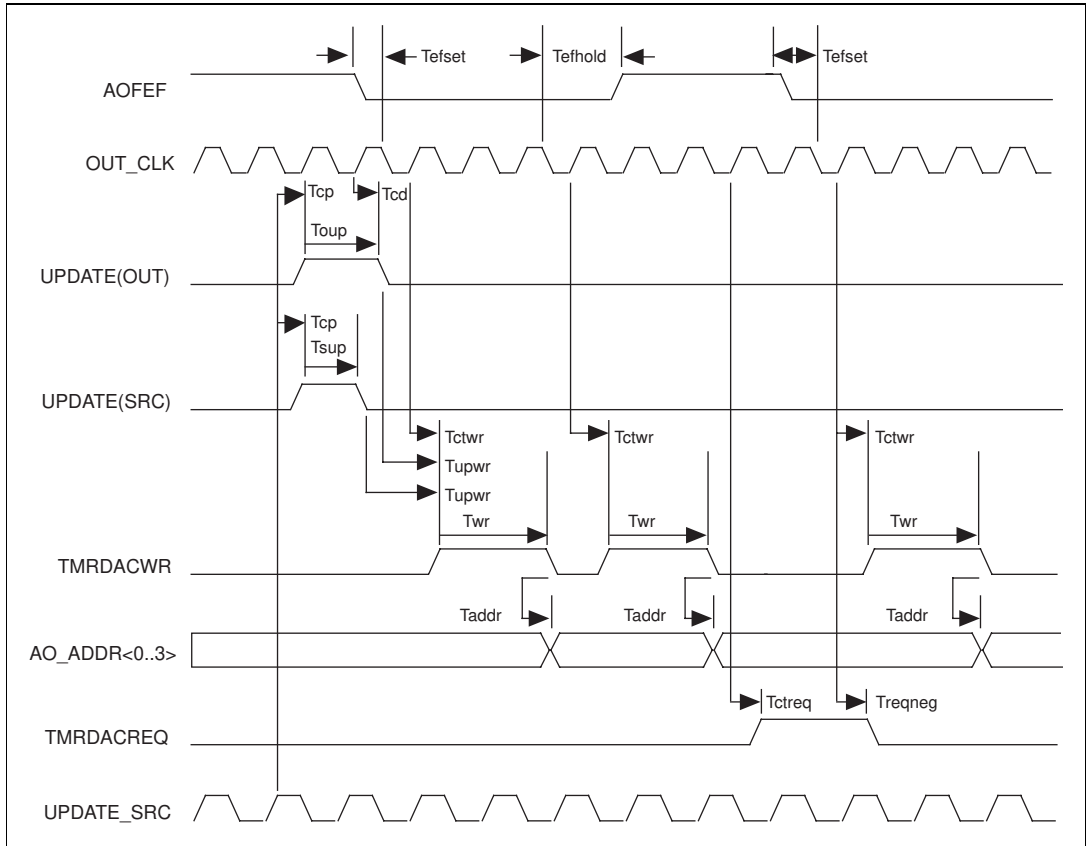

Figure 3-14. DAQ-STC-Driven Analog Output Timing

Table 3-4. DAQ-STC-Driven Analog Output Timing

Name	Description	Minimum	Maximum
Tcp	UPDATE_SRC to UPDATE asserted	18	56
Tsup	UPDATE pulsewidth (source clocks)	(1)	(1)
Toup	UPDATE pulsewidth (output clocks)	(1, 3)	(1.5, 3.5)
Tcd	OUT_CLK to UPDATE deasserted	12	28
Tupwr	UPDATE to TMRDACWR asserted	(0.5)	(1.5)
Tctwr	OUT_CLK to TMRDACWR asserted	11	34
Tctreq	OUT_CLK to TMRDACREQ asserted	10	31
Treqneg	OUT_CLK to TMRDACREQ deasserted	10	32
Twr	TMRDACWR pulsewidth	(2, 3)	(2, 3)

Table 3-4. DAQ-STC-Driven Analog Output Timing (Continued)

Name	Description	Minimum	Maximum
Taddr	TMRDACWR to AO_ADDR change	3	10
Tefset	AOFEF setup to latching edge	-15	—
Tefhold	AOFEF hold after latching edge	(0.5 clk)	—
All timing values are in nanoseconds.			

The numbers in parentheses refer to the number of clock periods that occur at the minimum and maximum delays, because those parameters are clock-edge driven with possible additional gate delays.

The UPDATE signal can be programmed to be one or three output clock periods, or one source clock period (see AO_UPDATE_Pulse_Width). The synchronization for UPDATE(OUT) counts a total of either three or seven output clock edges, regardless of polarity. The TMRDACWR signal can be set to two or three output clock periods, which is an exact number (see AO_UPDATE_Pulse_Width). There is no synchronization involved with this write signal. The AO_ADDR<0..3> will change to the appropriate values upon the trailing edge of TMRDACWR.

3.7.3 CPU-Driven Analog Output Timing

The DAQ-STC provides arbitration circuitry to prevent simultaneous access to the DAC data bus by both the CPU and the DAQ-STC, as well as timing signals for the actual write. The primary output signals are CHRDY_OUT, CPUDACWR, and AO_ADDR<0..3>, and the input signals are CPUDACREQ and the bus addresses A<1..4>.

The CPUDACREQ signal notifies the DAQ-STC that a CPU write to a DAC is being requested. CHRDY_OUT is deasserted to delay the bus cycle and operates in two software-selectable modes (see AO_Fast_CPU). In mode 0, CHRDY_OUT is asserted until the end of CPUDACWR. In mode 1, CHRDY_OUT is asserted only until the start of CPUDACWR, which maximizes bus bandwidth. In mode 1, if another request is made before the initial write is completed, CHRDY_OUT is reasserted and held until the second write is started.

The bus address lines A<1..4> are passed through to the AO_ADDR<0..3> lines during the actual CPUDACWR. This allows the board to only decode one set of address lines when both TMRDACWR and CPUDACWR are being used. Figure 3-15 shows the basic timing involved in CPU-driven analog output. Both modes of CHRDY_OUT are shown, demonstrating the savings in bus bandwidth.

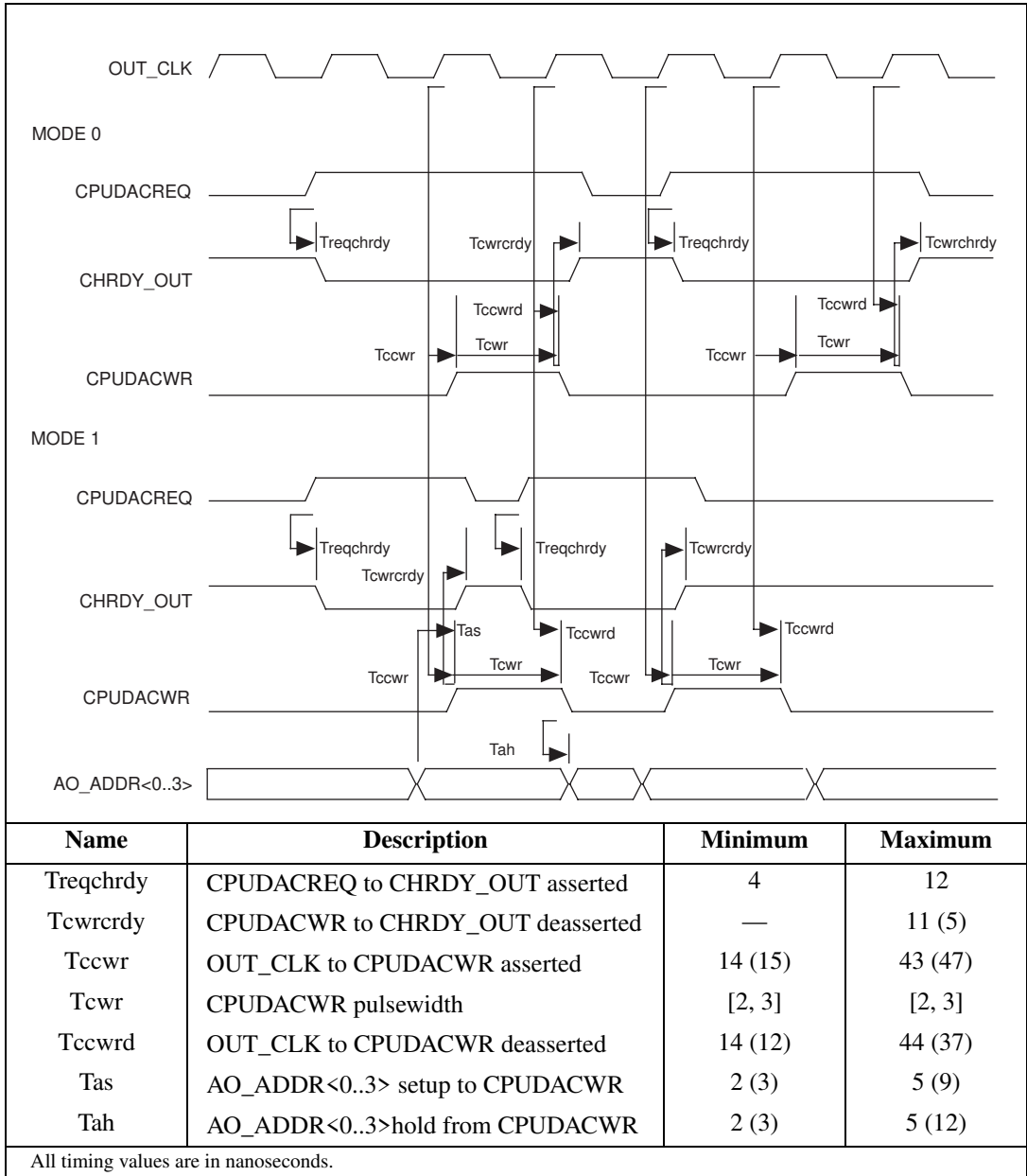

Figure 3-15. CPU-Driven Analog Output Timing

The numbers in parentheses are for DACWR<0..1>.

The numbers in square brackets indicate the number of clock periods that occur at the minimum and maximum delays, because those parameters are clock-edge driven with possible additional gate delays.

The CPUDACREQ signal is latched on the falling edge and recognized on the rising edge of the source clock. Therefore, the delay between the assertion of the CPUDACREQ signal and the assertion of the CPUDACWR signal is between 0.5 and 1.5 clock periods. The signal CPUDACWR can be programmed to two or three output clock periods, which is an exact number of periods (see AO_TMRDACWR_Pulse_Width). No synchronization is required for this signal.

3.7.4 DAQ-STC- and CPU-Driven Analog Output Timing

The possibility exists that the CPU and the DAQ-STC will both attempt to write to the DACs during overlapping time periods. The CPU is given priority over the DAQ-STC, but it cannot interrupt a DAQ-STC write cycle in progress. If the DAQ-STC is writing to the DACs, the CPU bus cycle will be extended to the next write slot. This case is detailed in Figure 3-16.

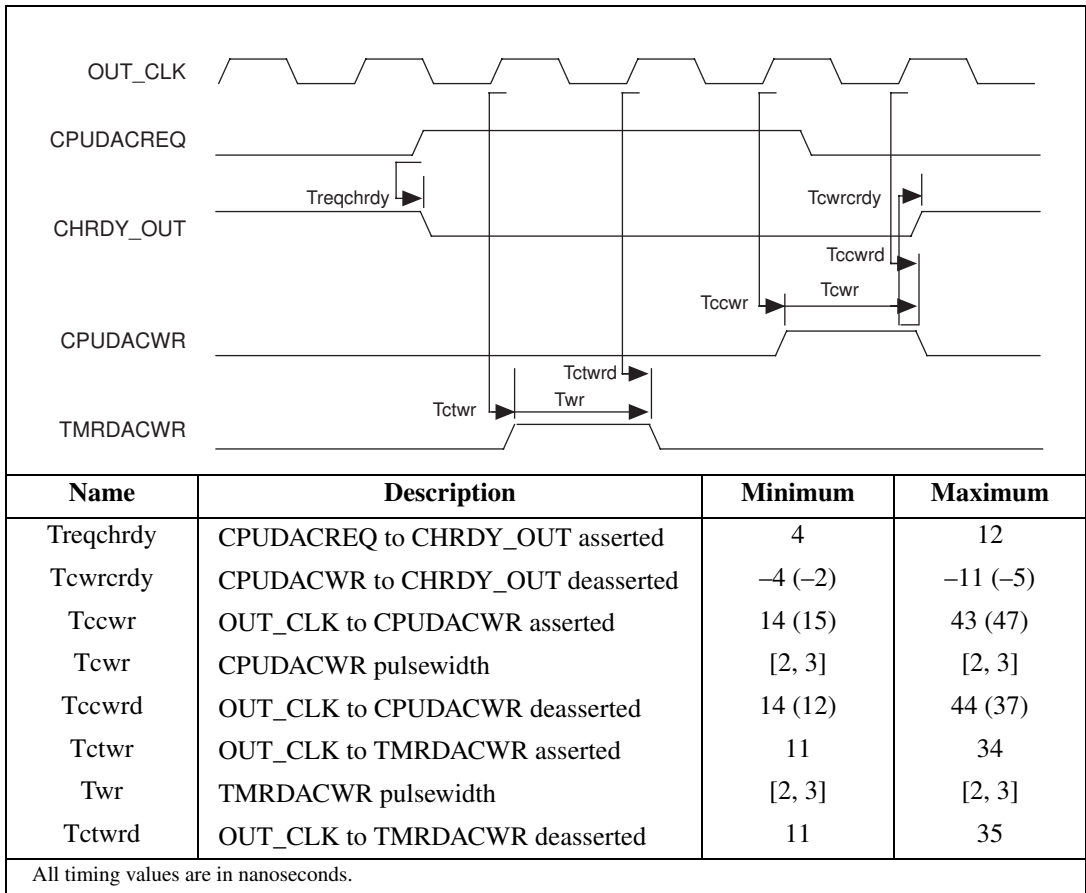

Figure 3-16. Analog Output Contention Timing, Case A

The numbers in parentheses are for DACWR<0..1>.

The numbers in square brackets indicate the number of clock periods that occur at the minimum and maximum delays, because those parameters are clock-edge driven with possible additional gate delays.

The CPUDACREQ signal is recognized on the falling edge of the output clock. If TMRDACWR is already asserted, the bus cycle is delayed to the next write slot. In this case the CPUDACREQ signal was asserted immediately after the falling edge of the output clock, so the DAQ-STC continued with its own write cycle. Each write slot is separated by one clock period, as shown in the timing diagram. The two signals CPUDACWR and TMRDACWR can never occur at the same time and will be separated by at least one clock period.

The second case occurs when the CPUDACREQ signal is recognized on a falling edge of the output clock before TMRDACWR is asserted. In this case the CPU-driven write will occur immediately, while the DAQ-STC-driven write will be delayed, as shown in Figure 3-17. The shaded region of the signal TMRDACWR indicates where the TMRDACWR signal would have been asserted had there been no contention. Notice that the two write pulses are again separated by one clock period. The timing parameters are identical to those for the first conflict case.

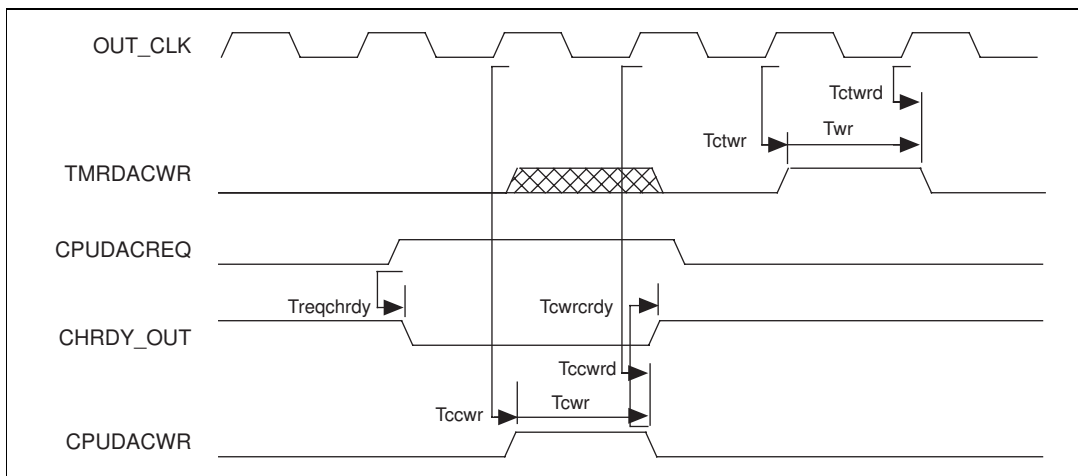

Figure 3-17. Analog Output Contention Timing, Case B

3.7.5 Secondary Analog Output Timing

The DAQ-STC supports a limited secondary group for analog output. An on-chip 16-bit counter/timer is connected to the UPDATE2 pin, which can provide periodic update pulses. This counter/timer can also generate an interrupt to coincide with each update pulse, which can be used for a straightforward interrupt-driven analog output. With appropriate external circuitry, DMA operations could be performed as well. Figure 3-18 shows the timing for this signal.

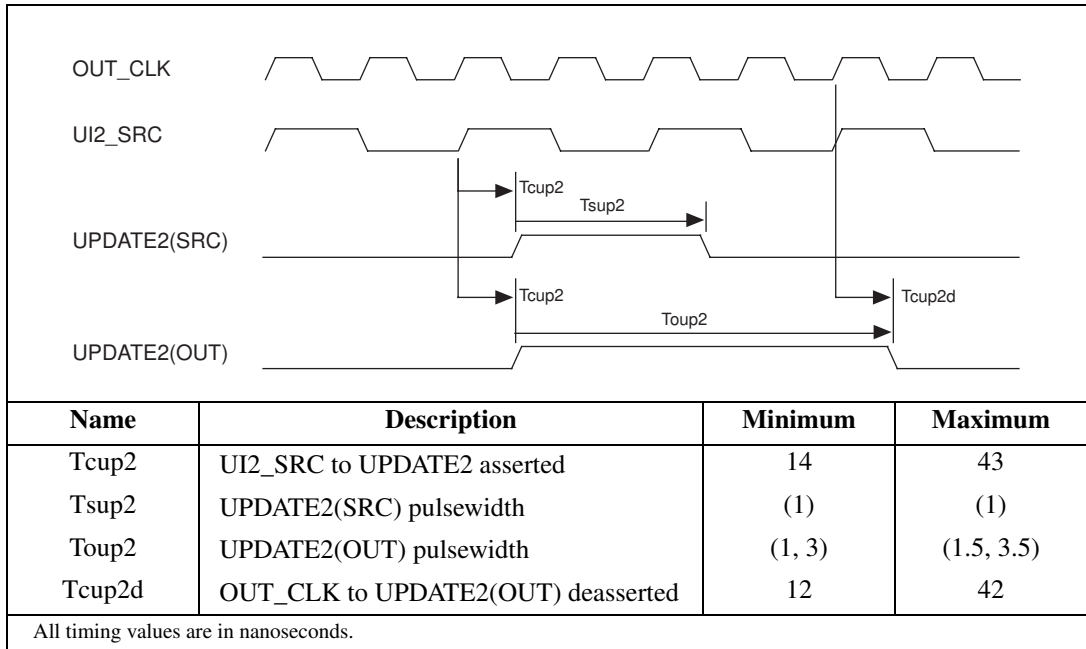

Figure 3-18. Secondary Analog Output Timing

The numbers in parentheses indicate the number of clock periods that occur at the minimum and maximum delays, because those parameters are clock edge driven with possible additional gate delays.

The UPDATE2 signal can be programmed to one or three output clock periods, or one source clock period (see AO_UPDATE2_Pulse_Width). The synchronization for UPDATE2(OUT) counts either three or seven output clock edges, regardless of polarity.

3.7.6 Decoded Signal Timing

The DAQ-STC provides direct support for two DAC groups. The output signals LDAC0 and LDAC1 can be directly connected to the DACs. These signals can be individually configured for timed or immediate update modes (see AO_DAC_i Update_Mode). In the immediate update mode, LDAC_i is driven inactive only during either a TMRDACWR or CPUDACWR. This allows the DACs to immediately update to their new values. In the timed update mode, LDAC_i is a multiplexer which selects between UPDATE and UPDATE2. This allows the DAC group to be driven by either the primary or secondary analog output circuitry.

The output signals DACWR0 and DACWR1 are decoded versions of TMRDACWR and CPUDACWR based on the AO_ADDR0 line. The appropriate DACWR_i is driven active during either a TMRDACWR or CPUDACWR cycle. The DACWR0 signal can be configured to ignore the AO_ADDR0 line, for use with a single DAC package. In this option, the DACWR0 signal will be asserted on every TMRDACWR and CPUDACWR cycle.

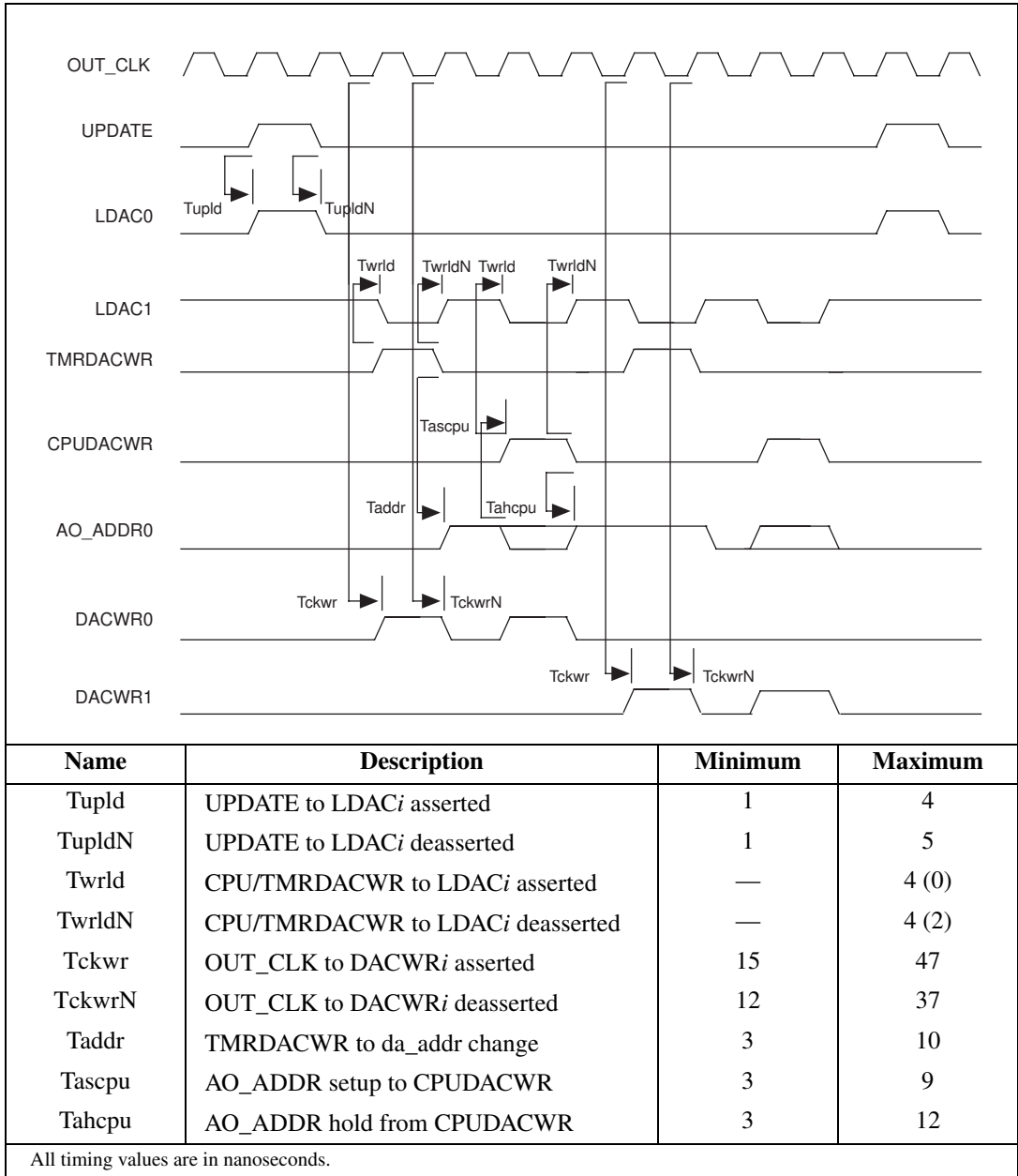

Figure 3-19. Decoded Signal Timing

The numbers in parentheses are for DACWR<0..1>.

3.7.7 Local Buffer Mode Timing

The DAQ-STC supports a local buffer mode for analog output, which reduces analog output bus usage to zero. The desired waveform is written into the data FIFO, and the buffer is repeated a number of times. The primary signals are UPDATE, TMRDACWR, AO_ADDR<0..3>, AOFFRT, and AOFEF. The UPDATE, TMRDACWR, and AO_ADDR<0..3> signals operate identically to the basic analog output case. The AOFEF signal is the data FIFO empty flag, and the AOFFRT signal asserts the retransmit signal on the FIFO. When the FIFO becomes empty, the DAQ-STC asserts the AOFFRT signal, which sets the FIFO read pointer back to the first location of the FIFO. The waveform can then be output again, as shown in Figure 3-20.

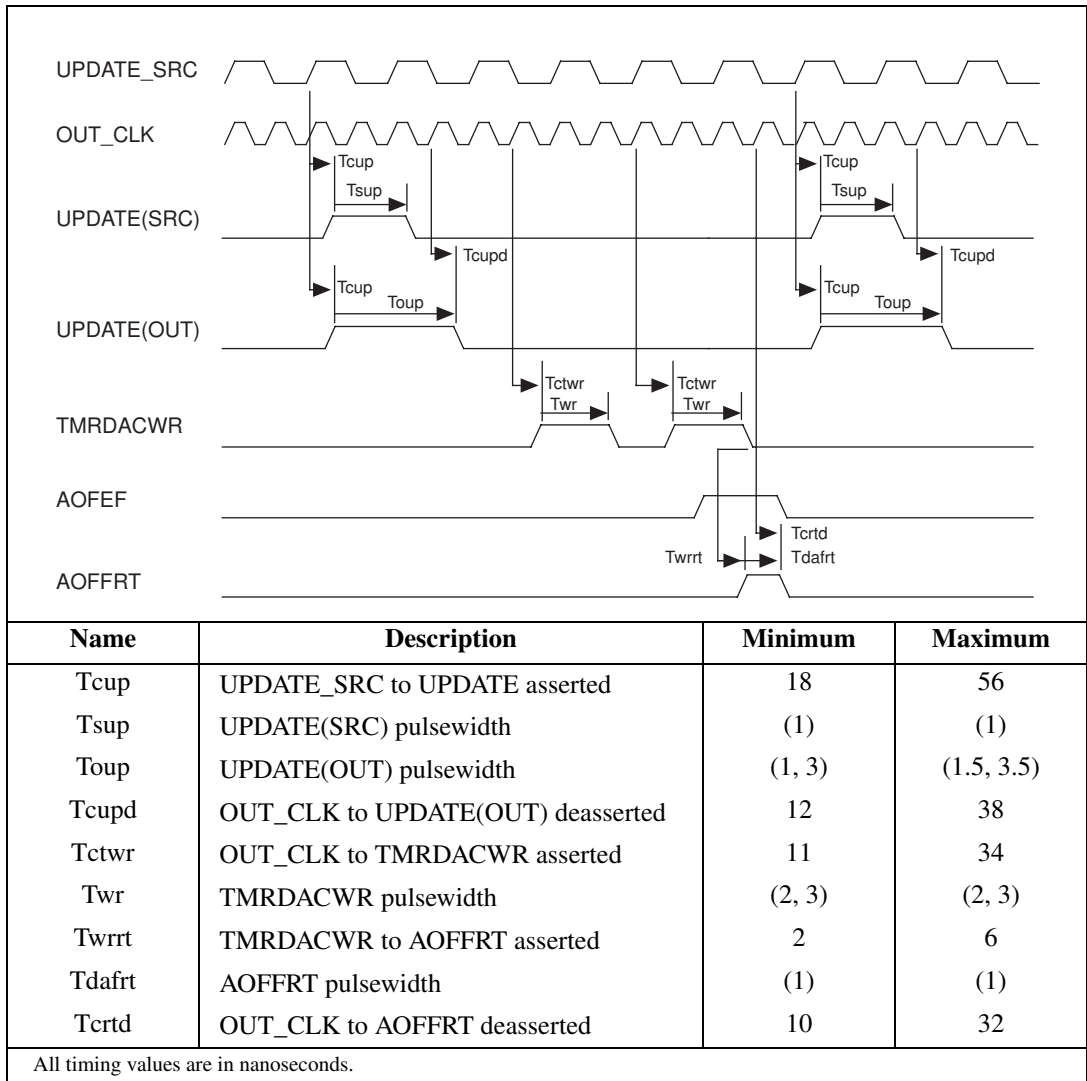

Figure 3-20. Local Buffer Mode Timing

The numbers in parentheses refer to the number of clock periods that occur at the minimum and maximum delays, because those parameters are clock-edge driven with possible additional gate delays.

The AOFFRT is recognized by the DAQ-STC at the trailing edge of the TMRDACWR signal. This leads to the assertion of AOFFRT, which is deasserted on the next rising edge of the output clock.

3.7.8 Unbuffered Data Interface Timing

The DAQ-STC provides support for low-cost DAQ boards that do not contain analog output data FIFOs. A basic application could simply use the CPU-driven examples given above, but this wastes the host CPU resources. The DAQ-STC provides a DMA mode of operation where the FIFOs can be omitted. Due to the pinout restriction on the DAQ-STC, several of the pins provide dual functionality and their operation differs here. The primary output signals are UPDATE, TMRDACWR, CHRDY_OUT, CPUDACWR, and AO_ADDR<0..3>. Primary input signals are AOFEF and CPUDACREQ. Figure 3-21 shows the timing for this mode.

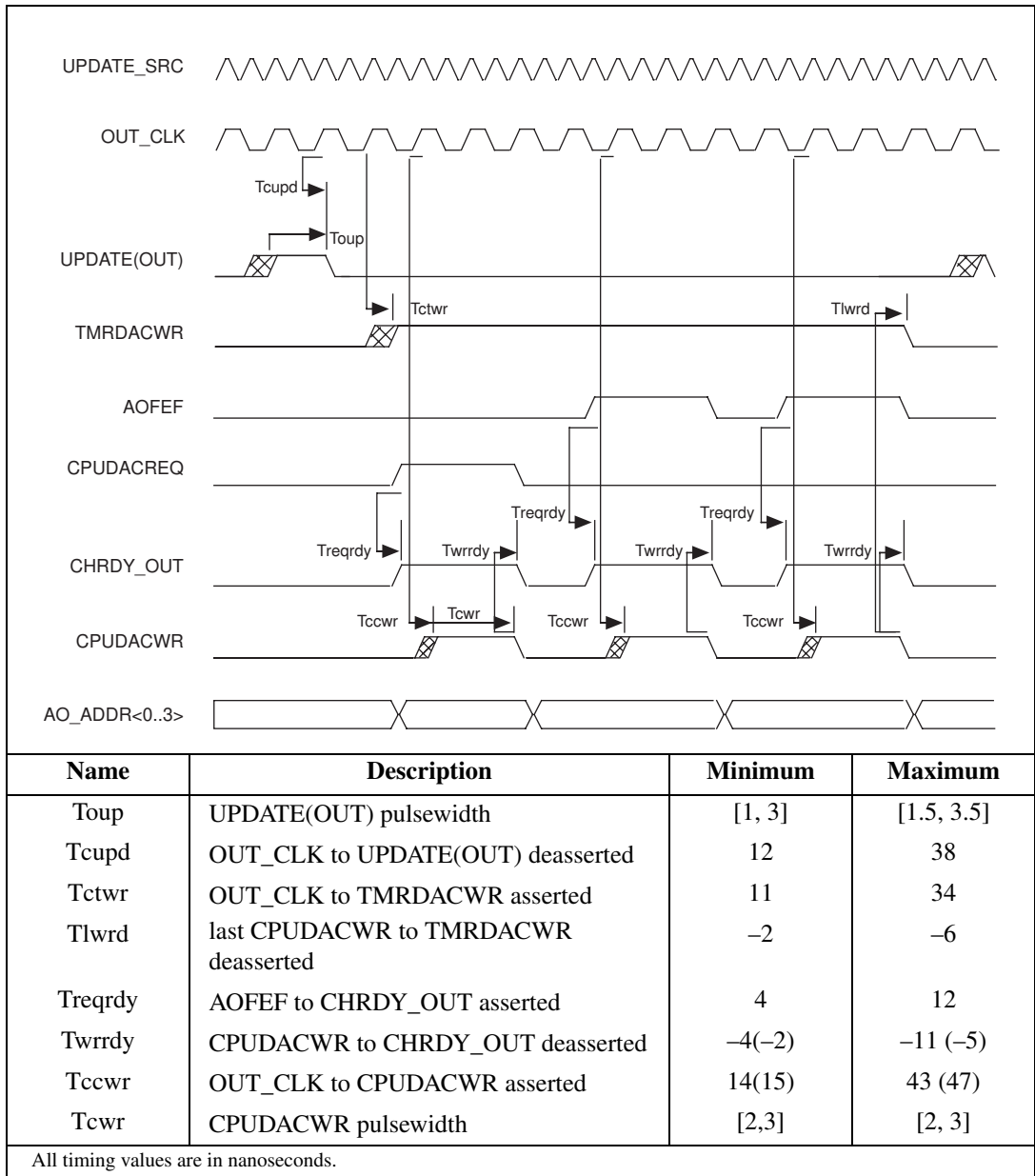

Figure 3-21. Unbuffered Data Interface Timing

The numbers in parentheses are for DACWR<0..1>.

The numbers in square brackets indicate the number of clock periods that occur at the minimum and maximum delays, because those parameters are clock-edge driven with possible additional gate delays.

The UPDATE signal still performs the updating of the DACs, as before. The TMRDACWR signal is now used as a DMA request, indicating that new data is needed for the analog output. The CPUDACWR signal is used to actually write the DMA data to the DACs. The TMRDACWR signal will remain asserted until the completion of the last CPUDACWR. The AOFFF input is the DMA acknowledge, indicating that the DMA data is ready for the write.

The CPUDACREQ input is still used to provide CPU access to DACs. The CHRDY_OUT signal acts as before, and extends the bus cycle to the appropriate length during both of CPU or DMA accesses. The AO_ADDR<0..3> lines still indicate the destination DAC but change on the CPUDACWR signal instead of the TMRDACWR signal as before. The bus address lines A<0..3> will still pass through to the AO_ADDR<0..3> lines during a CPU access.

3.7.9 Maximum Update Rate Timing

The maximum analog output rates that the DAQ-STC obtains depend upon the number of channels selected for output. Every output sequence consists of an UPDATE pulse followed by the appropriate number of TMRDACWR or CPUDACWR pulses. Only one UPDATE pulse is required for all DACs; therefore, the total throughput increases as the number of channels used increases. This is shown in Figure 3-22, where three channels are being written.

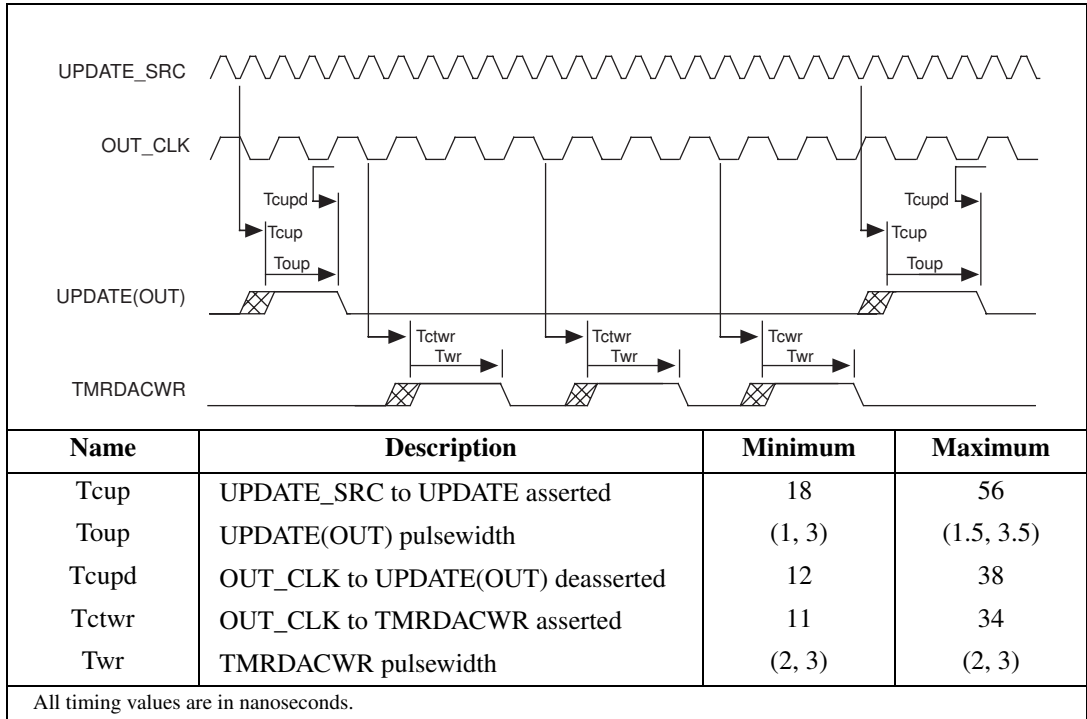

Figure 3-22. Maximum Update Rate Timing

The numbers in parentheses indicate the number of clock periods that occur at the minimum and maximum delays, because those parameters are clock-edge driven with possible additional gate delays.

The highest throughput for analog output occurs when back-to-back updates are programmed via the counter/timer. In the above example, the shortest pulsewidths for each signal have been selected. The UPDATE pulse is one output clock period long, while each TMRDACWR signal is two output clock periods long. The first TMRDACWR pulse occurs one output clock period after the UPDATE pulse, and there is one output clock period between each successive TMRDACWR. The next UPDATE pulse can be asserted at the same output clock edge on which the last TMRDACWR signal is deasserted. Therefore, the shortest cycle time for the case above is four output clock periods for one channel, plus three output clock periods for

each additional active channel. This example uses three channels, so the period for the entire cycle is 10 output clock periods. With a 10 MHz source and output clock, this corresponds to 1 μ s, or a per channel rate of 1 MHz.

3.7.10 External Trigger Timing

The external control of the analog output is very similar to the AITM but with fewer signals to control. The primary analog output module consists of the UI, UC, and BC counters. This circuitry provides extensive hardware support for waveform generation and is intended as the main source of analog output control on the DAQ-STC. The signals to be controlled externally are START1 and UPDATE. The PFI<0..9> and RTSI_TRIGGER<0..6> signals are used for the external interface, along with software strobes. The secondary analog output module consists of the single-counter UI2. This 16-bit counter begins counting immediately after it is armed by software. Software can also strobe the UPDATE2 pin for non-timed applications.

These signals are latched and recognized for use by the analog output control circuit in the same fashion as the external signals in the analog input module. They can also be either edge sensitive or level sensitive. When an external UPDATE source is being used, the state clock will be generated by a combination of the UPDATE_SRC and a delayed version of UPDATE_SRC.

The four modes of behavior for the START1 signal and UPDATE_SRC are shown in Figures 3-23 through 3-28. The four modes are called asynchronous-level sensitive, asynchronous edge sensitive, synchronous-level sensitive, and synchronous edge sensitive.

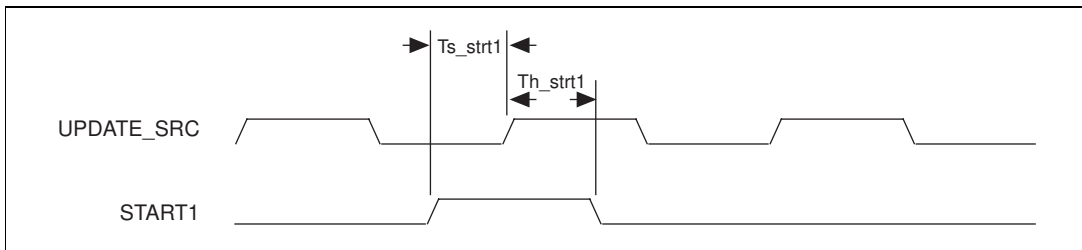

Figure 3-23. External Trigger, Asynchronous Level

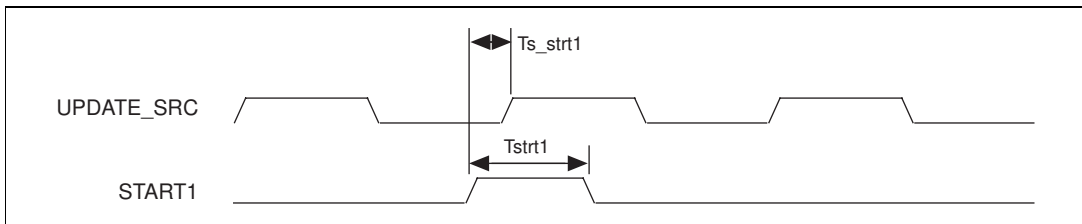

Figure 3-24. External Trigger, Asynchronous Edge

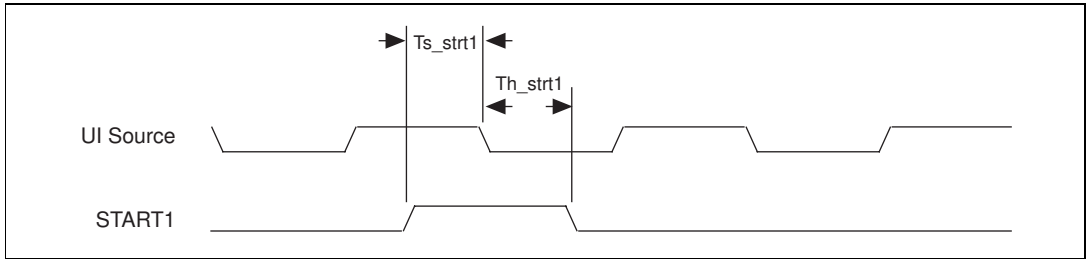

Figure 3-25. External Trigger, Synchronous Level, Internal UPDATE Mode

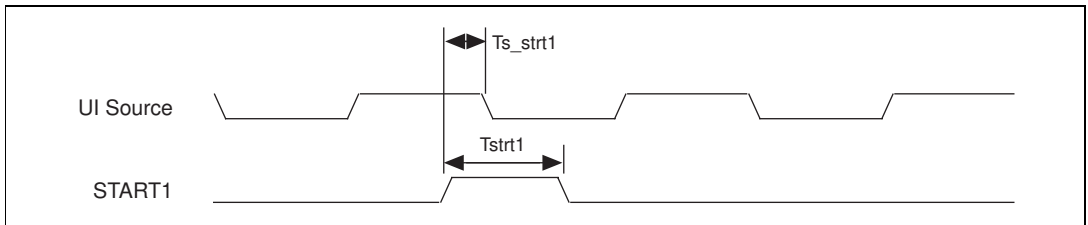

Figure 3-26. External Trigger, Synchronous Edge, Internal UPDATE Mode

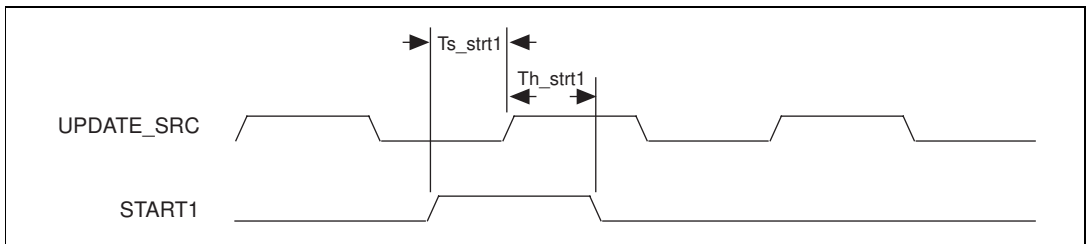

Figure 3-27. External Trigger, Synchronous Level, External UPDATE Mode

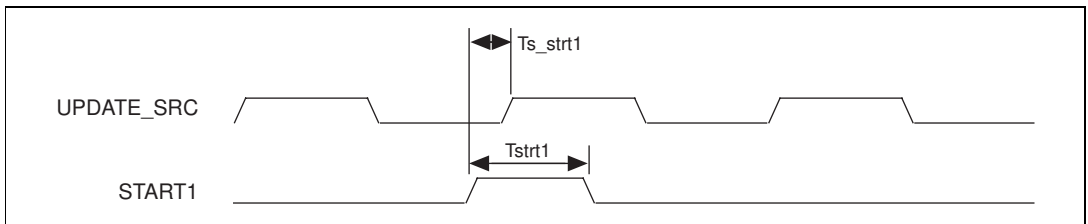

Figure 3-28. External Trigger, Synchronous Edge, External UPDATE Mode

Table 3-5. External Trigger Timing

Name	Description	Minimum	Maximum
Ts_strt1	START1 setup to UPDATE_SRC	10	—
Tstrt1	START1 pulsewidth (edge mode)	6	—
Th_strt1	START1 hold from UPDATE_SRC (level mode)	10	—
All timing values are in nanoseconds.			

3.7.11 Trigger Output

You can output the internal triggers to the board through the PFI or RTSI interface. This section lists the propagation delays for the triggers when you configure them for output to the board.

3.7.11.1 START1 Trigger

You can output the START1 trigger on the PFI output PFI6/AO_START1 or on any RTSI output. Timing for the START1 trigger depends on whether you select synchronous mode or asynchronous mode, using AO_START1_Sync.

Synchronous Mode

When you select synchronous mode for START1, the timing depends on whether you select internal UPDATE or external UPDATE, using AI_UPDATE_Source_Select. In the internal UPDATE mode, the inactive edge of the UI source that recognizes the external trigger generates the output. Figure 3-29 shows the propagation delays for START1.

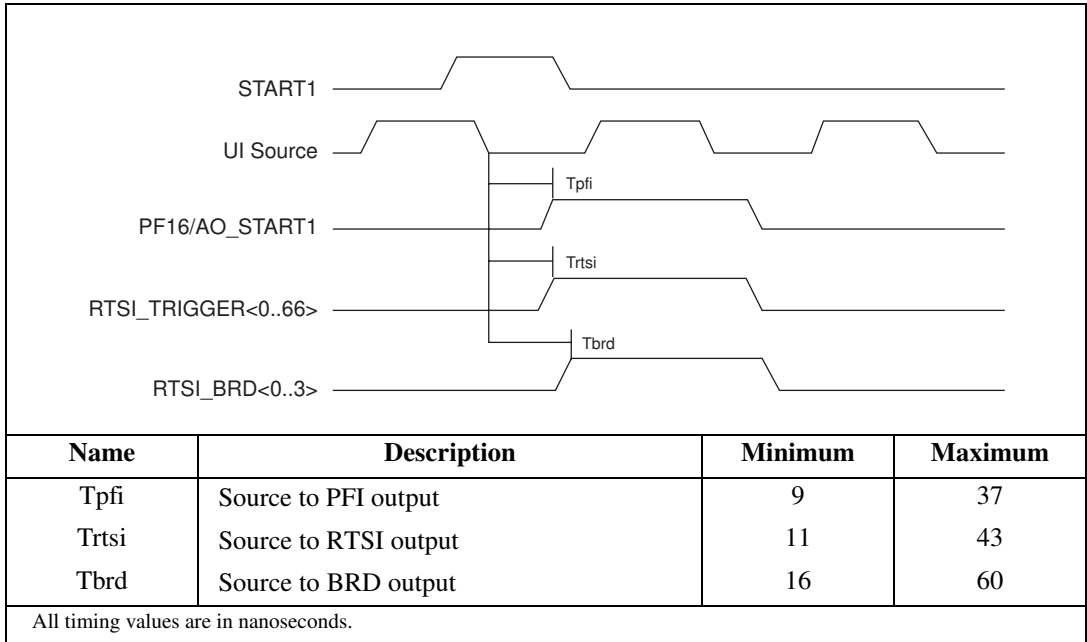

Figure 3-29. START1 Delays, Synchronous Mode, Internal UPDATE

In the external UPDATE mode, the active edge of UPDATE_SRC that recognizes the external trigger generates the output. Figure 3-30 shows the propagation delays for START1.

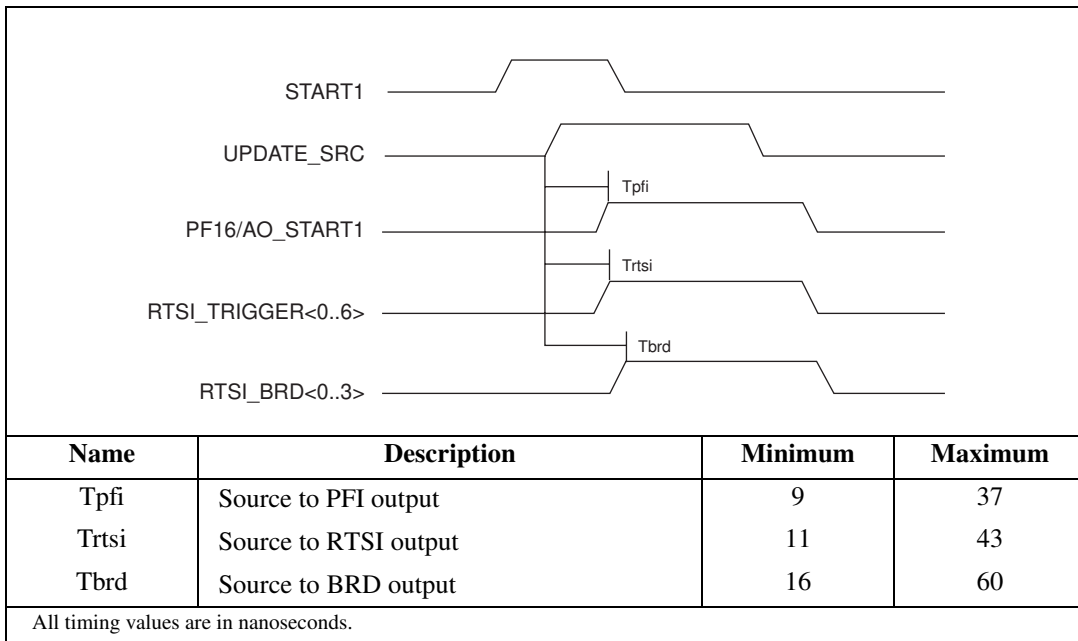

Figure 3-30. START1 Delays, Synchronous Mode, External UPDATE

Asynchronous Mode

When you select asynchronous mode for START1, the external trigger itself generates the rising edge of the output. Figure 3-31 shows the propagation delays for START1.

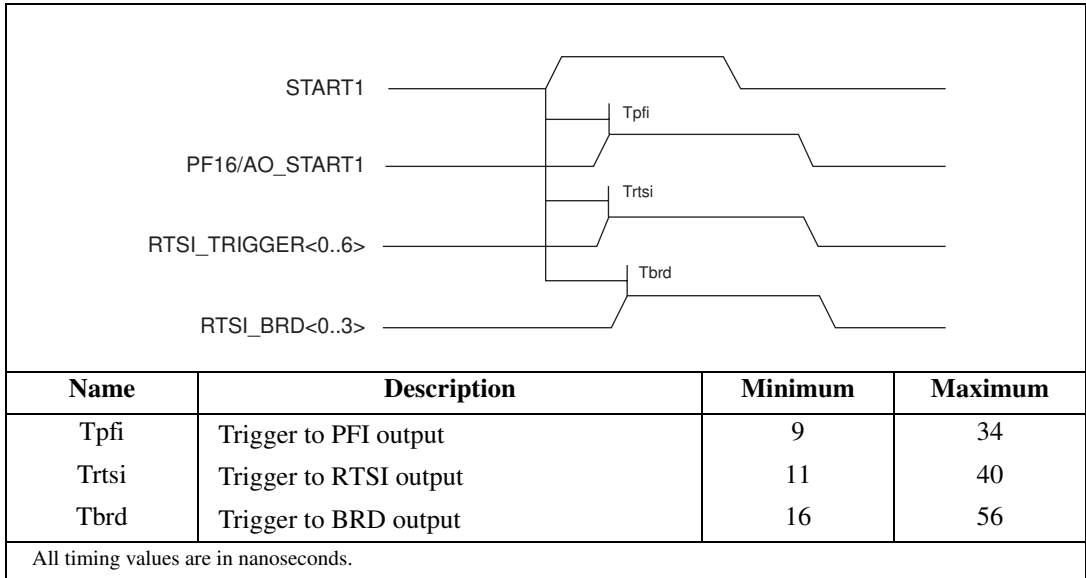

Figure 3-31. START1 Delays, Asynchronous Mode

3.7.12 Counter Outputs

You can also output the internal counter TC signals to the board. This section presents the output timing for the BC_TC and UC_TC outputs.

3.7.12.1 BC_TC

Figure 3-32 shows the delays associated with the BC_TC signal.

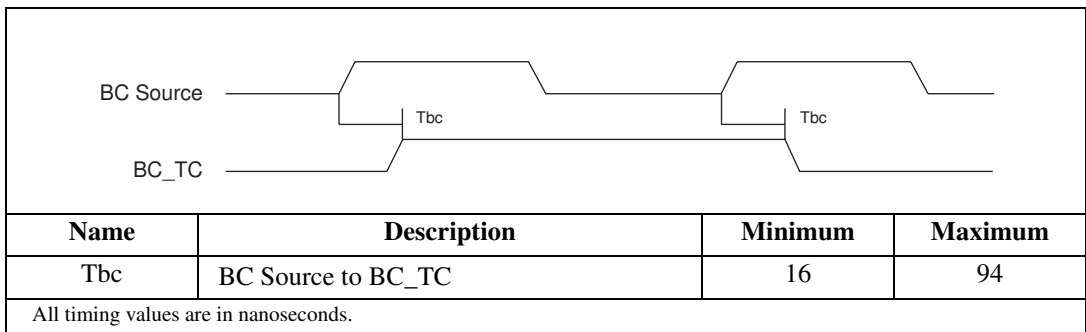

Figure 3-32. BC_TC Delay

3.7.12.2 UC_TC

Figure 3-33 shows the delays associated with the UC_TC signal.

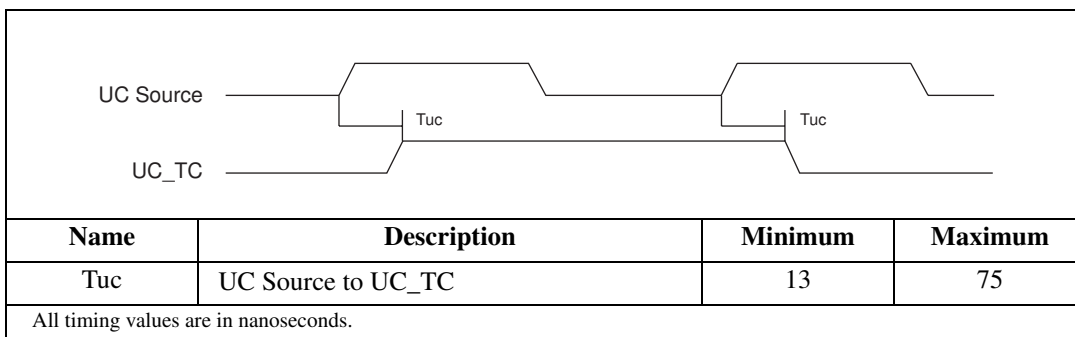

Figure 3-33. UC_TC Delay

3.8 Detailed Description

This section describes the AOTM module in detail. You need not read this section unless you need to understand the inner workings of the circuit. This section refers to bitfields in the AOTM related registers in the DAQ-STC register map. See Appendix B, [Register Information](#), for more information on the register addresses containing these bitfields.

Figure 3-34 shows a block diagram of the AOTM. The AOTM contains four special purpose counters—the BC, UI, UI2, and UC counters. Each counter has dual-load registers (A and B) to handle two parameters for each timing layer. In addition to the counters, the primary logic blocks are the counter control blocks, the trigger block, the interrupt control block, and the output control block.

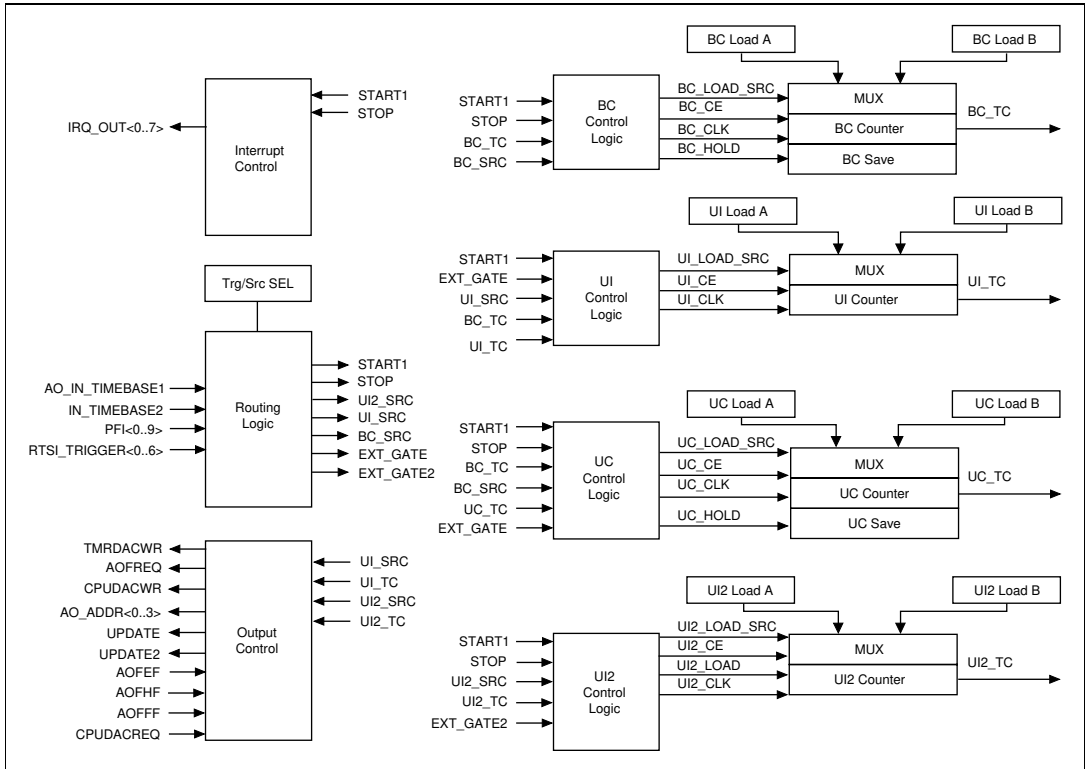

Figure 3-34. AOTM Block Diagram

3.8.1 Internal Signals and Operation

Table 3-6 contains brief descriptions of the internal signals shown in the block diagram or discussed in section 3.8, *Detailed Description*.

Table 3-6. Internal Signals

Signal	Description
AO_END1	End on UC_TC—This signal is the schematic name for the synchronized version of the register map bitfield AO_End_On_UC_TC.
AO_END2	End on BC_TC—This signal is the schematic name for the synchronized version of the register map bitfield AO_End_On_BC_TC.

Table 3-6. Internal Signals (Continued)

Signal	Description
AO_IN_TIMEBASE1	Internal Timebase for the Analog Output Module—AO_IN_TIMEBASE1 can be selected to be the same as OSC, or it can be OSC divided by two. Related bitfields: AO_Source_Divide_By_2.
AO_OUT_TIMEBASE	AO Output Clock—This signal times the output circuitry for analog output. Related bitfields: AO_OUTPUT_Divide_By_2.
BC_CE	BC Count Enable—This signal enables and disables the BC counter. Refer to Figure 3-39 for the BC_CE logic equations.
BC_CLK	BC Clock—The BC clock signal is the actual clock for the BC counter and the BC control logic. When the counter is not armed, BC_CLK is the write strobe for AO_Command_1_Register so that the counter can be loaded using the load command. When the counter is armed, BC_CLK is the same as BC_SRC.
BC_DISARM	BC Disarm—This signal, which is generated by the BC control circuit, disarms the BC counter by asynchronously clearing AO_BC_Arm.
BC_HOLD	BC Hold—This signal controls the BC save register. If BC_HOLD = 0, the BC save register tracks the BC counter output. If BC_HOLD = 1, the BC save register latches the BC counter output. Related bitfields: AO_BC_Save_Trace.
BC_LOAD	BC Load—This signal pulses to load the value from the selected BC load register into the BC counter. Related bitfields: AO_BC_Load.
BC_LOAD_SRC	BC Load Source—This signal determines which load register, A or B, the BC counter will use on the next reload. The initial BC load source is set using AO_BC_Initial_Load_Source. The BC control logic updates BC_LOAD_SRC while the DAQ-STC is counting. The current load source depends on the counter state and the selected reload mode. Related bitfields: AO_BC_Initial_Load_Source, AO_BC_Next_Load_Source_St, AO_BC_Reload_Mode.
BC_SRC	BC Source—The BC source is the timebase for the buffer (BC) counter and update (UC) counter. If an internally generated UPDATE is used, the BC source is the same signal as the UI_SRC. If an externally generated UPDATE is used, the UPDATE clock itself serves as the BC source. The external trigger and gate inputs which are not generated synchronous to the BC source outside of the timer can and should be synchronized to the BC source inside of the timer.

Table 3-6. Internal Signals (Continued)

Signal	Description
BC_TC	Buffer Repetition Counter TC—This signal indicates the completion of an MISB.
DACUPDN	DAC Update —This signal appears on the UPDATE pin. The hardware generates DACUPDN by passing the SCLK signal through pulsewidth and polarity selection circuitry. If the UPDATE pin is configured for high impedance, this signal will be GND. Related bitfields: AI_UPDATE_Output_Select, AI_UPDATE_Original_Pulse, AI_UPDATE_Pulse_Timebase, AI_UPDATE_Pulse_Width.
DA_ST1ED	Output Version of START1—The hardware generates DA_ST1ED by passing the output of the START1 selector through polarity selection and edge detection, but not synchronization.
DA_START1	START1 without Master/Slave Sync—The hardware generates DA_START1 by passing the output of the START1 selector through polarity selection, edge detection, and synchronization, bypassing the master/slave synchronization.
EXT_GATE	External Gate—The external gate can be used to gate the UPDATE output. It is selectable from either polarity of PFI<0..9> or from RTSI_TRIGGER<0..6>. Related bitfields: AO_External_Gate_Enable, AO_External_Gate_Select, AO_External_Gate_Polarity, AO_External_Gate_St.
EXT_GATE2	Secondary External Gate—This signal can be used to gate the UPDATE2 output. It is selectable from either polarity of PFI<0..9> or from RTSI_TRIGGER<0..6>. Related bitfields: AO_UI2_External_Gate_Enable, AO_UI2_External_Gate_Select, AO_UI2_External_Gate_Polarity, AO_UI2_Gate_St.
FSCLK	Fast Update Clock—This signal is the output of the UPDATE selector, after polarity selection. Related bitfields: AI_UPDATE_Source_Select, AI_UPDATE_Polarity_Select.
IN_TIMEBASE2	Slow Internal Timebase—This timebase is derived from the OSC input and is usually configured to be 100 kHz. Related bitfields: Slow_Internal_Time_Divide_By_2, Slow_Internal_Timebase.
INT_SCLK_SEL	Internal Update Indicator—This signal indicates whether internal or external UPDATE mode is selected. It is 1 for internal UPDATE mode and 0 for external UPDATE mode.

Table 3-6. Internal Signals (Continued)

Signal	Description
SCKG	Internal UPDATE—This signal is 1 in the external UPDATE mode and is equal to UI_TC in the internal UPDATE mode.
SCLK	Internal Update Clock—In the internal UPDATE mode, SCLK is the signal UI_TC. In the external UPDATE mode, SCLK is the signal FSCLK after it passes through a delay gate. The delay gate is provided so that signals synchronized to FSCLK have sufficient time to settle to a known state before being used by SCLK.
START1	Start Trigger for the UI, UC, and BC Counters—The start trigger is software selectable from the either polarity of the PFI<0..9>, RTSI_TRIGGER<0..6>, software strobe, or AI_START1. It can be programmed to be edge or level sensitive and can be synchronized to the BC_SRC. Related bitfields: AO_START1_Source_Select, AO_START1_Edge, AO_START1_Sync, AO_START1_Polarity.
STOP	Stop—This signal terminates the buffer in progress. It is the same signal as UC_TC.
UC_CE	UC Count Enable—This signal enables and disables the UC counter. Refer to Figure 3-38 for the UC_CE logic equations.
UC_CLK	UC Clock—The UC clock signal is the actual clock signal for the UC counter and the UC counter control logic. When the counter is not armed, UC_CLK is the write strobe for AO_Command_1_Register, so that the counter can be loaded using the load command. When the counter is armed, UC_CLK is the same as BC_SRC.
UC_DISARM	UC Disarm—This signal, which is generated by the UC control circuit, disarms the UC counter by asynchronously clearing AO_UC_Arm.
UC_HOLD	UC Hold—This signal controls the UC save register. If UC_HOLD = 0, the UC save register tracks the UC counter output. If UC_HOLD = 1, the UC save register latches the UC counter output. Related bitfields: AO_UC_Save_Trace.
UC_LOAD	UC Load—This signal pulses to load the value from the selected UC load register into the UC counter. Related bitfields: AO_UC_Load.

Table 3-6. Internal Signals (Continued)

Signal	Description
UC_LOAD_SRC	UC Load Source—This signal determines which load register, A or B, the UC counter will use on the next reload. The initial UC load source is set using AO_UC_Initial_Load_Source. The UC control logic updates the UC_LOAD_SRC while the DAQ-STC is counting. Related bitfields: AO_UC_Initial_Load_Source, AO_UC_Next_Load_Source_St.
UC_TC	Update Counter TC—This signal indicates to the counter control logic that the programmed number of updates has been generated (end of a buffer).
UI_CE	UI Count Enable—This signal enables and disables the UI counter. It is true when the UI counter is active (UI control state CNT), and false when the UI counter is idle (UI control state WAIT).
UI_CLK	UI Clock—The UI clock signal is the actual clock for the UI counter and the UI control logic. When the counter is not armed, UI_CLK is derived from the write strobe for AO_Command_1_Register, so that the counter can be loaded using the load command. When the counter is armed, UI_CLK is the same as UI_SRC.
UI_DISARM	UI Disarm—This signal, which is generated by the UI control circuit, disarms the UI counter by asynchronously clearing AO_UI_Arm.
UI_LOAD	UI Load—This signal pulses to load the value from the selected UI load register into the UI counter. Related Bitfields: AO_UI_Load.
UI_LOAD_SRC	UI Load Source—This signal determines which load register, A or B, the UI counter will use on the next reload. The initial UI load source is set using AO_UI_Initial_Load_Source. The UI control logic updates UI_LOAD_SRC while the DAQ-STC is counting. The current load source depends on the counter state and the selected reload mode. Related bitfields: AO_UI_Initial_Load_Source, AO_UI_Next_Load_Source_St, AO_UI_Reload_Mode.
UI_SRC	UI Source—The UI source is the timebase for the UI counter. It is software selectable from AO_IN_TIMEBASE1, IN_TIMEBASE2, PFI<0..9>, and RTSI_TRIGGER<0..6>. Related bitfields: AO_UI_Source_Select.
UI_TC	Update Interval Counter TC—The UI_TC signal is primarily used as the internal UPDATE.

Table 3-6. Internal Signals (Continued)

Signal	Description
UI2_CE	UI2 Count Enable—This signal enables and disables the UI2 counter. Refer to section 3.8.3.8, <i>UI2 Control</i> , for the UI2_CE equations.
UI2_CLK	UI2 Clock—The UI2 clock signal is the actual clock for the UI2 counter and the UI2 control logic. When the counter is not armed, UI2_CLK is the write strobe for AO_Command_1_Register, so that the counter can be loaded using the load command. When the counter is armed, UI2_CLK is the same as UI2_SRC.
UI2_LOAD	UI2 Load—This signal pulses to load the value from the selected UI2 load register into the UI2 counter. Related bitfields: AO_UI2_Load.
UI2_LOAD_SRC	UI2 Load Source—This signal determines which load register, A or B, the UI2 counter will use on the next reload. The initial UI2 load source is set using AO_UI2_Initial_Load_Source. The UI2 control logic updates UI2_LOAD_SRC while the DAQ-STC is counting. The current load source depends on the counter state and the selected reload mode. Related bitfields: AO_UI2_Initial_Load_Source, AO_UI2_Next_Load_Source_St, AO_UI2_Reload_Mode.
UI2_SRC	UI2 Source—The UI2 source is the timebase for the UI2 counter. It is software selectable from AO_IN_TIMEBASE1, IN_TIMEBASE2, the G_TC signal from general-purpose counter 0 or 1, PFI<0..9>, and RTSI_TRIGGER<0..6>. Related bitfields: AO_UI2_Source_Select.
UI2_TC	Secondary Update Interval TC—The UI2_TC signal is the independent secondary update interval clock.

3.8.2 Trigger Selection and Conditioning

The signal routing block selects the counter clocks, trigger signals, and gate signals from the default timebases. The routing logic for the UI_SRC, UI2_SRC, and BC_SRC signals is a 20-to-1 multiplexer followed by an exclusive OR gate for polarity selection. The routing logic for the trigger signal START1 has additional controls for edge detection and synchronization, as shown in Figure 3-35. When synchronization is selected, START1 is synchronized to both UI_SRC and BC_SRC.

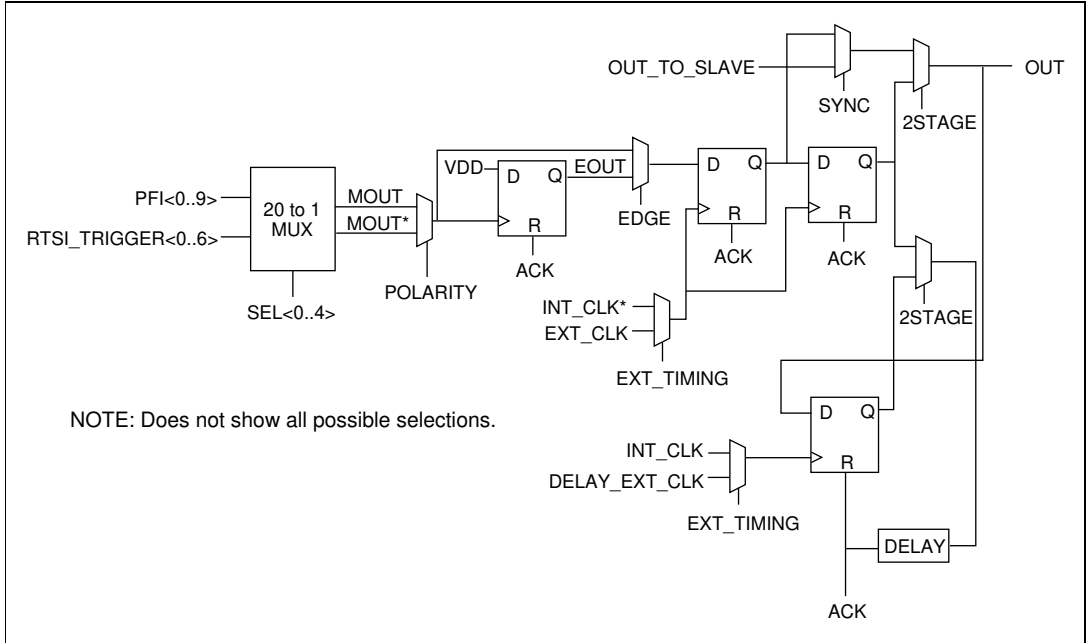

Figure 3-35. START1 Routing Logic

Figure 3-36 depicts the control for EXT_GATE and EXT_GATE2.

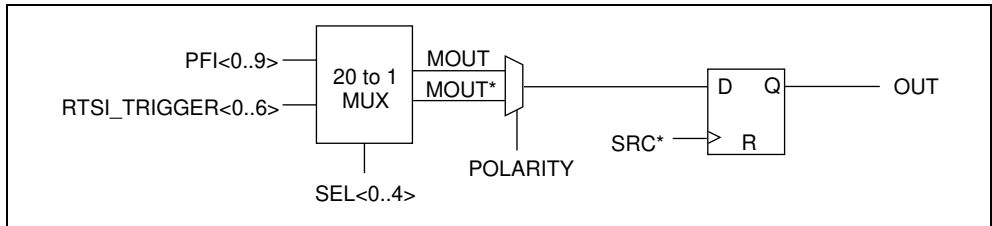

Figure 3-36. EXT_GATE and EXT_GATE2 Routing Logic

Table 3-7 summarizes the selections available for each of the trigger signals through the PFI selector.

Table 3-7. PFI Selectors

MUX	0	1-10	11-17	18	19	20	31
AO_START1_Source	SW	PFI<0..9>	RTSI<0..6>	—	AI_ST1	—	GND
AO_START_Source	SW, UC_TC	PFI<0..9>	RTSI<0..6>	—	—	—	GND
AO_UPDATE_Source	UI_TC	PFI<0..9>	RTSI<0..6>	—	GOUT1	—	GND

Table 3-7. PFI Selectors (Continued)

MUX	0	1–10	11–17	18	19	20	31
AO_UI_Source	AO_TB1	PFI<0..9>	RTSI<0..6>	—	TB2	—	GND
AO_UI2_Source	AO_TBL1	PFI<0..9>	RTSI<0..6>	G0_TC	G1_TC	TB2	GND
AO_UI_External_Gate	—	PFI<0..9>	RTSI<0..6>	—	—	—	GND
AO_UI2_External_Gate	—	PFI<0..9>	RTSI<0..6>	—	—	—	GND
Key: AI_ST1 The internal analog input signal START1. AO_TB1. The internal analog output signal AO_IN_TIMEBASE1 G0_TC The G_TC signal from general-purpose counter 0. G1_TC The G_TC signal from general-purpose counter 1. GOUT1 The G_OUT signal from general-purpose counter 1. SW Software strobe TB2 The internal signal IN_TIMEBASE2							



Note *When the analog trigger circuit is enabled, the analog trigger signal takes over the PF10 slot in the PFI selectors.*

3.8.2.1 Using Edge Detection

Use edge detection whenever a one-bit pulse is required but the pulsewidth of the trigger signal cannot be guaranteed. Internally generated triggers are automatically the correct width and need not be edge detected. Software strobes do not have the correct width and should always be edge detected. Edge detection of external signals can usually be performed without affecting the circuit operation.

3.8.2.2 Using Synchronization

Use synchronization whenever the trigger-to-clock timing relationship cannot be guaranteed. Internally generated triggers automatically have the correct timing and need not be synchronized. Software strobes do not have the correct timing and should always be synchronized. Synchronization of external signals results in a one-half bit synchronization delay.

3.8.2.3 Trigger Signals

START1 is the trigger for the waveform generation, initiating the output sequence. It can be generated by software or by an external pulse. START1 can also be internally conditioned to provide enhanced master/slave operation.

3.8.3 Analog Output Counters

The UI counter is a 24-bit binary down counter that generates update interval timing. The UI2 counter is a 16-bit binary down counter that generates a second independent update interval. The UC counter is a 24-bit binary down counter that counts the number of UPDATES. The BC counter is a 24-bit binary down counter that counts the number of cycles or buffers generated; that is, the TC of the UC counter. Notice UI2 does not have associated update or buffer repetition counters. It is primarily intended to be used in an interrupt-driven waveform generation where these functions are provided by software.

The UI counter alternate first period reload modes provide a retriggerable method for obtaining a delay between the trigger signal and the first update pulse which is different than the update interval.

The UI, UI2, UC, and BC counters each has its own control block. The counter control blocks are synchronous control circuits that use the counter mode information, trigger and gate signals, and state of the counter to generate the count enable and load control signals. Figure 3-37 shows the state diagram for the UI control block. Figures 3-38 and 3-39 show the state diagrams for the UC and BC control blocks, respectively.

3.8.3.1 UI Counter

The UI counter is a 24-bit down counter with dual-load registers. The UI counter typically counts the interval between UPDATES, as well as the delay from the initial trigger to the first update. The bitfield AO_UI_Source_Select controls the selection of the UI source clock (UI_SRC). The choices for UI source are AO_IN_TIMEBASE1, PFI<0..9>, RTSI_TRIGGER<0..6>, and IN_TIMEBASE2. The bitfield AO_UI_Source_Polarity selects the polarity of the source clock. The counter load registers are directly accessible from the register map. If the counter is disarmed, AO_UI_Load loads the counter with the value from the selected load register.

During normal operation, the UI counter synchronously reloads from the selected load register following UI_TC. Several options—AO_UI_Reload_Mode, AO_UI_Switch_Load_On_End, AO_UI_Switch_Load_On_Stop, and AO_UI_Switch_Load_On_TC—exist for the UI counter to change the selected load register under various conditions. The options are to alternate load registers once after each STOP, switch load registers on every STOP, alternate load registers once after each BC_TC, switch load registers on every BC_TC, switch load registers on the next BC_TC, switch load registers on the next STOP, and switch load registers on the next UI_TC. The term alternate load registers refers to the action of having one load from the secondary load register and the remaining loads from the primary load register. The UI control circuit generates the count enable signals.

3.8.3.2 UI Control

The UI counter is controlled by a circuit whose state transitions are shown in Figure 3-37. The UI counter control circuit has two states, WAIT and CNT. On power up, the control circuit begins and remains in state WAIT until the counter is armed and a START1 pulse is received. The control circuit then transitions to state CNT and remains there until the count termination condition is reached.

For continuous output modes, the UI counter control circuit can return to state WAIT based on the software strobes AO_End_On_BC_TC and AO_End_On_UC_TC. Also, the UI counter normally remains armed and retriggerable at the end of a scan sequence. The UI counter has the option AO_Trigger_Once to disarm itself when returning to the WAIT state.

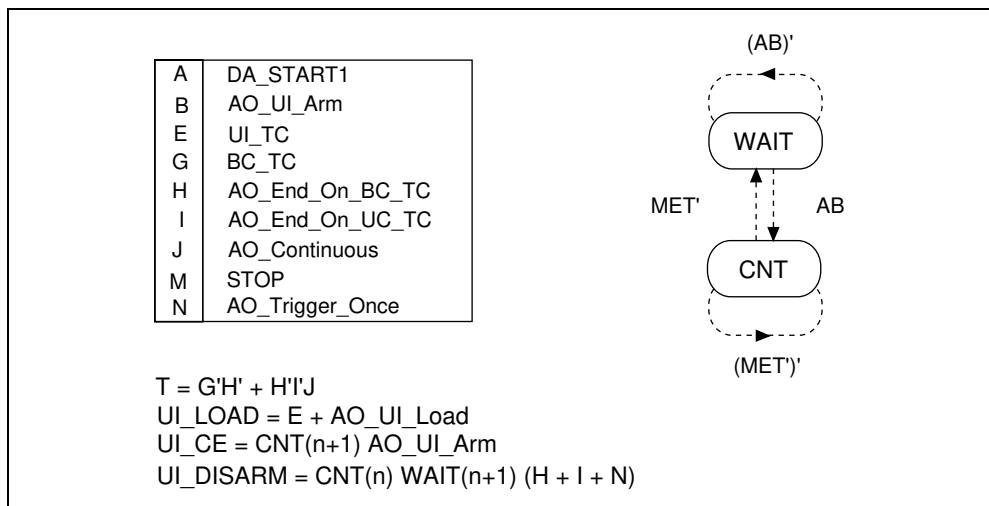

Figure 3-37. UI Control Circuit State Transitions

3.8.3.3 UC Counter

The UC counter is a 24-bit down counter with dual-load registers and output save latch. The UC counter typically counts the number of sample updates contained in a buffer. For this reason, it is referred to as the update counter. The UC counter uses the same clock that is selected for the BC counter BC_SRC. The counter load registers are directly accessible from the register map. If the counter is disarmed, AO_UC_Load loads the counter with the value from the selected load register.

During normal operation, the UC counter synchronously reloads from the selected load register following UC_TC. Two options—AO_UC_Switch_Load_On_End and AO_UC_Switch_Load_On_TC—change the selected load register under various conditions.

The options are to switch load registers on the next BC_TC and switch load registers on the next UC_TC. The UC control circuit generates the count enable signals.

The UC save register latch signal asserts after a rising, then a falling edge of BC_SRC following a 1 being written to AO_UC_Save_Trace. The UC save register latch signal deasserts after a rising, then a falling edge of BC_SRC following a zero being written to AO_UC_Save_Trace.

3.8.3.4 UC Control

The UC counter is controlled by a circuit whose state transitions are shown in Figure 3-38. The UC counter control circuit has two states—WAIT and CNT. On power up, the control circuit begins and remains in the WAIT state until the counter is armed and a START1 pulse is received. When these two events occur, the control circuit moves to the CNT state and the counter begins counting. On UC_TC, the control circuit either remains in CNT or returns to the WAIT state depending on the signals STOP, AO_End_On_BC_TC, AO_End_On_UC_TC, BC_TC, and AO_Continuous.

For continuous acquisition modes, the UC counter control circuit can return to the WAIT state based on the software strobes AO_End_On_BC_TC and AO_End_On_UC_TC. Also, the UC counter normally remains armed and retriggerable at the end of a scan sequence. The UC counter has the option AO_Trigger_Once to disarm itself when returning to the WAIT state.

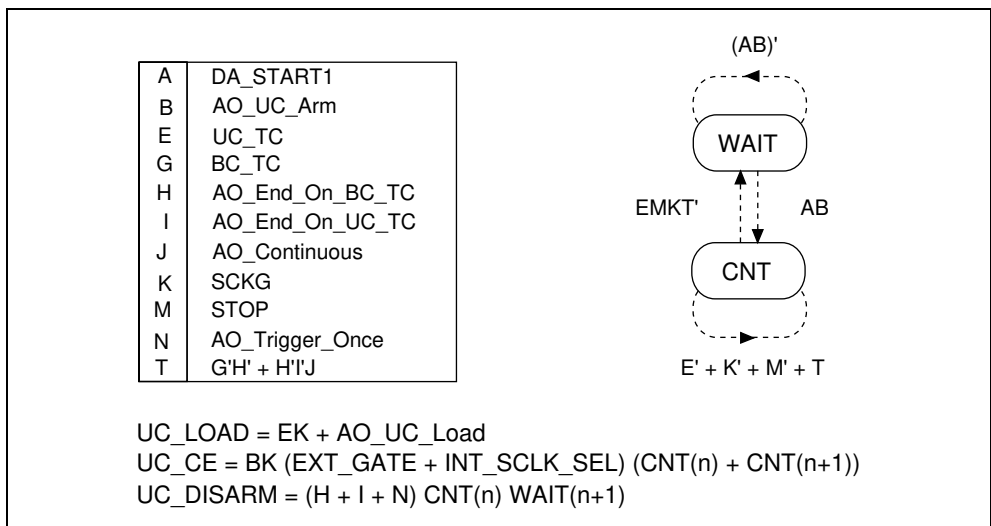

Figure 3-38. UC Control Circuit State Transitions

3.8.3.5 BC Counter

The BC counter is a 24-bit down counter with dual-load registers and output save latch. The BC counter typically counts the number of buffers to be output. The bitfield `AO_BC_Source_Select` controls the `BC_SRC`. The choices for BC source are UPDATE pulses or `UC_TC` pulses. Normally, the BC source is configured to count `UC_TC` pulses. The counter load registers are directly accessible from the register map. If the counter is disarmed, `AO_BC_Load` loads the counter with the value from the selected load register.

During normal operation, the BC counter will synchronously reload from the selected load register following `BC_TC`. Two options—`AO_BC_Reload_Mode` and `AO_BC_Switch_Load_On_TC`—change the selected load register under various conditions. The options are to switch load registers on every `BC_TC` and to switch load registers on the next `BC_TC`. The BC control circuit generates the count enable signals.

The BC save register latch signal asserts after a rising and then a falling edge of `BC_SRC` following a 1 being written to `AO_BC_Save_Trace`. The BC save register latch signal deasserts after a rising, then a falling edge of `BC_SRC` following a zero being written to `AO_BC_Save_Trace`.

3.8.3.6 BC Control

The BC counter is controlled by a circuit whose state transitions are shown in Figure 3-39. The BC counter control circuit has two states—WAIT and CNT. On power up, the control circuit begins and remains in the WAIT state until the counter is armed and a `START1` pulse is received. The control circuit then transitions to the CNT state and remains there until the count termination condition is reached.

The BC counter normally remains armed and retriggerable at the end of a waveform generation sequence. The BC counter has the option `AO_Trigger_Once` to disarm itself after the first `BC_TC`. At the end of a nonretriggerable waveform-generation sequence, the `BC_TC` masks off the last UPDATE pulse to prevent an undesired output.

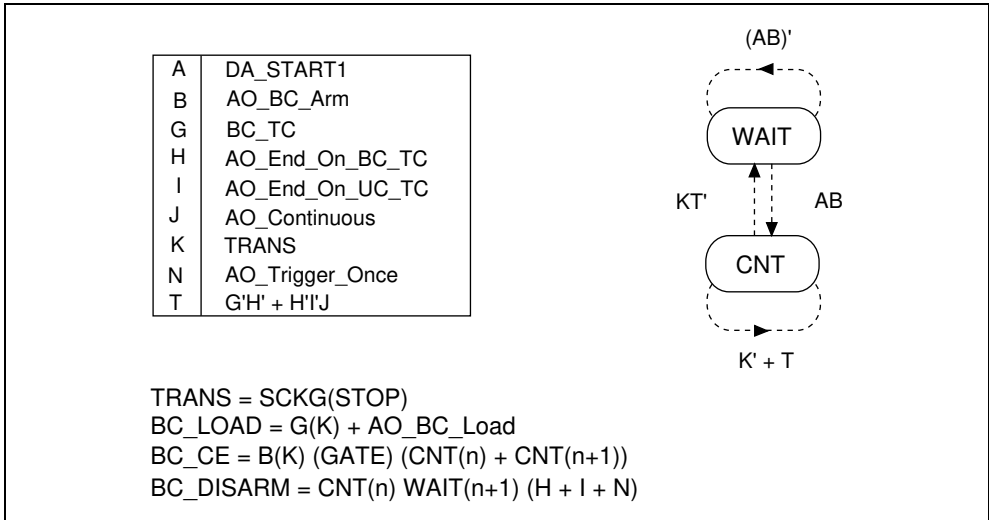

Figure 3-39. BC Control Circuit State Transitions

3.8.3.7 UI2 Counter

The UI2 counter is a 16-bit down counter with dual load registers. The UI2 counter is intended to be used in interrupt-driven waveform generation. The bitfield AO_UI2_Source_Select controls the UI2_SRC. The choices for UI2 source are AO_IN_TIMEBASE1, PFI<0..9>, RTSI_TRIGGER<0..6> and IN_TIMEBASE2. The bitfield AO_UI2_Source_Polarity selects the polarity of the source clock. The counter load registers are directly accessible from the register map. If the counter is disarmed, AO_UI2_Load will load the counter with the value from the selected load register.

During normal operation, the UI2 counter will synchronously reload from the selected load register following UI2_TC. The counter has the option AO_UI2_Reload_Mode to alternate load registers once after every STOP. The UI2 control circuit generates the count enable signals.

3.8.3.8 UI2 Control

UI2 runs unless disarmed, stopped, or gated. The following are the UI2 counter logic equations.

$$UI2_LOAD = UI2_TC + AO_UI2_LOAD$$

$$UI2_CE = AI_UI2_Arm(STOP') (EXT_GATE2 + (DA_SFGATE2') \\ AO_UI2_External_Gate_Enable')$$

3.8.4 Interrupt Control

The analog output contains the hardware necessary for generating software interrupts based on several conditions. The interrupt programming is accomplished using the `Interrupt_B_Enable_Register` and the `Second_Irq_B_Enable_Register`. Interrupts remain active until cleared by software. Interrupts can occur under the following conditions—overrun error, `START1`, `BC_TC`, `UC_TC`, FIFO condition, `UPDATE`, and `UI2_TC`.

Table 3-8 summarizes the analog output interrupts along with the condition that causes the interrupt.

Table 3-8. Analog Output Interrupts

Interrupt	Condition
Error Interrupt	Interrupt generated on the detection of an overrun error condition.
<code>START1</code> Interrupt	Interrupts are generated on valid <code>START1</code> triggers received by the DAQ-STC. A valid <code>START</code> trigger is one that is received while the <code>BC</code> counter is armed and in the <code>WAIT1</code> state.
<code>BC_TC</code> Interrupt	Interrupts are generated on the trailing edge of <code>BC_TC</code> .
<code>UC_TC</code> Interrupt	Interrupts are generated on the leading edge of <code>UC_TC</code> .
FIFO Interrupt	Interrupt generated on the FIFO condition indicated by the <code>AO_FIFO_Mode</code> bitfield.
<code>UPDATE</code> Interrupt	Interrupts are generated on the trailing edge of <code>UPDATE</code> .
<code>UI2_TC</code> Interrupt	Interrupts are generated on the trailing edge of <code>UPDATE2</code> .

3.8.5 Error Detection

The DAQ-STC can detect error conditions that occur during the analog output operation. There are three primary analog output errors—overrun, `BC_TC`, and `BC_TC` trigger, and one secondary analog output error—`UI2_TC` error.

3.8.5.1 Overrun Error

An overrun error occurs when an `UPDATE` command is issued to a DAC that was not loaded with data. In hardware, this is detected when an `UPDATE` pulse occurs before all of the `TMRDACWR` pulses from the previous `UPDATE` have completed. The `TMRDACWR` pulses from the previous `UPDATE` may not have completed for several reasons, such as interference from CPU writes to the DACs, an `UPDATE` interval that is too short, or a FIFO empty condition that delays `TMRDACWR`.

3.8.5.2 BC_TC Error

During waveform staging for primary analog output, software loads the parameters for each MISB during the previous MISB. The software must complete this programming operation before the end of the current MISB. A BC_TC error occurs when the parameters for the next MISB are not written in the allotted time. The error-detection circuit is armed on each BC_TC. If a software clear, AO_BC_TC_Interrupt_Ack, does not occur before the next BC_TC, the error-detection circuit latches an error condition.

3.8.5.3 BC_TC Trigger Error

The BC_TC trigger error is used in retriggerable waveform staging. In retriggerable waveform staging, a START1 trigger that occurs after the first waveform staging sequence completes causes a new waveform staging sequence to begin. The software must have time to program the next waveform staging sequence between the completion of the previous waveform staging sequence and the START1 trigger. A BC_TC trigger error occurs when the parameters for the next waveform staging sequence are not written in the allotted time. The error-detection circuit is armed on the last BC_TC of the waveform staging sequence. If a software clear, AO_BC_TC_Interrupt_Ack, does not occur before the next START1 trigger, the error-detection circuit latches an error condition.

3.8.5.4 UI2_TC Error

During waveform staging for secondary analog output, software loads the parameters for the next update interval during the previous update interval. The software must complete the programming operation before the end of the current update interval. A UI2_TC error occurs when the parameters for the next update interval are not written in the allotted time. The error-detection circuit is armed on each UI2_TC. If a software clear, AO_UI2_TC_Interrupt_Ack, does not occur before the next BC_TC, the error-detection circuit latches an error condition.

3.8.6 Output Control

The AOTM also contains hardware for generating the necessary output signals. This hardware performs the following operations:

- Generates the update signals UPDATE and UPDATE2 and controls their width and polarity
- Generates the DAQ-STC writes to DAC signals TMRDACWR, DACWR<1..0>, and LDAC<1..0>
- Conditions the CPU writes to DAC signal CPUDACWR
- Arbitrates the DAQ-STC and CPU write signals to prevent local bus conflict
- Generates the bus extend request signal to the CPU CHRDY_OUT

- Generates the DAC address up to 16 DAC channels
- Generates the AOFFRT signal
- Generates the AOFREQ signal

The bitfield AO_UPDATE_Output_Select controls the output UPDATE. The output can be one of high impedance, ground, output enabled, or output enabled and inverted. When enabled, the signal pulses to update the DAC.

The bitfield AO_UPDATE2_Output_Select controls the output UPDATE2. The output can be one of high impedance, ground, output enabled, or output enabled and inverted. When enabled, the signal also pulses to update the DAC.

3.8.7 Nominal Signal Pulsewidths

Table 3-9 lists the nominal pulsewidths for the signals associated with analog input. Notice that only the UPDATE and UPDATE2 signals can use either the source or output clocks; all of the others must use the indicated clock source. These are only the nominal pulsewidths; the actual synchronization edges and propagation delays are detailed in section 3.7, [Timing Diagrams](#)

Table 3-9. Analog Output Nominal Signal Widths

Signal	Source Clock	Output Clock
UPDATE	1	1, 3
UPDATE2	1	1, 3
LDAC0	1	1, 3
LDAC1	1	1, 3
TMRDACWR	—	2, 3
CPUDACWR	—	2, 3
TMRDACREQ	Asserted when data needed, removed at TMRDACWR.	
AO_ADDR<0..3>	Changes on trailing edge of TMRDACWR. Bus address pass through during CPUDACWR.	
CHRDY_OUT	From CPUDACREQ to edge of CPUDACWR.	
DACWR0	—	2, 3
DACWR1	—	2, 3
AOFFRT	—	1

General-Purpose Counter/Timer

4.1 Overview

This chapter presents information about the general-purpose counter/timer (GPCT) module of the DAQ-STC. The GPCT consists of two independent 24-bit up/down counters, each with associated load and save registers, and a control structure for implementing some common counting and timing I/O functions. These timing functions include period measurement, pulsewidth measurement, event counting, single-pulse generation, and pulse-train generation with programmable frequency and duty cycle (the percentage of the cycle that the pulse is high). Most functions can operate using only one general-purpose counter. There are two modes of operation for the measurement functions—single mode and buffered mode. In single mode, the functions obtain only one measurement. In buffered mode, the functions obtain a series of consecutive, gap-free measurements.

You can select the GPCT input signals from any of the 17 external timing I/O pins on the DAQ-STC. Ten of these PFI lines are user-programmable I/O pins and are available on the I/O connector of the MIO-E Series boards. The remaining seven of the external timing I/O pins connect to the RTSI bus. Refer to Chapter 5, *Programmable Function Inputs*, and Chapter 6, *RTSI Trigger*, for more information on the timing I/O pins.

The two counters are identical except for the internal routing of the counter outputs. Refer to section 4.8, *Detailed Description*, for more information on the routing of the counter outputs.

4.1.1 Programming the GPCT

To program the GPCT module of the DAQ-STC, read sections 4.2, *Features*, through 4.6, *Programming Information*. As you read the *Programming Information* section, you will need to refer to section 4.7, *Timing Diagrams*. You will also need to consult the register-level programmer manual for the hardware containing the DAQ-STC.

4.2 Features

The GPCT module has the following features:

- Two independent 24-bit binary up/down counters
- Count up/count down control via hardware or software
- Programmable counter source and gate selection from 17 signal sources

- Programmable input and output signal polarities
- One-shot, continuous, or tri-state output
- Two banks of dual-load registers that allow seamless frequency and duty cycle changes during double-buffered pulse-train generation
- A counter load register that can increment or decrement on TC, which allows for equivalent time sampling (ETS) timing output. ETS is a sampling method for repetitive waveforms where the sample point is moved within the cycle. Refer to section 4.4.4.5, *Pulse Generation for ETS*, for more information.
- Interevent (relative) time stamping
- Two sets of save registers to save the counter value via an external control signal or via software command
 - Current count value can be read without affecting circuit operation
- Bus interface support
 - Interrupts based on TC or on active gate edge—rising edge, falling edge, or any edge
 - Secondary interrupts to facilitate a DMA or local CPU interface for timing functions
- *Not* supported in hardware are BCD counting and time-of-day counting

4.3 Simplified Model

The GPCT module contains two identical 24-bit binary up/down counters—general-purpose counters 0 and 1. Figure 4-1 shows a simplified model of the counter.

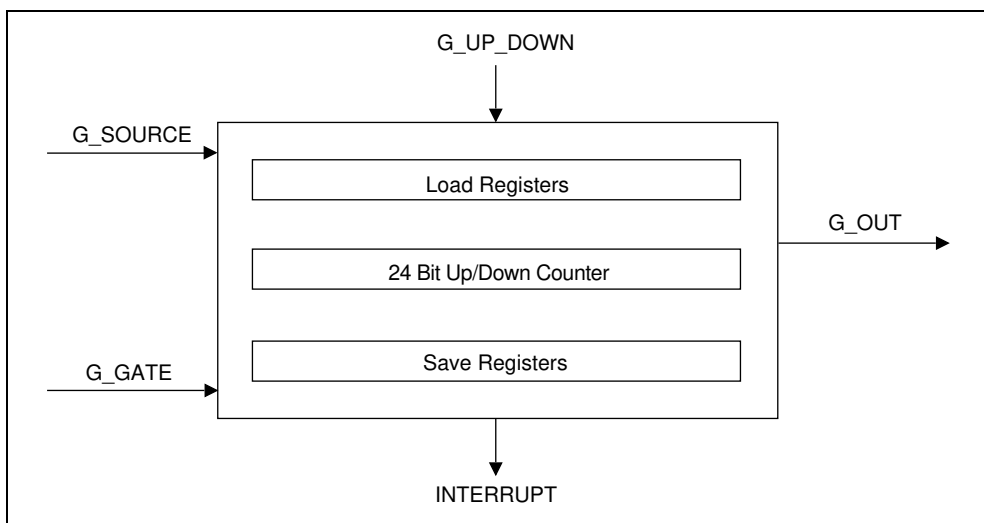

Figure 4-1. General-Purpose Counter/Timer Simplified Model

Each GPCT counter has a source input (G_SOURCE), a gate input (G_GATE), and an up/down control input (G_UP_DOWN). When the counter is enabled to count, rising edges on the G_SOURCE input cause the counter to increment or decrement. The G_GATE input acts as a general-purpose control signal and can operate as a counter trigger signal, a counter enable, a save signal, a reload signal, an interrupt, an output control signal, a load register select signal, and a counter disarm. The G_UP_DOWN input determines whether the counter counts up or down.

The counter outputs are the signals labeled G_OUT and INTERRUPT. G_OUT is a counter TC-related signal, which can toggle on every counter TC or can output the counter TC signal directly. INTERRUPT is an interrupt signal routed inside the DAQ-STC to the interrupt control module. Refer to Chapter 8, *Interrupt Control*, for more information. The counter has load registers to reload the counter with new count values. The save registers save the counter contents until they can be read by software.

4.4 Counter/Timer Functions

The purpose of the GPCT is to provide counter/timer functions that are improved over those available on the Am9513-based DAQ boards through NI-DAQ, the National Instruments software for data acquisition. Examples of existing counter/timer functions supported by the DAQ-STC are event counting, period measurement, pulsewidth measurement, pulse generation, and pulse-train generation. Enhancements to the existing counter/timer functions include ETS timing output, relative time stamping, and the ability to perform buffered mode operations.

4.4.1 Event Counting

In the event-counting functions, the counter counts events on the G_SOURCE input following the software arm. The software arm occurs when software sets the counter arm bit in the DAQ-STC register map. The following actions are available in event counting:

- G_SOURCE increments or decrements the counter.
- G_GATE indicates when to start and stop counting intervals or when to save the counter contents in the save register.
- The software either reads the counter value asynchronously or reads the save register each time the hardware latches the counter value. In the latter case, interrupts notify the software that a save has occurred.
- G_UP_DOWN controls the direction of the counting.

4.4.1.1 Simple Event Counting

In simple event counting, the counter counts the number of pulses that occur on the G_SOURCE signal after the software arm. Software can read the counter contents at any time without disturbing the counting process. Figure 4-2 shows an example of simple event counting where the counter counts five events on G_SOURCE.

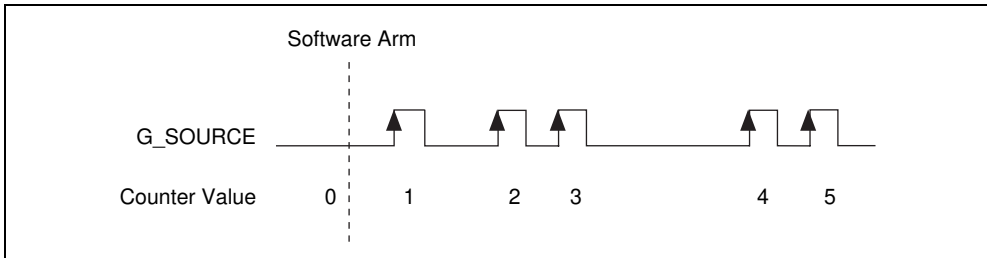

Figure 4-2. Simple Event Counting

4.4.1.2 Simple Gated-Event Counting

Simple gated-event counting is similar to simple event counting except that the counting process is gated; that is, halted and resumed via G_GATE. When G_GATE is active, the counter counts pulses that occur on the G_SOURCE signal after the software arm. When G_GATE is inactive, the counter retains the current count value. Figure 4-3 shows an example of simple gated-event counting where the gate action allows the counter to count only five of the pulses on G_SOURCE.

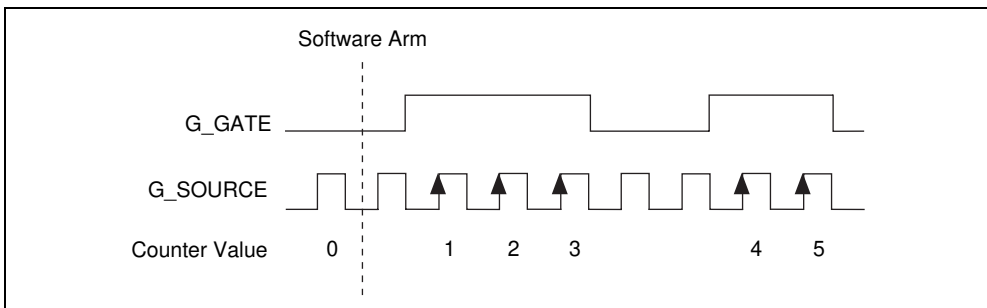

Figure 4-3. Simple Gated-Event Counting

4.4.1.3 Buffered Noncumulative Event Counting

Buffered noncumulative event counting is similar to simple event counting except that there are multiple counting intervals. The G_GATE signal indicates the boundary between consecutive counting intervals. The counter counts the number of pulses that occur on the

G_SOURCE signal after the software arm. Each active edge of the G_GATE signal latches the count value for the current counting interval into the hardware (HW) save register and reloads the counter with the initial value to begin the next counting interval. An interrupt notifies the CPU after each counting interval so that the interrupt software can read the result from the HW save register. Figure 4-4 shows buffered noncumulative event counting with two counting intervals. Three events are counted in each of the two counting intervals.

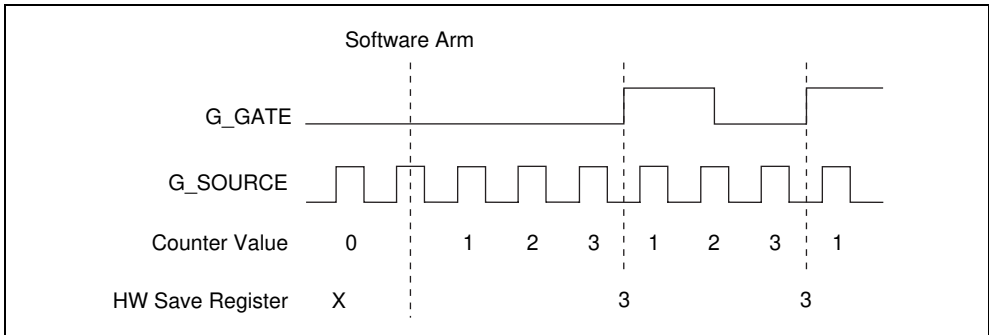

Figure 4-4. Buffered Noncumulative Event Counting

4.4.1.4 Buffered Cumulative Event Counting

Buffered cumulative event counting is similar to simple event counting except that the G_GATE signal indicates when to save the counter value to the HW save register. The active G_GATE edge latches the count value into the HW save register. Counting continues uninterrupted regardless of the G_GATE activity. An interrupt notifies the CPU after each active G_GATE edge so that the interrupt software can read the result from the HW save register. Figure 4-5 shows cumulative event counting where the gate action causes the HW save register to save the counter contents twice.

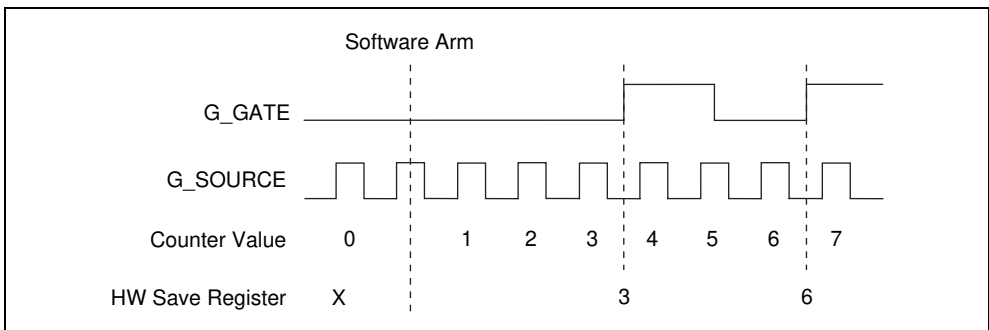

Figure 4-5. Cumulative Event Counting

4.4.1.5 Relative Position Sensing

In relative position sensing, the counter tracks the relative position of an object. Two types of events are possible—movement in the positive direction and movement in the negative direction. The positive movement event is an active edge transition on the G_SOURCE input while G_UP_DOWN is high. The negative movement event is an active edge transition on the G_SOURCE input while G_UP_DOWN is low. The software initially loads the counter with a value corresponding to the initial position of the object. Positive movement events cause the counter to increment and negative movement events cause the counter to decrement. Upon reaching TC, the counter rolls over. The user can obtain the relative position of the object at any time by asynchronously reading the counter value. Figure 4-6 shows an example of relative position sensing.

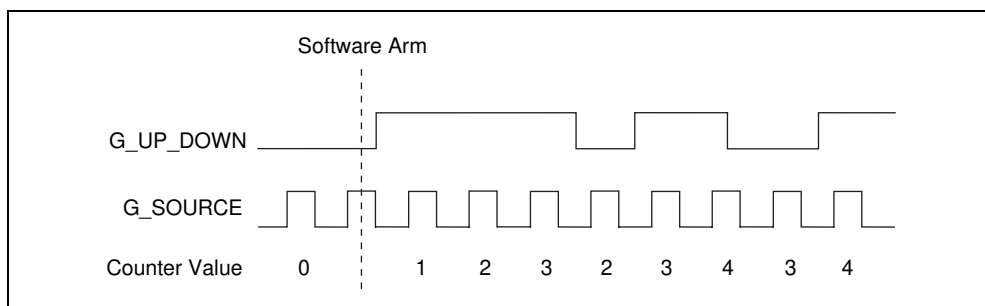

Figure 4-6. Relative Position Sensing

4.4.2 Time Measurement

In the time-measurement functions, the counter uses G_SOURCE as a timebase to measure the time interval between events on the G_GATE signal. The following actions are available in time measurement:

- Rising edges on G_SOURCE can increment or decrement the counter during the measurement interval.
- Counting can begin and end on any two of the G_GATE edges—active, inactive, or either.
- The HW save register can save the counter value upon the completion of the measurement.

4.4.2.1 Single-Period Measurement

In single-period measurement, the counter uses G_SOURCE to measure the period of the signal present on the G_GATE input. The counter counts the number of rising edges that occur on G_SOURCE between two active edges of G_GATE. At the completion of the period interval for G_GATE, the HW save register latches the counter value for software read.

Figure 4-7 shows a single-period measurement where the period of G_GATE is five G_SOURCE rising edges.

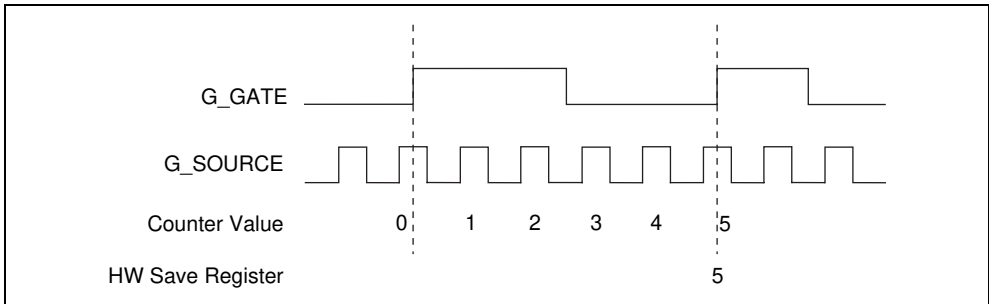

Figure 4-7. Single-Period Measurement

4.4.2.2 Single-Pulsewidth Measurement

In single-pulsewidth measurement, the counter uses G_SOURCE to measure the pulsewidth of the signal present on the G_GATE input. The counter counts the number of rising edges that occur on G_SOURCE while the G_GATE signal remains in an active state. At the completion of the pulsewidth interval for G_GATE, the HW save register latches the counter value for software read. Figure 4-8 shows a single-pulsewidth measurement where the pulsewidth of G_GATE is five G_SOURCE rising edges.

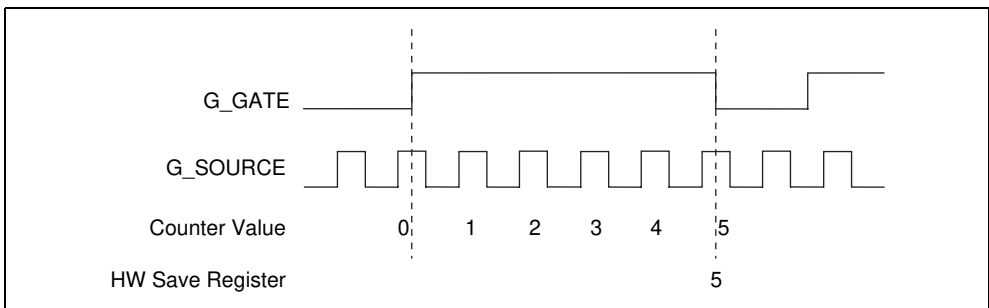

Figure 4-8. Single-Pulsewidth Measurement

4.4.2.3 Buffered Period Measurement

Buffered period measurement is similar to single-period measurement, except that measurements are taken for multiple periods. The counter uses G_SOURCE to measure the time interval between two active edges of the signal present on the G_GATE input, counting the number of rising edges that occur on G_SOURCE between each pair of active edges of G_GATE. At the completion of each period interval for G_GATE, the HW save register

latches the counter value for software read. An interrupt notifies the CPU after each period so that the interrupt software can read the value in the HW save register. Figure 4-9 shows two periods of a buffered period measurement where the period is three G_SOURCE rising edges.

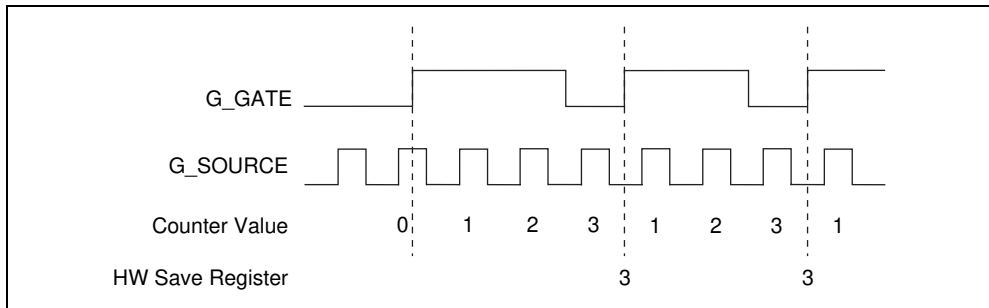

Figure 4-9. Buffered Period Measurement

4.4.2.4 Buffered Semiperiod Measurement

Buffered semiperiod measurement is similar to buffered period measurement, except that the measurements are taken over every semiperiod. The counter uses G_SOURCE to measure each half-period of the signal present on the G_GATE input, counting the number of rising edges that occur on G_SOURCE while G_GATE remains in an active and in an inactive state. At the completion of each semiperiod interval for G_GATE, the HW save register latches the count value for software read. An interrupt notifies the CPU after each semiperiod so that the interrupt software can read the value in the HW save register. Figure 4-10 shows three semiperiods of a buffered semiperiod measurement where the first semiperiod is three G_SOURCE rising edges, the second semiperiod is one G_SOURCE rising edge, and the final semiperiod is two G_SOURCE rising edges. Notice that you do not know whether the first value is saved on a rising edge or a falling edge.

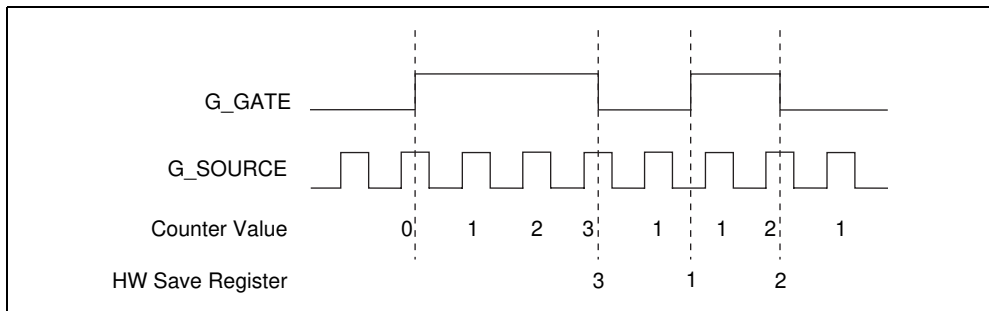

Figure 4-10. Buffered Semiperiod Measurement

4.4.2.5 Buffered Pulsewidth Measurement

Buffered pulsewidth measurement is similar to single-pulsewidth measurement, except that the measurements are taken over multiple pulses. The counter uses G_SOURCE to measure the pulsewidth of the signal present on the G_GATE input, counting the number of rising edges that occur on G_SOURCE while G_GATE remains in an active state. At the completion of each pulsewidth interval for G_GATE, the HW save register latches the counter value for software read. An interrupt notifies the CPU after each period so that the interrupt software can read the value in the HW save register. Figure 4-11 shows two pulsewidths of a buffered pulsewidth measurement where the first pulsewidth is three G_SOURCE rising edges and the second pulsewidth is two G_SOURCE rising edges.

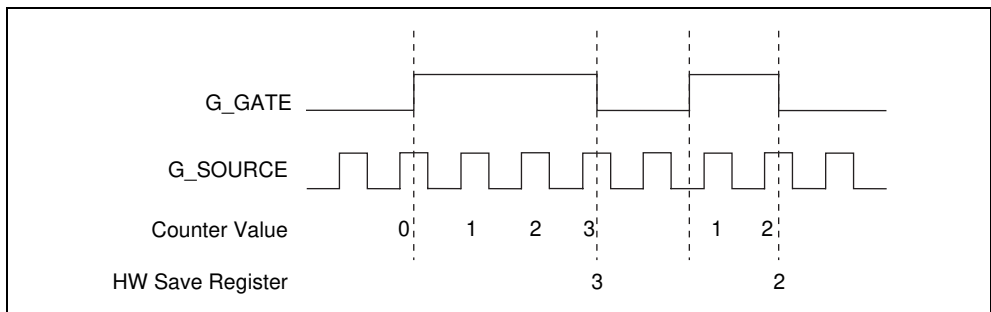

Figure 4-11. Buffered Pulsewidth Measurement

4.4.3 Pulse Generation

In the pulse generation functions, the counter generates a single pulse of specified duration following the software arm. The software arm occurs when software sets the counter arm bit in the DAQ-STC register map. The following actions are available in pulse generation:

- The counter uses G_SOURCE as a timebase to generate the pulse.
- The user specifies the pulse parameters in terms of periods of the G_SOURCE input.
- G_GATE can serve as a trigger signal to generate a pulse after the first active gate edge, or after each active gate edge.
- An alternate output mode is provided so that G_OUT outputs two counter TC pulses, instead of a single long pulse.

4.4.3.1 Single Pulse Generation

The single pulse generation function generates a single pulse with programmable delay and programmable pulsewidth following the software arm. The counter uses G_SOURCE as a timebase to generate the pulse, so you specify the pulse parameters in terms of periods of the G_SOURCE input. Software implements pulse generation by loading the delay value into the counter, loading the pulsewidth value into the load register, and programming the counter

output G_OUT to change states on counter TC. Figure 4-12 shows the generation of a single pulse with a pulse delay of four and a pulsewidth of three.

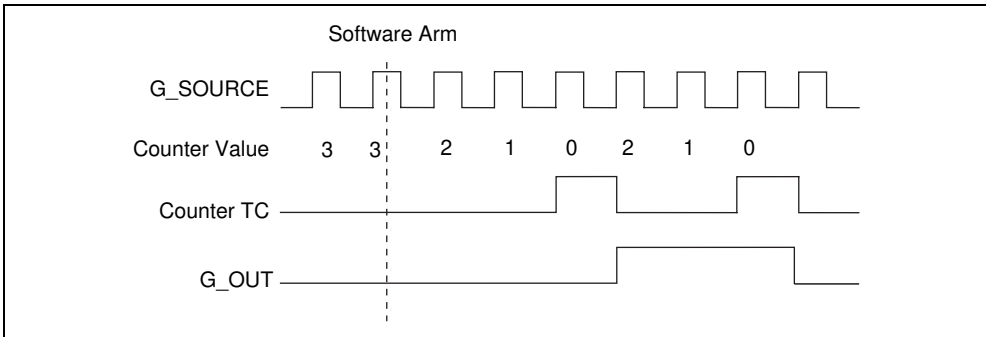

Figure 4-12. Single Pulse Generation

4.4.3.2 Single Triggered Pulse Generation

Single triggered pulse generation is similar to single pulse generation except that G_GATE provides a trigger function. An active G_GATE edge following the software arm causes the counter to generate a single pulse with programmable delay and programmable pulsewidth. You should specify the programmable parameters in terms of periods of the G_SOURCE input. Single triggered pulse generation is implemented in software by loading the delay value into the counter, loading the pulsewidth value into the load register, programming the counter output G_OUT to change states on counter TC, and configuring G_GATE to be the trigger signal. Figure 4-13 shows the generation of a single pulse with a pulse delay of four and a pulsewidth of three.

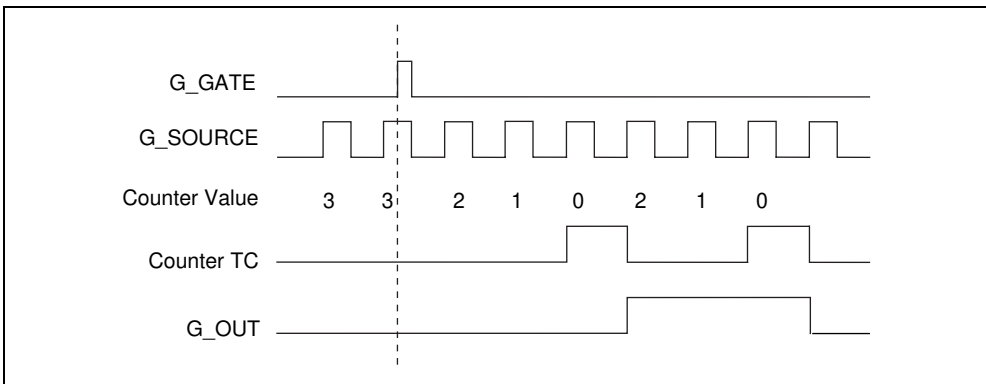

Figure 4-13. Single Triggered-Pulse Generation

4.4.3.3 Retriggerable Single Pulse Generation

This function is similar to single triggered pulse generation except that the counter generates a pulse on every active G_GATE edge following the software arm instead of only on the first occurrence. After the counter arm, every active G_GATE edge causes the counter to generate a single pulse with programmable delay and programmable pulsewidth. You should specify the programmable parameters in terms of periods of the G_SOURCE input. Retriggerable single pulse generation is implemented in software by loading the delay value into the counter, loading the pulsewidth value into the primary load register, programming the counter output G_OUT to change states on counter TC, and configuring the counter to trigger on every G_GATE. Figure 4-14 shows the generation of two pulses with a pulse delay of five and a pulsewidth of three.

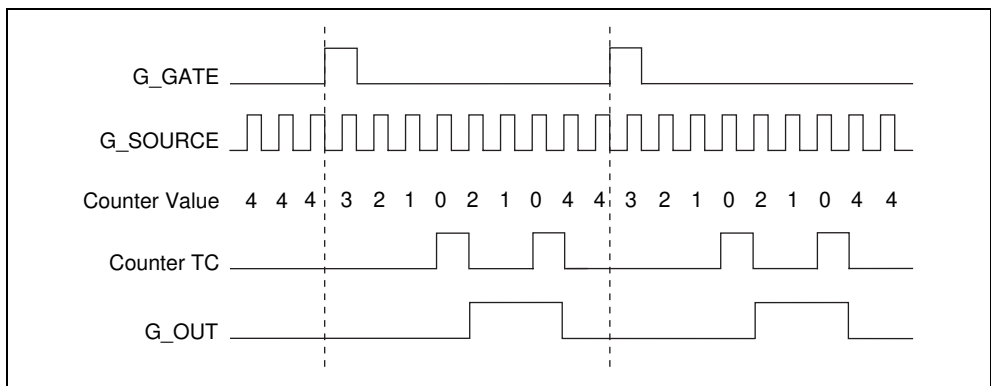

Figure 4-14. Retriggerable Single Pulse Generation

4.4.3.4 Buffered Retriggerable Single Pulse Generation

This function is similar to retriggerable single pulse generation except that the software updates the pulse parameters after the generation of each pulse. Following the software arm, every active G_GATE edge causes the counter to generate a single pulse with programmable delay and programmable pulsewidth. You should specify the programmable parameters in terms of periods of the G_SOURCE input. After each pulse, an interrupt notifies the CPU so that the interrupt software can load the counter registers with the parameters for the next pulse. Dual load registers provide additional software programming flexibility. Figure 4-15 shows the generation of two buffered pulses. The first pulse has a pulse delay of five and a pulsewidth of three. The second pulse has a pulse delay of six and a pulsewidth of four.

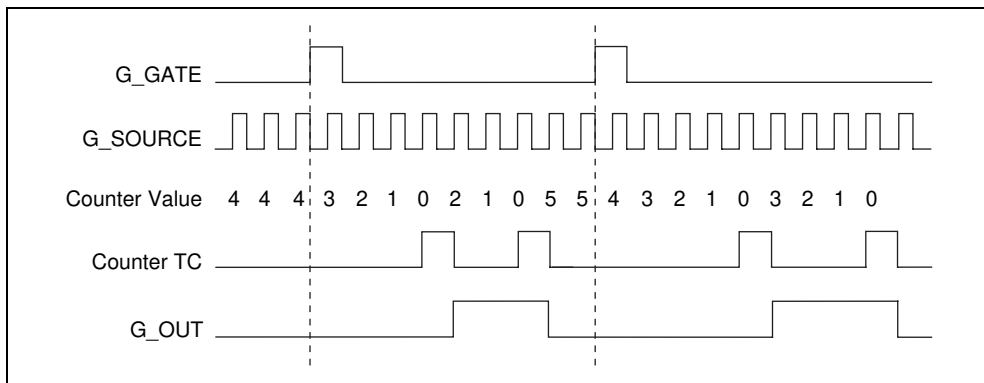

Figure 4-15. Buffered Retriggerable Single Pulse Generation

4.4.4 Pulse-Train Generation

In the pulse-train generation functions, the counter generates a continuous stream of pulses of specified interval and duration following the software arm and an optional hardware trigger. The software arm occurs when software sets the counter arm bit in the DAQ-STC register map. The following actions are available in pulse-train generation:

- Specify the pulse parameters in terms of periods of the G_SOURCE input.
- The G_GATE input can serve as a trigger signal to generate a stream of pulses only after the active gate edge occurs.
- The hardware provides an alternate output mode so that G_OUT outputs two counter TC pulses, instead of a single-long pulse.

4.4.4.1 Continuous Pulse-Train Generation

This function generates a sequence of pulses with programmable delay from trigger, pulse interval, and pulsewidth. The counter uses G_SOURCE as a timebase to generate the pulses, so you specify the programmable parameters in terms of periods of the G_SOURCE input. Pulse-train generation is implemented in software by loading the pulse parameters into the counter and load registers, and by programming the counter to switch load registers on every counter TC. Figure 4-16 shows the generation of three pulses with a delay from trigger of three, a pulse interval of four and a pulsewidth of three.

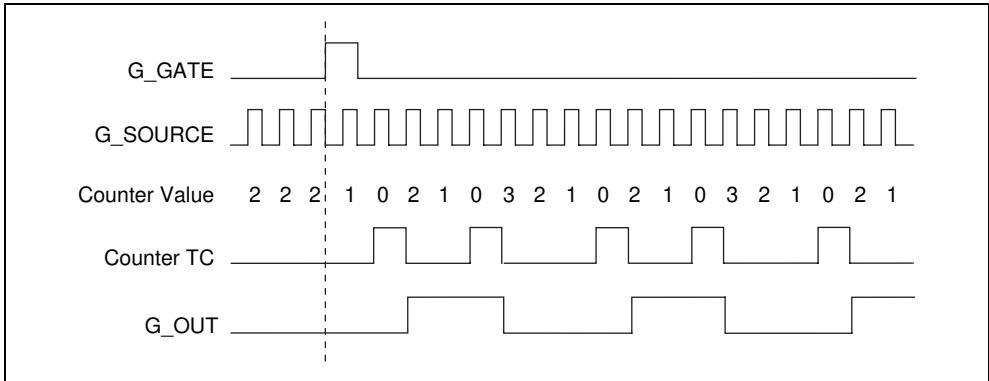

Figure 4-16. Continuous Pulse-Train Generation

4.4.4.2 Buffered Static Pulse-Train Generation

This function is similar to continuous pulse-train generation except that the software maintains a software count of the number of pulses that have been generated and stops the pulse generation after a predetermined number of pulses. The G_GATE active edge causes the counter to generate a sequence of pulses with programmable delay from trigger, pulse interval, and pulsewidth. The counter uses G_SOURCE as a timebase to generate the pulses, so you specify the programmable parameters in terms of periods of the G_SOURCE input. After each pulse, an interrupt notifies the CPU so that the interrupt software can increment the software pulse counter. After the desired number of pulses have been output, the software terminates the pulse generation. Figure 4-17 shows the generation of three pulses with a delay from trigger of three, a pulse interval of four and a pulsewidth of three.

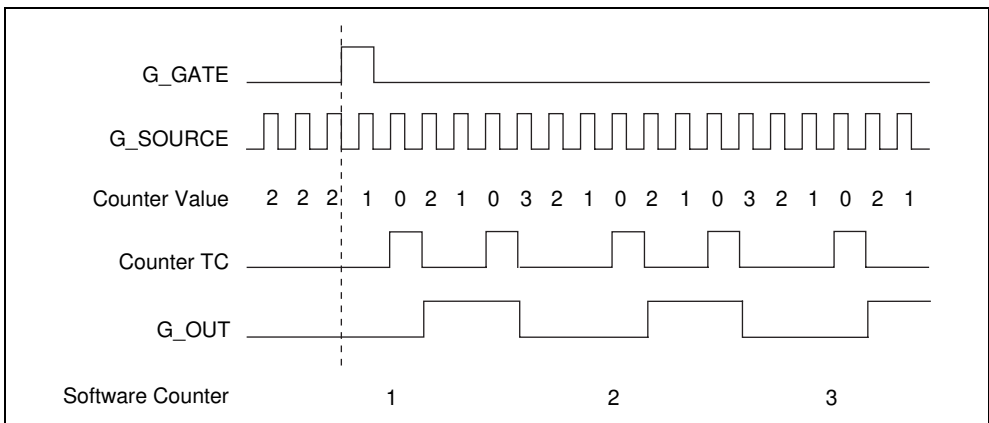

Figure 4-17. Buffered Static Pulse-Train Generation

4.4.4.3 Buffered Pulse-Train Generation

This function is similar to buffered static pulse-train generation except that the software changes the pulse parameters after the generation of each pulse. The G_GATE active edge causes the counter to generate a sequence of pulses with programmable delay from trigger, pulse interval, and pulsewidth. The counter uses G_SOURCE as a timebase to generate the pulses, so you specify the programmable parameters in terms of periods of the G_SOURCE input. After each pulse, an interrupt notifies the CPU so that the interrupt software can load the parameters for the next pulse into the counter registers. Dual-load registers provide additional software programming flexibility. Figure 4-18 shows the generation of three pulses. The first pulse has a delay from trigger of three and a pulsewidth of three. The second pulse has a pulse interval of four and a pulsewidth of two. The third pulse has a pulse interval of three and a pulsewidth of four.

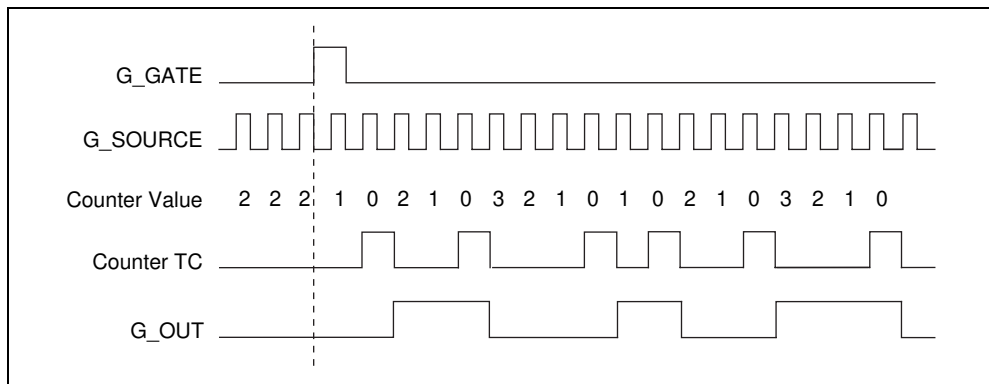

Figure 4-18. Buffered Pulse-Train Generation

4.4.4.4 Frequency Shift Keying (FSK)

FSK is similar to pulse-train generation in that the counter generates a train of pulses. However, in FSK mode the G_GATE signal modulates the frequency and duty cycle of the output train. The GPCT module implements frequency modulation by allowing the G_GATE signal to select the load registers. Figure 4-19 shows an example of FSK. When G_GATE is low, the counter generates a low-frequency signal with a long pulsewidth. When G_GATE is high, the counter generates a high-frequency signal with a short pulsewidth.

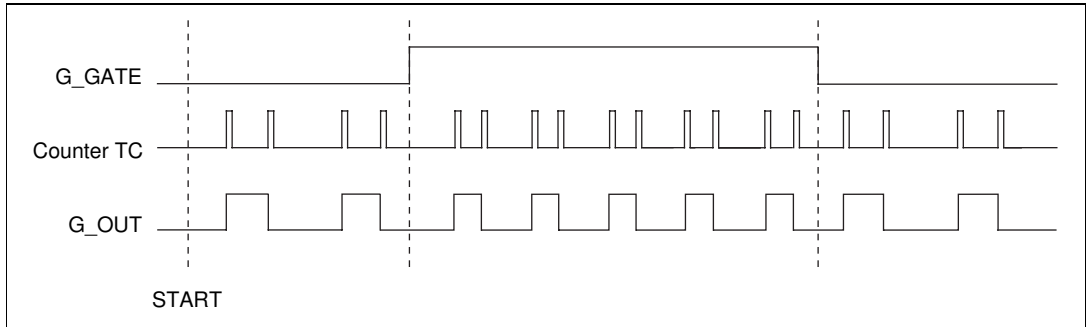

Figure 4-19. Frequency Shift Keying

4.4.4.5 Pulse Generation for ETS

In pulse generation for ETS, the counter produces a pulse on the output a specified delay after the first G_GATE active edge. After each successive G_GATE active edge, the counter automatically increments or decrements the delay from G_GATE. This type of waveform can be used in under-sampling applications where a digitizing system can sample repetitive waveforms that are higher in frequency than the Nyquist frequency of the system. For this application, the bandwidth of the track-and-hold limits the useful frequency range, not the A/D converter. The incremental delay parameter is 8-bits wide. On every other counter TC, the counter reloads with the sum of the load register and the 8-bit incremental delay parameter. The counter then stops and waits for the next G_GATE active edge. This continues until the software issues a disarm command. After each recognized edge of G_GATE, the counter ignores further edges on G_GATE until the second counter TC. Figure 4-20 shows an example of pulse generation for ETS. In this figure, the delay from the trigger to the pulse increases after each subsequent G_GATE active edge.

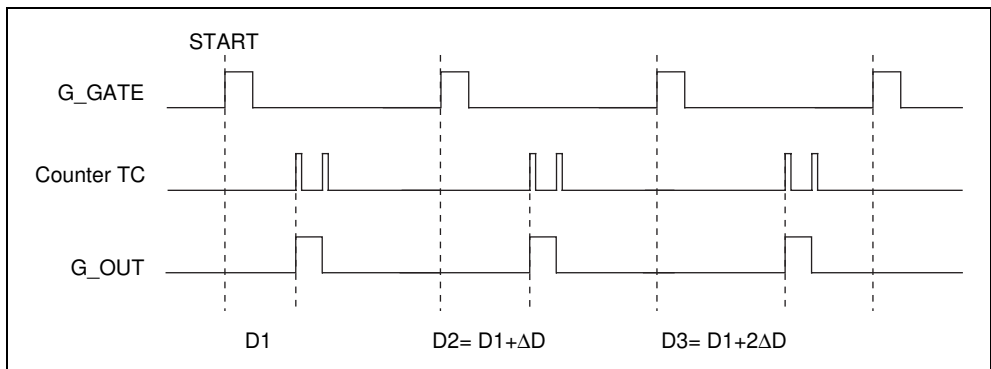

Figure 4-20. Pulse Generation for ETS

4.5 Pin Interface

The I/O pins relevant to the counter/timer are listed in the following table. Although the PFI<0..9> and RTSI_TRIGGER<0..6> pins can be used to input and source GPCT related signals, these pins are discussed in Chapter 5, *Programmable Function Inputs*, and Chapter 6, *RTSI Trigger*, and are not listed in this table.

Pin Type Notation:

IU	TTL input, pull down (50 k Ω)
IU	TTL input, pull up (50 k Ω)
B9TU	Bidirectional, 9 mA sink, 5 mA source tri-state, pull up (50 k Ω)
O9TU	Output, 9 mA sink, 5 mA source tri-state, pull up (50 k Ω)

Pin Name	Type	Description
G_OUT0/RTSI_IO	B9TU	Counter 0 Output/RTSI IO—Programmed as an input, this pin provides a path to the RTSI_TRIGGER<0..6> selectors. Programmed as an output, this pin can output the G_OUT signal from general-purpose counter 0 or it can output the signal present on one of the RTSI_TRIGGER<0..6> lines. Related bitfields: GPFO_0_Output_Select, GPFO_0_Output_Enable, Gi_Output_Mode, Gi_Output_Polarity.
G_OUT1/DIV_TC_OUT	O9TU	Counter 1 Output/DIV Counter Terminal Count—This pin can output the G_OUT signal from general-purpose counter 1 or it can output the internal signal EXT_DIVTC from the AITM for compatibility with an SCXI scan mode. Related bitfields: GPFO_0_Output_Select, GPFO_0_Output_Enable, Gi_Output_Mode, Gi_Output_Polarity.
G_UP_DOWN<0..1>	ID/IU	Up/Down Controls—These pins are the dedicated up/down controls for the GPCTs. When selected for counter control, logic low indicates count down and logic high indicates count up. These pins are pulled down on the first revision of the DAQ-STC, and pulled up on later revisions. See Appendix D, <i>DAQ-STC Revision History</i> , for DAQ-STC revision information. Related bitfields: Gi_Up_Down.

4.6 Programming Information

This section presents programming information specific to the GPCT module. For general information about programming the DAQ-STC, see section 2.6, *Programming Information*.

4.6.1 Programming for a GPCT Operation

This section will give programming sequences you should perform if you want to use the features of the DAQ-STC general-purpose counters. The programming sequences will be developed in a bottom-up fashion, so that reading this section from the beginning to the end will give you overview of the full functionality of the DAQ-STC general-purpose counters. If you are interested in a specific application, you should feel free to skip over parts of the text that you find irrelevant.

Most of the programming sequences presented here must be executed exactly as shown.

Bitfield assignment is a pseudocode instruction of the form *<bitfield name> = <value>*.

Pseudocode sequences enclosed in braces that contain only bitfield assignments can normally be executed in any order, or simultaneously, if possible. If the sequence must be executed in the exact order, the character Σ marks the boundary between two groups of assignments that have to be executed sequentially. For example, in the following pseudo-code, the first bitfield assignment must be performed first; the second and third assignments may then be executed in any order, but the fourth bitfield assignment must be executed after the second and the third bitfield assignments. Other programming constructs, such as if-then, should be executed in the order shown.

```
{
  FOUT_Enable = 0;
  Σ
  FOUT_Timebase_Select = 0 (FOUT_IN_TIMEBASE1) or 1 (IN_TIMEBASE2);
  FOUT_Divider = 0 (for division factor 16) or 1-15 (for division factor 1-15);
  Σ
  FOUT_Enable = 1;
}
```

4.6.1.1 Overview

The DAQ-STC contains two general-purpose counters—general-purpose counter 0 and general-purpose counter 1. The two general-purpose counters are designed to be used in various applications.

Each general-purpose counter is equipped with two save registers and two banks of load registers. Every bank of load registers contains two load registers. The two banks of load registers are called bank X and bank Y. The two load registers in each bank are called load register A and load register B. The two save registers are used for saving the contents of the counter; they are called the HW save register and the save register.

4.6.1.2 Notation

In this section, G_i refers to bitfields pertaining to either one of the two general-purpose counters. The notation will be used consistently for a single general-purpose counter within each individual programming sequence. G_j will be used for references to the other general-purpose counter.

To summarize, G_i can denote general-purpose counter 0 or general-purpose counter 1 in any programming sequence; if G_i is denoting general-purpose counter 0, then G_j is denoting general-purpose counter 1; if G_i is denoting general-purpose counter 1, then G_j is denoting general-purpose counter 0.

4.6.1.3 Resetting

Use this function to reset the GPCT.

```
Function Gi_Reset_All
{
    Gi_Reset = 1;
    Gi_Mode_Register = 0;
    Gi_Command_Register = 0;
    Gi_Input_Select_Register = 0;
    Gi_Autoincrement_Register = 0;
    Gi_TC_Interrupt_Enable = 0;
    Gi_Gate_Interrupt_Enable = 0;
    Gi_Synchronized_Gate = 1;
    Gi_Gate_Error_Confirm = 1;
    Gi_TC_Error_Confirm = 1;
    Gi_TC_Interrupt_Ack = 1;
    Gi_Gate_Interrupt_Ack = 1;
    Gi_Autoincrement = 0;
}
```

4.6.1.4 Arming

Use the following function to arm the counter after the programming sequence is complete. This function will cause the counter to begin the programmed operation.

```
Function Gi_Arm_All
{
    Gi_Arm = 1;
}
```

4.6.1.5 Simple Event Counting

Simple event counting is an application in which a general-purpose counter counts the edges of its source signal. Progress of counting is observed by monitoring the counter contents, which is achieved by using the software save command and a save register. One variation of this application, called simple gated event counting, allows you to select a gate signal to pause and resume counting.



Note *Simple event counting mimics the behavior of the NI-DAQ functions for the Am9513 counter chip.*

The only possible error condition is rollover. Rollover occurs when the counter attempts to count below 0 (underflow) or above 0xFFFFFFFF hex (overflow). When rollover occurs, the counter continues counting with the wrap-around counter value, which is defined to be 0xFFFFFFFF hex for underflow and 0 for overflow. The rollover condition can be checked, but you can not tell how many rollovers have occurred.

If your application requires counting that exceeds the capabilities of a single general-purpose counter, you may decide to use one general-purpose counter for normal counting, and the other general-purpose counter for counting the first counter TC. Alternatively, you can enable the TC interrupt and use the corresponding interrupt service program to expand the counter width in software. You can use the error-detection mechanism associated with this interrupt to check for any interrupts not being serviced in time; that is, the DAQ-STC will let you know if your system is unable to keep up with the counting.

Use the following function to program a counter for simple event counting. Program the *Gi_Source* to select the signal on which you want to count events. Program the *Gi_Gate* to select the gating signal (for simple gated event counting) or logic low.

```
Function Gi_Simple_Event_Counting
{
    Gi_Load_Source_Select = 0;
    Gi_Load_A = initial counter value;
    Σ
    Gi_Load = 1;
    Σ
    Gi_Source_Select = 0 (G_IN_TIMEBASE1) or 1 through 10 (PFI<0..9>) or
        11 through 17 (RTSI_TRIGGER<0..6>) or 18 (IN_TIMEBASE2)
        or 19 (other G_TC);
    Gi_Source_Polarity = 0 (count rising edges) or 1 (count falling edges);
    Gi_Gate_Select = 1 through 10 (PFI<0..9>) or 11 through 17 (RTSI_TRIGGER<0..6>)
        or 18 (AI START2) or 19 (UI2_TC) or 20 (other G_TC) or
        21 (AI START1) or 31 (logic low);
    Gi_OR_Gate = 0;
    Gi_Output_Polarity = 0 (active high) or 1 (active low);
    Gi_Gate_Select_Load_Source = 0;
```

```

Gi_Gate_Polarity = 0 (disable inversion) or 1 (enable inversion);
Gi_Output_Mode = 1 (one clock cycle output) or 2 (toggle on TC) or 3 (toggle on TC
or gate);
Gi_Loading_On_Gate = 0;
Gi_Loading_On_TC = 0;
Gi_Gating_Mode = 1;
Gi_Gate_On_Both_Edges = 0;
Gi_Trigger_Mode_For_Edge_Gate = 2;
Gi_Stop_Mode = 0;
Gi_Counting_Once = 0;
Gi_Up_Down = 0 (down counting) or 1 (up counting);
Gi_Bank_Switch_Enable = 0;
Gi_Bank_Switch_Mode = 0;
Gi_TC_Interrupt_Enable = 0;
Gi_Gate_Interrupt_Enable = 0;
}

```

4.6.1.6 Buffered Event Counting

Buffered event counting is an application in which a general-purpose counter counts the edges of its source signal. Progress of counting is observed by monitoring the counter contents, at points of interest. This is achieved by using the HW save register and interrupts. We define two modes of operation for this application: noncumulative mode and cumulative mode. In noncumulative mode, the counter is reloaded every time its contents are saved due to the gate action. In cumulative mode, the counter's contents are saved by the gate, but the counter keeps counting.

Noncumulative mode is useful if you are interested in the number of events between two *controlling events*. Cumulative mode is useful if you are interested in monitoring progress in terms of events.

One interesting application is periodic event-count monitoring. For example, you may be interested in the number of events that happened every second. You can do this by programming *Gi* for buffered event counting and *Gj* for pulse generation, and then using the *Gj* output as the *Gi* gate.

Possible error conditions are rollover, gate acknowledge latency error, and stale data error (in noncumulative mode). Rollover is explained in section 4.4.1.1, *Simple Event Counting*. The gate acknowledge latency error occurs if the interrupt service program (ISR) does not manage to read the value in the HW save register before the next hardware save. In noncumulative mode, the stale data error occurs if there are two gate edges without an intervening source edge, indicating that the gate event was too quick to be measured. In cumulative mode, the stale data error is ignored because the gate actions do not affect the counter contents, so that the HW save register always contains the correct value.

Use this function to program a counter for buffered event counting. Program the *Gi_Source* to select the signal on which you want to count events. Program the *Gi_Gate* to select the signal that causes the counter contents to be saved.

```

Function Gi_Buffered_Event_Counting
{
    Gi_Load_Source_Select = 0;
    Gi_Load_A = initial counter value;
    Σ
    Gi_Load = 1;
    Σ
    Gi_Source_Select = 0 (G_IN_TIMEBASE1) or 1 through 10 (PFI<0..9>) or
        11 through 17 (RTSI_TRIGGER<0..6>) or 18 (IN_TIMEBASE2)
        or 19 (other G_TC);
    Gi_Source_Polarity = 0 (count rising edges) or 1 (count falling edges);
    Gi_Gate_Select = 1 through 10 (PFI<0..9>) or 11 through 17
        (RTSI_TRIGGER<0..6>) or 18 (AI START2) or 19 (UI2_TC) or
        20 (other G_TC) or 21 (AI START1) or 31 (logic low);
    Gi_OR_Gate = 0;
    Gi_Output_Polarity = 0 (active low) or 1 (active high);
    Gi_Gate_Select_Load_Source = 0;
    Gi_Gate_Polarity = 0 (disable inversion) or 1 (enable inversion);
    Gi_Output_Mode = 1 (one clock cycle output) or 2 (toggle on TC) or
        3 (toggle on TC or gate);
    Gi_Reload_Source_Switching = 1;
    If (buffered cumulative event counting) then
    {
        Gi>Loading_On_Gate = 0;
    }
    Else
    {
        /*Buffered noncumulative event counting*/
        Gi>Loading_On_Gate = 1;
    }
    Gi>Loading_On_TC = 0;
    Gi>Gating_Mode = 2;
    Gi>Gate_On_Both_Edges = 0;
    Gi>Trigger_Mode_For_Edge_Gate = 3;
    Gi>Stop_Mode = 0;
    Gi>Counting_Once = 0;
    Gi>Up_Down = 0 (down counting) or 1 (up counting) or 2 (controlled by
        G_UP_DOWNi) or 3 (controlled by the internal gate value);
    Gi>Bank_Switch_Enable = 0;
    Gi>Bank_Switch_Mode = 0;
    Gi>TC_Interrupt_Enable = 0;
    Gi>Gate_Interrupt_Enable = 1;
}

```

The gate interrupt notifies the CPU after each counting interval so that the ISR can read the results from the HW save register. In noncumulative mode, the ISR checks for a stale data error, indicating that the gate action was too quick to be measured by the source clock. In this case, the ISR ignores the counter value and writes 0 into the buffer. Once the value from the read is stored in the buffer, the ISR checks for a rollover error and a gate acknowledge latency error.

Use this function as an ISR for buffered event counting.

Function `Event_Counting_ISR`

```

{
Declare variables
    save_1,                /*holds the save register value*/
    g_buffer_done;        /*indicates whether the event counting is complete*/
save_1 = Gi_HW_Save_Register;
If (noncumulative mode) then /*check for stale data in noncumulative mode*/
{
    If (Gi_Stale_Data_St is 1) then
    {
        /*stale data — no source transitions between two relevant gate edges*/
        save_1 = 0;
    }
}
If (g_buffer_done is 0) AND (buffer is not full) then
{
    Write save_1 into the current position in the buffer;
    Increment the pointer to the current position in the buffer;
}
If (all the points have been written into the buffer) then
{
    Gi_Disarm = 1;
    g_buffer_done = 1;
}
Gi_Gate_Interrupt_Ack = 1;
If (Gi_Gate_Error_St is 1) then
{
    /*gate acknowledge latency error — hardware saves are too fast*/
    Inform user that a gate acknowledge latency error has occurred;
    Gi_Gate_Error_Confirm = 1;
}
If (Gi_TC_St is 1) then
{
    /*rollover error — counter value is not correct*/
    Inform user that a rollover error has occurred;
    Gi_TC_Interrupt_Ack = 1;
}
}

```

4.6.1.7 Relative Position Sensing

Relative Position Sensing is an application in which a general-purpose counter counts the edges of its source signal, and the counting direction is controlled by a hardware input or by software.

The only possible error condition is rollover. Rollover occurs when the counter attempts to count below 0 (underflow) or above 0xFFFFFFFF hex (overflow). When rollover occurs, the counter continues counting with the wrap-around counter value, which is defined to be 0xFFFFFFFF hex for underflow and 0 for overflow. The rollover condition can be checked, but you can not tell whether the rollover was caused by underflow or overflow.

Use this function to program a counter for relative position sensing. Program the *Gi_Source* to select the signal on which you want to count events. For relative position sensing controlled by a hardware input, input the hardware up/down control signal on the *G_UP_DOWNi* pin. For relative position sensing controlled by software, set *Gi_Up_Down* = 0 for initial down counting or *Gi_Up_Down* = 1 for initial up counting. After the counter is armed, the count direction can be changed in software by writing to *Gi_Up_Down*.

```
Function Relative_Position_Sensing
{
    Gi_Load_Source_Select = 0;
    Gi_Load_A = initial counter value;
    Σ
    Gi_Load = 1;
    Σ
    Gi_Source_Select = 0 (G_IN_TIMEBASE1) or 1 through 10 (PFI<0..9>) or
        11 through 17 (RTSI_TRIGGER<0..6>) or
        18 (IN_TIMEBASE2) or 19 (other G_TC);
    Gi_Source_Polarity = 0 (count rising edges) or 1 (count falling edges);
    Gi_Gate_Select = 0;
    Gi_OR_Gate = 0;
    Gi_Output_Polarity = 0 (active low) or 1 (active high);
    Gi_Gate_Select_Load_Source = 0;
    Gi_Gate_Polarity = 0 (disable inversion) or 1 (enable inversion);
    Gi_Output_Mode = 1 (one clock cycle output) or 2 (toggle on TC) or
        3 (toggle on TC or gate);
    Gi_Reload_Source_Switching = 1;
    Gi>Loading_On_Gate = 0;
    Gi>Loading_On_TC = 0;
    Gi>Gating_Mode = 2;
    Gi>Gate_On_Both_Edges = 0;
    Gi>Trigger_Mode_For_Edge_Gate = 3;
    Gi>Stop_Mode = 0;
    Gi>Counting_Once = 0;
    If (hardware controlled relative position sensing) then
```

```

{
    Gi_Up_Down = 2;
}
Else
{
    /*Software-controlled relative position sensing*/
    Gi_Up_Down = 0 (down counting) or 1 (up counting);
}
Gi_Bank_Switch_Enable = 0;
Gi_Bank_Switch_Mode = 0;
Gi_TC_Interrupt_Enable = 0;
Gi_Gate_Interrupt_Enable = 0;
}

```

4.6.1.8 Single-Period and Pulsewidth Measurement

Single-period and pulsewidth measurement are applications in which a general-purpose counter counts the edges of its source signal, normally a clock, between successive pairs of gate events. Counter contents are saved at the second of the gate events for later retrieval.



Note *The second of the gate events may also be the first gate event in the next pair.*

Single-period measurement mimics the behavior of the NI-DAQ functions for the Am9513 counter chip.

In single-period measurement, source edges are counted between successive pairs of active gate edges. In single pulsewidth measurement, source edges are counted between the time the gate signal reaches the active level and the time the gate signal reaches the inactive level.

The only possible error condition is rollover. Rollover is explained in section [4.4.1.1, Simple Event Counting](#).

Use this function to program a counter for a single-period measurement or single pulsewidth measurement. Program the *Gi_Source* to select the signal that you want to use as a reference clock. Program the *Gi_Gate* to select the signal on which you want to measure the period or pulsewidth.

```

Function Single_Period_And_Pulse_Width_Measurement
{
    Gi_Load_Source_Select = 0;
    Gi_Load_A = initial counter value;
    Σ
    Gi_Load = 1;
    Σ

```

```

Gi_Source_Select = 0 (G_IN_TIMEBASE1) or 1 through 10 (PFI<0..9>) or
                  11 through 17 (RTSI_TRIGGER<0..6>) or 18 (IN_TIMEBASE2)
                  or 19 (other G_TC);
Gi_Source_Polarity = 0 (count rising edges) or 1 (count falling edges);
Gi_Gate_Select = 1 through 10 (PFI<0..9>) or 11 through 17 (RTSI_TRIGGER<0..6>)
                or 18 (AI START2) or 19 (UI2_TC) or 20 (other G_TC) or
                21 (AI START1) or 31 (logic low);
Gi_OR_Gate = 0;
Gi_Output_Polarity = 0 (active low) or 1 (active high);
Gi_Gate_Select_Load_Source = 0;
Gi_Gate_Polarity = 0 (disable inversion) or 1 (enable inversion);
Gi_Output_Mode = 1 (one clock cycle output) or 2 (toggle on TC) or
                 3 (toggle on TC or gate);
If (single-period measurement) then
{
    Gi_Reload_Source_Switching = 1;
    Gi>Loading_On_Gate = 0;
    Gi>Loading_On_TC = 0;
    Gi>Gating_Mode = 2;
    Gi_Gate_On_Both_Edges = 0;
    Gi_Trigger_Mode_For_Edge_Gate = 0;
    Gi_Stop_Mode = 0;
    Gi_Counting_Once = 2;
    Gi_Up_Down = 1;
}
Else
{
    /*Single pulsewidth measurement*/
    Gi_Reload_Source_Switching = 0;
    Gi>Loading_On_Gate = 1;
    Gi>Loading_On_TC = 0;
    Gi>Gating_Mode = 1;
    Gi_Gate_On_Both_Edges = 0;
    Gi_Trigger_Mode_For_Edge_Gate = 2;
    Gi_Stop_Mode = 0;
    Gi_Counting_Once = 2;
    Gi_Up_Down = 1;
}
Gi_Bank_Switch_Enable = 0;
Gi_Bank_Switch_Mode = 0;
Gi_TC_Interrupt_Enable = 0;
Gi_Gate_Interrupt_Enable = 0;
}

```

4.6.1.9 Buffered Period, Semiperiod, and Pulsewidth Measurement

Buffered period measurement, buffered semiperiod measurement, and buffered pulsewidth measurement are applications in which a general-purpose counter counts the edges of its source signal, normally a clock, over multiple counting intervals. Progress of counting is observed by monitoring the counter contents at points of interest, that is, on a specified gate event. This is achieved by using the HW save register and interrupts.

In buffered period measurement, source edges are counted between successive pairs of active gate edges. In buffered semiperiod measurement, source edges are counted between each gate transition. In buffered pulsewidth measurement, source edges are counted between the time the gate signal reaches the active level and the time the gate signal reaches the inactive level.

Possible error conditions are rollover, gate acknowledge latency error, and stale data error. Rollover is explained in section 4.4.1.1, *Simple Event Counting*. The gate acknowledge latency and stale data errors are explained in section 4.6.1.6, *Buffered Event Counting*.

Use this function to program a counter for a buffered period measurement, buffered semiperiod measurement, or buffered pulsewidth measurement. Program the *Gi_Source* to select the signal that you want to use as a reference clock. Program the *Gi_Gate* to select the signal on which you want to measure the period, semiperiod, or pulsewidth.

```
Function Buffered_Period_And_Semi_Period_And_Pulse_Width_Measurement
{
  Gi_Load_Source_Select = 0;
  Gi_Load_A = initial counter value;
  Σ
  Gi_Load = 1;
  Σ
  Gi_Source_Select = 0 (G_IN_TIMEBASE1) or 1 through 10 (PFI<0..9>) or
                    11 through 17 (RTSI_TRIGGER<0..6>) or 18 (IN_TIMEBASE2)
                    or 19 (other G_TC);
  Gi_Source_Polarity = 0 (count rising edges) or 1 (count falling edges);
  Gi_Gate_Select = 1 through 10 (PFI<0..9>) or 11 through 17 (RTSI_TRIGGER<0..6>)
                 or 18 (AI START2) or 19 (UI2_TC) or 20 (other G_TC) or
                 21 (AI START1) or 31 (Logic low);
  Gi_OR_Gate = 0;
  Gi_Output_Polarity = 0 (active low) or 1 (active high);
  Gi_Gate_Select_Load_Source = 0;
  Gi_Gate_Polarity = 0 (disable inversion) or 1 (enable inversion);
  Gi_Output_Mode = 1 (one clock cycle output) or 2 (toggle on TC) or
                  3 (toggle on TC or gate);
  Gi_Reload_Source_Switching = 0;
  Gi>Loading_On_Gate = 1;
  Gi>Loading_On_TC = 0;
```

```

If (buffered period measurement) then
{
    Gi_Gating_Mode = 2;
    Gi_Gate_On_Both_Edges = 0;
}
Else if (buffered semiperiod measurement) then
{
    Gi_Gating_Mode = 3;
    Gi_Gate_On_Both_Edges = 1;
}
Else
{
    /*Buffered pulsewidth measurement*/
    Gi_Gating_Mode = 1;
    Gi_Gate_On_Both_Edges = 0;
}

Gi_Trigger_Mode_For_Edge_Gate = 3;
Gi_Stop_Mode = 0;
Gi_Counting_Once = 0;
Gi_Up_Down = 1;
Gi_Bank_Switch_Enable = 0;
Gi_Bank_Switch_Mode = 0;
Gi_TC_Interrupt_Enable = 0;
Gi_Gate_Interrupt_Enable = 1;
}

```

The gate interrupt notifies the CPU after each counting interval so that the ISR can read the results from the HW save register. The ISR first checks for a stale data error, indicating that the gate action was too quick to be measured by the source clock. In this case, the ISR ignores the counter value and writes 0 into the buffer. The ISR then checks for a rollover error and a gate acknowledge latency error.

Use this function as an ISR for buffered period, semiperiod, and pulsewidth measurement.

```

Function Period_And_Semi_Period_And_Pulse_Width_Measurement_ISR
{
    Declare variables
    save_1, /*holds the save register value*/
    g_buffer_done; /*indicates whether the measurement is complete*/
    save_1 = Gi_HW_Save_Register;
    If (Gi_Stale_Data_St is 1) then
    {
        /*stale data — no source transitions between two relevant gate edges*/
        save_1 = 0;
    }
    If (g_buffer_done is 0) AND (buffer is not full) then

```

```

    {
        Write save_1 into the current position in the buffer;
        Increment the pointer to the current position in the buffer;
    }
    If (all the points have been written into the buffer) then
    {
        Gi_Disarm = 1;
        g_buffer_done = 1;
    }
    Gi_Gate_Interrupt_Ack = 1;
    If (Gi_Gate_Error_St is 1) then
    {
        /*gate acknowledge latency error — hardware saves are too fast*/
        Inform user that a gate acknowledge latency error has occurred;
        Gi_Gate_Error_Confirm = 1;
    }
    If (Gi_TC_St is 1) then
    {
        /*rollover error — counter value is not correct*/
        Inform user that a rollover has occurred;
        Gi_TC_Interrupt_Ack = 1;
    }
}

```

4.6.1.10 Pulse and Continuous Pulse-Train Generation

In pulse generation a counter generates a single pulse of specified duration and specified delay. In continuous pulse-train generation, a counter generates a rectangular waveform of specified frequency and duty cycle.

Three modes of operation are defined for pulse generation: single-pulse generation, single-triggered pulse generation, and retriggerable single-pulse generation. In single-pulse generation, the pulse is generated based on the software arm signal. In single-triggered pulse generation, the pulse is generated based on a hardware trigger. In retriggerable single pulse generation, a pulse is generated on each hardware trigger active edge. A fourth mode of operation, buffered retriggerable single pulse generation, is defined for the hardware but is not supported in this programming section.



Note *Pulse and continuous pulse-train generation mimic the behavior of the NI DAQ functions for the Am9513 counter chip.*

No errors are detected in these applications. Use this function to program a counter for single pulse generation, single-triggered pulse generation, or retriggerable single pulse generation. Program the *Gi_Source* to select the signal that you want to use as a reference clock. For single-triggered pulse generation and retriggerable single pulse generation, program *Gi_Gate* to select the signal that you want to use as a hardware trigger.

```

Function Single_Pulse_Generation
{
    Gi_Load_Source_Select = 0;
    If (single pulse generation) then
    {
        Gi_Load_A = delay from software arm to first edge of pulse - 1;
    }
    Else
    {
        /*Single-triggered pulse generation or retriggerable single pulse generation*/
        Gi_Load_A = delay from hardware trigger to first edge of pulse - 1;
    }
    Σ
    Gi_Load = 1;
    Σ
    Gi_Load_B = pulsewidth - 1;
    Gi_Load_Source_Select = 1;
    Gi_Source_Select = 0 (G_IN_TIMEBASE1) or 1 through 10 (PFI<0..9>) or
        11 through 17 (RTSI_TRIGGER<0..6>) or 18 (IN_TIMEBASE2)
        or 19 (other G_TC);
    Gi_Source_Polarity = 0 (count rising edges) or 1 (count falling edges);
    Gi_Gate_Select = 1 through 10 (PFI<0..9>) or 11 through 17 (RTSI_TRIGGER<0..6>)
        or 18 (AI START2) or 19 (UI2_TC) or 20 (other G_TC) or
        21 (AI START1) or 31 (logic low);

    Gi_OR_Gate = 0;
    Gi_Output_Polarity = 0 (active low) or 1 (active high);
    Gi_Gate_Select_Load_Source = 0;
    Gi_Gate_Polarity = 0 (disable inversion) or 1 (enable inversion);
    Gi_Output_Mode = 1 (one clock cycle output) or 2 (toggle on TC) or
        3 (toggle on TC or gate);

    Gi_Reload_Source_Switching = 1;
    Gi>Loading_On_Gate = 0;
    Gi>Loading_On_TC = 1;
    If (single pulse generation) then
    {
        Gi_Gating_Mode = 0;
    }
    Else
    {
        /*Single-triggered pulse generation or retriggerable single pulse generation*/
        Gi_Gating_Mode = 2;
    }

    Gi_Gate_On_Both_Edges = 0;
    Gi_Trigger_Mode_For_Edge_Gate = 2;
    Gi_Stop_Mode = 2;
    If (retriggerable single pulse generation) then

```

```

    {
        Gi_Counting_Once = 0;
    }
    Else
    {
        /*Single pulse generation or single-triggered pulse generation*/
        Gi_Counting_Once = 1;
    }
    Gi_Up_Down = 0;
    Gi_Bank_Switch_Enable = 0;
    Gi_Bank_Switch_Mode = 0;
    Gi_TC_Interrupt_Enable = 0;
    Gi_Gate_Interrupt_Enable = 0;
}

```

Use this function to program a counter for continuous pulse-train generation. Program the *Gi_Source* to select the signal that you want to use as a reference clock. Program the *Gi_Gate* to select the signal that you want to use as a hardware trigger.

Function *Continuous_Pulse_Train_Generation*

```

{
    Gi_Load_Source_Select = 0;
    Gi_Load_A = delay from hardware trigger to first edge of pulse - 1;
    Σ
    Gi_Load = 1;
    Σ
    Gi_Load_A = pulse interval - 1;
    Gi_Load_B = pulsewidth - 1;
    Gi_Load_Source_Select = 1;
    Gi_Source_Select = 0 (G_IN_TIMEBASE1) or 1 through 10 (PFI<0..9>) or
        11 through 17 (RTSI_TRIGGER<0..6>) or 18 (IN_TIMEBASE2)
        or 19 (other G_TC);
    Gi_Source_Polarity = 0 (count rising edges) or 1 (count falling edges);
    Gi_Gate_Select = 1 through 10 (PFI(0:9)) or 11 through 17 (RTSI_TRIGGER<0..6>) or
        18 (AI START2) or 19 (UI2_TC) or 20 (other G_TC) or
        21 (AI START1) or 31 (logic low);
    Gi_OR_Gate = 0;
    Gi_Output_Polarity = 0 (active low) or 1 (active high);
    Gi_Gate_Select_Load_Source = 0;
    Gi_Gate_Polarity = 0 (disable inversion) or 1 (enable inversion);
    Gi_Output_Mode = 1 (one clock cycle output) or 2 (toggle on TC) or
        3 (toggle on TC or gate);
    Gi_Reload_Source_Switching = 1;
    Gi>Loading_On_Gate = 0;
    Gi>Loading_On_TC = 1;
    Gi_Gating_Mode = 2;
    Gi_Gate_On_Both_Edges = 0;
    Gi_Trigger_Mode_For_Edge_Gate = 2;
}

```

```

    Gi_Stop_Mode = 0;
    Gi_Counting_Once = 0;
    Gi_Up_Down = 0;
    Gi_Bank_Switch_Enable = 0 (disable bank switching) or 1 (enable bank switching);
    Gi_Bank_Switch_Mode = 0;
    Gi_TC_Interrupt_Enable = 0;
    Gi_Gate_Interrupt_Enable = 0;
}

```

If you set `Gi_Bank_Switch_Enable` to 1 in the function `Continuous_Pulse_Train_Generation`, you can use this function to change the pulse-generation rate while the pulse-train is in progress. The variable `g_bank_to_be_used` indicates the bank to be used and should be initialized to 0.

```

Function Gi_Seamless_Pulse_Train_Change
{
    /*See if you can legally change the rate. You cannot change the rate twice in a row before
    generation of at least one cycle of intermediate frequency*/
    If (Gi_Bank_St equals g_bank_to_be_used) then
    {
        Gi_Load_A = pulse interval - 1;
        Gi_Load_B = pulsewidth - 1;
        Gi_Bank_Switch_Start = 1;
        If (g_bank_to_be_used is 0) then
            g_bank_to_be_used = 1;
        Else
            g_bank_to_be_used = 0;
    }
    Else
    {
        Inform user that pulse-generation rate cannot be changed;
    }
}

```

Two pulse-train generation modes are defined for the hardware but are not supported in this programming section. These are buffered static pulse-train generation and buffered pulse-train generation.

4.6.1.11 Frequency Shift Keying

FSK is an application in which a counter is used to generate a rectangular wave whose frequency is controlled by a hardware input. An example is generation of a 300 kHz square wave when the controlling signal has a low logic value and a 500 kHz square wave when the controlling signal has a high logic value. No errors are detected in this application.

Use this function to program a counter for FSK. Program the *Gi_Source* to select the signal that you want to use as a reference clock. Program the *Gi_Gate* to select the signal that is to be used as a hardware input to control the frequency.

Function `Frequency_Shift_Keying`

```
{
    Gi_Load_Source_Select = 0;
    Gi_Load_A = delay from software arm to first edge of pulse - 1;
    Σ
    Gi_Load = 1;
    Σ
    Gi_Load_A = pulse interval for inactive gate - 1;
    Gi_Load_B = pulsewidth for inactive gate - 1;
    Gi_Load_Source_Select = 1;
    Gi_Bank_Switch_Enable = 1;
    Gi_Load_A = pulse interval for active gate - 1;
    Gi_Load_B = pulsewidth for active gate - 1;
    Gi_Source_Select = 0 (G_IN_TIMEBASE1) or 1 through 10 (PFI<0..9>) or
        11 through 17 (RTSI_TRIGGER<0..6>) or 18 (IN_TIMEBASE2)
        or 19 (other G_TC);
    Gi_Source_Polarity = 0 (count rising edges) or 1 (count falling edges);
    Gi_Gate_Select = 1 through 10 (PFI<0..9>) or 11 through 17 (RTSI_TRIGGER<0..6>)
        or 18 (AI START2) or 19 (UI2_TC) or 20 (other G_TC) or
        21 (AI START1) or 31 (logic low);
    Gi_OR_Gate = 0;
    Gi_Output_Polarity = 0 (active low) or 1 (active high);
    Gi_Gate_Select_Load_Source = 1;
    Gi_Gate_Polarity = 0 (disable inversion) or 1 (enable inversion);
    Gi_Output_Mode = 1 (one clock cycle output) or 2 (toggle on TC) or
        3 (toggle on TC or gate);
    Gi_Reload_Source_Switching = 1;
    Gi>Loading_On_Gate = 0;
    Gi>Loading_On_TC = 1;
    Gi>Gating_Mode = 1;
    Gi_Gate_On_Both_Edges = 0;
    Gi_Trigger_Mode_For_Edge_Gate = 3;
    Gi_Stop_Mode = 0;
    Gi_Counting_Once = 0;
    Gi_Up_Down = 0;
    Gi_Bank_Switch_Enable = 1;
    Gi_Bank_Switch_Mode = 0;
    Gi_TC_Interrupt_Enable = 0;
    Gi_Gate_Interrupt_Enable = 0;
}
```

4.6.1.12 Pulse-Train Generation for ETS

ETS is a data acquisition operation in which data on a repetitive waveform with a frequency higher than the Nyquist frequency of the system is obtained by sampling the waveform at instants skewed in relation to the beginning of each wave pulse. The DAQ-STC general-purpose counters can be used to generate timing for ETS.

No errors are detected in these applications. Since the period incrementing circuitry in the DAQ-STC is an adder with no overflow detection, you will not be notified if overflow occurs.

Use this function to program a counter for pulse-train generation for ETS. Program the *Gi_Source* to select the signal that you want to use as a reference clock. Program the *Gi_Gate* to select the trigger signal that initiates each pulse.

Function `Pulse_Train_Generation_For_ETS`

```
{
    Gi_Autoincrement = increment value for delay from trigger;
    Gi_Load_Source_Select = 0;
    Gi_Load_A = delay from software arm to first edge of pulse - 1;
    Σ
    Gi_Load = 1;
    Σ
    Gi_Load_B = pulsewidth - 1;
    Gi_Load_Source_Select = 1;
    Gi_Source_Select = 0 (G_IN_TIMEBASE1) or 1 through 10 (PFI<0..9>) or
                        11 through 17 (RTSI_TRIGGER<0..6>) or 18 (IN_TIMEBASE2)
                        or 19 (other G_TC);
    Gi_Source_Polarity = 0 (count rising edges) or 1 (count falling edges);
    Gi_Gate_Select = 1 through 10 (PFI<0..9>) or 11 through 17 (RTSI_TRIGGER<0..6>)
                    or 18 (AI START2) or 19 (UI2_TC) or 20 (other G_TC) or
                    21 (AI START1) or 31 (logic low);
    Gi_OR_Gate = 0;
    Gi_Output_Polarity = 0 (active low) or 1 (active high);
    Gi_Gate_Select_Load_Source = 0;
    Gi_Gate_Polarity = 0 (disable inversion) or 1 (enable inversion);
    Gi_Output_Mode = 1 (one clock cycle output) or 2 (toggle on TC) or
                    3 (toggle on TC or gate);
    Gi_Reload_Source_Switching = 1;
    Gi>Loading_On_Gate = 0;
    Gi>Loading_On_TC = 1;
    Gi_Gating_Mode = 2;
    Gi_Gate_On_Both_Edges = 0;
    Gi_Trigger_Mode_For_Edge_Gate = 2;
    Gi_Stop_Mode = 2;
    Gi_Counting_Once = 0;
    Gi_Up_Down = 0;
    Gi_Bank_Switch_Enable = 0;
```



```

    Gi_Bank_Switch_Mode = 0;
    Gi_TC_Interrupt_Enable = 0;
    Gi_Gate_Interrupt_Enable = 0;
}

```

4.6.1.13 Reading the Counter Contents

In several functions (for example, simple event counting and relative position sensing) you may want to read the counter contents while the counter is armed and counting. The save register allows you to access the counter contents without disturbing the counting process.

Use this function to read the counter contents while the counter is armed and counting. The function reads the save register value several times in case a read occurs while the save register is being updated.

Function `Gi_Watch`

```

{
    Declare variables
    save_1,                               /*first read*/
    save_2;                               /*second read*/
    Gi_Save_Trace = 0;
    Σ
    Gi_Save_Trace = 1;
    /*Read two times*/
    save_1 = Gi_Save_Registers;
    save_2 = Gi_Save_Registers;
    /*If the two values read are not equal, read once more*/
    If (save_1 does not equal save_2) then
    {
        save_1 = Gi_Save_Registers;
    }
    Inform user of the counter contents contained in save_1;
}

```

4.6.1.14 Reading the Hardware Save Registers

In pulse width and period measurement applications, you need to read the value in the hardware save registers. The `Gi_Gate_Interrupt_St` bit will be set whenever a value is saved in the `Gi_HW_Save_Registers`. This status bit indicates when it is time to read the hardware save registers.

```

Function Read_Gi_HW_Save_Registers
{
    Declare variables
    save=0;
    /*Read from the AI_Status_1_Register to check the G0_Gate_Interrupt_St or
    read from the AO_Status_1_Register to check the G1_Gate_Interrupt_St.
    If the status bit is set, read the hardware save registers (24 bit value). */

    if (Gi_Gate_Interrupt_St)
        save = Gi_HW_Save_Registers;
}

```

4.6.1.15 Enabling the General Purpose Counter/Timer Output Pin

The output pin for each general purpose counter/timer must be enabled before it can be used. This is required for applications such as single or continuous pulse generation.

```

Function Enable_Gi_Out
{
    GPFO_i_Output_Enable=1;
    GPFO_i_Output_Select=0;
}

```

4.6.2 Bitfield Descriptions

Bits in the register bit maps are organized into bitfields. A bitfield can contain one or more bits. Only bits with contiguous locations within a register can belong to a bitfield. The high and low pairs of load and save registers for 24-bit counters are also treated as bitfields. The GPCT-related bitfields are described below. Not all bitfields referred to in section 4.6, *Programming Information*, are listed here. To locate a particular bitfield description within this manual, refer to Appendix B, *Register Information*.

Gi_Analog_Trigger_Reset

$i = 0$	bit: 3	type: Strobe	in: G0_Command_Register	address: 6
$i = 1$	bit: 3	type: Strobe	in: G1_Command_Register	address: 7

This bit clears the hysteresis registers in the analog trigger circuit. Set this bit to 1 at the time you arm general-purpose counter i if you want to use analog triggering in hysteresis mode for any general-purpose counter i input signal. Before setting this bit to 1, make sure that the analog trigger is not being used by any other part of the DAQ-STC. You should not set this bit to 1 in any other case. This bit is cleared automatically.

Gi_Arm

<i>i</i> = 0	bit: 0	type: Strobe	in: G0_Command_Register	address: 6
<i>i</i> = 1	bit: 0	type: Strobe	in: G1_Command_Register	address: 7

Setting this bit to 1 arms general-purpose counter *i*. The counter remains armed (and the bit remains set) until it is disarmed, either by hardware or by setting *Gi_Disarm* to 1. Related bitfields: *Gi_Disarm*.

Gi_Arm_Copy

<i>i</i> = 0	bit: 13	type: Strobe	in: G1_Command_Register	address: 7
<i>i</i> = 1	bit: 13	type: Strobe	in: G0_Command_Register	address: 6

Setting this bit to 1 arms general purpose counter *i*. The counter remains armed (and the bit remains set) until it is disarmed, either by hardware or by setting *Gi_Disarm* to 1. Related bitfields: *Gi_Disarm*.

Gi_Armed_St

<i>i</i> = 0	bit: 8	type: Read	in: G_Status_Register	address: 4
<i>i</i> = 1	bit: 9	type: Read	in: G_Status_Register	address: 4

This bit indicates whether general-purpose counter *i* is armed:

- 0: Not armed.
- 1: Armed.

Related bitfields: *Gi_Arm*, *Gi_Arm_Copy*.

Gi_Autoincrement

<i>i</i> = 0	bits: <0..7>	type: Write	in: G0_Autoincrement_Register	address: 68
<i>i</i> = 1	bits: <0..7>	type: Write	in: G1_Autoincrement_Register	address: 69

This 8-bit register holds a fixed value that is added to the contents of load register A after each counter reload, so that on the next reload the counter will load the incremented value.

You should use the autoincrement feature in pulse-train generation for ETS to automatically increase the pulse delay after each trigger.

Gi_Bank_St

<i>i</i> = 0	bit: 0	type: Read	in: Joint_Status_1_Register	address: 27
<i>i</i> = 1	bit: 1	type: Read	in: Joint_Status_1_Register	address: 27

This bit indicates the load register bank used by general-purpose counter *i*:

- 0: Bank X.
- 1: Bank Y.

***Gi*_Bank_Switch_Enable**

<i>i</i> = 0	bit: 12	type: Write	in: G0_Command_Register	address: 6
<i>i</i> = 1	bit: 12	type: Write	in: G1_Command_Register	address: 7

If the general-purpose counter *i* is not armed, this bit selects the bank to which you can write:

- 0: Bank X.
- 1: Bank Y.

If the general-purpose counter *i* is armed, this bit enables bank switching:

- 0: Disabled.
- 1: Enabled.

***Gi*_Bank_Switch_Mode**

<i>i</i> = 0	bit: 11	type: Write	in: G0_Command_Register	address: 6
<i>i</i> = 1	bit: 11	type: Write	in: G1_Command_Register	address: 7

This bit selects the source that controls general purpose counter *i* load register bank switching, if bank switching is enabled:

- 0: Gate.
- 1: Software.

Related bitfields: *Gi*_Bank_Switch_Enable, *Gi*_Bank_Switch_Start.

***Gi*_Bank_Switch_Start**

<i>i</i> = 0	bit: 10	type: Strobe	in: G0_Command_Register	address: 6
<i>i</i> = 1	bit: 10	type: Strobe	in: G1_Command_Register	address: 7

Setting this bit to 1 indicates load register bank switching on the condition selected by *Gi*_Bank_Switch_Mode.

You will typically use this bit in an interrupt service program. This bit is cleared automatically. Related bitfields: *Gi*_Bank_Switch_Start.

***Gi*_Counting_Once**

<i>i</i> = 0	bits: <10..11>	type: Write	in: G0_Mode_Register	address: 26
<i>i</i> = 1	bits: <10..11>	type: Write	in: G1_Mode_Register	address: 27

This bit determines whether the hardware disarms the counter when the counter stops due to a hardware condition:

- 0: No hardware disarm.
- 1: Disarm at the TC that stops counting.
- 2: Disarm at the G_GATE that stops counting.
- 3: Disarm at the TC or G_GATE that stops counting, whichever comes first.

***Gi*_Counting_St**

<i>i</i> = 0	bit: 2	type: Read	in: G_Status_Register	address: 4
<i>i</i> = 1	bit: 3	type: Read	in: G_Status_Register	address: 4

If general-purpose counter *i* is armed, this bit indicates whether the counter is counting:

- 0: No.
- 1: Yes.

If the counter is not armed, this bit should be ignored. Related bitfields: *Gi*_Armed_St.

***Gi*_Disarm**

<i>i</i> = 0	bit: 4	type: Strobe	in: G0_Command_Register	address: 6
<i>i</i> = 1	bit: 4	type: Strobe	in: G1_Command_Register	address: 7

Setting this bit to 1 disarms general-purpose counter *i*. This bit is cleared automatically.

***Gi*_Disarm_Copy**

<i>i</i> = 0	bit: 15	type: Strobe	in: G1_Command_Register	address: 7
<i>i</i> = 1	bit: 15	type: Strobe	in: G0_Command_Register	address: 6

Setting this bit to 1 disarms general-purpose counter *i*. This bit is cleared automatically.

***Gi*_Gate_Error_Confirm**

<i>i</i> = 0	bit: 5	type: Strobe	in: Interrupt_A_Ack_Register	address: 2
<i>i</i> = 1	bit: 1	type: Strobe	in: Interrupt_B_Ack_Register	address: 3

Setting this bit to 1 clears *Gi*_Gate_Error_St. This bit is cleared automatically. Related bitfields: *Gi*_Gate_Error_St.

***Gi*_Gate_Error_St**

<i>i</i> = 0	bit: 14	type: Read	in: G_Status_Register	address: 4
<i>i</i> = 1	bit: 15	type: Read	in: G_Status_Register	address: 4

This bit indicates the detection of a general-purpose counter *i* gate acknowledge latency error:

- 0: No.
- 1: Yes.

To clear this bit, set *Gi*_Gate_Error_Confirm to 1. Related bitfields: *Gi*_Gate_Error_Confirm.

***Gi*_Gate_Interrupt_Ack**

<i>i</i> = 0	bit: 15	type: Strobe	in: Interrupt_A_Ack_Register	address: 2
<i>i</i> = 1	bit: 15	type: Strobe	in: Interrupt_B_Ack_Register	address: 3

Setting this bit to 1 clears *Gi*_Gate_Interrupt_St and acknowledges the gate interrupt request (in either interrupt bank) if the gate interrupt is enabled. This bit is cleared automatically.

Related bitfields: *Gi*_Gate_Interrupt_St.

***Gi*_Gate_Interrupt_Enable**

<i>i</i> = 0	bit: 8	type: Write	in: Interrupt_A_Enable_Register	address: 73
<i>i</i> = 1	bit: 10	type: Write	in: Interrupt_B_Enable_Register	address: 75

This bit enables the gate interrupt:

- 0: Disabled.
- 1: Enabled.

The relevant gate edge is:

- Stop edge in case of level gating.
- Active edge (both start and stop) in case of edge gating.

Related bitfields: *Gi*_Gating_Mode, *Gi*_Gate_On_Both_Edges.

***Gi*_Gate_Interrupt_St**

<i>i</i> = 0	bit: 2	type: Read	in: AI_Status_1_Register	address: 2
<i>i</i> = 1	bit: 2	type: Read	in: AO_Status_1_Register	address: 3

This bit indicates whether a gate interrupt has occurred in general-purpose counter *i*:

- 0: No interrupt.
- 1: Interrupt request generated.

This bit can be cleared by setting *Gi*_Gate_Interrupt_Ack to 1. Related bitfields: *Gi*_Gate_Interrupt_Ack. Refer to Table 8-2, *Interrupt Condition Summary*, for more information.

***Gi*_Gate_On_Both_Edges**

<i>i</i> = 0	bit: 2	type: Write	in: G0_Mode_Register	address: 26
<i>i</i> = 1	bit: 2	type: Write	in: G1_Mode_Register	address: 27

This bit enables you to use both gate edges to generate the gate interrupt and/or to control counter operation:

- 0: Disabled.
- 1: Enabled.

This bit also affects where interrupts are generated.

Gi_Gate_Polarity

<i>i</i> = 0	bit: 13	type: Write	in: G0_Mode_Register	address: 26
<i>i</i> = 1	bit: 13	type: Write	in: G1_Mode_Register	address: 27

This bit selects the polarity of the G_GATE input signal:

- 0: Active high.
- 1: Active low.

Gi_Gate_Second_Irq_Enable

<i>i</i> = 0	bit: 8	type: Write	in: Second_Irq_A_Enable_Register	address: 74
<i>i</i> = 1	bit: 10	type: Write	in: Second_Irq_B_Enable_Register	address: 76

This bit enables the gate interrupt in the secondary interrupt bank:

- 0: Disabled.
- 1: Enabled.

The relevant gate edge is:

- Stop edge in case of level gating.
- Active edge (both start and stop) in case of edge gating.

Related bitfields: *Gi_Gating_Mode*, *Gi_Gate_On_Both_Edges*.

Gi_Gate_Select

<i>i</i> = 0	bits: <7..11>	type: Write	in: G0_Input_Select_Register	address: 36
<i>i</i> = 1	bits: <7..11>	type: Write	in: G1_Input_Select_Register	address: 37

This bitfield selects the G_GATE source for general-purpose counter *i*:

- 1-10: PFI<0..9>.
- 11-17: RTSI_TRIGGER<0..6>.
- 18: The internal analog input signal START2.
- 19: The internal analog output signal UI2_TC. See AO_UPDATE2_Output_Toggle.
- 20: The G_TC signal from the other general-purpose counter.
- 21: The internal analog input signal START1.
- 31: Logic low.

Related bitfields: AO_UPDATE2_Output_Toggle.

***Gi*_Gate_Select_Load_Source**

<i>i</i> = 0	bit: 12	type: Write	in: G0_Input_Select_Register	address: 36
<i>i</i> = 1	bit: 12	type: Write	in: G1_Input_Select_Register	address: 37

This bit enables the selection of the load register by the counter gate:

- 0: Disabled.
- 1: Enabled.

When this bit is set to 1, an active gate level selects load register A, and an inactive gate level selects load register B. Also, *Gi*_Reload_Source_Switching is ignored. This feature can be used only in conjunction with level gating. Related bitfields: *Gi*_Gating_Mode, *Gi*_Reload_Source_Switching.

***Gi*_Gate_St**

<i>i</i> = 0	bit: 2	type: Read	in: Joint_Status_1_Register	address: 27
<i>i</i> = 1	bit: 3	type: Read	in: Joint_Status_1_Register	address: 27

This bit indicates status of the general-purpose counter gate:

- 0: Inactive gate.
- 1: Active gate.

This bit can only be used in the level-gating mode. Note that active gate does not always mean high logic. Related bitfields: *Gi*_Gating_Mode, *Gi*_Gate_Polarity.

***Gi*_Gating_Mode**

<i>i</i> = 0	bits: <0..1>	type: Write	in: G0_Mode_Register	address: 26
<i>i</i> = 1	bits: <0..1>	type: Write	in: G1_Mode_Register	address: 27

This bit enables and selects the counter gating mode:

- 0: Gating is disabled.
- 1: Level gating.
- 2: Edge gating:
 - Rising edge if *Gi*_Gating_Polarity is set to 0.
 - Falling edge if *Gi*_Gating_Polarity is set to 1.
- 3: Edge gating:
 - Falling edge if *Gi*_Gating_Polarity is set to 0.
 - Rising edge if *Gi*_Gating_Polarity is set to 1.

When *Gi*_Gating_Mode is 0 (gating disabled), gate level is available only for control of counting direction (up/down), and for no other purpose. Related bitfields: *Gi*_Gating_Polarity.

Gi_HW_Save_St

<i>i</i> = 0	bit: 12	type: Read	in: Joint_Status_2_Register	address: 29
<i>i</i> = 1	bit: 13	type: Read	in: Joint_Status_2_Register	address: 29

This bit indicates the status of the HW save register for general-purpose counter *i*:

- 0: HW save register is tracing the counter.
- 1: HW save register is latched for later read.

Related bitfields: *Gi_Save_Trace*.

Gi_HW_Save_Value

<i>i</i> = 0	bits: <0..7>	type: Read	in: G0_HW_Save_Registers	address: 8
	bits: <0..15>	type: Read	in: G0_HW_Save_Registers	address: 9
<i>i</i> = 1	bits: <0..7>	type: Read	in: G1_HW_Save_Registers	address: 10
	bits: <0..15>	type: Read	in: G1_HW_Save_Registers	address: 11

This bitfield latches the contents of general-purpose counter *i* on the G_GATE edge appropriate for the selected gating mode. Refer to *Gi_Gating_Mode* for a discussion of gating modes. The eight MSBs are located at the lower address and the 16 LSBs are located at the higher address. Related bitfields: *Gi_Gating_Mode*.

Gi_Little_Big_Endian

<i>i</i> = 0	bit: 9	type: Write	in: G0_Command_Register	address: 6
<i>i</i> = 1	bit: 9	type: Write	in: G1_Command_Register	address: 7

This bit selects the load or save register segment to be used for automatic interrupt acknowledgment:

- 0: Low register.
- 1: High register.

Related bitfields: *Gi_Read_Acknowledges_Irq*, *Gi_Write_Acknowledges_Irq*.

Gi_Load

<i>i</i> = 0	bit: 2	type: Strobe	in: G0_Command_Register	address: 6
<i>i</i> = 1	bit: 2	type: Strobe	in: G1_Command_Register	address: 7

Setting this bit to 1 loads the contents of the selected load register into general-purpose counter *i*. This bit is cleared automatically. Related bitfields: *Gi_Load_Source_Select*.

Gi_Load_A

<i>i</i> = 0	bits: <0..7>	type: Write	in: G0_Load_A_Registers	address: 28
	bits: <0..15>	type: Write	in: G0_Load_A_Registers	address: 29
<i>i</i> = 1	bits: <0..7>	type: Write	in: G1_Load_A_Registers	address: 32
	bits: <0..15>	type: Write	in: G1_Load_A_Registers	address: 33

This bitfield is load register A for general-purpose counter *i*. If load register A is the selected load register, the counter loads the value contained in this bitfield on *Gi_Load*, on the counter TC, and on the G_GATE induced counter reload condition (if G_GATE reloading is enabled). The eight MSBs are located at the lower address and the 16 LSBs are located at the higher address. Related Bitfields: *Gi_Next_Load_Source_St*, *Gi_Load*, *Gi_Loading_On_Gate*.

Gi_Load_B

<i>i</i> = 0	bits: <0..7>	type: Write	in: G0_Load_B_Registers	address: 30
	bits: <0..15>	type: Write	in: G0_Load_B_Registers	address: 31
<i>i</i> = 1	bits: <0..7>	type: Write	in: G1_Load_B_Registers	address: 34
	bits: <0..15>	type: Write	in: G1_Load_B_Registers	address: 35

This bitfield is load register B for general-purpose counter *i*. If load register B is the selected load register, the counter loads the value contained in this bitfield on *Gi_Load*, on the counter TC, and on the G_GATE induced counter reload condition (if G_GATE reloading is enabled). The eight MSBs are located at the lower address and the 16 LSBs are located at the higher address. Related Bitfields: *Gi_Next_Load_Source_St*, *Gi_Load*, *Gi_Loading_On_Gate*.

Gi_Load_Source_Select

<i>i</i> = 0	bit: 7	type: Write	in: G0_Mode_Register	address: 26
<i>i</i> = 1	bit: 7	type: Write	in: G1_Mode_Register	address: 27

If general-purpose counter *i* is disarmed, this bit selects the initial counter load register:

- 0: Load register A.
- 1: Load register B.

The source for subsequent loads depends on *Gi_Reload_Source_Switching*. If general-purpose counter *i* is armed, writing to this bit has no effect. Related bitfields: *Gi_Reload_Source_Switching*, *Gi_Arm*, *Gi_Arm_Copy*.

***Gi*_Loading_On_Gate**

<i>i</i> = 0	bit: 14	type: Write	in: G0_Mode_Register	address: 26
<i>i</i> = 1	bit: 14	type: Write	in: G1_Mode_Register	address: 27

This bit determines whether the gate signal causes counter reload:

- 0: Gate signal does not cause counter reload.
- 1: Counter is reloaded on gate edge that stops the counter, unless edge gating is used and *Gi_Trigger_Mode_For_Edge_Gate* is set to 3. In the later case, counter is reloaded on every selected gate edge.

Reloading occurs on active source edge. Notice that it is legal to set both *Gi_Loading_On_Gate* and *Gi_Loading_On_TC* to 1 simultaneously. Related bitfields: *Gi_Trigger_Mode_For_Edge_Gate*.

***Gi*_Loading_On_TC**

<i>i</i> = 0	bit: 12	type: Write	in: G0_Mode_Register	address: 26
<i>i</i> = 1	bit: 12	type: Write	in: G1_Mode_Register	address: 27

This bit determines the counter behavior on TC:

- 0: Roll over on TC.
- 1: Reload on TC.

Notice that it is legal to set both *Gi_Loading_On_Gate* and *Gi_Loading_On_TC* to 1 simultaneously.

***Gi*_Next_Load_Source_St**

<i>i</i> = 0	bit: 4	type: Read	in: G_Status_Register	address: 4
<i>i</i> = 1	bit: 5	type: Read	in: G_Status_Register	address: 4

This bit indicates the next load source of general-purpose counter *i*:

- 0: Load register A.
- 1: Load register B.

***Gi*_No_Load_Between_Gates_St**

<i>i</i> = 0	bit: 10	type: Read	in: G_Status_Register	address: 4
<i>i</i> = 1	bit: 11	type: Read	in: G_Status_Register	address: 4

This bit indicates that a counter reload did not occur for general-purpose counter *i* between two relevant G_GATE edges.

Gi_OR_Gate

<i>i</i> = 0	bit: 13	type: Write	in: G0_Input_Select_Register	address: 36
<i>i</i> = 1	bit: 13	type: Write	in: G1_Input_Select_Register	address: 37

This bit determines whether the selected gate signal is OR-ed with the output of the other general-purpose counter:

- 0: No.
- 1: Yes.

You can use setting 1 for hardware-triggered buffered pulse-train generation. The selected gate signal is only OR-ed while the counter is not counting. When the counter is counting, only the output of the other counter applies.

Gi_Output_Mode

<i>i</i> = 0	bits: <8..9>	type: Write	in: G0_Mode_Register	address: 26
<i>i</i> = 1	bits: <8..9>	type: Write	in: G1_Mode_Register	address: 27

This bit selects the mode for the G_OUT signal:

- 0: Reserved.
- 1: TC mode. The counter TC signal appears on G_OUT.
- 2: Toggle output on TC mode. G_OUT changes state on the trailing edge of counter TC.
- 3: Toggle output on TC or gate mode. G_OUT changes state on the trailing edge of counter TC and on the active gate edge. This mode can be used for sequential scanning.

Related bitfields: *Gi_Output_Polarity*.

Gi_Output_Polarity

<i>i</i> = 0	bit: 14	type: Write	in: G0_Input_Select_Register	address: 36
<i>i</i> = 1	bit: 14	type: Write	in: G1_Input_Select_Register	address: 37

This bit selects the polarity of the G_OUT pulse (in the TC mode) or the initial G_OUT level (in the toggle output mode):

- 0: Active high pulse or initial low level.
- 1: Active low pulse or initial high level.

Related bitfields: *Gi_Output_Mode*.

Gi_Output_St

<i>i</i> = 0	bit: 0	type: Read	in: Joint_Status_2_Register	address: 29
<i>i</i> = 1	bit: 1	type: Read	in: Joint_Status_2_Register	address: 29

This bit indicates the current G_OUT state (after the polarity selection):

- 0: Low.
- 1: High.

Related bitfields: *Gi_Output_Polarity*.

Gi_Permanent_Stale_Data_St

<i>i</i> = 0	bit: 14	type: Read	in: Joint_Status_2_Register	address: 29
<i>i</i> = 1	bit: 15	type: Read	in: Joint_Status_2_Register	address: 29

This bit indicates the detection of a permanent stale data error:

- 0: No error.
- 1: Error.

A permanent stale data error occurs if *Gi_Stale_Data_St* was set at any time during an interrupt-driven noncumulative-event counting or period-measurement operation. This is useful for after-the-fact error detection.

Gi_Read_Acknowledges_Irq

<i>i</i> = 0	bit: 0	type: Write	in: G0_Input_Select_Register	address: 36
<i>i</i> = 1	bit: 0	type: Write	in: G1_Input_Select_Register	address: 37

Setting this bit to 1 causes hardware save register accesses to clear *Gi_Gate_Interrupt_St* and to reset the associated interrupt latency error-detection circuitry. To select between the high/low save register, use *Gi_Little_Big_Endian*. Do not set this bit to 1 if *Gi_Write_Acknowledges_Irq* is set to 1. Related bitfields: *Gi_Gate_Interrupt_St*, *Gi_Little_Big_Endian*.

Gi_Reload_Source_Switching

<i>i</i> = 0	bit: 15	type: Write	in: G0_Mode_Register	address: 26
<i>i</i> = 1	bit: 15	type: Write	in: G1_Mode_Register	address: 27

If *Gi_Gate_Select_Load_Source* is set to 0, this bit enables load register selection in the following manner:

- 0: Always use the same load register.
- 1: Alternate between the two load registers.

Related bitfields: *Gi_Gate_Select_Load_Source*.

Gi_Reset

<i>i</i> = 0	bit: 2	type: Strobe	in: Joint_Reset_Register	address: 72
<i>i</i> = 1	bit: 3	type: Strobe	in: Joint_Reset_Register	address: 72

Setting this bit to 1 resets the counter, clears *Gi_Arm* and *Gi_Arm_Copy*, clears the *G0_Mode_Register*, and clears the appropriate bits of the *G_Input_Select_Register*. This bit is cleared automatically.

Gi_Save_St

<i>i</i> = 0	bit: 0	type: Read	in: G_Status_Register	address: 4
<i>i</i> = 1	bit: 1	type: Read	in: G_Status_Register	address: 4

This bit indicates the status of the general-purpose counter *i* save register:

- 0: Save register is tracing the counter.
- 1: Save register is latched for later read.

Related bitfields: *Gi_Save_Trace*.

Gi_Save_Trace

<i>i</i> = 0	bit: 1	type: Write	in: G0_Command_Register	address: 6
<i>i</i> = 1	bit: 1	type: Write	in: G1_Command_Register	address: 7

Setting this bit or *Gi_Save_Trace_Copy* to 1 places the general-purpose counter *i* save register in the latched data state. Setting both this bit and *Gi_Save_Trace_Copy* to 0 makes the save register trace the counter. To latch the counter contents in the save register, you must make the save register trace the counter before issuing the save command.

Gi_Save_Trace_Copy

<i>i</i> = 0	bit: 14	type: Write	in: G1_Command_Register	address: 7
<i>i</i> = 1	bit: 14	type: Write	in: G0_Command_Register	address: 6

Setting this bit or *Gi_Save_Trace* to 1 places the general-purpose counter *i* save register in the latched data state. Setting both this bit and *Gi_Save_Trace* to 0 makes the save register trace the counter. To latch the counter contents in the save register, you must make the save register trace the counter before issuing the save command.

Gi_Save_Value

<i>i</i> = 0	bits: <0..7>	type: Read	in: G0_Save_Registers	address: 12
	bits: <0..15>	type: Read	in: G0_Save_Registers	address: 13
<i>i</i> = 1	bits: <0..7>	type: Read	in: G1_Save_Registers	address: 14
	bits: <0..15>	type: Read	in: G1_Save_Registers	address: 15

When *Gi_Save_Trace* and *Gi_Save_Trace_Copy* are both 0, this bitfield reflects the contents of general-purpose counter *i*. When you set *Gi_Save_Trace* or *Gi_Save_Trace_Copy* to 1, this bitfield synchronously latches the contents of the counter using the counter source. The eight MSBs are located at the lower address and the 16 LSBs are located at the higher address. Related bitfields: *Gi_Save_Trace*, *Gi_Save_Trace_Copy*.

***Gi*_Source_Polarity**

<i>i</i> = 0	bit: 15	type: Write	in: G0_Input_Select_Register	address: 36
<i>i</i> = 1	bit: 15	type: Write	in: G1_Input_Select_Register	address: 37

This bit selects the active edge of the general-purpose counter *i* source:

- 0: Rising edge.
- 1: Falling edge.

Related bitfields: *Gi*_Source_Select.

***Gi*_Source_Select**

<i>i</i> = 0	bits: <2..6>	type: Write	in: G0_Input_Select_Register	address: 36
<i>i</i> = 1	bits: <2..6>	type: Write	in: G1_Input_Select_Register	address: 37

This bitfield selects the general-purpose counter *i* source:

- 0: The internal signal G_IN_TIMEBASE1.
- 1-10: PFI<0..9>.
- 11-17: RTSI_TRIGGER<0..6>.
- 18: The internal signal IN_TIMEBASE2.
- 19: The G_TC signal from the other general-purpose counter.
- 31: Logic low.

***Gi*_Stale_Data_St**

<i>i</i> = 0	bit: 6	type: Read	in: G_Status_Register	address: 4
<i>i</i> = 1	bit: 7	type: Read	in: G_Status_Register	address: 4

This bit indicates that no source edge was detected between two adjacent relevant gate edges. This bit is used for noncumulative event counting and period measurement.

***Gi*_Stop_Mode**

<i>i</i> = 0	bits: <5..6>	type: Write	in: G0_Mode_Register	address: 26
<i>i</i> = 1	bits: <5..6>	type: Write	in: G1_Mode_Register	address: 27

This bit selects the condition on which the counter will stop:

- 0: Stop on gate condition.
- 1: Stop on gate condition or at the first TC, whichever comes first.
- 2: Stop by gate condition or at the second TC, whichever comes first.
- 3: Reserved.

Notice that, regardless of this bitfield setting, you can always use the software disarm command, *Gi*_Disarm, to stop the counter. The gate condition that stops the counter is determined by *Gi*_Gating_Mode (in case of level gating) or by a combination of *Gi*_Gating_Mode and *Gi*_Trigger_Mode_For_Edge_Gate (in case of edge gating). Selections 1 and 2 are valid only if *Gi*_Trigger_Mode_For_Edge_Gate is set to 2 (no hardware limit on this). Related bitfields: *Gi*_Disarm, *Gi*_Gating_Mode, *Gi*_Trigger_Mode_For_Edge_Gate.

***Gi*_Synchronized_Gate**

<i>i</i> = 0	bit: 8	type: Write	in: G0_Command_Register	address: 6
<i>i</i> = 1	bit: 8	type: Write	in: G1_Command_Register	address: 7

This bit enables gate synchronization to the source:

- 0: Disabled.
- 1: Enabled.

You should normally set this bit to 1. You can set this bit to 0 if you know that the gate signal is synchronized to the source signal.

***Gi*_TC_Error_Confirm**

<i>i</i> = 0	bit: 6	type: Strobe	in: Interrupt_A_Ack_Register	address: 2
<i>i</i> = 1	bit: 2	type: Strobe	in: Interrupt_B_Ack_Register	address: 3

Setting this bit to 1 clears *Gi*_TC_Error_St. This bit is cleared automatically. Related bitfields: *Gi*_TC_Error_St.

***Gi*_TC_Error_St**

<i>i</i> = 0	bit: 12	type: Read	in: G_Status_Register	address: 4
<i>i</i> = 1	bit: 13	type: Read	in: G_Status_Register	address: 4

This bit indicates the detection of a TC latency error:

- 0: No.
- 1: Yes.

A TC latency error is detected if *Gi*_TC_Interrupt_Ack is not set between two counter TCs. This allows you to detect large interrupt latencies and potential problems associated with them. To clear this bit, set *Gi*_TC_Error_Confirm to 1. Related bitfields: *Gi*_TC_Interrupt_Ack, *Gi*_TC_Error_Confirm.

***Gi*_TC_Interrupt_Ack**

<i>i</i> = 0	bit: 14	type: Strobe	in: Interrupt_A_Ack_Register	address: 2
<i>i</i> = 1	bit: 14	type: Strobe	in: Interrupt_B_Ack_Register	address: 3

Setting this bit to 1 clears *Gi*_TC_St and acknowledges the TC interrupt request (in either interrupt bank) if the TC interrupt is enabled. This bit is cleared automatically. Related bitfields: *Gi*_TC_St.

Gi_TC_Interrupt_Enable

$i = 0$	bit: 6	type: Write	in: Interrupt_A_Enable_Register	address: 73
$i = 1$	bit: 9	type: Write	in: Interrupt_B_Enable_Register	address: 75

This bit enables the TC interrupt:

- 0: Disabled.
- 1: Enabled.

The TC interrupt occurs on the rising edge of the counter TC.

Gi_TC_Second_Irq_Enable

$i = 0$	bit: 6	type: Write	in: Second_Irq_A_Enable_Register	address: 74
$i = 1$	bit: 9	type: Write	in: Second_Irq_B_Enable_Register	address: 76

This bit enables the TC interrupt in the secondary interrupt bank:

- 0: Disabled.
- 1: Enabled.

The TC interrupt occurs on the rising edge of the counter TC.

Gi_TC_St

$i = 0$	bit: 3	type: Read	in: AI_Status_1_Register	address: 2
$i = 1$	bit: 3	type: Read	in: AO_Status_1_Register	address: 3

This bit indicates whether general-purpose counter i has reached TC:

- 0: No.
- 1: Yes.

You can use this bit for overflow detection in some applications. This bit is cleared by setting *Gi_TC_Interrupt_Ack* to 1. Related bitfields: *Gi_TC_Interrupt_Ack*. Refer to Table 8-2, [Interrupt Condition Summary](#), for more information.

Gi_Trigger_Mode_For_Edge_Gate

$i = 0$	bits: <3..4>	type: Write	in: G0_Mode_Register	address: 26
$i = 1$	bits: <3..4>	type: Write	in: G1_Mode_Register	address: 27

This bit selects the triggering mode, if gating is not disabled:

- 0: The first gate edge starts, the next stops the counting.
- 1: The first gate edge stops, the next starts the counting.
- 2: Gate edge always starts the counting, unless counting is already in progress, in which case the edge is ignored. The valid *Gi_Stop_Mode* settings for this selection are 1 and 2, but only the TC (not the gate) will stop the counting.
- 3: Gate is used for reload, save, or load select only, if any of those options is enabled; not for stopping.

Selections 0 and 1 are valid only if *Gi_Stop_Mode* is set to 0 (no hardware limit on this). Selections 0, 1, and 2 are valid only if *Gi_Gating_Mode* is set to 2 or 3. Selection 3 is valid only if *Gi_Gating_Mode* is not set to 0. Related bitfields: *Gi_Gating_Mode*, *Gi_Stop_Mode*.

***Gi*_Up_Down**

<i>i</i> = 0	bits: <5..6>	type: Write	in: G0_Command_Register	address: 6
<i>i</i> = 1	bits: <5..6>	type: Write	in: G1_Command_Register	address: 7

This bit selects the up/down mode:

0: Software-selected down counting.

1: Software-selected up counting.

2: Hardware-selected up/down counting controlled by the G_UP_DOWN*i* input pins:
Logic low: Count down.

Logic high: Count up.

3: Hardware-selected up/down counting controlled by the internal gate value
(see G_Gating_Polarity):

Active gate level: Count up.

Inactive gate level: Count down.

Selection can be changed while the counter is counting. Related bitfields:

*Gi*_Gating_Polarity.

***Gi*_Write_Acknowledges_Irq**

<i>i</i> = 0	bit: 1	type: Write	in: G0_Input_Select_Register	address: 36
<i>i</i> = 1	bit: 1	type: Write	in: G1_Input_Select_Register	address: 37

Setting this bit to 1 causes load register write accesses to clear *Gi*_TC_St and to reset the associated interrupt latency error-detection circuitry. To select between the high/low load register, use *Gi*_Little_Big_Endian. Do not set this bit to 1 if *Gi*_Read_Acknowledge_Irq is set to 1. Related bitfields: *Gi*_TC_St, *Gi*_Little_Big_Endian.

***Gi*_Write_Switch**

<i>i</i> = 0	bit: 7	type: Write	in: G0_Command_Register	address: 6
<i>i</i> = 1	bit: 7	type: Write	in: G1_Command_Register	address: 7

This bit enables the write switch feature of the general-purpose counter *i* load registers.

Writes to load register A are:

0: Unconditionally directed to load register A.

1: Directed to the inactive load register.

GPFO_0_Output_Enable

bit: 14	type: Write	in: Analog_Trigger_Etc_Register	address: 61
---------	-------------	---------------------------------	-------------

This bit configures the G_OUT0/RTSI_IO bidirectional pin:

0: Input. Use this pin to route an external signal to the RTSI_TRIGGER bus.
See RTSI_Trig_*i*_Output_Select

1: Output. Use GPFO_0_Output_Select to select the output signal.

Related bitfields: RTSI_Trig_*i*_Output_Select, GPFO_0_Output_Select.

GPFO_0_Output_Select

bits: <11..13> **type:** Write **in:** Analog_Trigger_Etc_Register **address:** 61

This bit selects the output source for the G_OUT0/RTSI_IO bidirectional pin if the pin is configured for output:

- 0: General-purpose counter 0 output (G_OUT).
- 1–7: Signal from the RTSI trigger line <0..6>.

Related bitfields: GPFO_0_OUTPUT_Enable.

GPFO_1_Output_Enable

bit: 15 **type:** Write **in:** Analog_Trigger_Etc_Register **address:** 61

This bit enables the G_OUT1/DIV_TC_OUT output signal:

- 0: Disabled.
- 1: Enabled.

GPFO_1_Output_Select

bit: 7 **type:** Write **in:** Analog_Trigger_Etc_Register **address:** 61

This bit selects the output source for the G_OUT1/DIV_TC_OUT output signal, if enabled for output:

- 0: General-purpose counter 1 output (G_OUT).
- 1: The internal analog input signal DIV_TC.

Related bitfields: GPFO_1_OUTPUT_Enable.

G_Source_Divide_By_2

bit: 10 **type:** Write **in:** Clock_and_FOUT_Register **address:** 56

This bit determines the frequency of the internal timebase G_IN_TIMEBASE:

- 0: Same as IN_TIMEBASE.
- 1: IN_TIMEBASE divided by 2.

4.7 Timing Diagrams

All timing in this section refers to timing between pins. Since many of the timing parameters are defined based on internal signals and the internal signals can be selected from a variety of sources, it is convenient to define some global signals that can refer to any one of a number of pins depending on the internal signal selection.

Some of the tables in this section indicate that OSC is the reference pin, with `RTSI_OSC` included in parentheses. This indicates that you can use the `RTSI_Clock_Mode` to choose between OSC and `RTSI_OSC` as the reference pin.

`CTRSRC` represents the signal that causes the counter to increment or decrement. Table 4-1 indicates the pin represented by `CTRSRC` based on internal selection.

Table 4-1. CTRSRC Reference Pin Selection

<code>Gi_Source_Select</code>	Reference Pin
0	OSC (or <code>RTSI_OSC</code>)
1–10	<code>PFI<0..9></code>
11–17	<code>RTSI_TRIGGER<0..6></code>
18	OSC (or <code>RTSI_OSC</code>)
19	The counter source is selected to be the output of the other general-purpose counter. The reference pin is determined by the <code>Gi_Source_Select</code> bitfield of the other counter. To determine delays for this case, the source to output delay (T_{so}) from the other counter must be added.

When OSC (or `RTSI_OSC`) is the selected reference, the counter is in the internal timing mode. In this mode, `GTRGATE` and `CTR_U/D` are synchronized to the inactive edge of `CTRSRC`, while the counter changes state on the active edge of `CTRSRC`.

When any other pin is the selected reference, the counter is in the external timing mode. In this mode, `CTRGATE` and `CTR_U/D` are synchronized to the active edge of `CTRSRC` before it enters a delay gate, while the counter changes state on the active edge of `CTRSRC` after it passes through the delay gate. The delay gate is provided so that the signals synchronized to the early version of `CTRSRC` have sufficient time to settle to a known state before being used by the counter.

CTRGATE represents the signal that gates the counting operation of the counter. Table 4-2 indicates the pin represented by CTRGATE based on internal selection.

Table 4-2. CTRGATE Reference Pin Selection

Gi_Gate_Select	Reference Pin
1–10	PFI<0..9>
11–17	RTSI_TRIGGER<0..6>
18	The counter gate is selected to be AI_START2. The reference pin is determined by AO_START2_Select. To determine delays for this case, the source to AO_START2 delay must be added.
19	The counter gate is selected to be UI2_TC. The reference pin is determined by AO_UI2_Source_Select. To determine delays for this case, the UI2 source to TC delay must be added.
20	The counter gate is selected to be the output of the other general-purpose counter. The reference pin is determined by the Gi_Source_Select bitfield of the other counter. To determine delays for this case, the source to output delay (Tso) from the other counter must be added.
21	The counter gate is selected to be AI_START1. The reference pin is determined by AO_START1_Select. To determine delays for this case, the source to AO_START1 delay must be added.

CTR_U/D represents the signal that causes the counter to count up or down. Table 4-3 indicates the pin represented by CTR_U/D based on internal selection.

Table 4-3. CTR_U/D Reference Pin Selection

Gi_Up_Down_Mode	Reference Pin
2	G_UP_DOWN <i>i</i>
3	Same reference pin as selected by CTRGATE Reference Pin Selection

CTROUT refers to following pins:

- G_OUT0/RTSI_OUT
- G_OUT1/DIV_TC_OUT

INTERRUPT refers to the following pins:

- IRQ_OUT<0..7>
- SEC_IRQ_OUT_BANK<0..1>

4.7.1 CTRSRC Minimum Period and Minimum Pulsewidth

Figure 4-21 and the accompanying table indicate the minimum period and minimum pulsewidth for the general-purpose counter source signal, CTRSRC.

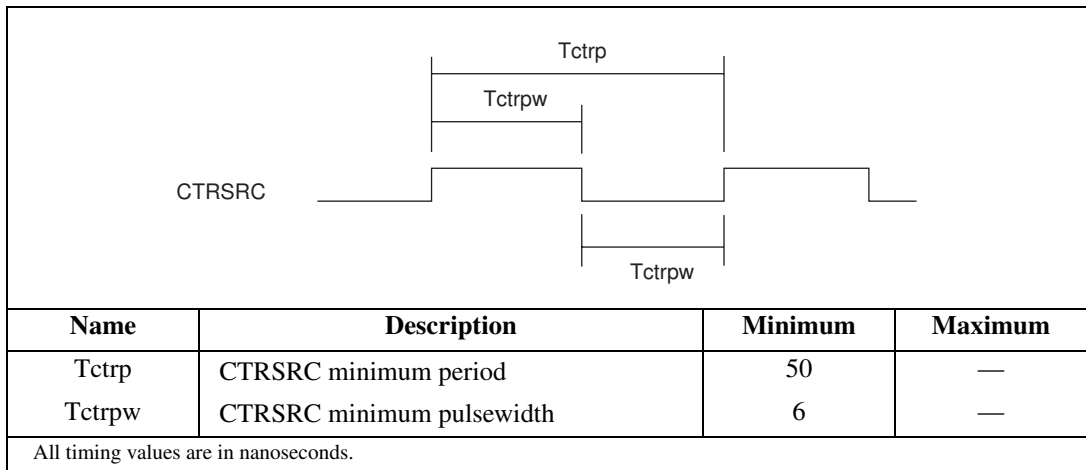

Figure 4-21. CTRSRC Minimum Period and Minimum Pulsewidth



Note

If simple loop counting is the only functionality required for the counter, then the frequency of operation may be increased. For simple loop counting, the counter has been shown to function at CTRSRC periods as small as 33 ns.

4.7.2 CTRSRC to CTROUT Delay

Figure 4-22 and the accompanying table indicate the delay from the counter source signal (CTRSRC) to the counter output signal (CTROUT). If the CTRSRC is selected to be the output of the other general-purpose counter, then you must add the T_{so} delays from each counter to determine the total source to output delay. For example, if general-purpose counter 0 selects OSC for its source and general-purpose counter 1 selects the output of general-purpose 0 for its source, then the total delay (OSC to the CTROUT of general-purpose counter 1) will be 18 + 27 = 45 (MIN) and 55 + 80 = 135 (MAX).

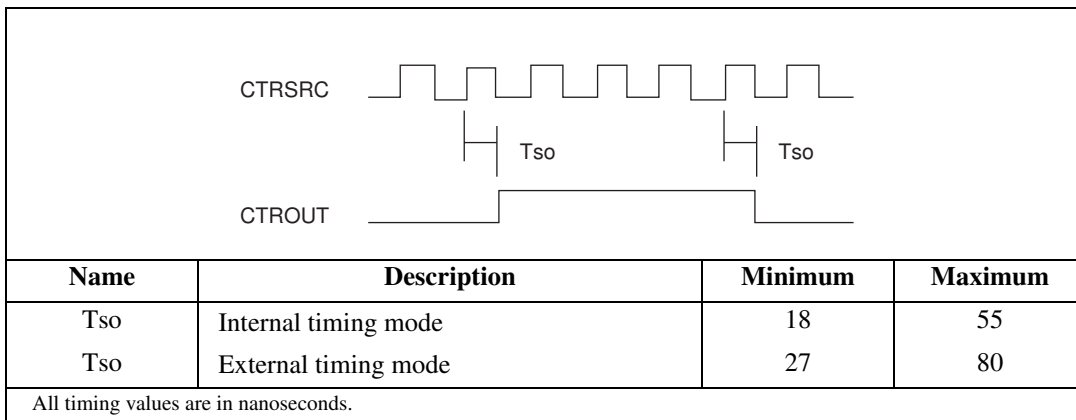

Figure 4-22. CTRSRC to CTROUT Timing

4.7.3 G_GATE Minimum Pulsewidth

Figure 4-23 and the accompanying table indicate the minimum pulsewidth for the general-purpose counter gate signal, CTRGATE.

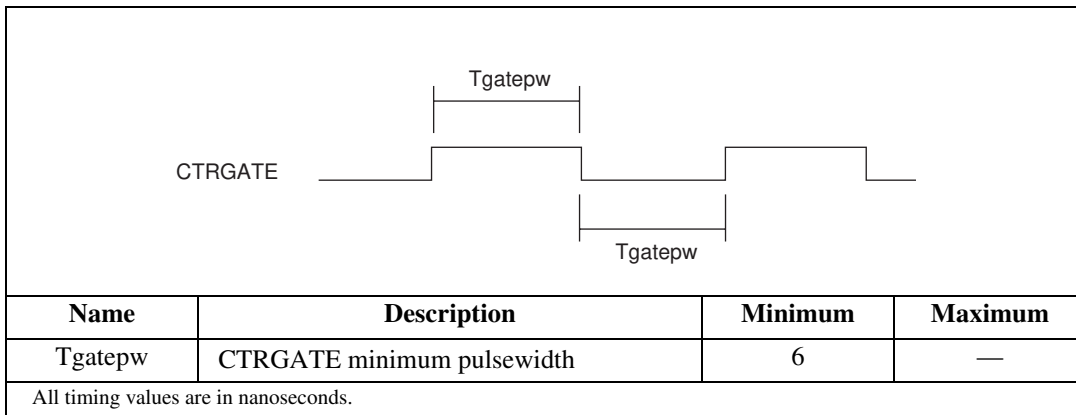

Figure 4-23. G_GATE Minimum Pulsewidth

4.7.4 CTRGATE to CTROUT Delay

When *Gi_Output_Mode* is set to 3, the counter output (CTROUT) is asynchronously controlled by the counter gate (CTRGATE). Figure 4-24 and the accompanying table indicate the delay from CTRGATE to CTROUT when the output is being controlled by the gate.

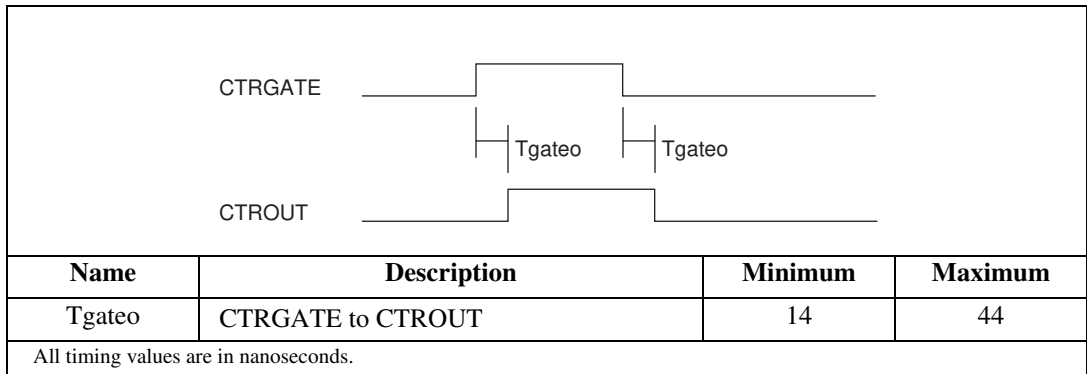

Figure 4-24. CTRGATE to CTROUT Timing

4.7.5 CTRGATE to INTERRUPT

When *Gi_Gate_Interrupt_Enable* is set to 1, interrupts are generated based on CTRGATE. The deassertion of INTERRUPT occurs when software clears the register bit causing the interrupt. Figure 4-21 and the accompanying table indicate the delay from CTRGATE to INTERRUPT when the counter gate generates an interrupt.

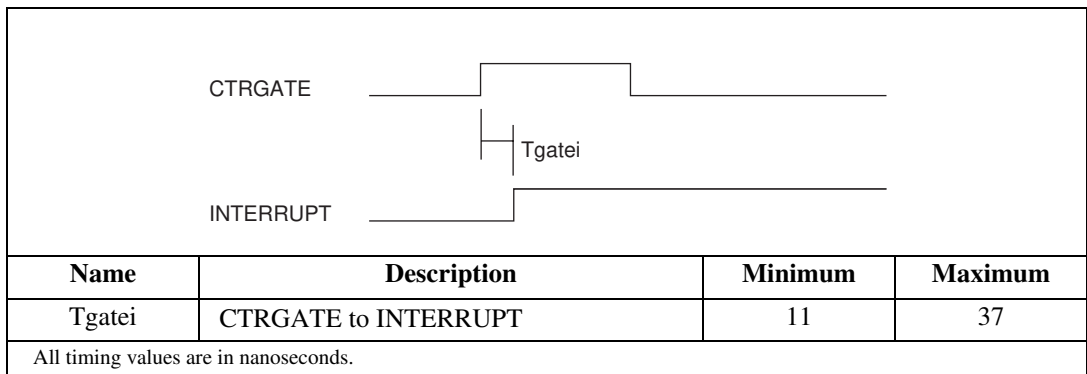

Figure 4-25. CTRGATE to INTERRUPT Timing

4.7.6 CTRGATE Setup

In many GPCT functions (for example, simple gated event counting) the gate signal causes the counter to start and stop counting. In these functions, CTRGATE is usually synchronized to the falling edge of CTRSRC before being used by the counter. In order for CTRGATE to be recognized, it must stabilize at least one setup time before the relevant edge of CTRSRC.

In the internal timing mode, CTRGATE is synchronized to the inactive edge of CTRSRC. In the external timing mode, CTRGATE is synchronized to the active edge of CTRSRC before it enters a delay gate. Figures 4-26 and 4-27, and the accompanying table indicate the setup time requirements for CTRGATE relative to the relevant edge of CTRSRC.

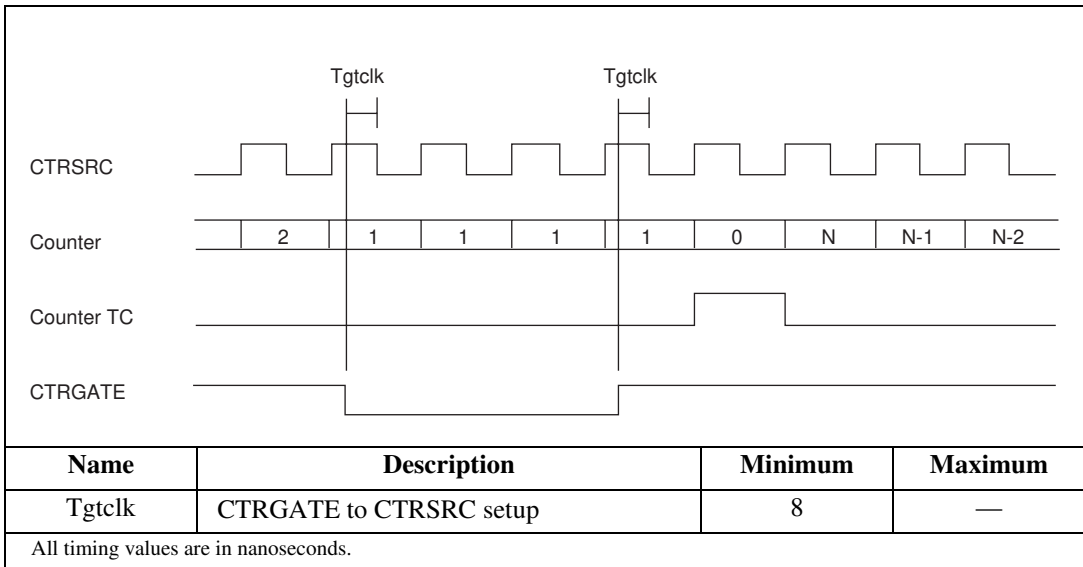

Figure 4-26. CTRGATE Setup Timing, Internal Timing Mode

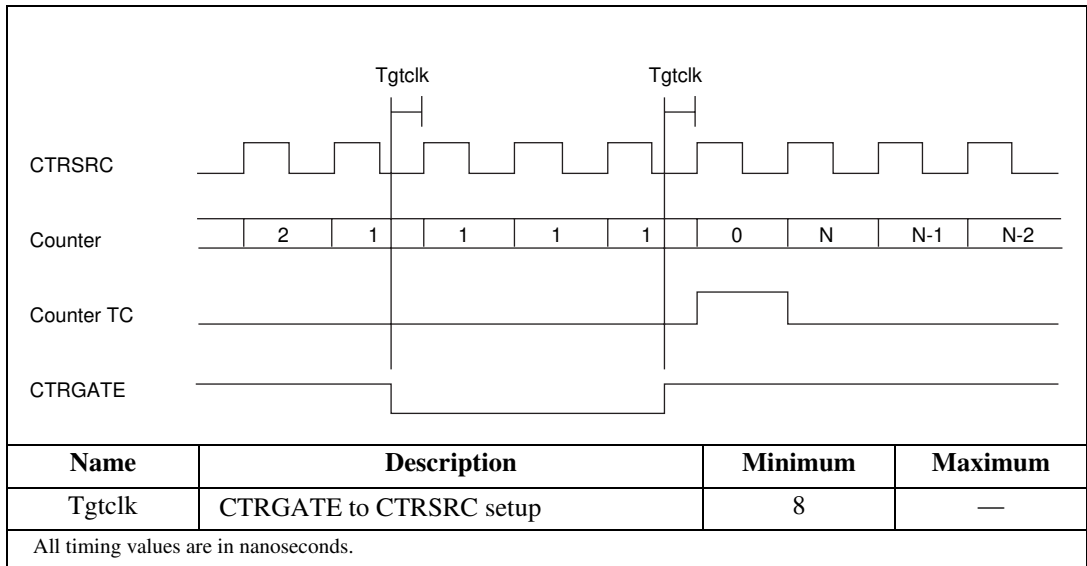

Figure 4-27. CTRGATE Setup Timing, External Timing Mode

4.7.7 CTR_U/D Setup

In many GPCT functions (for example, relative position sensing) the CTR_U/D signal causes the counter to select between up counting and down counting. In these functions, CTR_U/D is synchronized to CTRSRC before being used by the counter. In order for CTR_U/D to be recognized, it must stabilize at least one setup time before the relevant edge of CTRSRC.

In the internal timing mode, CTR_U/D is synchronized to the inactive edge of CTRSRC. In the external timing mode, CTR_U/D is synchronized to the active edge of CTRSRC before it enters a delay gate. Figures 4-28 and 4-29, and the accompanying table indicate the setup time requirements for CTR_U/D relative to the relevant edge of CTRSRC.

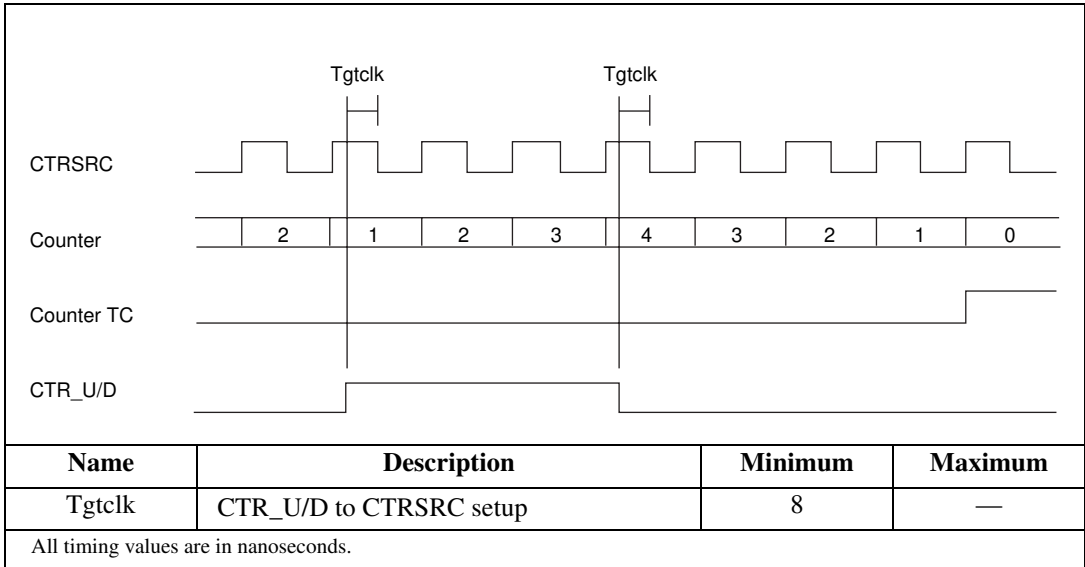

Figure 4-28. CTR_U/D Setup Timing, Internal Timing Mode

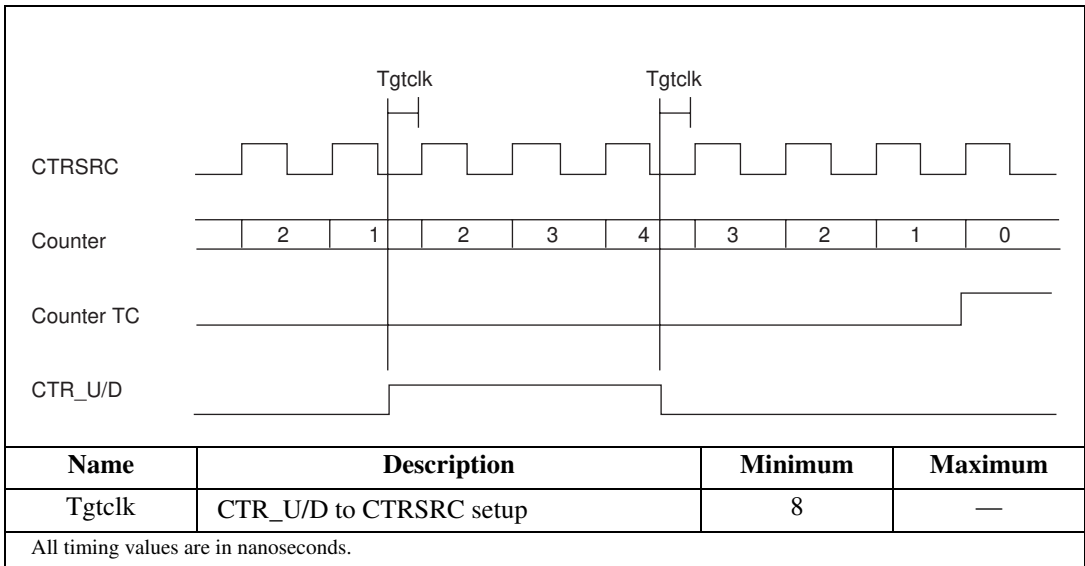

Figure 4-29. CTR_U/D Setup Timing, External Timing Mode

4.8 Detailed Description

This section provides a detailed description of the GPCT. The discussion refers to bitfields in the DAQ-STC register map. You can find the register-level information for these bitfields in section 4.6, *Programming Information*.

The GPCT module contains two identical 24-bit binary up/down counters. Figure 4-30 shows a model of the counter.

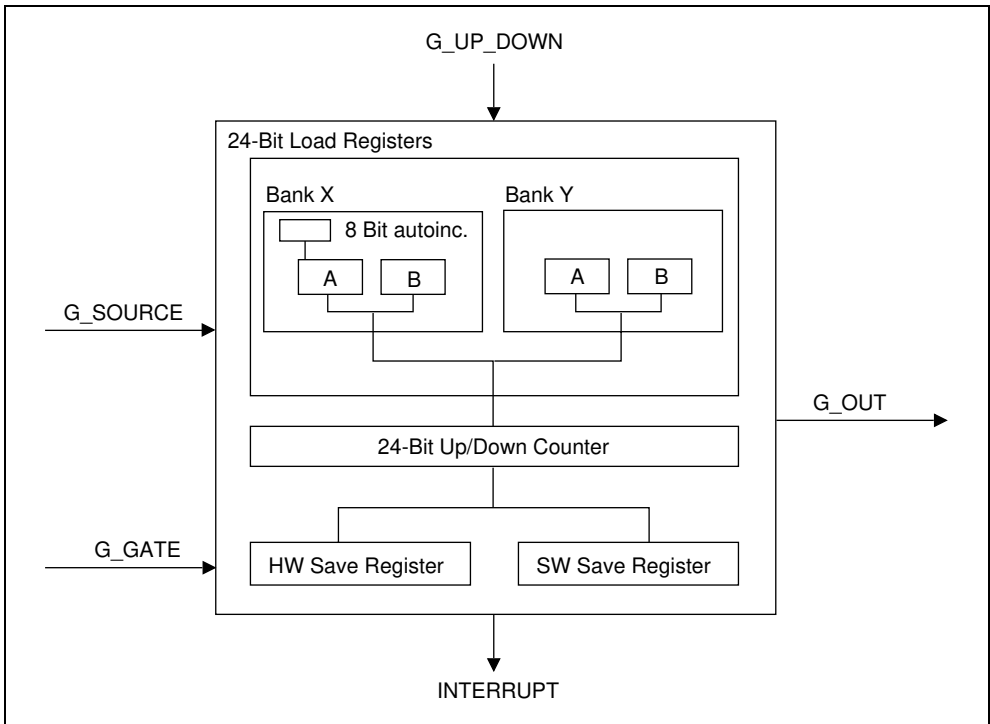

Figure 4-30. General-Purpose Counter/Timer Model

The two counters are identical except in the routing of their output signal **G_OUT**. Refer to section 4.8.5, *G_OUT Conditioning and Routing*, for more information.

Each counter has two banks of load registers, designated bank X and bank Y. Each bank contains two 24-bit load registers, designated load register A and load register B. The load registers allow a seamless change of counter load parameters in the pulse-generation functions (for example, in buffered pulse-train generation). Load register A in bank X has a special autoincrement feature that is used in pulse-train generation for ETS. Each time the counter reloads from the load register, the autoincrement circuit adds a constant fixed value

to the load register, so that on the next reload the counter will load the incremented value. Refer to *Gi_Autoincrement* for more information.

Each counter also has two 24-bit save registers, designated the hardware save register (HW_Save_Register) and the software save register (SW_Save_Register). The G_GATE signal latches the counter contents into the HW_Save_Register. Thus, the hardware determines the time that the counter contents are saved, hence the name HW_Save_Register. The HW_Save_Register makes possible buffer-oriented, interrupt-driven period and pulsewidth measurements. The DAQ-STC provides error-detection mechanisms for cases where gap-free readings are not possible due to the interrupt latency of the system. The software save register provides the ability to peek at the counter contents any time without disturbing any buffer-oriented measurements. The software save registers enable the software to monitor the counter contents for status reporting.

4.8.1 Internal Signals and Operation

Table 4-4 lists internal signals used in the GPCT hardware description and their relationship to the external signals.

Table 4-4. Internal Signal Description

Signal	Description
G_CONTROL	Counter Control—The hardware generates G_CONTROL by passing G_GATE through the G_CONTROL conditioning circuit.
G_GATE	Counter Gate—G_GATE can come from two sources. If <i>Gi_OR_Gate</i> is set to 0, the hardware generates G_GATE by passing the output of the <i>Gi_Gate</i> selector through polarity selection. If <i>Gi_OR_Gate</i> is set to 1, the hardware generates G_GATE by passing the output of the <i>Gi_Gate</i> selector through polarity selection and OR-ing the result with the output of the other general-purpose counter.
G_IN_TIMEBASE1	Internal Timebase—G_IN_TIMEBASE1 is the internal timebase for the general-purpose counter/timer module. G_IN_TIMEBASE1 can be the same as IN_TIMEBASE, or it can be IN_TIMEBASE divided by two. Related bitfields: <i>G_Source_Divide_By_2</i> .
G_SOURCE	Counter Source—The hardware generates G_SOURCE by passing the output of the <i>Gi_Source</i> selector through polarity selection. Related bitfields: <i>Gi_Source_Select</i> .
G_TC	Counter TC—G_TC is the actual general-purpose counter TC signal.
G_OUT	Counter Output—G_OUT is the G_TC signal after output and polarity selection. Related bitfields: <i>Gi_Output_Mode</i> , <i>Gi_Output_Polarity</i> .

Table 4-4. Internal Signal Description (Continued)

Signal	Description
IN_TIMEBASE2	Slow Internal Timebase—This timebase is derived from the IN_TIMEBASE input and is usually configured to be 100 kHz. Related bitfields: Slow_Internal_Time_Divide_By_2, Slow_Internal_Timebase.
RGOUT0	RTSI Counter Output—RGOUT0 can come from two sources. If RTSI_Sub_Selection_1 is 0, RGOUT0 is the G_OUT signal from general-purpose counter 0. If RTSI_Sub_Selection_1 is 1, RGOUT0 is the signal appearing on the G_OUT0/RTSI_IO pin.

4.8.2 G_SOURCE Selection and Conditioning

The hardware can route any of the PFI or the RTSI_TRIGGER pins to the input G_SOURCE. In addition, G_SOURCE can come from a few internal signals. The user can select the active edge polarity (rising edge active or falling edge active). Table 4-5 shows a comprehensive list of the signal sources available for G_SOURCE.

Table 4-5. G_SOURCE Selection

<i>G</i> _i _Source_Select	Source
0	Internal signal G_IN_TIMEBASE1
1–10	PFI<0..9>
11–17	RTSI_TRIGGER<0..6>
18	Internal signal IN_TIMEBASE2
19	G_TC signal from the other general-purpose counter



Note *On the AT-MIO E Series boards, the OSC pin is tied to 20 MHz. The G_IN_TIMEBASE1 has possible values of 20 MHz and 10 MHz, and IN_TIMEBASE2 is 100 kHz.*

Table 4-6 shows the conditioning available for G_SOURCE.

Table 4-6. G_SOURCE Conditioning

<i>G</i> _i _Source_Polarity	Polarity
0	Rising edge active
1	Falling edge active

4.8.3 G_GATE Selection and Conditioning

The G_GATE signal controls the counter operation. The signal has two states, ACTIVE and INACTIVE. Table 4-7 shows the input routing for the G_GATE signal.

Table 4-7. G_GATE Selection

Gi_Gate_Select	Source
1–10	PFI<0..9>
11–17	RTSI_TRIGGER<0..6>
18	Internal analog input signal START2
19	Internal analog output signal UI2_TC
20	G_OUT signal from general-purpose counter 0
21	Internal analog input signal START1

Table 4-8 shows the input conditioning for the G_GATE signal.

Table 4-8. G_GATE Conditioning

Gi_Gate_Polarity	Polarity
0	G_GATE is ACTIVE when input is high
1	G_GATE is ACTIVE when input is low

4.8.4 G_UP_DOWN Control

You can route the up/down control input from a dedicated up/down input pin (G_UP_DOWN) for each counter. Alternately, the G_GATE input can serve as the direction control input. The motivation for G_GATE signal serving as the direction control is that some board implementations may not connect the dedicated G_UP_DOWN pins to the I/O connector because of pin count limitations.



Note *On the E Series boards, the UP_DOWN control inputs G_UP_DOWN0 and G_UP_DOWN1 pins are tied together with the DIO <6..7>.*

Table 4-9. G_UP_DOWN Modes

Gi_Up_Down_Mode	Description
0	Software-selected down counting. The hardware control signals G_UP_DOWN<0..1> are ignored.
1	Software-elected up counting. The hardware control signals G_UP_DOWN<0..1> are ignored.
2	The G_UP_DOWN _i pin controls the direction of counting. Down counting on low level and up counting on high level.
3	G_GATE signal controls the direction. G_GATE is ACTIVE—count up. G_GATE is INACTIVE—count down.

4.8.5 G_OUT Conditioning and Routing

Table 4-10 lists the conditioning available for the counter output signal G_OUT.

Table 4-10. G_OUT Mode

Gi_Output_Mode	Description
1	TC Mode. The actual counter TC signal appears on G_OUT.
2	Toggle Output on TC Mode. G_OUT changes state on the trailing edge of counter TC.
3	Toggle Output on TC or Gate Mode. G_OUT changes state on the trailing edge of counter TC and on G_GATE transitions to ACTIVE.

The *Gi_Output_Polarity* bits further condition the output signal G_OUT, as shown in Table 4-11.

Table 4-11. G_OUT Polarity

Gi_Output_Polarity	Description
0	Active high. Output is normally low.
1	Active low. Output is normally high.

The TC related output signal G_OUT routing is not symmetrical for the two counters. Both counter outputs are available on PFI<0..9>. The output of only one counter (counter 0) is available on RTSI_TRIGGER<0..6>.

The counter output pins are G_OUT0/RTSI_IO and G_OUT1/DIV_TC_OUT. As the pin names reflect, these pins have multiplexers on the outputs. Table 4-12 indicates how the bitfield GPFO_0_Output_Select controls the G_OUT0/RTSI_IO pin

Table 4-12. G_OUT0/RTSI_IO Selection

GPFO_0_Output_Select	Selection
0	G_OUT signal from general-purpose counter 0
1–7	RTSI_TRIGGER<0..6>

Table 4-13 indicates how the bitfield GPFO_1_Output_Select controls the G_OUT1/DIV_TC_OUT pin.

Table 4-13. G_OUT1/DIV_TC_OUT Selection

GPFO_1_Output_Select	Selection
0	G_OUT1 signal from general-purpose counter 0
1	Internal analog input signal EXT_DIVTC

EXT_DIVTC is the AITM DIV counter output. The multiplexed functionality on the G_OUT1/DIV_TC_OUT is utilized by the SCXI systems.

GPFO_0_Output_Enable and GPFO_1_Output_Enable control the output enables for these pins.

To facilitate the use of the timing output capability of the GPCT counters, the outputs connect internally to the other DAQ-STC modules. The general-purpose counter 0 output G_OUT connects to the AITM of the DAQ-STC. The general-purpose counter 1 output G_OUT connects to the AOTM of the DAQ-STC. Refer to the appropriate module description for more details.

4.8.6 G_CONTROL Conditioning

The G_CONTROL signal derives from the G_GATE signal and controls the counter operation. G_CONTROL has two states, ACTIVE and INACTIVE. Table 4-14 indicates the input conditioning available for G_CONTROL.

Table 4-14. G_CONTROL Conditioning

Gi_Gating_Mode	Gi_Gate_On_Both_Edges	G_CONTROL Conditioning
0	0	No gating. G_CONTROL always INACTIVE.
1	0	Level gating. G_CONTROL just follows the G_GATE signal.
2	0	Edge gating. G_CONTROL pulses on G_GATE transition to ACTIVE.
3	1	Edge gating (Double Edge). G_CONTROL pulses on both edges of G_GATE.

4.8.7 Gate Actions

Table 4-15 lists the gating actions that are available when gating is enabled.

Table 4-15. Gate Actions

Gate Action	Related Bitfields
START/STOP on G_CONTROL	Gi_Trigger_Mode_For_Edge_Gate; Gi_Stop_Mode
Save on G_CONTROL	None
Reload on G_CONTROL	Gi>Loading_On_Gate; Gi_Trigger_Mode_For_Edge_Gate
UP/DOWN on G_CONTROL	Gi_Up_Down
Generate interrupt on G_GATE	Gi_Gate_Interrupt_Enable
Change output polarity on G_GATE	Gi_Output_Mode
Select load Register on G_CONTROL	Gi_Gate_Select_Load_Source
Disarm Counter on G_CONTROL	Gi_Counting_Once
Switch load bank selection on G_CONTROL	Gi_Bank_Switch_Enable; Gi_Bank_Switch_Mode; Gi_Bank_Switch_Start

4.8.7.1 START/STOP on G_CONTROL

The START/STOP behavior depends upon the G_CONTROL conditioning. The conditioning can be set to no gating, level gating, or edge gating.

With no gating, the counter is always enabled to count.

With level gating, the counter is enabled to count only when the G_CONTROL is ACTIVE unless *Gi_Trigger_Mode_For_Edge_Gate* is set to 3. In this case, the counter is always enabled to count.

With edge gating, several modes of START/STOP counting are available. The START/STOP counting modes are described in the following table.

Table 4-16. START/STOP Modes for Edge Gating

<i>Gi_Trigger_Mode_For_Edge_Gate</i>	Selected START/STOP Mode
0	First <i>Gi_Control</i> ACTIVE edge starts counting; the next ACTIVE edge stops counting.
2	Counter begins counting when G_CONTROL becomes ACTIVE and then remains in the counting state.
3	Counter always enabled to count.

4.8.7.2 Save on G_GATE

If gating is enabled, the counter value is saved in the HW save register on G_GATE. The HW save register is implemented in hardware as a transparent latch. Normally, the latch is in hold mode. On the G_GATE edge that generates an interrupt (refer to Table 4-18) the HW save register switches to transparent mode, causing the latch to load the current counter value. On the next G_SOURCE falling edge, the latch returns to hold mode.

4.8.7.3 Reload on G_CONTROL

Table 4-17. Reload on G_CONTROL Selections

Loading On Gate	GATE/CONTROL Conditioning	Trigger Mode for Edge Gate	Selected Reload Mode
0	X	X	G_CONTROL does not cause counter reload.
1	Level gating	X	Counter reload occurs on G_CONTROL transition to ACTIVE state.

Table 4-17. Reload on G_CONTROL Selections (Continued)

Loading On Gate	GATE/CONTROL Conditioning	Trigger Mode for Edge Gate	Selected Reload Mode
1	Edge gating	0, 1, or 2	Counter reload occurs on G_CONTROL transition to ACTIVE state.
1	Edge gating	3	Counter reload occurs on every G_CONTROL transition.

4.8.7.4 UP/DOWN on G_CONTROL

When G_i _Up_Down is set to 3, the UP/DOWN control is controlled by G_CONTROL. When G_CONTROL is ACTIVE, the counter counts up. When G_CONTROL is INACTIVE, the counter counts down.

4.8.7.5 Generate Interrupt on G_GATE

When G_i _Gate_Interrupt_Enable is set to 1, interrupts are generated based on the following table. Interrupts are generated only when a counter is armed.

Table 4-18. Gate Interrupts

G_CONTROL Conditioning	Gate on Both Edges	Gate Interrupt
Level	0	Interrupt on G_GATE transition to INACTIVE state.
Edge gating	0	Interrupt on every G_GATE transition to active state.
Edge gating (double edge)	1	Interrupt on every G_GATE transition.

4.8.7.6 Change Output Polarity on G_GATE

When G_i _Output_Mode is set to 3, the counter output (G_OUT) toggles on G_GATE transition to ACTIVE and on every counter TC.

4.8.7.7 Select Load Register on G_CONTROL

When G_i _Gate_Select_Load_Source is set to 1, an ACTIVE G_CONTROL selects load register A, and an INACTIVE G_CONTROL selects load register B.

4.8.7.8 Disarm Counter on G_CONTROL

If *Gi_Counting_Once* is set to 2 or 3, the counter is disarmed following the *G_CONTROL* transition that stops the counting.

4.8.7.9 Switch Load Bank Selection on G_CONTROL

If *Gi_Bank_Switch_Enable* is set to 1 and *Gi_Bank_Switch_Mode* is set to 0 and bank switching has been started, an ACTIVE *G_CONTROL* selects bank X and an INACTIVE *G_CONTROL* selects bank Y.

4.8.8 Interrupt Control

The GPCT module contains the hardware necessary for generating software interrupts based on several conditions. The interrupt programming is accomplished using the *Interrupt_A_Enable_Register* (general-purpose counter 0) and the *Interrupt_B_Enable_Register* (general-purpose counter 1). Interrupts remain active until cleared by software. Software can program the interrupts to occur under the following conditions: assertion of counter TC and gate. Refer to Table 4-18 for a description of the gate interrupt conditions.

4.8.9 PFI Selection

Table 4-19 summarizes the selections available for each of the trigger signals through the PFI selector.

Table 4-19. PFI Selectors

MUX	0	1–10	11–17	18	19	20	21	31
G0_Source	G_TB1	PFI<0..9>	RTSI<0..6>	TB2	G1_TC			GND
G0_Gate		PFI<0..9>	RTSI<0..6>	AI_ST2	UI2_TC	GOUT1	AI_ST1	GND
G1_Source	G_TB1	PFI<0..9>	RTSI<0..6>	TB2	G0_TC			GND
G1_Gate		PFI<0..9>	RTSI<0..6>	AI_ST2	UI2_TC	GOUT0	AI_ST1	GND
Key:								
AI_ST1	The internal analog input signal START1.							
AI_ST2	The internal analog input signal START1.							
G0_TC	The G_TC signal from general-purpose counter 0.							
G1_TC	The G_TC signal from general-purpose counter 1.							
GOUT0	The G_OUT signal from general-purpose counter 0.							
GOUT1	The G_OUT signal from general-purpose counter 1.							
G_TB1	The internal signal G_IN_TIMEBASE1.							
TB2	The internal signal IN_TIMEBASE2.							
UI2_TC	The internal analog output signal UI2_TC.							



Note *When the analog trigger circuit is enabled, the analog trigger signal takes over the PFI0 slot in the PFI selectors.*

4.8.10 Error Detection

The GPCT counters can operate in buffered mode, where the software must intervene at regular intervals to sustain the operation. Buffered mode requires real-time operation response from the software. For example, in a buffered period-measurement function, the software must be able to read the current period measurement before the hardware acquires the next period measurement. Error-detection circuits flag the case in which the software is unable to service the hardware within the allowed time. Error bits in the status register indicate the current error conditions.

4.8.10.1 Gate Acknowledge Latency Error

The gate acknowledge latency error indicates that the software does not read the HW save register in time or reads it at an inappropriate time. In several functions (for example, buffered event counting and buffered period measurement) the G_GATE signal saves the counter value in the HW save register. If the software read from the HW save register does not occur before another save operation is attempted via the G_GATE signal, the gate acknowledge latency error (*Gi_Gate_Error_St*) is set because the read value may be erroneous. The error mechanism is conservative so that an error may be present without an actual failure, but the absence of an error guarantees that no failure has occurred.

4.8.10.2 Stale Data Error

This error indicates that the G_GATE signal is not being measured properly. In several functions (for example, single pulsewidth measurement and single-period measurement) the counter uses the G_SOURCE pulses to count the duration of an event on the G_GATE signal. If two relevant G_GATE edges occur without an intervening G_SOURCE edge, then the stale data error (*Gi_Stale_Data_St*) is set because the G_GATE event was too quick to be measured by the G_SOURCE timebase.

4.8.10.3 Permanent Stale Data Error

The permanent stale data error indicates that the G_GATE signal was not measured properly at some point in a sequence of measurements. In several functions (for example, buffered pulsewidth measurement and buffered-period measurement) the counter uses the G_SOURCE pulses to count the duration of a repetitive event on the G_GATE signal. The stale data error indicates an error at a particular G_GATE edge, but may be cleared later, while the permanent stale data error detects this situation. If the stale data error is set at any point in a repetitive measurement, then the permanent stale data error (*Gi_Permanent_Stale_Data_St*) is set to indicate that a measurement error occurred at some point in the sequence.

4.8.10.4 TC Latency Error

This error indicates that some programming action related to the TC was not performed in time. In several functions (for example, buffered pulse-train generation with software programming) the software performs some action on the counter while the counter is running, and the action must complete before the counter TC is reached. If the counter TC is reached before the software is able to confirm the programming (see `Gi_TC_Interrupt_Ack`), then the TC latency error is set.

4.8.11 Detailed Operation by Application

This section discusses the detailed operation of the counter for the GPCT applications. Each description begins with a summary of how you program the counter to implement the application. A short paragraph then describes the operation of the internal signals. Finally, a figure shows the explicit relationship between applied signals and internal signals for the application.

The `G_SOURCE` signal is generated differently depending on whether you select internal timing or external timing. When you select internal timing, `G_SOURCE` is simply the internal source clock. When you select external timing, the active edge of the external source generates both edges of `G_SOURCE`—first, the falling edge, then the rising edge. A delay gate determines the width of the `G_SOURCE` negative pulse. Figure 4-31 shows the relationship between `G_SOURCE` and the source clock for internal and external timing.

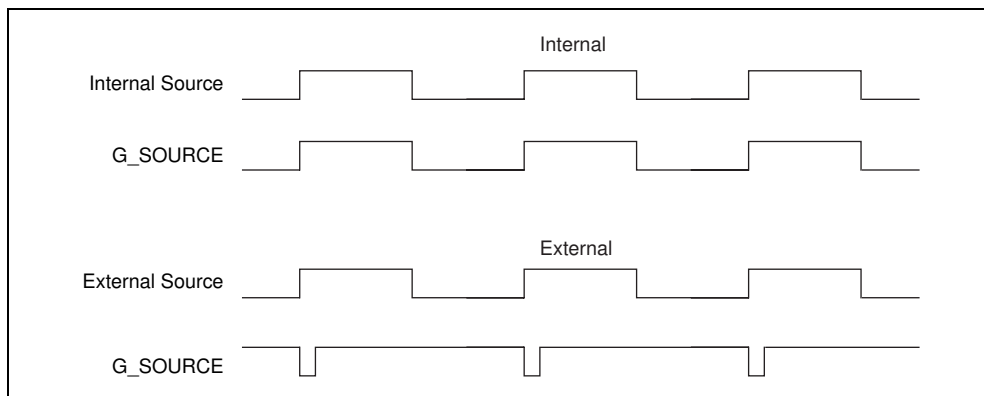

Figure 4-31. `G_SOURCE` Generation

4.8.11.1 Simple Event Counting

In simple event counting, the counter increments on every `G_SOURCE` rising edge following the ARM. To read the counter contents, use the save register.

Figure 4-32 shows an example of simple event counting where the counter counts four events on G_SOURCE. The dotted line indicates where the ARM occurs.

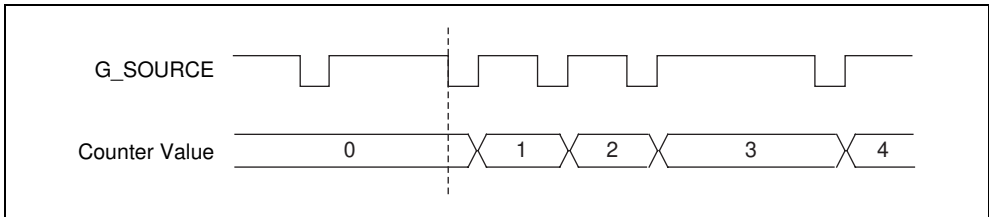

Figure 4-32. Simple Event Counting

4.8.11.2 Simple Gated-Event Counting

To use this function, set G_CONTROL conditioning to level gating and program the counter to count on G_CONTROL. G_GATE is synchronized by the falling edge of G_SOURCE to generate G_CONTROL. The counter increments only when G_CONTROL is high. The HW save register switches to transparent mode on the falling edge of G_GATE and returns to latched mode on the next G_SOURCE falling edge.

Figure 4-33 shows an example of simple gated-event counting where the gate action allows the counter to count only four of the rising edges of G_SOURCE. The HW save register latches the counter value each time the counting stops. The dotted line indicates where the ARM occurs and the arrow indicates where the gate interrupt is generated.

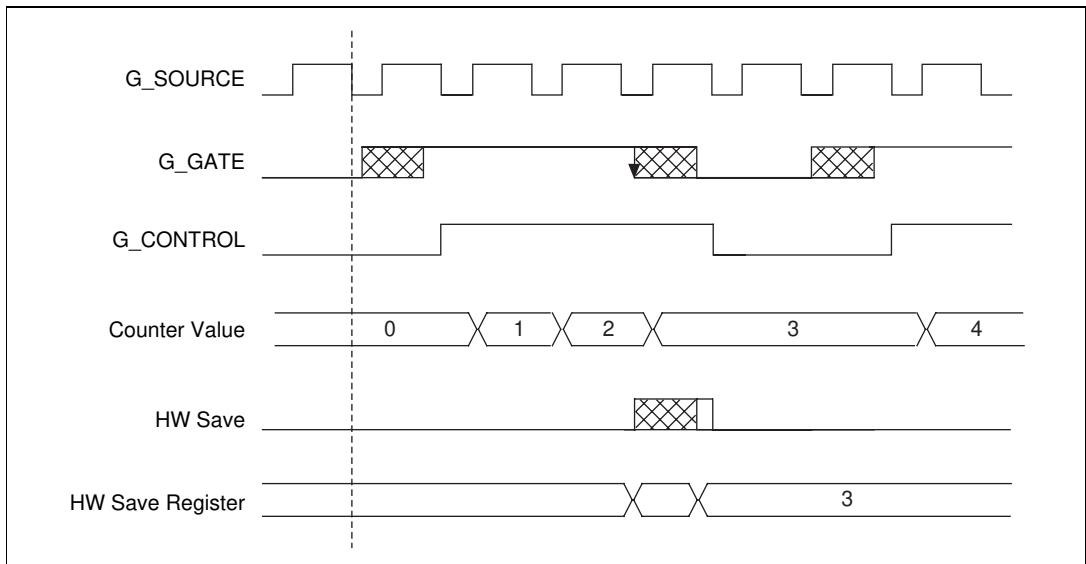

Figure 4-33. Simple Gated-Event Counting

4.8.11.3 Buffered Noncumulative-Event Counting

To use this function, set G_CONTROL conditioning to edge gating and program the counter to reload on G_CONTROL and generate interrupts on G_GATE. The rising edge of G_GATE is synchronized by the falling edge of G_SOURCE to generate a G_CONTROL pulse. The counter increments on every G_SOURCE rising edge following the ARM. On the G_SOURCE rising edge following G_CONTROL, the counter reloads from the selected load register. The HW save register switches to transparent mode on the rising edge of G_GATE and returns to latched mode on the next G_SOURCE falling edge.

Figure 4-34 shows an example of buffered noncumulative-event counting. The dotted line indicates where the ARM occurs and the arrows indicate where the gate interrupt is generated.

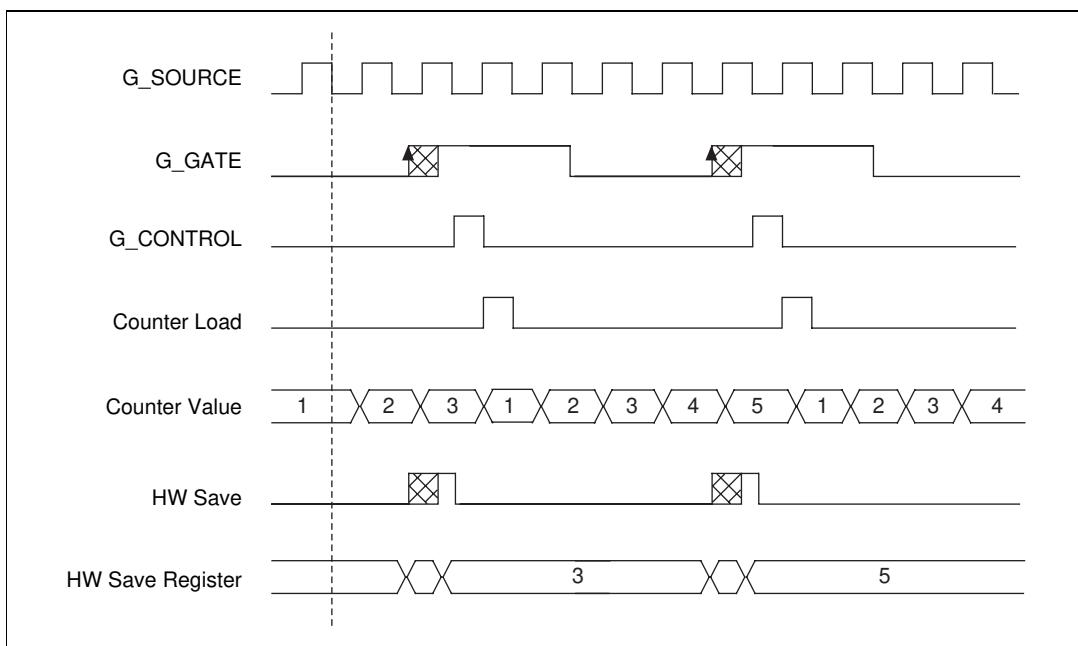

Figure 4-34. Buffered Noncumulative-Event Counting

4.8.11.4 Buffered Cumulative-Event Counting

To use this function, set G_CONTROL conditioning to edge gating and program the counter to generate interrupts on G_GATE. The counter increments on every G_SOURCE rising edge following the ARM. The HW save register switches to transparent mode on the rising edge of G_GATE and returns to latched mode on the next G_SOURCE falling edge.

Figure 4-35 shows an example of buffered cumulative-event counting. The dotted line indicates where the ARM occurs and the arrows indicate where the gate interrupt is generated.

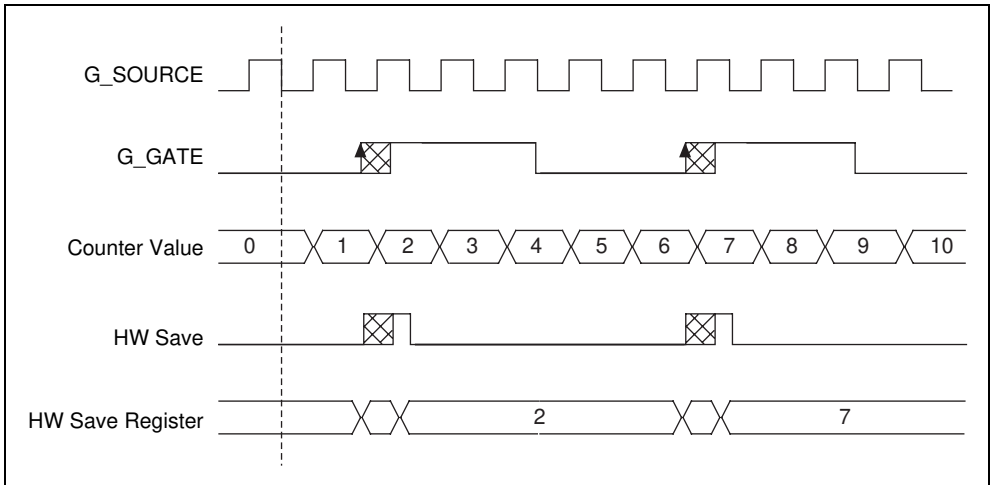

Figure 4-35. Buffered Cumulative-Event Counting

4.8.11.5 Relative-Position Sensing

To use this function, program the counter to use G_UP_DOWN as an up/down control. G_UP_DOWN is synchronized by the falling edge of G_SOURCE to generate the up/down control signal. After the ARM, the counter increments when up/down is high and decrements when up/down is low.

Figure 4-36 shows an example of relative-position sensing. The dotted line indicates where the ARM occurs.

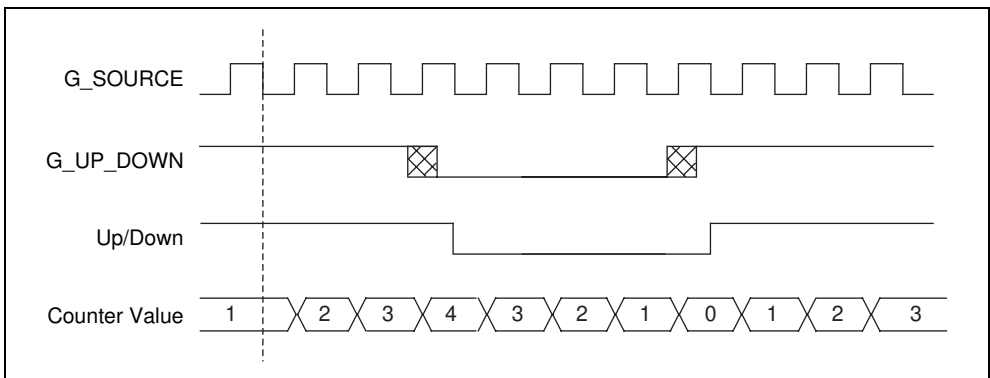

Figure 4-36. Relative-Position Sensing

4.8.11.6 Single-Period Measurement

To use this function, set G_CONTROL conditioning to edge gating and program the counter to count once. The rising edge of G_GATE is synchronized by the falling edge of G_SOURCE to generate a G_CONTROL pulse. The counter increments on every G_SOURCE rising edge following the G_CONTROL pulse. On the second G_CONTROL pulse, the counter disarms. The HW save register switches to transparent mode on the rising edge of G_GATE and returns to latched mode on the next G_SOURCE falling edge.

Figure 4-37 shows an example of a single-period measurement where the period of G_GATE is five G_SOURCE rising edges. The dotted line indicates where the ARM occurs and the arrows indicate where the gate interrupt is generated.

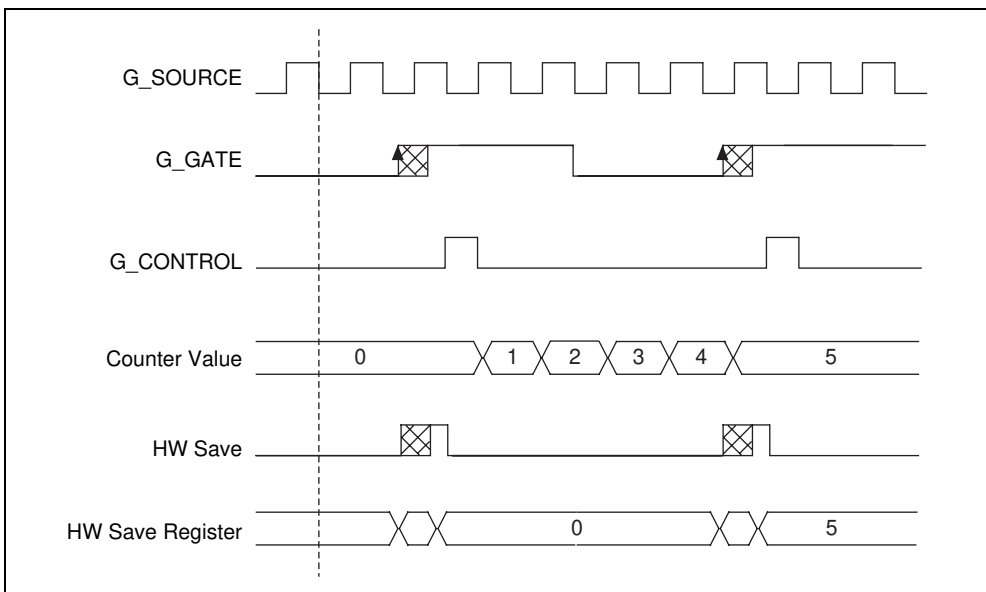

Figure 4-37. Single-Period Measurement

4.8.11.7 Single Pulsewidth Measurement

To use this function, set G_CONTROL conditioning to level gating and program the counter to START on G_CONTROL and count once. G_GATE is synchronized by the falling edge of G_SOURCE to generate G_CONTROL. The counter begins incrementing when G_CONTROL is sensed high. The counter disarms when G_CONTROL returns low. The HW save register switches to transparent mode on the rising edge of G_GATE and returns to latched mode on the next G_SOURCE falling edge. Interrupts, if enabled, are generated on the G_GATE falling edge.

Figure 4-38 shows an example of a single pulsewidth measurement where the pulsewidth of G_GATE is four G_SOURCE rising edges. The dotted line indicates where the ARM occurs and the arrows indicate where the gate interrupt is generated. Figure 4-38 assumes that ARM occurs while G_GATE is low. If ARM occurs while G_GATE is high, the G_GATE pulse will only be measured from ARM until the end of the pulse.

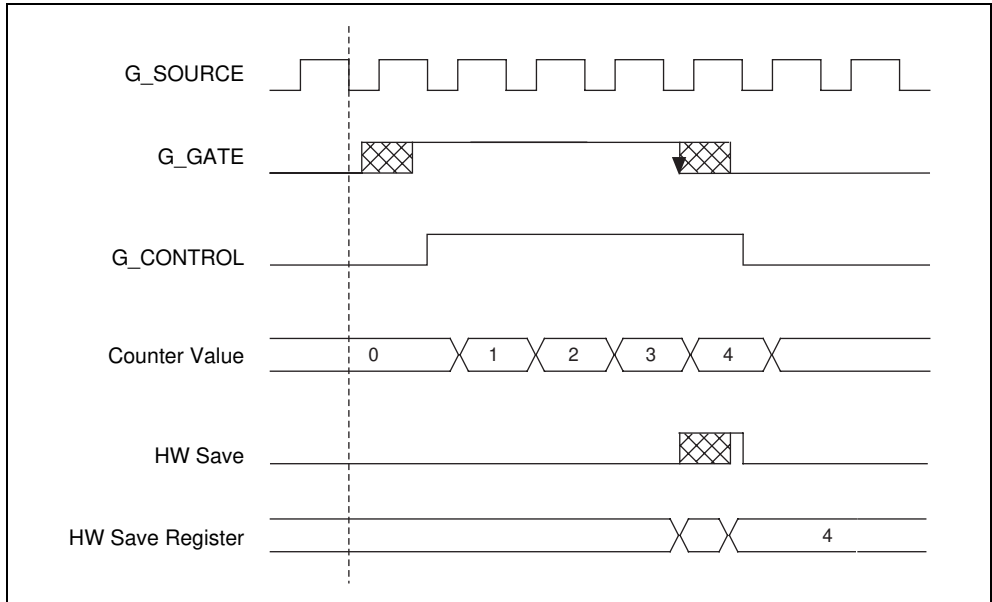

Figure 4-38. Single Pulsewidth Measurement

4.8.11.8 Buffered Period Measurement

To use this function, set G_CONTROL conditioning to edge gating and program the counter to reload on G_CONTROL and generate interrupts on G_GATE. The counter increments on every G_SOURCE rising edge following the ARM. The rising edge of G_GATE is synchronized by the falling edge of G_SOURCE to generate a G_CONTROL pulse. On the G_SOURCE rising edge following each G_CONTROL pulse, the counter reloads from the selected load register. The HW save register switches to transparent mode on the rising edge of G_GATE and returns to latched mode on the next G_SOURCE falling edge.

Figure 4-39 shows an example of a buffered period measurement where the period is five G_SOURCE rising edges. The dotted line indicates where the ARM occurs and the arrows indicate where the gate interrupt is generated.

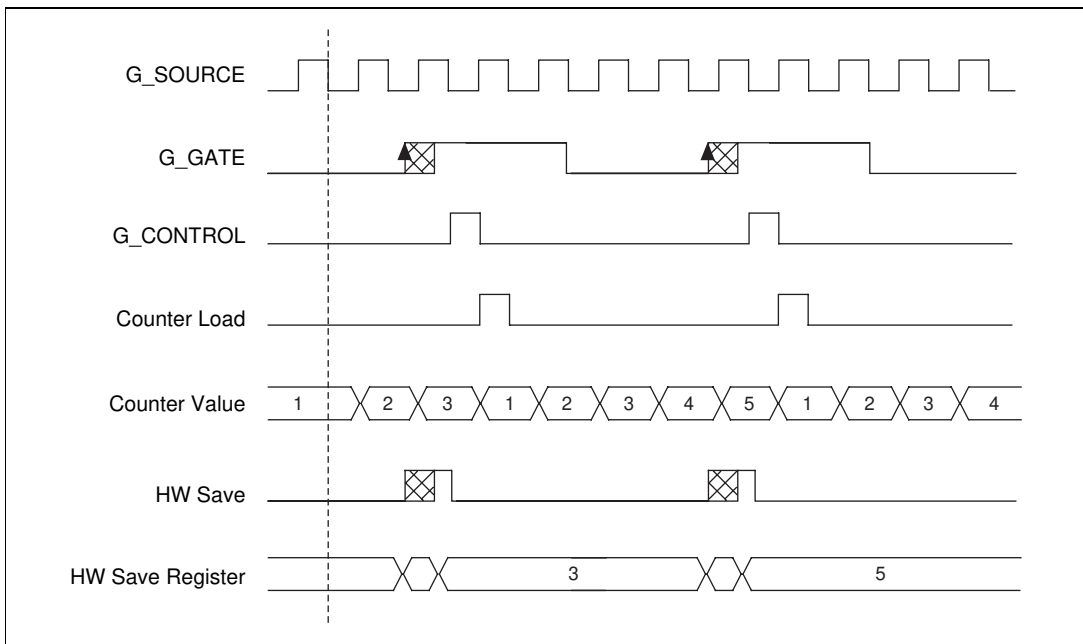

Figure 4-39. Buffered Period Measurement

4.8.11.9 Buffered Semiperiod Measurement

To use this function, set G_CONTROL conditioning to edge gating (double edge) and program the counter to reload on G_CONTROL and generate interrupts on G_GATE. The counter increments on every G_SOURCE rising edge following the ARM. Every G_GATE transition is synchronized by the falling edge of G_SOURCE to generate a G_CONTROL pulse. On the G_SOURCE rising edge following G_CONTROL, the counter reloads from the selected load register. The HW save register switches to transparent mode on every edge of G_GATE and returns to latched mode on the next G_SOURCE falling edge.

Figure 4-40 shows an example of buffered semiperiod measurement where the first semiperiod is four G_SOURCE rising edges and the second semiperiod is three G_SOURCE rising edges. The dotted line indicates where the ARM occurs and the arrows indicate where the gate interrupt is generated.

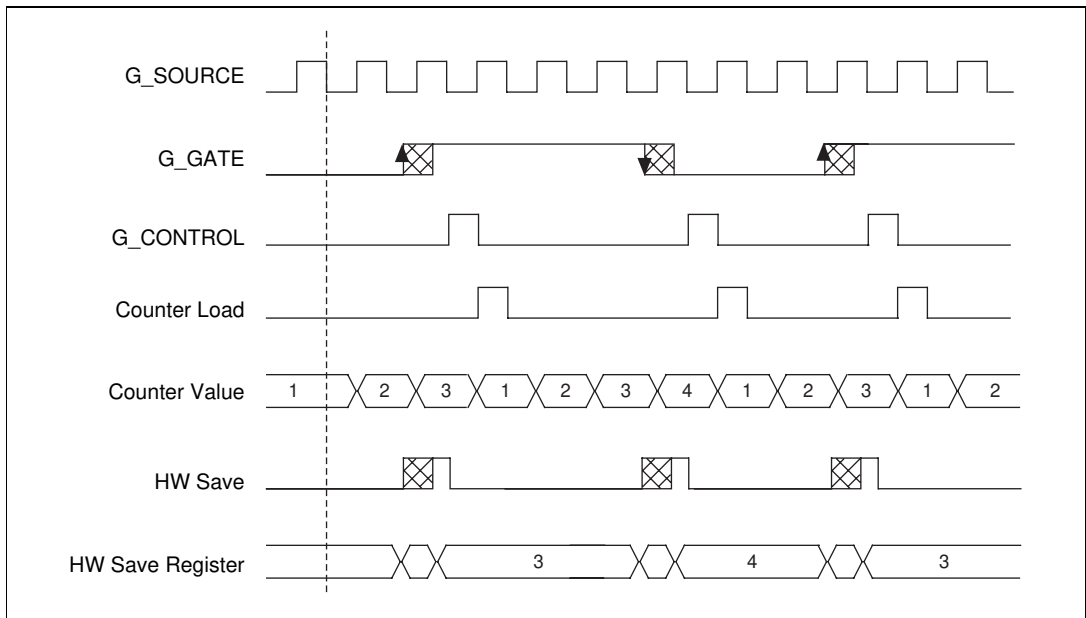

Figure 4-40. Buffered Semiperiod Measurement

4.8.11.10 Buffered Pulsewidth Measurement

To use this function, set G_CONTROL conditioning to level gating and program the counter to reload on G_CONTROL and generate interrupts on G_GATE. The counter increments on every G_SOURCE rising edge following the ARM. G_GATE is synchronized by the falling edge of G_SOURCE to generate G_CONTROL. On the G_SOURCE rising edge following G_CONTROL, the counter reloads from the selected load register. The HW save register switches to transparent mode on the falling edge of G_GATE and returns to latched mode on the next G_SOURCE falling edge.

Figure 4-41 show an example of buffered pulsewidth measurement where the pulsewidth is three G_SOURCE rising edges. The dotted line indicates where the ARM occurs and the arrows indicate where the gate interrupt is generated. Figure 4-41 assumes that ARM occurs while G_GATE is low. If ARM occurs while G_GATE is high, the initial pulse will only be measured from ARM until the end of the pulse.

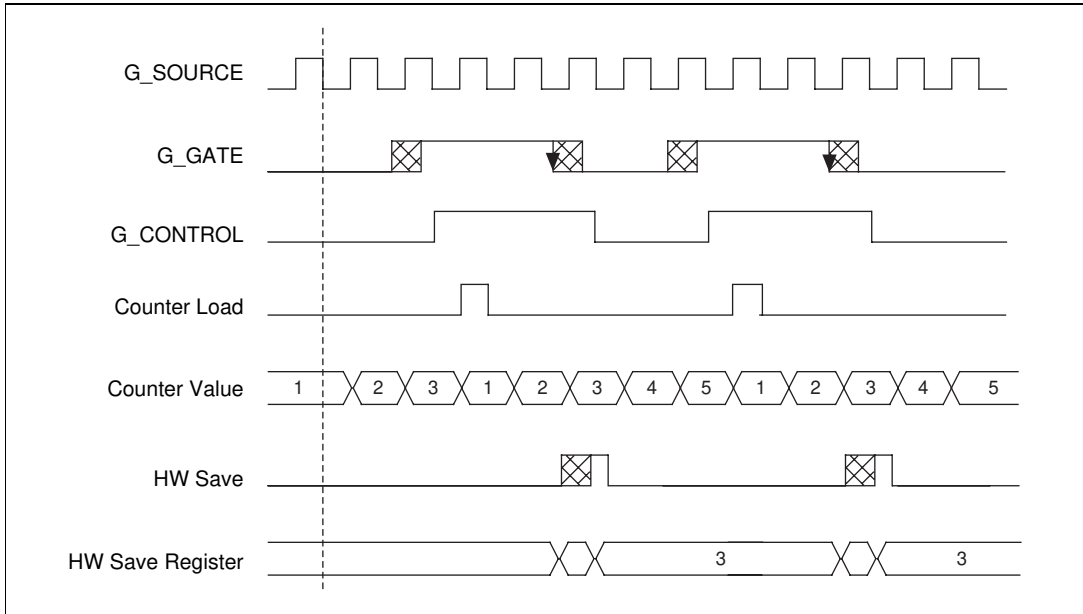

Figure 4-41. Buffered Pulsewidth Measurement

4.8.11.11 Single Pulse Generation

To use this function, program the counter to reload on TC, stop at the second TC, and count once. The counter begins decrementing after the ARM. Once the counter TC is reached, the counter reloads and counts down to TC again. On the second counter TC, the counter disarms. The load-select signal indicates whether the reload occurs from load register A or B.

Figure 4-42 shows an example of single pulse generation with a pulse delay of five and a pulsewidth of three. The dotted line indicates where the ARM occurs.

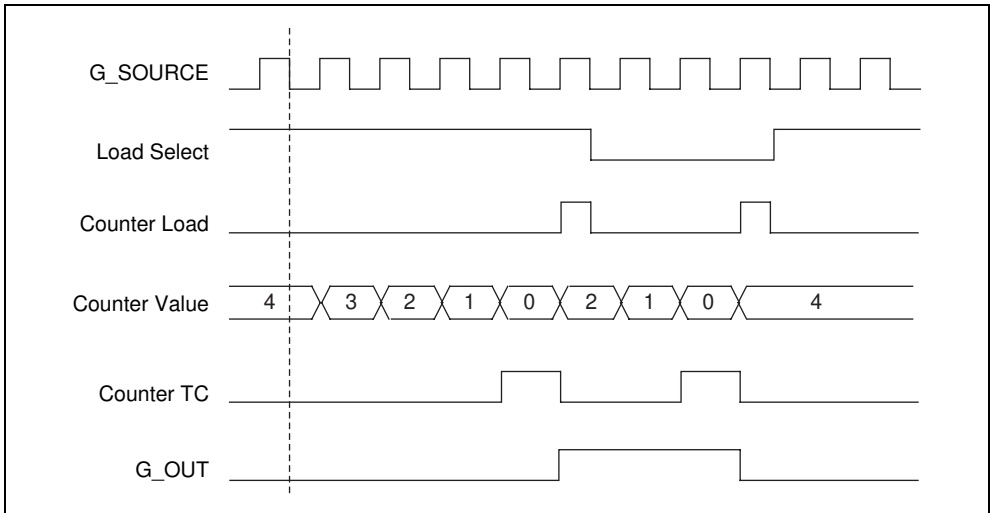

Figure 4-42. Single Pulse Generation

4.8.11.12 Single-Triggered Pulse Generation

To use this function, set G_CONTROL conditioning to edge gating and program the counter to reload on TC, stop at the second TC, and count once. The rising edge of G_GATE is synchronized by the falling edge of G_SOURCE to generate a G_CONTROL pulse. The counter begins decrementing after the G_CONTROL pulse. Once the counter TC is reached, the counter reloads and counts down to TC again. On the second counter TC, the counter disarms. The load-select signal indicates whether the reload occurs from load register A or B.

Figure 4-43 shows an example of single-triggered pulse generation with a pulse delay of five and a pulsewidth of three. The dotted line indicates where the ARM occurs.

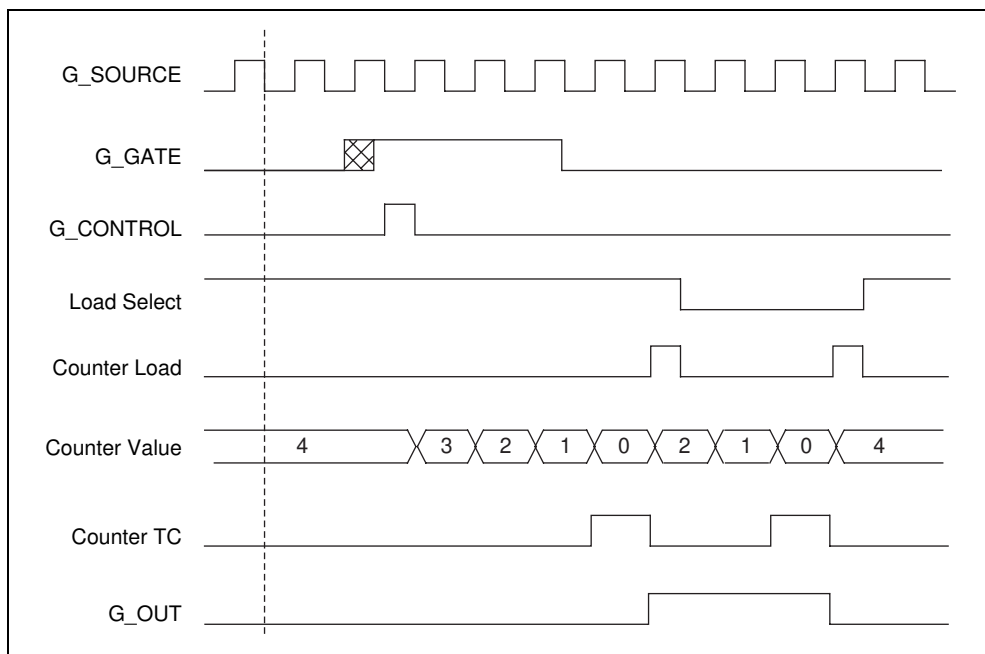

Figure 4-43. Single-Triggered Pulse Generation

4.8.11.13 Retriggerable Single Pulse Generation

To use this function, set G_CONTROL conditioning to edge gating and program the counter to reload on TC and stop at the second TC. The rising edge of G_GATE is synchronized by the falling edge of G_SOURCE to generate a G_CONTROL pulse. The counter begins decrementing after the G_CONTROL pulse. Once the counter TC is reached, the counter reloads and counts down to TC again. On the second counter TC, the counter stops to wait for another gate. On the next G_GATE rising edge, the whole process begins again. The load-select signal indicates whether the reload occurs from load register A or B. The dotted line indicates where the ARM occurs.

Figure 4-44 shows an example of retriggerable single pulse generation with a pulse delay of four and a pulsewidth of two. The dotted line indicates where the ARM occurs.

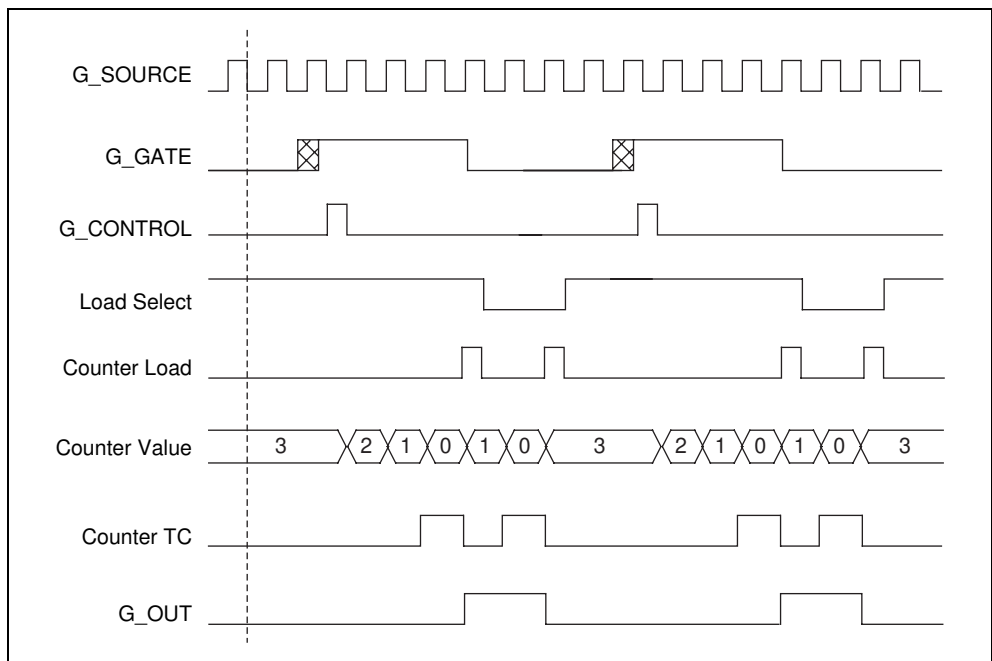

Figure 4-44. Retriggerable Single Pulse Generation

4.8.11.14 Continuous Pulse-Train Generation

To use this function, set G_CONTROL conditioning to edge gating and program the counter to reload on TC. The rising edge of G_GATE is synchronized by the falling edge of G_SOURCE to generate a G_CONTROL pulse. The counter begins decrementing after the G_CONTROL pulse. Whenever counter TC is reached, the counter reloads and counts down to TC again. The load-select signal indicates whether the reload occurs from load register A or B.

Figure 4-45 shows an example of continuous pulse-train generation with a pulse interval of four and a pulsewidth of three. The dotted line indicates where the ARM occurs.

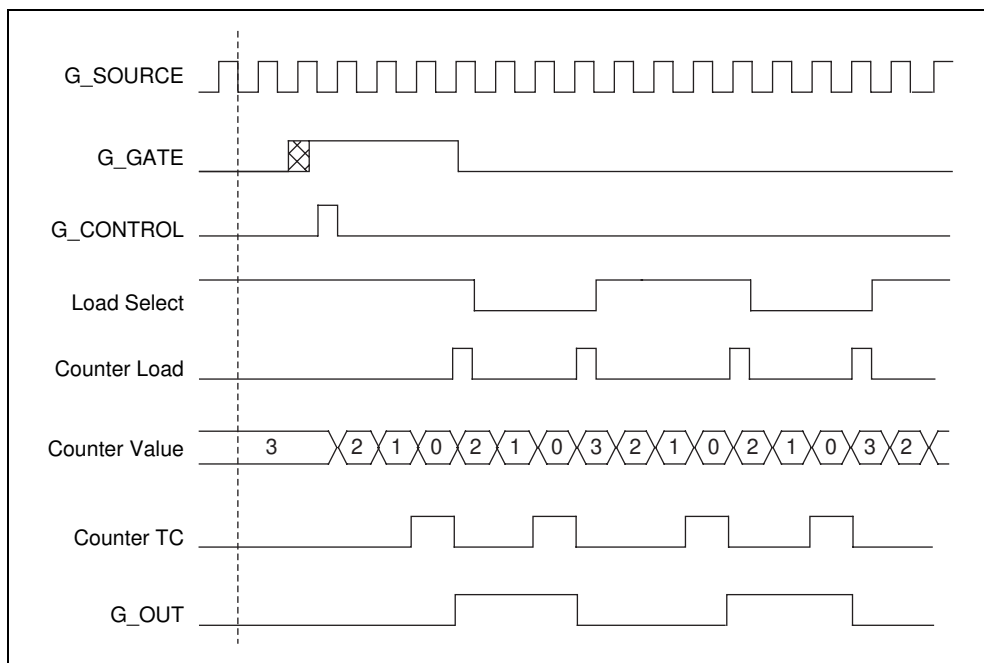

Figure 4-45. Continuous Pulse-Train Generation

4.8.11.15 Buffered Pulse-Train Generation

To use this function, set G_CONTROL conditioning to edge gating and program the counter to reload on TC and generate interrupts on TC. The rising edge of G_GATE is synchronized by the falling edge of G_SOURCE to generate a G_CONTROL pulse. The counter begins decrementing after the G_CONTROL pulse. Whenever counter TC is reached, the counter reloads and counts down to TC again. The load-select signal indicates whether the reload occurs from load register A or B. After every second counter TC, the interrupt service routine programs the counter to switch load register banks. The bank-select signal then changes on the falling edge of the next counter TC.

Figure 4-46 shows an example of a buffered pulse-train generation. The first pulse has a delay from trigger of two, a pulsewidth of five, and a pulse interval of four. The second pulse has a pulsewidth of three and a pulse interval of two. The interrupt software programs the counter to switch load register banks at the second and fourth TC interrupts. The dotted line indicates where the ARM occurs and the arrows indicate where the TC interrupt is generated.

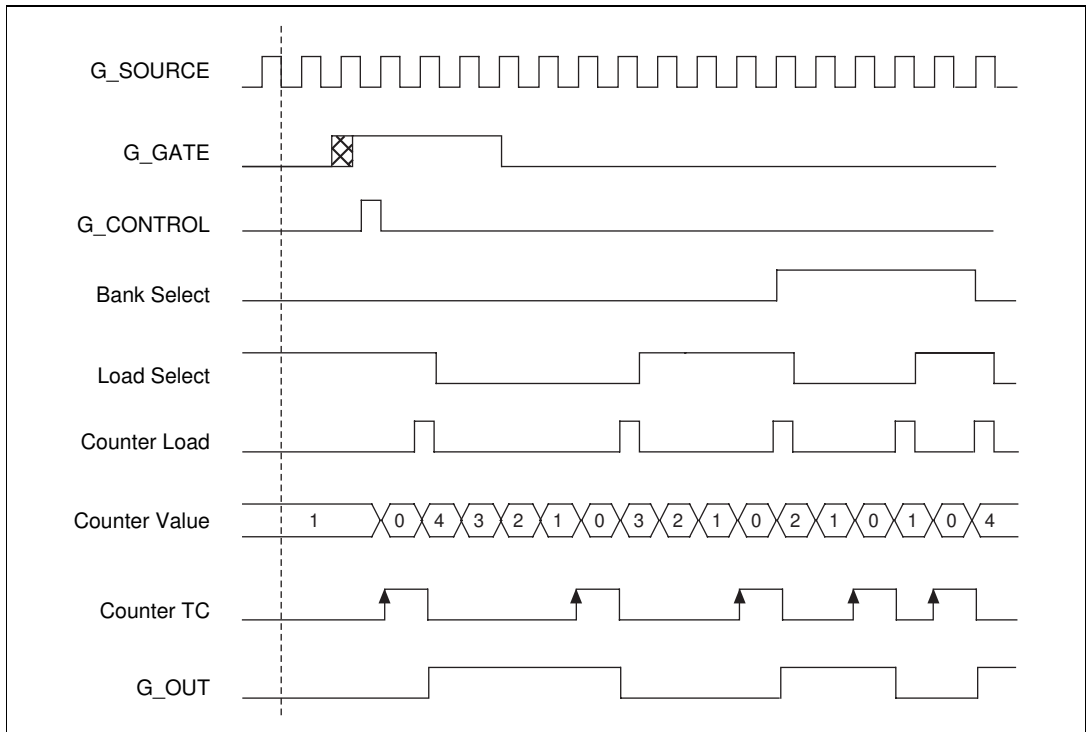

Figure 4-46. Buffered Pulse-Train Generation

4.8.11.16 Frequency Shift Keying

To use this function, set G_CONTROL conditioning to level gating and program the counter to reload on TC and switch the load bank selection on G_CONTROL. The counter begins decrementing after the ARM. Whenever counter TC is reached, the counter reloads and counts down to TC again. G_GATE is synchronized by the falling edge of G_SOURCE to generate G_CONTROL. G_CONTROL affects the bank-select signal, which indicates whether the reload occurs from bank X or Y. The load-select signal indicates whether the reload occurs from load register A or B.

Figure 4-47 shows an example of frequency shift keying. When G_GATE is low, pulses are generated with a pulse interval of three and a pulsewidth of two. When G_GATE is high, pulses are generated with a pulse interval of five and a pulsewidth of four. The dotted line indicates where the ARM occurs.

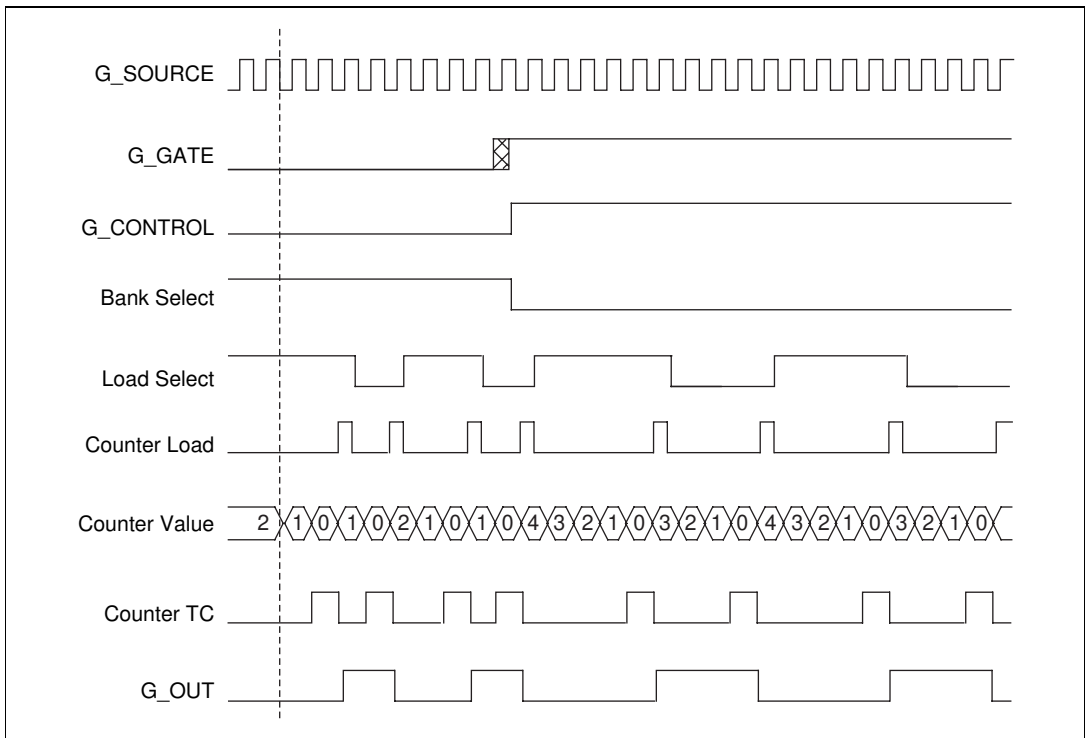

Figure 4-47. Frequency Shift Keying

4.8.11.17 Pulse Generation for ETS

To use this function, set G_CONTROL conditioning to edge gating, program the counter to reload on TC and stop at the second TC, and program load register A to autoincrement after every reload. The rising edge of G_GATE is synchronized by the falling edge of G_SOURCE to generate a G_CONTROL pulse. The counter begins decrementing after the G_CONTROL pulse. Once the counter TC is reached, the counter reloads and counts down to TC again. On the second counter TC, the counter stops to wait for another gate. On the next G_GATE rising edge, the whole process begins again. The load-select signal indicates whether the reload occurs from load register A or B. Each time the counter reloads from load register A, the value in load register A increments by a fixed amount.

Figure 4-48 shows an example of pulse generation for ETS with an initial pulse delay of three and a pulsewidth of two. The pulse delay for each subsequent pulse is one larger than the pulse delay of the previous pulse. The dotted line indicates where the ARM occurs.

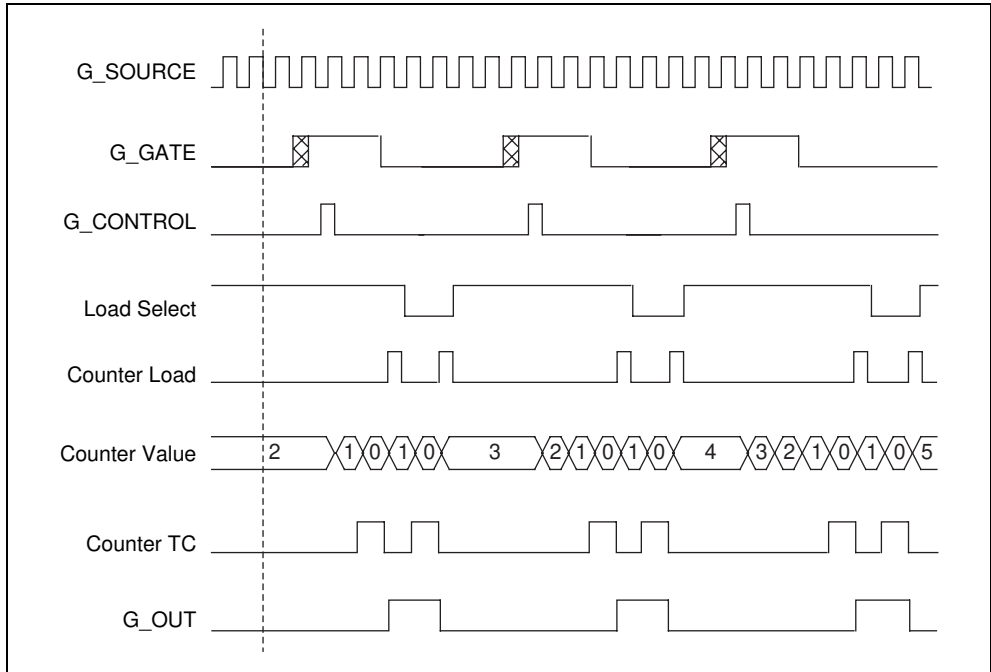

Figure 4-48. Pulse Generation for ETS

Programmable Function Inputs

5.1 Overview

This chapter explains the PFI module on the DAQ-STC. The 10 PFI lines provide a user configurable interface to the board I/O connector. External timing, trigger, and control signals can be input through the PFI and routed internally within the DAQ-STC. Also, the PFI lines can output internally generated timing, trigger, and control signals on dedicated pins when the pins are not used as inputs.

5.2 Features

The PFI module has the following features:

- Ten individually programmable bidirectional lines
- 9 mA sink current, 5 mA source current
- Analog input timing module interface
 - Inputs: START1, START2, START, STOP, SI source, CONVERT source, and external gate
 - Outputs: START1, START2, START, CONVERT, and SCAN_IN_PROG
- Analog output timing module interface
 - Inputs: START1, START, UPDATE, UI source, UI2 source, and secondary external gate
 - Outputs: START1 and UPDATE
- General-purpose counter/timer interface
 - Inputs: G0 source, G0 gate, G1 source, and G1 gate
 - Outputs: G0 source, G0 gate, G1 source, and G1 gate

5.3 Pin Interface

The 10 PFI signals are listed in the following table. An asterisk following a pin name indicates that the default polarity for that pin is active low.

Pin Type Notation:

B9TU

Bidirectional, 9 mA sink, 5 mA source tri-state, pull up (50 k Ω)

Table 5-1. Pin Interface

Pin Name	Type	Description
PFI0/AI_START1	B9TU	<p>PFI0/START1 Trigger from Analog Input—As an input, this pin provides a signal path to the PFI selectors. As an output, this pin reflects the state of the active high internal AI START1 signal. The hardware generates PFI0/AI_START1 as follows:</p> <ul style="list-style-type: none"> • If AI_Trigger_Length is 0, this pin reflects the internal AI signal ADR_START1. • If AI_Trigger_Length is 1, this pin reflects the internal AI signal AD_START1 after it has been pulse stretched to be 1–2 AI_OUT_TIMEBASE periods long. <p>Source/Destination: This pin is appropriate for use as a bidirectional EXTTRIG signal. Related bitfields: BD_0_Pin_Dir, AI_Trigger_Length, Analog_Trigger_Enable.</p>
PFI1/AI_START2	B9TU	<p>PFI1/START2 Trigger from Analog Input—As an input, this pin provides a signal path to the PFI selectors. As an output, this pin reflects the state of the active high internal AI START2 signal. The hardware generates PFI1/AI_START2 as follows:</p> <ul style="list-style-type: none"> • If AI_Trigger_Length is 0, this pin reflects the internal AI signal ADR_START2. • If AI_Trigger_Length is 1, this pin reflects the internal AI signal AD_VSTART2 after it has been pulse stretched to be 1–2 AI_OUT_TIMEBASE periods long. <p>Source/Destination: This pin is appropriate for use as a bidirectional PRETRIG signal. Related bitfields: BD_1_Pin_Dir, AI_Trigger_Length.</p>

Table 5-1. Pin Interface (Continued)

Pin Name	Type	Description
PFI2/CONV*	B9TU	PFI2/ADC Conversion Strobe from Analog Input—As an input, this pin provides a signal path to the PFI selectors. As an output, this reflects the internal AI signal SCLKG, the signal that appears on the CONVERT pin. The hardware generates SCLKG by passing the internal AI signal SCLK through pulsewidth and polarity selection circuitry. Source/Destination: This pin is appropriate for use as a bidirectional EXTCONV* signal. Related bitfields: BD_2_Pin_Dir, AI_CONVERT_Output_Select.
PFI3/G_SRC1	B9TU	PFI3/General-Purpose Counter 1 Source—As an input, this pin provides a signal path to the PFI selectors. As an output, this pin reflects the internal signal G_SOURCE from general-purpose counter 1. Source/Destination: This pin is appropriate for use as a bidirectional CTRSRC1 signal. Related bitfields: BD_3_Pin_Dir.
PFI4/G_GATE1	B9TU	PFI4/General-Purpose Counter 1 Gate—As an input, this pin provides a signal path to the PFI selectors. As an output, this pin reflects the internal signal G_GATE from general-purpose counter 1. Source/Destination: This pin is appropriate for use as a bidirectional CTRGATE1 signal. Related bitfields: BD_4_Pin_Dir.
PFI5/UPDATE*	B9TU	PFI5/Primary Update from Analog Output—As an input, this pin provides a signal path to the PFI selectors. As an output, this pin reflects the internal AO signal DACUPDN (the update signal from the analog output section). Source/Destination: This pin is appropriate for use as a bidirectional EXTDACUPDATE* signal. Related bitfields: BD_5_Pin_Dir.

Table 5-1. Pin Interface (Continued)

Pin Name	Type	Description
PFI6/AO_START1	B9TU	<p>PFI6/START1 Trigger from Analog Output—As an input, this pin provides a signal path to the PFI selectors. As an output, this pin reflects the state of the active high internal AO signal START1. The hardware generates PFI6/AO_START1 as follows:</p> <ul style="list-style-type: none"> • If AO_Trigger_Length is 0, this pin reflects the internal AO signal DA_START1. • If AO_Trigger_Length is 1, this pin reflects the internal AO signal DA_ST1ED after it has been pulse stretched to be 1–2 AO_OUT_TIMEBASE periods long. <p>Source/Destination: This pin is appropriate for use as a bidirectional EXTWFTRIG signal. Related bitfields: BD_6_Pin_Dir, AO_Trigger_Length.</p>
PFI7/AI_START	B9TU	<p>PFI7/START Trigger from Analog Input—As an input, this pin provides a signal path to the PFI selectors. As an output, this pin can reflect the state of the active high internal AI signal START or it can output the polarity selectable SCAN_IN_PROG signal from the AITM section. If AI_START_Output_Select is 0, the hardware generates PFI7/AI_START as follows:</p> <ul style="list-style-type: none"> • If AI_Trigger_Length is 0, this pin reflects the internal AI signal AD_START. • If AI_Trigger_Length is 1, this pin reflects the internal AI signal AD_START after it has been pulse stretched to be 1–2 AI_OUT_TIMEBASE periods long. <p>If AI_START_Output_Select is 1, PFI7/AI_START will output the same signal as SCAN_IN_PROG. If SCAN_IN_PROG is configured for high impedance, PFI7/AI_START will output ground. Source/Destination: This pin is appropriate to input an EXTGATE from the I/O connector. Related bitfields: BD_7_Pin_Dir, AI_START_Output_Select, AI_Trigger_Length, AI_SCAN_IN_PROG_Output_Select.</p>

Table 5-1. Pin Interface (Continued)

Pin Name	Type	Description
PFI8/G_SRC0	B9TU	PFI8/General-Purpose Counter 0 Source—As an input, this pin provides a signal path to the PFI selectors. As an output, this pin reflects the internal signal G_SOURCE from general-purpose counter 0. Source/Destination: This pin is appropriate for use as a bidirectional CTRSRC0 signal. Related bitfields: BD_8_Pin_Dir.
PFI9/G_GATE0	B9TU	PFI9/General-Purpose Counter 0 Gate—As an input, this pin provides a signal path to the PFI selectors. As an output, this pin reflects the internal signal G_GATE from general-purpose counter 0. Source/Destination: This pin is appropriate for use as a bidirectional CTRGATE0 signal. Related bitfields: BD_9_Pin_Dir.

5.4 Programming Information

This section presents programming information that is specific to the PFIs. For general information about programming the DAQ-STC, see section 2.6, *Programming Information*.

5.4.1 Programming the PFI Pins

This section contains detailed programming information for bit-level programming of the PFI pins for specialized applications.

The DAQ-STC has 10 bidirectional pins for user signals. If a pin is programmed for input, the PFI reflects the state of the external signal connected to the pin. If a pin is programmed for output, the PFI reflects the state of the internally generated signal that drives the pin. The PFIs are commonly available for signal selection.

Use this function to configure the direction of one of the 10 PFI pins.

```
Function MSC_IO_Pin_Configure
{
    switch (pin number)
    {
        case 0:
            BD_0_Pin_Dir = 0 (input) or 1 (output);
            break;
        case 1:
            BD_1_Pin_Dir = 0 (input) or 1 (output);
            break;
    }
}
```

```

case 2:
    BD_2_Pin_Dir = 0 (input) or 1 (output);
    break;
case 3:
    BD_3_Pin_Dir = 0 (input) or 1 (output);
    break;
case 4:
    BD_4_Pin_Dir = 0 (input) or 1 (output);
    break;
case 5:
    BD_5_Pin_Dir = 0 (input) or 1 (output);
    break;
case 6:
    BD_6_Pin_Dir = 0 (input) or 1 (output);
    break;
case 7:
    BD_7_Pin_Dir = 0 (input) or 1 (output);
    If (BD_7_Pin_Dir is 1) then
        AI_START_Output_Select = 0 (output AD START) or
        1 (output AD SCAN_IN_PROG);
    break;
case 8:
    BD_8_Pin_Dir = 0 (input) or 1 (output);
    break;
case 9:
    BD_9_Pin_Dir = 0 (input) or 1 (output);
    break;
}
}

```



Warning *You must be very careful when programming bidirectional pins for output. If an external signal is driving a bidirectional pin and you configure the pin for output, you may cause physical damage to the DAQ-STC, the external circuitry, or both.*

5.4.2 Bitfield Descriptions

Bits in the register bit maps are organized into bitfields. A bitfield can contain one or more bits. Only bits with contiguous locations within a register can belong to a bitfield. The high and low pairs of load and save registers for 24-bit counters are also treated as bitfields. The PFI-related bitfields are described below. Not all bitfields referred to in section 5.4, *Programming Information*, are listed here. To locate a particular bitfield description within this manual, refer to Appendix B, *Register Information*.

BD_i_Pin_Dir

$i = 0-9$ **bit:** i **type:** Write **in:** IO_Bidirection_Pin_Register **address:** 57

This bit selects the direction of the bidirectional pin, PFI i :

- 0: Input.
- 1: Output.

5.5 Detailed Description

When configured as inputs, the PFI<0..9> pins provide an interface through which your timing I/O signals can be brought to the internal DAQ-STC modules. Each of the three main internal modules—AITM, AOTM, and GPCT—has 20-to-1 input multiplexers (PFI selectors) to select their relevant timing/control input signals. Two of the inputs to the PFI selectors are generally used by internal signal sources such as software strobes and internal timebases. The remaining available inputs are used for 17 timing I/O pins—10 PFI pins and seven RTSI_TRIGGER pins. Table 5-2 indicates the input selections available for each of the PFI multiplexers.

Table 5-2. PFI<0..9> Input Selections

Mux	0	1-10	11-17	18	19	20	21	31
AI_START1_Source	SW	PFI<0..9>	RTSI<0..6>	GOUT0				GND
AI_START2_Source	SW	PFI<0..9>	RTSI<0..6>					GND
AI_SI_Source	AI_TB1	PFI<0..9>	RTSI<0..6>		TB2			GND
AI_CONVERT_Source	SI2_TC	PFI<0..9>	RTSI<0..6>		GOUT0			GND
AI_START_Source	SI_TC	PFI<0..9>	RTSI<0..6>	SW	GOUT0			GND
AI_STOP_Source	DIV_TC, SW	PFI<0..9>	RTSI<0..6>	SI2_TC	AI_STP			GND
AI_External_Gate		PFI<0..9>	RTSI<0..6>					GND
AO_START1_Source	SW	PFI<0..9>	RTSI<0..6>		AI_ST1			GND
AO_START_Source	SW, UC_TC	PFI<0..9>	RTSI<0..6>					GND
AO_UPDATE_Source	UI_TC	PFI<0..9>	RTSI<0..6>		GOUT1			GND
AO_UI_Source	AO_TB1	PFI<0..9>	RTSI<0..6>		TB2			GND
AO_UI2_Source	AO_TB1	PFI<0..9>	RTSI<0..6>	G0_TC	G1_TC	TB2		GND
AO_UI_External_Gate		PFI<0..9>	RTSI<0..6>					GND
AO_UI2_External_Gate		PFI<0..9>	RTSI<0..6>					GND
G0_Source	G_TB1	PFI<0..9>	RTSI<0..6>	TB2	G1_TC			GND

Table 5-2. PFI<0..9> Input Selections (Continued)

Mux	0	1–10	11–17	18	19	20	21	31
G0_Gate		PFI<0..9>	RTSI<0..6>	AI_ST2	UI2_TC	GOUT1	AI_ST1	GND
G1_Source	G_TB1	PFI<0..9>	RTSI<0..6>	TB2	G0_TC			GND
G1_Gate		PFI<0..9>	RTSI<0..6>	AI_ST2	UI2_TC	GOUT0	AI_ST1	GND
Key:								
AI_STP The input AI_STOP_IN								
AI_ST1 The internal analog input signal START1								
AI_ST2 The internal analog input signal START1								
AI_TB1 The internal analog input signal AI_IN_TIMEBASE1								
AO_TB1 The internal analog output signal AO_IN_TIMEBASE1								
G0_TC The G_TC signal from general-purpose counter 0								
G1_TC The G_TC signal from general-purpose counter 1								
GOUT0 The GOUT signal from general-purpose counter 0								
GOUT1 The GOUT signal from general-purpose counter 1								
G_TB1 The internal signal G_IN_TIMEBASE1								
SW Software strobe								
TB2 The internal signal IN_TIMEBASE2								

**Note**

When the analog trigger circuit is enabled, the analog trigger signal takes over the PFI0 slot in the PFI selectors.

The PFI pins will power up as inputs and will primarily be used as inputs; however, PFI pins can also be configured as outputs. When configured as an output, each pin reflects the status of a particular signal related to the user timing signals. The output capability on these pins is useful for synchronizing external circuitry to the board. Table 5-3 indicates the internal signal that will be output on each PFI pin when the pin is configured for output. Refer to section 5.3, *Pin Interface*, for more detailed information on the internal signal tap point.

Table 5-3. PFI<0..9> Output Selections

PFI	SIGNAL
0	AI START1
1	AI START2
2	CONVERT
3	G1 Source
4	G1 Gate
5	AO UPDATE
6	AO START1

Table 5-3. PFI<0..9> Output Selections

PFI	SIGNAL
7	AI START or AI SCAN_IN_PROG
8	G0 Source
9	G0 Gate

RTSI Trigger

6.1 Overview

This chapter describes the features of the RTSI trigger module (RTM) and explains how to program the RTSI interface. The RTM eliminates the need for a RTSI ASIC on the board by providing the equivalent functionality. The RTM consists of seven 12-to-1 multiplexers that drive seven RTSI trigger bus signals and four 8-to-1 multiplexers that drive the four RTSI board signals.

Any of the seven RTSI trigger bus signals can be driven by eight internally generated timing signals and the four RTSI board signals. Similarly, the four RTSI board signals can be driven by any of the RTSI trigger bus signals.

6.2 Features

The RTM has the following features:

- RTSI ASIC (cross-bar switch) type routing capability obviates the need for a RTSI ASIC.
 - Eight internal signals can drive any of the seven RTSI trigger lines
 - RTSI trigger bus signals can drive any of the internal trigger or timing signals
 - Four additional bidirectional pins for communication between the RTSI trigger bus and board signals

6.3 Pin Interface

The RTSI signals are listed in the following table.

Pin Type Notation:

B9TU

Bidirectional, 9 mA sink, 5 mA source tri-state, pull up (50 k Ω)

Table 6-1. Pin Interface

Pin Name	Type	Description
RTSI_TRIGGER<0..6>	B9TU	RTSI Trigger—As an input, these pins are the seven RTSI trigger lines. As an output, these pins can be driven from 12 signal sources ADR_START1, ADR_START2, SCLKG, DACUPDN, DA_START1, G_SRC 0, G_GATE 0, RGOUT0, and RTSI_BRD<0..3>. Source/Destination: These pins are appropriate for use as bidirectional RTSI_TRIGGER bus signals. Related bitfields: RTSI_Trig_i_Pin_Dir, RTSI_Trig_i_Output_Select.
RTSI_BRD<0..3>	B9TU	RTSI Board Interface—Configured as an input, each bidirectional RTSI_BRD pin can drive any of the seven RTSI_TRIGGER pins. RTSI_BRD<0..1> can also be driven by AI_STOP and RTSI_BRD<2..3> can also be driven by the AI_START and SCAN_IN_PROG signals. These pins provide a mechanism for additional board-level signals to be sent on or received from the RTSI bus. Related bitfields: RTSI_Board_i_Pin_Dir, RTSI_Board_i_Output_Select.
RTSI_OSC	B9TU	RTSI Oscillator Source—RTSI_OSC is a bidirectional pin. Programmed as an input, it is the alternate timing source for the DAQ-STC. Programmed as an output, this pin carries the OSC signal. The pin is used for multiple-DAQ-STC synchronization across the RTSI bus. Source/Destination: RTSI bus. Related bitfields: RTSI_Clock_Mode.

6.4 Programming Information

This section presents programming information that is specific to the RTSI trigger. For general information about programming the DAQ-STC, see section [2.6, Programming Information](#).

6.4.1 Programming the RTSI Interface

This section contains detailed programming information for users who need to do bit-level programming of the RTSI interface for specialized applications.

Use the following function to program the RTSI interface.

```

Function MSC_RTSI_Pin_Configure
{
    switch (pin class)
    {
        case RTSI Trigger:
            switch (pin number)
            {
                case i:
                    RTSI_Trig_i_Pin_Dir = 0 (input) or 1 (output);
                    RTSI_Trig_i_Output_Select = 0 (ADR_START1) or 1
                    (ADR_START2) or 2 (SCLKG) or 3 (DACUPDN) or 4
                    (DA_START1) or 5 (G_SRC 0) or 6 (G_GATE 0) or 7 (RGOUT0) or
                    8 through 11 (RTSI_BRD<0..3>);
            }
        case RTSI Board:
            switch (pin number)
            {
                case i:
                    RTSI_Board_i_Pin_Dir = 0 (input) or 1 (output);
                    RTSI_Board_i_Output_Select = 0 through 6
                    (RTSI_TRIGGER<0..6>) or 7 (AI_STOP);
            }
        case RTSI Subselection:
            switch (pin number)
            {
                case 1:
                    RTSI_Sub_Selection_1 = 0 (general purpose counter 0 TC) or
                    1 (same as G_OUT/RTSI_IO pin);
                    break;
            }
    }
}

```

6.4.2 Bitfield Descriptions

Bits in the register bit maps are organized into bitfields. A bitfield can contain one or more bits. Only bits with contiguous locations within a register can belong to a bitfield. The high and low pairs of load and save registers for 24-bit counters are also treated as bitfields. The RTSI trigger-related bitfields are described below. Not all bitfields referred to in section 6.4, *Programming Information*, are listed here. To locate a particular bitfield description within this manual, refer to Appendix B, *Register Information*.

RTSI_Board_ *i* Output_Select

<i>i</i> = 0	bits: <0..2>	type: Write	in: RTSI_Board_Register	address: 81
<i>i</i> = 1	bits: <3..5>	type: Write	in: RTSI_Board_Register	address: 81
<i>i</i> = 2	bits: <6..8>	type: Write	in: RTSI_Board_Register	address: 81
<i>i</i> = 3	bits: <9..11>	type: Write	in: RTSI_Board_Register	address: 81

This bitfield selects the signal appearing on the RTSI_BRD*i* pin, if the pin is configured for output:

0–6: RTSI_TRIGGER<0..6>.

7: If *i* = 0–1, output the analog input STOP signal.

If *i* = 2–3, output the same signal that is selected to be output on the PFI7/AI_START pin.

Related bitfields: RTSI_Board_ *i* Pin_Dir, AI_START_Output_Select.

RTSI_Board_ *i* Pin_Dir

<i>i</i> = 0	bit: 12	type: Write	in: RTSI_Board_Register	address: 81
<i>i</i> = 1	bit: 13	type: Write	in: RTSI_Board_Register	address: 81
<i>i</i> = 2	bit: 14	type: Write	in: RTSI_Board_Register	address: 81
<i>i</i> = 3	bit: 15	type: Write	in: RTSI_Board_Register	address: 81

This bit selects the direction of the bidirectional pin RTSI_BRD*i*:

0: Input.

1: Output.

RTSI_Clock_Mode

bits: <0..1> **type:** Write **in:** RTSI_Trig_Direction_Register **address:** 58

This bitfield selects the internal timebase by specifying the way the OSC and the RTSI_OSC pins are used:

- 0: The signal from the OSC pin will be used as the internal timebase. The RTSI_OSC pin will not be configured for input (it will be in the pull-up high-impedance state).
- 1: The signal from the OSC pin will be used as internal timebase. The RTSI_OSC pin will be configured for output; it will propagate the signal coming from the OSC pin. In this mode, the signal from the OSC pin is used as the internal timebase directly; in other words, not after passing through the RTSI_OSC pin buffers.
- 2: Slave clock. The signal from the OSC pin will be ignored. The RTSI_OSC pin will be configured for input. The signal from the RTSI_OSC pin will be used as the internal timebase.
- 3: Master clock. The signal from the OSC pin will be used as the internal timebase. The RTSI_OSC pin will be configured for output; it will propagate the signal coming from the OSC pin. The signal from the OSC pin will pass through two buffers provided for use with the RTSI_OSC pin before becoming the internal timebase; this design provides the best master/slave clock synchronization.

RTSI_Sub_Selection_1

bit: 15 **type:** Write **in:** RTSI_Trig_B_Output_Register **address:** 80

This bit determines the signal propagated when any of the RTSI_Trig_*i*_Output_Select bitfields is set to 7 (to select the internal signal RGOUT0):

- 0: The G_OUT signal from general-purpose counter 0.
- 1: The signal present on the G_OUT0/RTSI_IO pin.

RTSI_Trig_ *i* Output Select

<i>i</i> = 0	bits: <0..3>	type: Write	in: RTSI_Trig_A_Output_Register	address: 79
<i>i</i> = 1	bits: <4..7>	type: Write	in: RTSI_Trig_A_Output_Register	address: 79
<i>i</i> = 2	bits: <8..11>	type: Write	in: RTSI_Trig_A_Output_Register	address: 79
<i>i</i> = 3	bits: <12..15>	type: Write	in: RTSI_Trig_A_Output_Register	address: 79
<i>i</i> = 4	bits: <0..3>	type: Write	in: RTSI_Trig_B_Output_Register	address: 80
<i>i</i> = 5	bits: <4..7>	type: Write	in: RTSI_Trig_B_Output_Register	address: 80
<i>i</i> = 6	bits: <8..11>	type: Write	in: RTSI_Trig_B_Output_Register	address: 80

This bitfield selects the signal appearing on the RTSI_TRIGGER_{*i*} pin if the pin is configured for output:

- 0: Internal analog input signal ADR_START1.
- 1: Internal analog input signal ADR_START2.
- 2: Internal analog input signal SCLKG.
- 3: Internal analog output signal DACUPDN.
- 4: Internal analog output signal DA_START1.
- 5: The G_SRC signal from general-purpose counter 0.
- 6: The G_GATE signal from general-purpose counter 0.
- 7: RGOUT0 (see RTSI_Sub_Selection_1).
- 8–11: Signal present at the RTSI_BRD pin 0–3.

Related bitfields: RTSI_Trig_*i*_Pin_Dir.

RTSI_Trig_ *i* Pin_Dir

<i>i</i> = 0	bit: 9	type: Write	in: RTSI_Trig_Direction_Register	address: 58
<i>i</i> = 1	bit: 10	type: Write	in: RTSI_Trig_Direction_Register	address: 58
<i>i</i> = 2	bit: 11	type: Write	in: RTSI_Trig_Direction_Register	address: 58
<i>i</i> = 3	bit: 12	type: Write	in: RTSI_Trig_Direction_Register	address: 58
<i>i</i> = 4	bit: 13	type: Write	in: RTSI_Trig_Direction_Register	address: 58
<i>i</i> = 5	bit: 14	type: Write	in: RTSI_Trig_Direction_Register	address: 58
<i>i</i> = 6	bit: 15	type: Write	in: RTSI_Trig_Direction_Register	address: 58

This bit selects the of the bidirectional pin RTSI_TRIGGER_{*i*}:

- 0: Input.
- 1: Output.

6.5 Detailed Description

When configured as inputs, the RTSI_TRIGGER pins provide an interface through which your timing I/O signals can be brought to the internal DAQ-STC modules. Each of the three main internal modules—AITM, AOTM, and GPCT—has 20-to-1 input multiplexers (PFI selectors) to select their relevant timing/control input signals. Refer to section 5.5, *Detailed Description*, for a complete list of the PFI selectors available in each module.

When configured as outputs, each RTSI_TRIGGER pin reflects the status of a particular signal related to the timing/control signals. The pins will power up as inputs and will be used primarily as inputs. The output capability on these pins is useful for synchronizing external circuitry to the board. Table 6-2 gives a list of the internal signals that are available as outputs on the RTSI_TRIGGER pins.

Table 6-2. RTSI_TRIGGER<0..6> Output Selections

RTSI_Trig_i_Output_Select	SIGNAL
0	The internal analog input signal ADR_START1
1	The internal analog input signal ADR_START2
2	The internal analog input signal SCLKG
3	The internal analog output signal DACUPDN
4	The internal analog output signal DA_START1
5	The G_SRC signal from general-purpose counter 0
6	The G_GATE signal from general-purpose counter 0
7	RGOUT0 (see RTSI_Sub_Selection_1)
8-11	The signal present at the RTSI_BRD pin 0–3

The four RTSI_BRD pins provide a mechanism for additional board-level signals to be sent on or received from the RTSI bus. Configured as an input, each bidirectional RTSI_BRD pin can drive any of the seven RTSI_TRIGGER pins. Configured as an output, each pin can be driven by any of the seven RTSI_TRIGGER pins. RTSI_BRD<0..1> can also be driven by AI STOP. RTSI_BRD<2..3> can also be driven by the AI START and SCAN_IN_PROG signals. Tables 6-3 and 6-4 summarize the available output selections on RTSI_BRD<0..3>.

Table 6-3. RTSI_BRD<0..1> Output Selections

RTSI_Board_i_Output_Select	SIGNAL
0–6	The signal present at the RTSI_TRIGGER pin 0–6
7	AI STOP

Table 6-4. RTSI_BRD<2..3> Output Selections

RTSI_Board_i_Output_Select	SIGNAL
0–6	The signal present at the RTSI_TRIGGER pin 0–6
7	<p>If AI_START_Output_Select is 0, this pin is defined as follows:</p> <ul style="list-style-type: none"> • If AI_Trigger_Length is 0, this pin reflects the internal signal AD_START. • If AI_Trigger_Length is 1, this pin reflects the internal signal AD_START after it has been pulse stretched to be 1–2 AI_OUT_TIMEBASE periods long. <p>If AI_START_Output_Select is 1, this pin will output the same signal as SCAN_IN_PROG.</p>

Digital I/O

7.1 Overview

This chapter describes the digital I/O (DIO) module and explains how to use it on the DAQ-STC. The DIO module contains eight high-current bidirectional digital I/O lines and serial I/O shift registers. The EXTSTROBE/SDCLK signal serves as the shift clock in the serial mode. Eight additional output lines, CTRL<0..7>, are provided for use as a board-level control register. Four additional lines, STATUS<0..3>, are provided for use as a board-level status register.

7.2 Features

The DIO module has the following features:

- Eight individually programmable bidirectional lines
- 24 mA sink current, 13 mA source current
- Serial I/O support for SCXI serial link on digital I/O lines
- Control and Status Registers
 - 8 output lines for use as a board-level control register
 - 4 input lines for use as a board status register

7.3 Simplified Model

The DIO module contains the hardware necessary to perform serial and parallel digital I/O, as well as support for a status and control register interface. Figure 7-1 shows a simplified model of the DIO module.

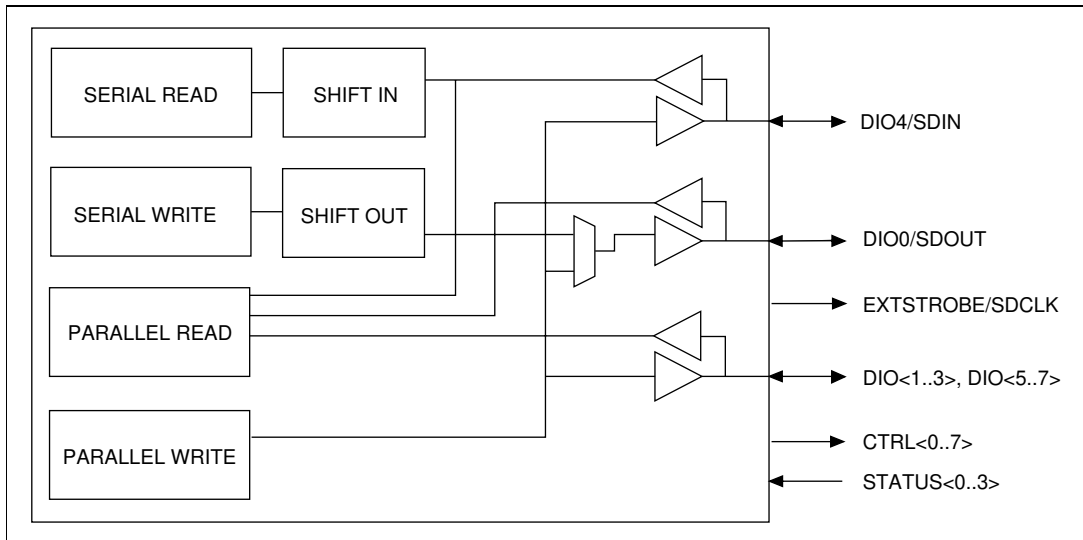

Figure 7-1. DIO Simplified Model

The bidirectional DIO<0..7> lines provide a port for 8-bit parallel I/O. When parallel I/O is not needed, the DIO4/SDIN and DIO0/SDOUT lines provide a port for 8-bit serial I/O. The signal EXTSTROBE/SDCLK can generate periodic timing for serial I/O or it can act as a software-controlled handshaking signal for both parallel and serial I/O. The STATUS<0..3> and CTRL<0..7> lines provide a board-level read and write register.

7.4 Overview of DIO Functions

The DIO module provides two modes of digital I/O operation—parallel mode and serial mode. In parallel mode, the DAQ-STC transfers data eight bits at a time under software control. In serial mode, the DAQ-STC transfers data one bit at a time under hardware control, with software initiating each 8-bit serial transfer. This section discusses the parallel and serial modes of operation.

7.4.1 Parallel Mode

In parallel I/O mode, eight bits are available for interfacing with a parallel port. The software outputs data asynchronously to the DIO port by writing the output data to the parallel output register. The software inputs data asynchronously from the DIO port by reading from the parallel input register. Software must perform handshaking to ensure that the data is read and written safely. The EXTSTROBE/SDCLK output is available for simple handshaking operations.

7.4.1.1 Parallel Input

In parallel input mode, an external device transfers 8-bit parallel data to the DAQ-STC through the DIO lines. Typically, software configures the external device to place a new data byte on the DIO lines based on EXTSTROBE/SDCLK, which is under software control. The DAQ-STC then reads the data lines after each EXTSTROBE/SDCLK pulse. Figure 7-2 shows a parallel input operation where the external device sends a new data byte on each EXTSTROBE/SDCLK falling edge. The DAQ-STC reads the data bytes 0x55 and 0xAA hex.

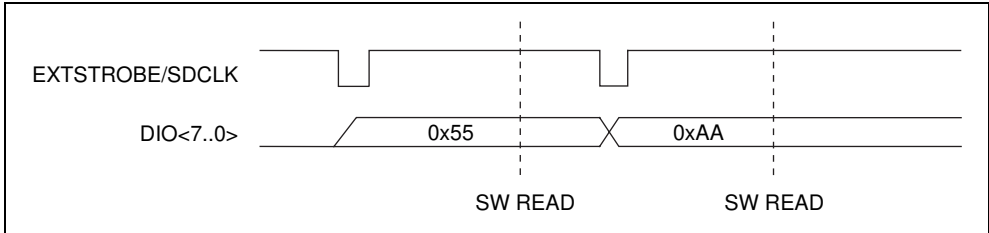

Figure 7-2. Parallel Input

7.4.1.2 Parallel Output

In parallel output mode, the DAQ-STC transfers 8-bit parallel data to an external device through the DIO lines. Typically, the software configures the external device to read a new data byte based on EXTSTROBE/SDCLK, which is under software control. The software then updates the DIO lines between each EXTSTROBE/SDCLK pulse. In this mode, the software must be careful not to exceed the maximum data transfer rate of the receiving device, or data loss may result. Figure 7-3 shows a parallel output operation where the external device receives a new data byte on each EXTSTROBE/SDCLK falling edge. The DAQ-STC transmits the data bytes 0x55 and 0xAA hex.

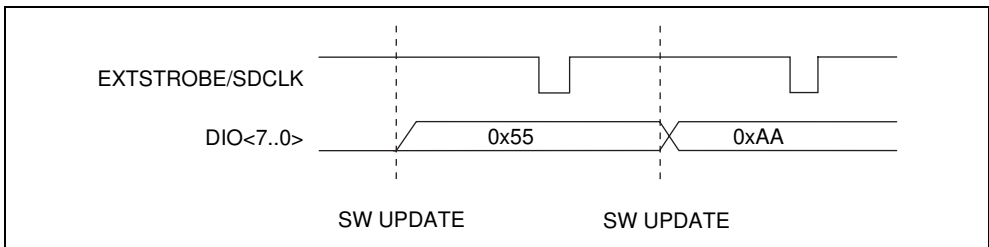

Figure 7-3. Parallel Output

7.4.2 Serial Mode

In serial mode, the DAQ-STC exchanges 8-bit wide data with an external device through two serial pins, one for each direction. Three sources are available for timing the serial data transfers—a 1.2 μs clock, a 10 μs clock, and a software-controlled clock. The external device receives timing from the DAQ-STC through the output EXTSTROBE/SDCLK.

7.4.2.1 Serial Input

In serial input mode, an external device transfers 8-bit serial data to the DAQ-STC through the DIO4/SDIN line. Software configures the external device to place a new data bit on the DIO4/SDIN line after each EXTSTROBE/SDCLK falling edge and selects EXTSTROBE/SDCLK to be one of the periodic timebases. The DAQ-STC clocks data from the DIO4/SDIN line on each EXTSTROBE/SDCLK rising edge. This arrangement allows the data line adequate time to stabilize before reading. The DAQ-STC only generates enough pulses on EXTSTROBE/SDCLK to complete the current 8-bit data transfer. Each 8-bit transfer is initiated under software control. Figure 7-4 shows a serial input operation where the DAQ-STC reads the data byte 0x4B hex.

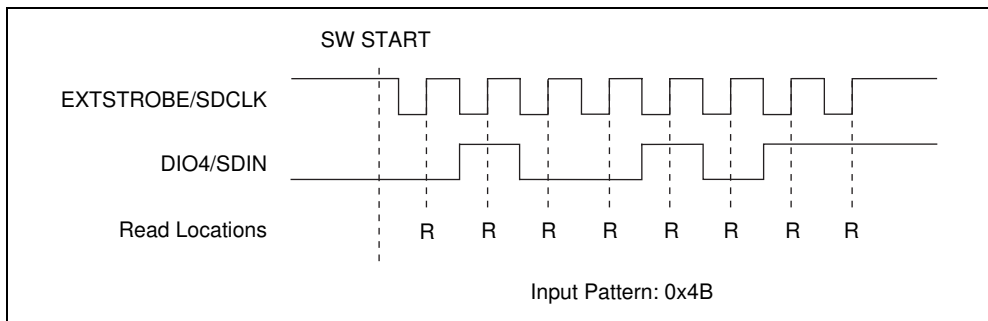

Figure 7-4. DIO Serial Input

7.4.2.2 Serial Output

In serial output mode, the DAQ-STC transfers 8-bit serial data to an external device through the DIO0/SDOUT line. Software configures the external device to read a new data bit on each EXTSTROBE/SDCLK rising edge and selects EXTSTROBE/SDCLK as one of the periodic timebases. The DAQ-STC places new data on the DIO0/SDOUT line every EXTSTROBE/SDCLK falling edge. This arrangement allows the data line adequate time to stabilize before reading. The DAQ-STC generates only enough pulses on EXTSTROBE/SDCLK to complete the current 8-bit data transfer. Each 8-bit transfer is initiated under software control. Figure 7-5 shows a serial input operation where the DAQ-STC outputs the data byte 0x4B hex.

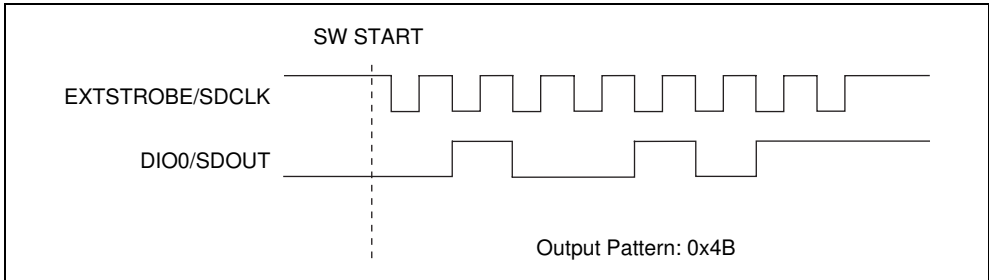

Figure 7-5. Serial Output

7.4.2.3 Serial I/O

It is possible for serial input and serial output to take place simultaneously on separate lines. In serial I/O mode, the DAQ-STC inputs data on the DIO4/SDIN line and outputs data on the DIO0/SDOUT line. Software configures the external device that is sending data as described in section 7.4.2.1, *Serial Input*, and configures the external device that is receiving data as described in section 7.4.2.2, *Serial Output*. Each 8-bit transfer is initiated under software control. Figure 7-6 shows a serial I/O operation where the DAQ-STC simultaneously reads the data byte 0x4B hex and outputs the data byte 0x97 hex.

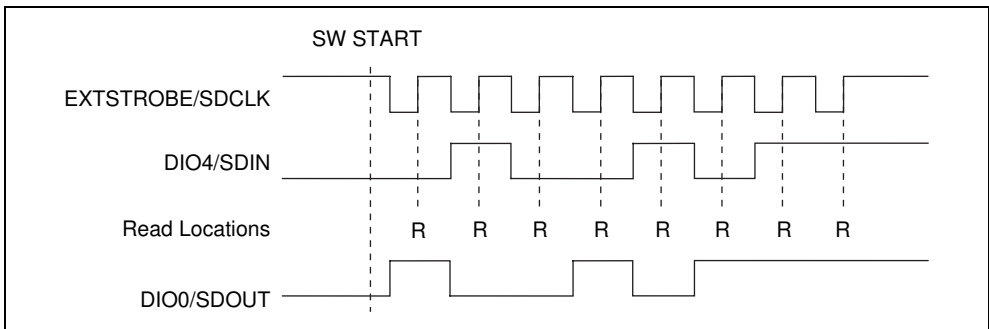

Figure 7-6. Serial I/O

7.5 Pin Interface

The I/O signals relevant to the DIO module are listed in the following table.

Pin Type Notation:

ID	TTL input, pull down (50 k Ω .)
O4TU	Output, 4 mA sink, 2.5 mA source tri-state, pull up (50 k Ω)
B18TU	Bidirectional, 24 mA sink, 13 mA source tri-state, pull up (50 k Ω)
O9TU	Output, 9 mA sink, 5 mA source tri-state, pull up (50 k Ω)

Table 7-1. Pin Interface

Pin Name	Type	Description
CTRL<0..7>	O4TU	Control<0..7>—These pins serve as general-purpose write strobes. These could be used to simplify adding board-level control registers or as clear strobes for the various FIFOs. Related bitfields: Control.
DIO0/SDOUT	B18TU	Digital I/O0/Serial Data Output—This bidirectional pin is one of the eight individually programmable DIO lines. This pin is also the serial port data output pin. The serial port implements communication with the SCXI at one of two selectable clock rates. See also EXTSTROBE/SDCLK. Related bitfields: DIO_Pins_Dir, DIO_Parallel_Data_In_St, DIO_Parallel_Data_Out, DIO_Serial_Data_Out.
DIO<1..3>	B18TU	Digital I/O Lines<1..3>—Individually programmable DIO lines. Related bitfields: DIO_Pins_Dir, DIO_Parallel_Data_In_St, DIO_Parallel_Data_Out.
DIO4/SDIN	B18TU	Digital I/O4/Serial Data Input—This bidirectional pin is one of the eight individually programmable DIO lines. This pin is also the serial port data input pin. The serial port implements communication with the SCXI at one of two selectable clock rates. See also EXTSTROBE/SDCLK. Related bitfields: DIO_Pins_Dir, DIO_Parallel_Data_In_St, DIO_Parallel_Data_Out, DIO_Serial_Data_In_St.
DIO<5..7>	B18TU	Digital I/O Lines<5..7>—Individually programmable DIO lines. Related bitfields: DIO_Pins_Dir, DIO_Parallel_Data_In_St, DIO_Parallel_Data_Out.

Table 7-1. Pin Interface (Continued)

Pin Name	Type	Description
EXTSTROBE*/SDCLK	O9TU	External Strobe/Serial Data Clock—This active low output signal can serve as the clock signal with either the parallel or serial data or serve as a general digital output. It is intended to be used in two modes: software-controlled mode or hardware-controlled serial clock mode. In the software-controlled mode, this bit is toggled under software-control. In the hardware-controlled serial clock mode, this pin serves as the clock signal associated with the serial data I/O pins. Parallel data output on DIO lines is used with the AMUX-64T. Serial data I/O is used with SCXI. Related bitfields: DIO_HW_Serial_Enable, DIO_HW_Serial_Timebase, DIO_Software_Serial_Control.
STATUS<0..3>	ID	Status<0..3>—These pins serve as a board status register. Related bitfields: AI_Generic_Status.

7.6 Programming Information

This section presents programming information that is specific to digital I/O. For general information about programming the DAQ-STC, see section 2.6, *Programming Information*.

7.6.1 Windowed Mode Register Access Example

The DAQ-STC register access method is illustrated by the following C code example.

```

/* The following code toggles the DIO lines on the DAQ-STC */
/* The AT-MIO E Series boards address mapping of the DAQ-STC is used */
/* to illustrate the addressing and access methods for the DAQ-STC */

#define Board_Base_Addr          0x280
#define DAQ_STC_Base_Addr      0x00 + Board_Base_Addr
                                /* DAQ_STC base address */
                                /* on the AT-MIO-E Series */

#define DAQ_STC_Window_Address_Reg  DAQ_STC_Base_Addr + 0x00
#define DAQ_STC_Window_Data_Write_Reg DAQ_STC_Base_Addr + 0x01*2
#define DAQ_STC_Window_Data_Read_Reg  DAQ_STC_Base_Addr + 0x01*2
#define DAQ_STC_DIO_Output_Register   0x0A
#define DAQ_STC_DIO_Control_Register  0x0B
#define DAQ_STC_DIO_All_Outputs       0xFF

```

```

main()
{
    int port_val;
    /* configure DIO<0..7> pins as outputs */
    DAQ_STC_Windowed_Mode_Write(DAQ_STC_DIO_Control_Register,
    DAQ_STC_DIO_All_Outputs);
    for (port_val = 0; port_val <= 255; port_val++)
    {
        DAQ_STC_Windowed_Mode_Write (DAQ_STC_DIO_Output_Register, port_val);
    } /*for port_val*/
} /*main */

/* functions to write and read from the DAQ-STC in the windowed mode */
/* outp performs a 16-bit write and inp performs a 16-bit read */

DAQ_STC_Windowed_Mode_Write(unsigned int addr, int data)

{
    outp (DAQ_STC_Window_Address_Reg, addr);
    outp (DAQ_STC_Window_Data_Write_Reg, data);
}

DAQ_STC_Windowed_Mode_Read (unsigned int addr, int *dataptr)

{
    outp (DAQ_STC_Window_Address_Reg, addr);
    inp (DAQ_STC_Window_Data_Read_Reg, &dataptr);
}

```



Caution *When using windowed-mode accesses from an interruptible process, your application may not function properly if an interrupt occurs between the time that the address is loaded into the Window_Address_Register and the time that an access is made from the Window_Data_Register. Make sure that the interrupt does not disturb the Window_Address_Register during this sensitive period. To do this, disable interrupts during windowed-mode accesses or write the interrupt routines so that they do not disturb the contents of the Window_Address_Register.*

7.6.2 Programming the Digital Interface

The DAQ-STC has eight DIO lines corresponding to pins DIO<0..7> and a digital output line, EXTSTROBE/SDCLK. The eight DIO lines can be configured for input or output on an individual basis. DIO4 can be used for 8-bit serial digital input, and line DIO0 can be used for 8-bit serial digital output.

To program the eight DIO pins for input or output, use the following function:

```
Function DIO_Pin_Configure
{
    DIO_Pins_Dir = [ijklmnop];
}
```

where i , j , k , l , m , n , o , and p are all binary digits, so that $[ijklmnop]$ is an eight-digit binary number. Use 0 to program a line for input and 1 to program it for output. Note that i corresponds to pin DIO7, j to pin DIO6, and so on.



Warning *You must be very careful when programming bidirectional pins for output. If an external signal is driving a bidirectional pin and you configure the pin for output, you may cause physical damage to the DAQ-STC, the external circuitry, or both.*

7.6.2.1 Parallel Digital I/O

Use the following function to program the value to be output on the DIO pins configured for output:

```
Function DIO_Parallel_Out
{
    DIO_Parallel_Data_Out = [ijklmnop];
}
```

where i , j , k , l , m , n , o , and p are all binary digits, so that $[ijklmnop]$ is an eight-digit binary number. Logic values corresponding to i , j , k , l , m , n , o , and p will appear on the DIO pins configured for output. Note that i corresponds to pin DIO7, j to pin DIO6, and so on. If you wish to change values on some pins and preserve values on others, you have to maintain a software copy of the value you write to `DIO_Parallel_Data_Out`.

Use the following function to read the value from the DIO pins:

```
Function DIO_Parallel_In
{
    [ijklmnop] = DIO_Parallel_Data_In_St;
}
```

Here i , j , k , l , m , n , o , and p are all binary digits corresponding to logic values on the DIO pins 7 through 0, so that $[ijklmnop]$ is an eight-digit binary number. Values corresponding to pins configured for input will reflect the state of the external digital signal connected to the pin. Values corresponding to the pins configured for output will reflect the values being output on those pins.

7.6.2.2 Hardware-Controlled Serial Digital I/O

DIO line 4 can be used for serial input, and DIO line 0 for serial output. Pin EXTSTROBE/SDCLK clocks the data by generating active low pulses at the times digital data on line 0 is valid. If you want the DAQ-STC to input data synchronously to the mentioned clock, circuitry connected to the DIO line 4 must have valid and stable data at those times. Pulse generation on the EXTSTROBE/SDCLK pin can be controlled by hardware or by software. This section presents the programming sequence for hardware-controlled pulse generation on the EXTSTROBE/SDCLK pin.

To perform 8-bit hardware-controlled serial output on pin 0, you must program pin DIO0 for output (see the function `DIO_Pin_Configure`). To perform 8-bit, hardware-controlled serial input on pin 4, you must program pin DIO4 for input (see the function `DIO_Pin_Configure`). Also, in either case you must enable the serial timebase using `Slow_Internal_Timebase` (see the function `Msc_Clock_Configure` in Chapter 10).

Use the following function to write data to be output on the serial digital output. Use the function `DIO_HW_Serial_Initialize` to initiate the transfer.

```
Function DIO_Serial_Data_Out
{
    DIO_Serial_Data_Out = [ijklmnop];
}
```

Here *i*, *j*, *k*, *l*, *m*, *n*, *o*, and *p* are all binary digits, so that *[ijklmnop]* is an eight-digit binary number. Logic values corresponding to *i*, *j*, *k*, *l*, *m*, *n*, *o*, and *p* will appear on DIO0 pin. Data will be output starting with *i* and ending with *p*; in other words, output starts with the MSB and ends with the LSB.

Use the following function to enable and configure the serial I/O. This function needs to be called only once.

```
Function DIO_HW_Serial_Configure
{
    DIO_Serial_Out_Divide_By_2 = 0 (do not divide by 2) or 1 (divide by 2);
    DIO_HW_Serial_Timebase = 0 (1.2 μs clock) or 1 (10 μs clock);
    DIO_HW_Serial_Enable = 1;
}
```

Use the following function to initiate a serial transfer.

```
Function DIO_HW_Serial_Initialize
{
    If (DIO_Serial_IO_In_Progress_St is 1) then
```



```

    {
        /* Serial I/O is already in progress. Cannot start now */
        Notify user that serial I/O is already in progress;
    }
    Else
        /*DIO_Serial_IO_In_Progress_St indicates when the first seven bits of serial I/O is
        in progress. A timed delay is necessary to allow the last bit to be transferred. */
        Delay;
        DIO_HW_Serial_Start = 1;
    }

```

Use the following function to read the data that has been input on the serial digital input. Use `DIO_Serial_IO_In_Progress_St` and a delay to verify that the transfer is complete.

```

Function DIO_Serial_In
{
    [qrstuvw] = DIO_Serial_Data_In_St;
}

```

Here *q*, *r*, *s*, *t*, *u*, *v*, *w*, and *x* are all binary digits corresponding to logic values input on the DIO4 pin, so that *[qrstuvw]* is an eight-digit binary number. The logic value *q* will correspond to the first bit, and *x* will correspond to the last bit input on pin DIO4.

```

Function Serial_DIO
{
    /* Serial DIO Output */
    Call DIO_Serial_Data_Out;

    /* Serial DIO Setup */
    Call DIO_HW_Serial_Configure;

    /* Serial DIO Start */
    Call DIO_HW_Serial_Initialize;

    /* Serial DIO Wait Loop */
    While (DIO_Serial_IO_In_Progress_St is 1) wait;

    /*Wait for last bit to be transferred*/
    Delay;

    /* Serial DIO Input */
    Call DIO_Serial_In;
}

```

If you do not need serial digital output, you can omit the *Serial DIO Output* section from your program.

If you do not need serial digital input, you can omit the *Serial DIO Input* section from your program. If, in addition, you know that no software running on your computer will need the

serial digital output line during the time required for eight bits to be output serially, you can also omit the *Serial DIO Wait Loop* section from your program.

To perform several serial digital I/O operations in sequence, the *Serial DIO Wait Loop* is necessary; however, you can exclude the *Serial DIO Setup* section from the programming sequence for all 8-bit data entities except the first.



Note *To perform serial output without the serial input, the value in `DIO_Serial_Data_In_St` will become undefined. You can perform serial output on pin DIO0 and ignore serial input data. You cannot perform hardware-controlled serial input on pin DIO4 and software-controlled parallel output on pin DIO0 at the same time unless you want to keep the same value on the pin DIO0 for the duration of the serial DIO. In this case you should program eight instances of this value in the `DIO_Serial_Data_Out` field before the serial DIO operation begins.*

7.6.2.3 Software-Controlled Serial Digital I/O

If hardware-controlled serial digital I/O is not used, the EXTSTROBE/SDCLK pin can be used as a digital output line. This enables you to select the direction of the eight DIO<0..7> pins and the EXTSTROBE/SDCLK pin for creating simple digital communication protocols. For example, you can configure pin DIO0 for output and pin DIO4 for input and perform operations similar to the one described in section [7.6.2.2, Hardware-Controlled Serial Digital I/O](#). To use the EXTSTROBE/SDCLK pin it this way, you must disable hardware control of it by setting the following bitfield.

```
DIO_HW_Serial_Enable = 0;
```

Use the following function to control the value on the EXTSTROBE/SDCLK pin:

```
Function DIO_Clock_Out
{
    DIO_Software_Serial_Control = 0 (for logic low) or 1 (for logic high);
}
```

7.6.2.4 Programming the Control Lines

Use the following function to set the generic control lines:

```
Function MSC_Generic_Control
{
    Control = output value;
}
```



Note *These are generic control lines. Refer to the user manual for your DAQ board or device for information on how these lines are used.*

7.6.2.5 Reading the Status Lines

Use the following function to read the generic status lines:

```
Function MSC_Generic_Status
{
    return(Generic_Status);
}
```



Note *These are generic status lines. Refer to the hardware manual for your DAQ board or device for information on how these lines are used.*

7.6.3 Bitfield Descriptions

Bits in the register bit maps are organized into bitfields. A bitfield can contain one or more bits. Only bits with contiguous locations within a register can belong to a bitfield. The high and low pairs of load and save registers for 24-bit counters are also treated as bitfields. The digital I/O-related bitfields are described below. Not all bitfields referred to in section 7.6, *Programming Information*, are listed here. To locate a particular bitfield description within this manual, refer to Appendix B, *Register Information*.

Control

bits: <8..15> **type:** Write **in:** Generic_Control_Register **address:** 71

This bitfield determines the value on the CTRL<0..7> pins. Refer to your board user manual for a description of the function of these pins.

DIO_HW_Serial_Enable

bit: 9 **type:** Write **in:** DIO_Control_Register **address:** 11

This bit enables hardware-controlled serial digital I/O:

- 0: Disabled. Use DIO_Software_Serial_Control bit to toggle EXTSTROBE/SDCLK pin.
- 1: Enabled. EXTSTROBE/SDCLK pin is controlled by serial hardware.

DIO_HW_Serial_Start

bit: 8 **type:** Strobe **in:** DIO_Control_Register **address:** 11

Setting this bit to 1 starts the hardware-controlled serial digital I/O if enabled. This bit is cleared automatically. Related bitfields: DIO_HW_Serial_Enable.

DIO_HW_Serial_Timebase

bit: 10 **type:** Write **in:** DIO_Control_Register **address:** 11

This bit selects the timebase used for the EXTSTROBE/SDCLK signal during hardware-controlled serial digital I/O:

- 0: SERIAL_TIMEBASE divided by 12 (1.2 μ s clock).
- 1: IN_TIMEBASE2.

You need to set DIO_Serial_Out_Divide_By_2 to 0 if a 10 MHz oscillator is used and to 1 if a 20 MHz oscillator is used to obtain the frequency indicated in parentheses. Use DIO_HW_Serial_Enable to enable hardware-controlled serial digital I/O. Related bitfields: DIO_Serial_Out_Divide_By_2, DIO_HW_Serial_Enable.

DIO_Parallel_Data_In_St

bits: <0..7> **type:** Read **in:** DIO_Parallel_Input_Register **address:** 7

This bitfield is used for digital input on DIO<0..7>. If a DIO line is configured for output, the corresponding bit in this register will reflect the output state.

DIO_Parallel_Data_Out

bits: <0..7> **type:** Write **in:** DIO_Output_Register **address:** 10

This bitfield is used for data to be output in parallel on DIO<0..7>.

DIO_Pins_Dir

bits: <0..7> **type:** Write **in:** DIO_Control_Register **address:** 11

This bitfield selects the directions of the bidirectional pins DIO<0..7>:

- 0: Input.
- 1: Output.

Use this field to configure all eight lines on a per line basis.

DIO_Serial_Data_In_St

bits: <0..7> **type:** Read **in:** DIO_Serial_Input_Register **address:** 28

This bitfield is used for serial digital input on DIO4. Do not attempt to read from this register while serial digital I/O is in progress. Related bitfields: DIO_Serial_IO_In_Progress.

DIO_Serial_Data_Out

bits: <8..15> **type:** Write **in:** DIO_Output_Register **address:** 10

This bitfield is used for data to be serially output on DIO0.

DIO_Serial_IO_In_Progress_St

bit: 12 **type:** Read **in:** Joint_Status_1_Register **address:** 27

This bit indicates whether the first seven bits of serial digital I/O is in progress:

- 0: Indicates that operation is not in progress, or that the last bit is being shifted out.
- 1: Indicates that one of the first seven bits is being shifted out.

Note that after this bit changes from 1 to 0 there is still one more bit of data to be shifted in/out. You must wait one more serial clock period for the operation to finish, which, for example, can be performed by a software delay loop or OS provided function.

DIO_Serial_Out_Divide_By_2

bit: 13 **type:** Write **in:** Clock_and_FOUT_Register **address:** 56

Divide the clock used for serial digital I/O timing by 2, provided hardware timing is used:

- 0: No. SERIAL_TIMEBASE is IN_TIMEBASE.
- 1: Yes. SERIAL_TIMEBASE is IN_TIMEBASE divided by 2.

DIO_Software_Serial_Control

bit: 11 **type:** Write **in:** DIO_Control_Register **address:** 11

If DIO_HW_Serial_Enable is set to 0, the inverted state of this bit is reflected on the EXTSTROBE/SDCLK pin.

Generic_Status

bits: <8..11> **type:** Read **in:** Joint_Status_2_Register **address:** 29

This bitfield reflects the value of the STATUS<0..3> pins.

7.7 Timing Diagrams

This section presents the timing for the serial DIO mode.

7.7.1 Serial Input Timing

In the serial-input mode, the rising edge of the EXTSTROBE/SDCLK signal clocks data on the DIO4/SDIN line. Figure 7-7 shows the setup and hold times for serial input.

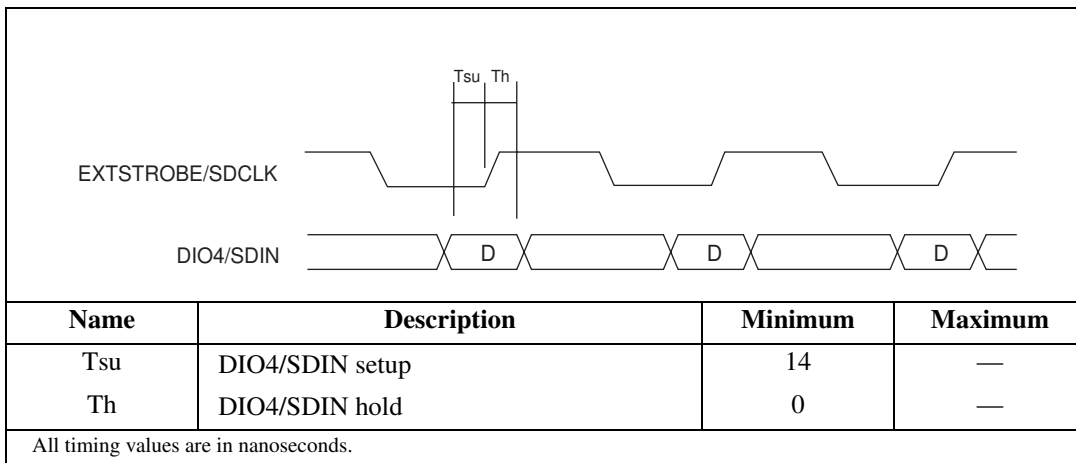

Figure 7-7. Serial Input Timing

7.7.2 Serial Output Timing

In the serial-output mode, the falling edge of the EXTSTROBE/SDCLK signal clocks data on the DIO0/SDOUT line. Figure 7-8 shows the propagation delay for serial output.

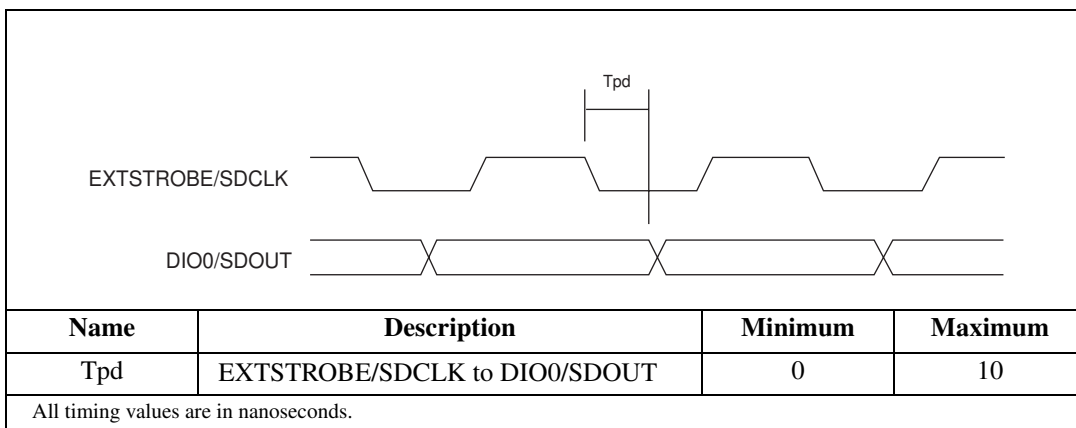

Figure 7-8. Serial Output Timing

7.8 Detailed Description

Two periodic timebases are available for timing the serial output—a 1.2 μs clock and a 10 μs clock. The clock is selected according to Table 7-2.

Table 7-2. Serial Output Source Select

DIO_HW_Serial_Timebase	Description
0	1.2 μs clock
1	10 μs clock

The DIO<0..7> directionality control is provided by DIO_Pins_Dir. Each of the eight digital lines can be individually configured using this bitfield. Two-way digital communication can be accomplished on the DIO lines by programming some of the lines for input and some for output. In parallel I/O mode, the bits in the read register that correspond to pins configured for output should be ignored. Similarly, the bits in the write register that correspond to pins configured for input are ignored by the hardware.

Interrupt Control

8.1 Overview

This chapter describes the interrupt control module (ICM), its features, and the conditions that cause interrupts. The ICM consists of two interrupt banks that can be routed to any two of the eight open drain, interrupt output lines. The ICM allows using one or two interrupt channel interfaces to the CPU. Interrupt group A handles the interrupts associated with the AITM, the board-level interrupt input IRQ_IN0, and interrupts associated with general-purpose counter 0. Interrupt group B handles the interrupts associated with the AOTM, board-level interrupt input IRQ_IN1, and interrupts associated with general-purpose counter 1.

The combined interrupt output of both interrupt groups can be enabled on the first two interrupt lines as well. This allows pairing up to three pins externally to increase the sink current capability. This is useful for buses such as the NuBus, which have a single-interrupt line but high-current sink requirements.

Two additional independently controlled outputs from each of the two interrupt groups are provided to simplify the interface for hardware acceleration of specific interrupt-driven tasks, such as general-purpose counter/timer input using DMA instead of interrupts. The additional independent interrupt outputs are called secondary interrupt outputs.

8.2 Features

The ICM has the following features:

- Eight tri-statable interrupt lines with high-current output stages for direct interface to the bus.
- Two interrupt groups with individual channel selections. Both groups can share the same interrupt channel.
- Two external interrupt inputs for board-level interrupts generated outside the DAQ-STC.
- 18 internally generated interrupt sources relating to the AITM, AOTM, and GPCT modules.
- Two additional independently controlled outputs for each group allow an additional mechanism for interrupt service.

8.3 Pin Interface

Table 8-1 lists the I/O signals relevant to the ICM.

Pin Type Notation:

ID TTL input, pull down (50 k Ω)
 OD18U Output open drain, 24 mA sink, pull up (50 k Ω)

Table 8-1. Pin Interface

Pin Name	Type	Description
IRQ_IN<0..1>	ID	Individually Programmable Polarity General-Purpose Interrupt Inputs<0..1> to the DAQ-STC—These inputs are enabled/disabled via registers in the DAQ-STC and passed on to the two interrupt groups in the DAQ-STC. Related bitfields: Pass_Thru_i_Interrupt_Enable, Pass_Thru_i_Second_Irq_Enable, Pass_Thru_i_Interrupt_Polarity.
IRQ_OUT<0..7>	OD18U	Programmable Polarity Interrupt Outputs<0..7> from the DAQ-STC. Two IRQ_OUT lines can be asserted simultaneously by the two interrupt groups in the DAQ-STC when an unmasked interrupt condition is true. Both interrupt groups can also share the same IRQ_OUT line, in which case only one IRQ_OUT line will be asserted. In addition, IRQ_OUT0 and IRQ_OUT1 can be enabled to be driven whenever any unmasked interrupt condition is true. These two outputs can be tied together to increase the current sink capability as required by NuBus. Destination: CPU bus. Related bitfields: Interrupt_A_Output_Select, Interrupt_A_Output_Enable, Interrupt_B_Output_Select, Interrupt_B_Output_Enable, Interrupt_Output_Polarity, Interrupt_Output_On_3_Pins.
SEC_IRQ_OUT_BANK0	OD18U	Secondary Interrupt Output for Interrupt Group A.
SEC_IRQ_OUT_BANK1	OD18U	Secondary Interrupt Output for Interrupt Group B.

8.4 Programming Information

This section presents programming information that is specific to the ICM. For general information about programming the DAQ-STC, see section 2.6, *Programming Information*.

8.4.1 Programming the Interrupt Interface

This section contains detailed programming information for users who need to do bit-level programming of the interrupt interface for specialized applications.

The DAQ-STC can be used as an interrupt management device. The DAQ-STC can generate interrupts on up to 18 internal conditions and can propagate two externally generated interrupts. Ten pins are provided for the interrupt interface: pins IRQ_OUT<0..7> can be used for interrupt assertion, and pins IRQ_IN<0..1> can be used for interrupt propagation.

Interrupts on the DAQ-STC are divided into groups A and B. Details are provided in section 8.4.2, *Interrupt Handling*.

8.4.1.1 Interrupt Output Polarity

Use the following function to select the logic level that will indicate an interrupt condition on the IRQ_OUT pins and to indicate whether you want the selected interrupt to be duplicated on the IRQ_OUT<0..1> pins.

```
Function MSC_IRQ_Personality
{
    Interrupt_Output_Polarity = 0 (for active high) or 1 (for active low);
    Interrupt_Output_On_3_Pins = 0 (disabled) or 1 (enabled);
}
```

8.4.1.2 Interrupt Output Select and Enable

Use the following function to select the IRQ_OUT pin that will indicate an interrupt condition in the interrupt group and to enable interrupts for the group.

```
Function MSC_IRQ_Configure
{
    switch (interrupt group)
    {
        case A:
            Interrupt_A_Output_Select = 0 through 7 (IRQ_OUT<0..7>);
            Interrupt_A_Enable = 0 (disabled) or 1 (enabled);
            break;
        case B:
            Interrupt_B_Output_Select = 0 through 7 (IRQ_OUT<0..7>);
```

```

        Interrupt_B_Enable = 0 (disabled) or 1 (enabled);
        break;
    }
}

```



Note *Two groups can share the same IRQ_OUT pin.*

You should set Interrupt_i_Output_Enable to 1 after selecting the interrupt polarity and appropriate IRQ_OUT pin number.

The described mechanism allows you to change interrupt levels during an operation. However, you should not change interrupt levels once an operation has begun because your ISR may not function properly.

8.4.1.3 Pass-Through Interrupt

Two conditions external to the DAQ-STC, if properly connected, can cause the chip circuitry to indicate an interrupt condition. The input pins IRQ_IN<0..1> can be used for this purpose. Your board hardware must be designed with this in mind for software to be able to take advantage of this DAQ-STC feature.

Use the following function to select the polarity of signal which will be used as an external interrupt.

```

Function MSC_Pass_Through_Polarity
{
    Pass_Thru_0_Interrupt_Polarity = 0 (active high) or 1 (active low);
    Pass_Thru_1_Interrupt_Polarity = 0 (active high) or 1 (active low);
}

```

Use the following function to enable the use of an external interrupt condition on pins IRQ_IN<0..1>.

```

Function MSC_Pass_Through_Interrupt
{
    switch (pass through interrupt)
    {
        case 0:
            Pass_Thru_0_Interrupt_Enable = 0 (disabled) or 1 (enabled);
            break;
        case 1:
            Pass_Thru_1_Interrupt_Enable = 0 (disabled) or 1 (enabled);
            break;
    }
}

```

Use the following function to enable the use of an external secondary interrupt condition on pins IRQ_IN<0..1>.

```
Function MSC_Pass_Through_Second_Irq
{
    switch (pass through secondary interrupt)
    {
        case 0:
            Pass_Thru_0_Second_Irq_Enable = 0 (disabled) or 1 (enabled);
            break;
        case 1:
            Pass_Thru_1_Second_Irq_Enable = 0 (disabled) or 1 (enabled);
            break;
    }
}
```



Note *You should set `Pass_Through_i_Interrupt_Enable` to 1 after selecting the interrupt polarity.*

8.4.2 Interrupt Handling

Up to 18 events occurring within the DAQ-STC and up to two events occurring outside the DAQ-STC can cause the DAQ-STC to assert an interrupt. This section presents a programming sequence you can use to determine which of the many conditions caused the interrupt. You will find suggestions for interrupt-servicing programs in the other chapters of this manual.

Keep a record of interrupts that you enable so that you can determine which condition caused the interrupt. You should have software copies of all the relevant write-only registers. It is assumed that you want to service every condition that can cause an interrupt.

For instructions on programming the physical interrupt interface circuitry, see section [8.4.1, *Programming the Interrupt Interface*](#). For information on how your system uses the DAQ-STC interrupts, consult your hardware and computer manuals.

Conditions that can cause interrupts are divided into group A and group B. Group A contains conditions generated by or related to analog input control and timing circuitry, general-purpose counter 0, and pass-through interrupt 0. Group B contains conditions generated by or related to analog output control and timing circuitry, general-purpose counter 1, and pass-through interrupt 1. You can enable the two groups independently, and you can choose any of the eight interrupt levels for each group, or the two groups can share an interrupt level.

The following sections present the functions that should be executed when an appropriate interrupt is asserted.

8.4.2.1 Interrupt Program

If both groups are enabled and share the same interrupt level, your service program should test all the possible causes of interrupt and react to each one of them. You can use the following function.

```
Function Shared_Level_Service
{
    Declare variable done;
    done = 0;
    While (done is 0) do
    {
        If (Interrupt_A_St is 1) then
            Call Service_Group_A;
        Else if (Interrupt_B_St is 1) then
            Call Service_Group_B;
        Else done = 1;
    }
}
```

8.4.2.2 Interrupt Group A

Group A contains the following interrupts:

- Analog input: Error, START, STOP, START1, START2, SC_TC, and FIFO conditions.
- General-purpose counter 0: G0 TC and G0 Gate.
- Pass-through interrupt: Pass-Through interrupt 0.

Use the following function to service an interrupt generated by group A. The same sequence can be applied if the two groups share the interrupt level and the function `Shared_Level_Service` is used and if the interrupt level is dedicated to group A.

```
Function Service_Group_A
{
    Declare variable done_a;
    done_a = 0;
    While (done_a is 0) do
    {
        If (Soft_Copy(AI_FIFO_Interrupt_Enable) is 1) then
        {
            If (AI_FIFO_Request_St is 1) then
            {
                /*AI FIFO caused the interrupt*/
                Service AI FIFO interrupt;
                /*You cannot explicitly acknowledge a FIFO interrupt. You must perform
                an action external*/
            }
        }
    }
}
```

```

        /* to the DAQ-STC in order to clear this interrupt condition*/
    }
}
Else if (Soft_Copy(Pass_Thru_0_Interrupt_Enable) is 1) then
{
    If (Pass_Thru_0_Interrupt_St is 1) then
    {
        /*The interrupt was caused by signal entering DAQ-STC through the
        IRQ_IN0 pin*/
        Service the external interrupt 0;
        /*You cannot explicitly acknowledge a pass-through interrupt. You must
        perform an action*/
        /*external to the DAQ-STC in order to clear this interrupt condition.
        Normally, board hardware*/
        /*should be designed so that you can cause this action*/
        /*To enable this interrupt, set AI_Pass_Thru_0_Interrupt_Enable = 1*/
    }
}
Else if (SoftCopy(G0_TC_Interrupt_Enable) is 1) then
{
    If (G0_TC_St = 1) then
    {
        /*The interrupt was caused by general-purpose counter 0 TC*/
        Service the general-purpose counter 0 TC interrupt;
        /*To clear this interrupt, set G0_TC_Interrupt_Ack = 1*/
        /*To enable this interrupt, set G0_TC_Interrupt_Enable = 1*/
    }
}
Else if (G0_Gate_Interrupt_St is 1) then
{
    /*The interrupt was caused by appropriate event that occurred on gate of
    general-purpose counter 0*/
    Service the general-purpose counter 0 gate interrupt;
    /*To clear this interrupt, set G0_Gate_Interrupt_Ack = 1*/
    /*To enable this interrupt, set G0_Gate_Interrupt_Enable = 1*/
}
Else if (Soft_Copy(AI_SC_TC_Interrupt_Enable) is 1) then
{
    If (AI_SC_TC_St is 1) then
    {
        /*The interrupt was caused by AI SC_TC signal*/
        Service the AI SC_TC interrupt;
        /*To clear this interrupt, set AI_SC_TC_Interrupt_Ack = 1*/
        /*To enable this interrupt, set AI_SC_TC_Interrupt_Enable = 1*/
    }
}
Else if (Soft_Copy(AI_START1_Interrupt_Enable) is 1) then

```

```

{
  If (AI_START1_St is 1) then
  {
    /*The interrupt was caused by AI START1 signal*/
    Service the AI START1 interrupt;
    /*To clear this interrupt, set AI_START1_Interrupt_Ack = 1*/
    /*To enable this interrupt, set AI_START1_Interrupt_Enable = 1*/
  }
}
Else if (Soft_Copy(AI_START2_Interrupt_Enable) is 1) then
{
  If (AI_START2_St is 1) then
  {
    /*The interrupt was caused by AI START2 signal*/
    Service the AI START2 interrupt;
    /*To clear this interrupt, set AI_START2_Interrupt_Ack = 1*/
    /*To enable this interrupt, set AI_START2_Interrupt_Enable = 1*/
  }
}
Else if (Soft_Copy(AI_Error_Interrupt_Enable) is 1) then
{
  If ((AI_Overrun_St is 1) or (AI_Overflow_St is 1)) then
  {
    /*The interrupt was caused by one or both errors*/
    Service the AI error interrupt;
    /*To clear this interrupt, set AI_Error_Interrupt_Ack = 1*/
    /*To enable this interrupt, set AI_Error_Interrupt_Enable = 1*/
  }
}
Else if (Soft_Copy(AI_STOP_Interrupt_Enable) is 1) then
{
  If (AI_STOP_St is 1) then
  {
    /*The interrupt was caused by AI STOP signal*/
    Service the AI STOP interrupt;
    /*To clear this interrupt, set AI_STOP_Interrupt_Ack = 1*/
    /*To enable this interrupt, set AI_STOP_Interrupt_Enable = 1*/
  }
}
Else if (Soft_Copy(AI_START_Interrupt_Enable) is 1) then
{
  If (AI_START_St is 1) then
  {
    /*The interrupt was caused by AI START signal*/
    Service the AI START interrupt;
    /*To clear this interrupt, set AI_START_Interrupt_Ack = 1*/
    /*To enable this interrupt, set AI_START_Interrupt_Enable = 1*/
  }
}

```

```

    }
    Else done_a = 1;
  }
}

```

8.4.2.3 Interrupt Group B

Interrupt group B contains the following interrupts.

- Analog output: error, STOP, START, START1, BC_TC, UC_TC, and FIFO conditions.
- General-purpose counter 1: G1 TC and G1 Gate.
- Pass-through interrupt: Pass-Through interrupt 1.

The following function should be used to service an interrupt generated by group B. The same sequence can be applied if the two groups share the interrupt level and the function `Shared_Level_Service` is used and if the interrupt level is dedicated to group B.

Function `Service_Group_B`

```

{
  Declare variable done_b;
  done_b = 0;
  While (done_b is 0) do
  {
    If (Soft_Copy(AO_FIFO_Interrupt_Enable) is 1) then
    {
      If (AO_FIFO_Request_St is 1) then
      {
        /*AO FIFO caused the interrupt*/
        Service AO FIFO interrupt;
        /*You cannot explicitly acknowledge a FIFO interrupt. You must perform
        an action external to the DAQ-STC in order to clear this interrupt
        condition*/
      }
    }
    Else if (Soft_Copy(Pass_Thru_1_Interrupt_Enable) is 1) then
    {
      If (Pass_Thru_1_Interrupt_St is 1) then
      {
        /*The interrupt was caused by a signal entering the DAQ-STC through the
        IRQ_IN1 pin*/
        Service the external interrupt 0;
        /*You cannot explicitly acknowledge a pass-through interrupt. You must
        perform an action*/ /*external to the DAQ-STC in order to clear this
        interrupt condition. Normally, board hardware*/ /*should be designed so
        that you can cause this action*/
        /*To enable this interrupt, set AI_Pass_Thru_1_Interrupt_Enable = 1*/
      }
    }
  }
}

```



```

}
Else if (Soft_Copy(AO_UI2_TC_Interrupt_Enable) is 1) then
{
    If (AO_UI2_TC_Interrupt_St is 1) then
    {
        /*The interrupt was caused by AO UI2_TC, that is, the UPDATE2 signal*/
        Service the AO UI2_TC interrupt;
        /*To clear this interrupt, set AI_UI2_TC_Interrupt_Ack = 1*/
        /*To enable this interrupt, set AI_UI2_TC_Interrupt_Enable = 1*/
    }
}
Else if (Soft_Copy(G1_TC_Interrupt_Enable) is 1) then
{
    If (G1_TC_St is 1) then
    {
        /*The interrupt was caused by general-purpose counter 0 TC*/
        Service the general-purpose counter 0 TC interrupt;
        /*To clear this interrupt, set G1_TC_Interrupt_Ack = 1*/
        /*To enable this interrupt, set G1_TC_Interrupt_Enable = 1*/
    }
}
Else if (G1_Gate_Interrupt_St is 1) then
{
    /*The interrupt was caused by an appropriate event that occurred on the gate
of*/
    /*general-purpose counter 0*/
    Service the general-purpose counter 0 gate interrupt;
    /*To clear this interrupt, set G1_Gate_Interrupt_Ack = 1*/
    /*To enable this interrupt, set G1_Gate_Interrupt_Enable = 1*/
}
Else if (Soft_Copy(AO_BC_TC_Interrupt_Enable) is 1) then
{
    If (AO_BC_TC_St is 1) then
    {
        /*The interrupt was caused by AO BC_TC signal*/
        Service the AO BC_TC interrupt;
        /*To clear this interrupt, set AO_BC_TC_Interrupt_Ack = 1*/
        /*To enable this interrupt, set AO_BC_TC_Interrupt_Enable*/
    }
}
Else if (Soft_Copy(AO_UC_TC_Interrupt_Enable) is 1) then
{
    If (AO_UC_TC_St is 1) then
    {
        /*The interrupt was caused by AO UC_TC signal*/
        Service the AO BU_TC interrupt;
        /*To clear this interrupt, set AO_UC_TC_Interrupt_Ack = 1*/
    }
}

```

```

        /*To enable this interrupt, set AO_UC_TC_Interrupt_Enable = 1*/
    }
}
Else if (Soft_Copy(AO_START1_Interrupt_Enable) is 1) then
{
    If (AO_START1_St is 1) then
    {
        /*The interrupt was caused by AO START1 signal*/
        Service the AO START1 interrupt;
        /*To clear this interrupt, set AO_START1_Interrupt_Ack = 1*/
        /*To enable this interrupt, set AO_START1_Interrupt_Enable = 1*/
    }
}
Else if (Soft_Copy(AO_UPDATE_Interrupt_Enable) is 1) then
{
    If (AO_UPDATE_St is 1) then
    {
        /*The interrupt was caused by AO UPDATE signal*/
        Service the AO UPDATE interrupt;
        /*To clear this interrupt, set AO_UPDATE_Interrupt_Ack = 1*/
        /*To enable this interrupt, set AO_UPDATE_Interrupt_Enable = 1*/
    }
}
Else if (Soft_Copy(AO_Error_Interrupt_Enable) is 1) then
{
    If (AO_Overrun_St is 1) then
    {
        /*The interrupt was caused by one or both errors*/
        Service the AO error interrupt;
        /*To clear this interrupt, set AO_Error_Interrupt_Ack = 1*/
        /*To enable this interrupt, set AO_Error_Interrupt_Enable = 1*/
    }
}
Else if (Soft_Copy(AO_STOP_Interrupt_Enable) is 1) then
{
    If (AO_STOP_St is 1) then
    {
        /*The interrupt was caused by AO STOP signal*/
        Service the AO STOP interrupt;
        /*To clear this interrupt, set AO_STOP_Interrupt_Ack = 1*/
        /*To enable this interrupt, set AO_STOP_Interrupt_Enable = 1*/
        /*This interrupt is not supported*/
    }
}
Else if (Soft_Copy(AO_START_Interrupt_Enable) is 1) then
{
    If (AO_START_St is 1) then

```

```

        {
            /*The interrupt was caused by AO START signal*/
            Service the AO START interrupt;
            /*To clear this interrupt, set AO_START_Interrupt_Ack = 1*/
            /*To enable this interrupt, set AO_START_Interrupt_Enable = 1*/
            /*This interrupt is not supported*/
        }
    }
    Else done_b = 1;
}
}

```

The functions presented in this section can always be used. However, you can also consider them to be only examples. If your application uses fewer than the full number of interrupts listed here, your interrupt service programs will be more efficient if you omit appropriate parts of the code. You can also improve performance by modifying the order of evaluation of interrupt-causing conditions. You will often be able to take advantage of your knowledge of the application to write interrupt service programs that are fine-tuned to the particular application.

8.4.3 Bitfield Descriptions

Bits in the register bit maps are organized into bitfields. A bitfield can contain one or more bits. Only bits with contiguous locations within a register can belong to a bitfield. The high and low pairs of load and save registers for 24-bit counters are also treated as bitfields. The interrupt control-related bitfields are described below. Not all bitfields referred to in section 8.4, *Programming Information*, are listed here. To locate a particular bitfield description within this manual, refer to Appendix B, *Register Information*.

Interrupt_A_Enable

bit: 11 **type:** Write **in:** Interrupt_Control_Register **address:** 59

This bit enables interrupt request generation on the IRQ_OUT pin selected by Interrupt_A_Output_Select:

- 0: Disabled.
- 1: Enabled.

Related bitfields: Interrupt_A_Output_Select.

Interrupt_A_Output_Select

bits: <8..10> **type:** Write **in:** Interrupt_Control_Register **address:** 59

This bit selects the output pin IRQ_OUT<0..7> for interrupt group A:
0–7: IRQ_OUT<0..7>.

Interrupt_A_St**bit:** 15 **type:** Read **in:** AI_Status_1_Register **address:** 2

This bit indicates whether an interrupt is asserted in interrupt group A:

- 0: No interrupts asserted.
- 1: At least one interrupt asserted.

Interrupt_B_Enable**bit:** 15 **type:** Write **in:** Interrupt_Control_Register **address:** 59

This bit enables interrupts request generation on the IRQ_OUT pin selected by Interrupt_B_Output_Select.

- 0: Disabled.
- 1: Enabled.

Related bitfields: Interrupt_B_Output_Select.

Interrupt_B_Output_Select**bit:** <12..14> **type:** Write **in:** Interrupt_Control_Register **address:** 59

This bit selects the output pin IRQ_OUT<0..7> for interrupt group B:

- 0-7: IRQ_OUT<0..7>.

Interrupt_B_St**bit:** 15 **type:** Read **in:** AO_Status_1_Register **address:** 3

This bit indicates whether an interrupt is asserted in interrupt group B:

- 0: No interrupt asserted.
- 1: At least one interrupt asserted.

Interrupt_Output_On_3_Pins**bit:** 1 **type:** Write **in:** Interrupt_Control_Register **address:** 59

This bit enables output on IRQ_OUT lines 0 and 1 in addition to the IRQ_OUT lines specified by Interrupt_A_Output_Select and Interrupt_B_Output_Select when an interrupt request is generated in either group. This is useful because of the NuBus interrupt line current drive requirements. Additional output on IRQ_OUT0 and IRQ_OUT1 pins is:

- 0: Disabled.
- 1: Enabled.

Interrupt_Output_Polarity**bit:** 0 **type:** Write **in:** Interrupt_Control_Register **address:** 59

This bit selects the polarity of the IRQ_OUT<0..7> output signals:

- 0: Active high.
- 1: Active low.

Pass_Thru_ *i* Interrupt_Enable

<i>i</i> = 0	bit: 9	type: Write	in: Interrupt_A_Enable_Register	address: 73
<i>i</i> = 1	bit: 11	type: Write	in: Interrupt_B_Enable_Register	address: 75

This bit enables the pass through *i* interrupt:

- 0: Disabled.
- 1: Enabled.

Related bitfields: Pass_Thru_ *i* Interrupt_Polarity.

Pass_Thru_ *i* Interrupt_Polarity

<i>i</i> = 0	bit: 3	type: Write	in: Interrupt_Control_Register	address: 59
<i>i</i> = 1	bit: 2	type: Write	in: Interrupt_Control_Register	address: 59

This bit selects the polarity of the IRQ_IN input signal:

- 0: Active high.
- 1: Active low.

Pass_Thru_ *i* Interrupt_St

<i>i</i> = 0	bit: 0	type: Read	in: AI_Status_1_Register	address: 2
<i>i</i> = 1	bit: 0	type: Read	in: AO_Status_1_Register	address: 3

This bit indicates whether a pass through *i* interrupt is asserted:

- 0: Interrupt not asserted.
- 1: Interrupt asserted.

Pass_Thru_ *i* Second_Irq_Enable

<i>i</i> = 0	bit: 9	type: Write	in: Second_Irq_A_Enable_Register	address: 74
<i>i</i> = 1	bit: 11	type: Write	in: Second_Irq_B_Enable_Register	address: 76

This bit enables the pass through *i* interrupt in the secondary interrupt bank:

- 0: Disabled.
- 1: Enabled.

Related bitfields: Pass_Thru_ *i* Interrupt_Polarity.

8.5 Interrupt Conditions

Table 8-2 summarizes the DAQ-STC interrupts and indicates the condition that causes each interrupt, when the interrupt is enabled

Table 8-2. Interrupt Condition Summary

Interrupt	Condition
AI FIFO Interrupt	Interrupts are generated on the FIFO condition indicated by AI_FIFO_Mode.
AI Error Interrupt	Interrupts are generated on the detection of an analog input overrun or overflow error condition.
AI SC_TC Interrupt	Interrupts are generated on every SC_TC falling edge unless the pretrigger acquisition mode is selected. In the pretrigger acquisition mode, the first SC_TC falling edge does not generate an interrupt, but subsequent SC_TC falling edges do.
AI START1 Interrupt	Interrupts are generated on valid START1 triggers received by the AITM. A valid START1 trigger is one that is received while the SC counter is armed and in the WAIT1 state. The actual interrupt signal appears on the active edge of SC_CLK.
AI START2 Interrupt	Interrupts are generated on valid START2 triggers received by the AITM. A valid START2 trigger is one that is received while the SC counter is in the WAIT2 state. The actual interrupt signal appears on the active edge of SC_CLK.
AI START Interrupt	Interrupts are generated on valid START triggers received by the AITM. A valid START trigger is one that is received while the SC counter is enabled to count. The actual interrupt signal appears on the active edge of SC_CLK.
AI STOP Interrupt	Interrupts are generated on valid STOP triggers recognized by the AITM. A valid STOP trigger is one that is received while the SC counter is enabled to count. The actual interrupt signal appears on the active edge of SC_CLK. Note that this interrupt must be used in conjunction with the START interrupt.
G0 TC Interrupt	Interrupts are generated on the leading edge of the G_TC signal from general-purpose counter 0.
G0 Gate Interrupt	Interrupts are generated on the G_CONTROL signal from general-purpose counter 0. Refer to section 4.8.7, <i>Gate Actions</i> , for a complete description.

Table 8-2. Interrupt Condition Summary (Continued)

Interrupt	Condition
AO FIFO Interrupt	Interrupts are generated on the analog output FIFO condition indicated by AO_FIFO_Mode bitfield.
AO Error Interrupt	Interrupts are generated on the analog output FIFO condition indicated by AO_FIFO_Mode bitfield. Interrupts are generated on the detection of an analog output overrun error condition.
AO UI2_TC Interrupt	Interrupts are generated on the trailing edge of the internal AO signal UPDATE2.
AO UC_TC Interrupt	Interrupts are generated on the leading edge of the internal AO signal UC_TC.
AO BC_TC Interrupt	Interrupts are generated on the trailing edge of the internal AO signal BC_TC.
AO UPDATE Interrupt	Interrupts are generated on the trailing edge of the internal AO signal UPDATE.
AO START1 Interrupt	Interrupts are generated on AO START1 pulses recognized by the AOTM. AO START1 is recognized on the active edge of the internal AO signal BC_CLK.
G1 TC Interrupt	Interrupts are generated on the leading edge of the G_TC signal from general-purpose counter 1.
G1 Gate Interrupt	Interrupts are generated on the G_CONTROL signal from general-purpose counter 1. Refer to section 4.8.7, <i>Gate Actions</i> for a complete description.
Pass-Through Interrupt 0	Interrupts are generated when the IRQ_IN0 pin is asserted.
Pass-Through Interrupt 1	Interrupts are generated when the IRQ_IN1 pin is asserted.

Bus Interface

9.1 Overview

This chapter describes the features of the bus interface module, gives programming instructions, and presents the timing diagrams for the bus interface. The bus interface module implements a flexible window address mapping scheme to access the internal registers of the DAQ-STC. The entire address space of the DAQ-STC is always indirectly accessible via two window registers—address and data.

Two accesses to the DAQ-STC are required for each access to an internal register via the window registers. This allows the DAQ-STC to be used in systems with address space limitations such as the ISA. The entire address space is also directly accessible for systems where address space is not a problem. A mixed-mode implementation of the address space, such as eight registers accessed directly and the remaining registers accessed in windowed mode, is desirable for the ISA bus. The frequently used registers have lower addresses to allow direct access to these registers in this mixed-mode implementation.

9.2 Features

The DAQ-STC bus interface has the following features:

- Intel- or Motorola-type bus interface selection
- Flexible windowed address space
 - Requires minimum of two words of address space
 - Scalable address space to suit host system
 - Direct addressing is possible

9.3 Pin Interface

The I/O signals relevant to the Bus Interface are listed in the following table. An asterisk following a pin name indicates that the default polarity for that pin is active low.

Pin Type Notation:

ID	TTL input, pull down (50 k Ω)
IU	Input, pull up (50 k Ω)

IU5	Input, pull up (5 k Ω)
O4TU	Output, 4 mA sink, 2.5 mA source tri-state, pull up (50 k Ω)
OD18U	Output open drain, 24 mA sink, pull up (50 k Ω)
B9TU	Bidirectional, 9 mA sink, 5 mA source tri-state, pull up (50 k Ω)

Table 9-1. Pin Interface

Pin Name	Type	Description
A<1..7>	ID	Address—This active high address signal selects the register during a read or write operation. The entire address space is always accessible via two word locations—the address register (A<1..7> = 0) and the data register (A<1..7> = 1). This provides a flexible window interface. The DAQ-STC can occupy 2-128 words in the address space of the host system. If less than seven address lines are used, the unused address inputs should be tied low. In this case, two accesses are required to read from or write to one of the indirectly addressed registers. Frequently accessed registers occupy lower addresses in the address space of the DAQ-STC so that they can be accessed directly. Source: CPU bus.
CHRDY_IN	IU5	Board-Level Channel Ready—When CHRDY_IN is deasserted, the DAQ-STC deasserts CHRDY_OUT, requesting that the CPU bus extend the current bus cycle.
CHRDY_OUT	OD18U	Channel Ready Output—This is an active high signal used for bus cycle extension. This signal is driven low when a bus cycle needs to be extended. A bus cycle extension can occur due to a board-level request (CHRDY_IN) or it can occur when the CPU tries to access a D/A converter during a DAQ-STC write to the D/A converters. Destination: CPU bus.
CS*	IU	Chip Select—This is an active low signal to activate the DAQ-STC to read from or write to one of the registers. Source: CPU bus.
D<0..15>	B9TU	Bidirectional Tri-State Data Bus—This signal transfers data between the DAQ-STC and the CPU. Source/Destination: CPU bus.
INTEL/MOTO*	IU	Intel/Motorola Bus Interface Selection—Intel mode uses RD and WR signals. Motorola mode uses R/W and DS signals.

Table 9-1. Pin Interface (Continued)

Pin Name	Type	Description
RD/WR*	IU	<p>In Intel mode, RD/WR = RD—This is an active low input signal indicating a read bus cycle from the host system so that the DAQ-STC will drive the data bus.</p> <p>In Motorola mode, RD/WR = R/W—This is a read/write input signal indicating that the current bus cycle is a read (high) or write (low) cycle. The mode is set using the INTEL/MOTO pin. Source: CPU bus.</p>
RESET*	IU	<p>Reset—This is an active low signal that resets the DAQ-STC during initialization. Related bitfields: Software_Reset.</p>
WR/DS*	IU	<p>In Intel mode, WR/DS = WR—This is an active low input signal that indicates that the current bus cycle is a write cycle and that the CPU has placed valid data on the data bus.</p> <p>In Motorola mode, WR/DS = DS—This is an active low input signal that indicates that the DAQ-STC should drive the data bus during a read cycle and that the CPU has placed valid data on the data bus during a write cycle. Source: CPU bus. The mode is set using the INTEL/MOTO pin.</p>
WRITE_STROBE<0..3>	04TU	<p>Write Strobe—These pins serve as general-purpose write strobes. These could be used to simplify adding board-level control registers or as clear strobes for the various FIFOs. Related bitfields: Write_Strobe_0, Write_Strobe_1, Write_Strobe_2, Write_Strobe_3.</p>

9.4 Programming Information

This section presents programming information that is specific to the bus interface. For general information about programming the DAQ-STC, see section 2.6, [Programming Information](#).

9.4.1 Programming the Write Strobes

Use the following function to pulse the write strobe signals WRITE_STROBE<0..3>.

```
Function MSC_Write_Strobe
{
    switch (strobe number)
    {
        case 0:
            Write_Strobe_0 = 1;
            break;
        case 1:
            Write_Strobe_1 = 1;
            break;
        case 2:
            Write_Strobe_2 = 1;
            break;
        case 3:
            Write_Strobe_3 = 1;
            break;
    }
}
```



Note

These are generic strobe lines. Refer to the hardware manual for your DAQ board or device for information on how these lines are used.

9.4.2 Bitfield Descriptions

Bits in the register bit maps are organized into bitfields. A bitfield can contain one or more bits. Only bits with contiguous locations within a register can belong to a bitfield. The high and low pairs of load and save registers for 24-bit counters are also treated as bitfields. The bus interface-related bitfields are described below. Not all bitfields referred to in section 9.4, [Programming Information](#), are listed here. To locate a particular bitfield description within this manual, refer to Appendix B, [Register Information](#).

Software_Reset

bit: 11 **type:** Write **in:** Joint_Reset_Register **address:** 72

Setting this bit to 1 resets the DAQ-STC and is equivalent to pulsing the RESET pin. Setting this bit to 0 clears the bit and takes the DAQ-STC out of reset. This bit cannot be cleared using windowed mode accesses.

Software_Test

bit: 5 **type:** Strobe **in:** Analog_Trigger_Etc_Register **address:** 61

Setting this bit to 1 enables the hardware test mode, which tri-states all the output signals. Setting this bit to 1 is equivalent to bringing the TEXT_IN pin low.

Window_Address

bits: <0..15> **type:** Write **in:** Window_Address_Register **address:** 0

This bitfield contains the register address for windowed mode accesses. To access a register in windowed mode, write the address of the register you want to access into this bitfield. The register whose address you wrote will be mirrored in the Window_Data_Read and Window_Data_Write bitfields. Related bitfields: Window_Data_Read, Window_Data_Write.

Window_Data

bits: <0..15> **type:** Read **in:** Window_Data_Register **address:** 1

bits: <0..15> **type:** Write **in:** Window_Data_Register **address:** 1

Use these bitfields to read or write the value contained in the register whose address is in the Window_Address bitfield. Related bitfield: Window_Address.

Write_Strobe_0

bit: 0 **type:** Strobe **in:** Write_Strobe_0_Register **address:** 82

Writing to this register pulses the WRITE_STROBE0 pin.

Write_Strobe_1

bit: 0 **type:** Strobe **in:** Write_Strobe_1_Register **address:** 83

Writing to this register pulses the WRITE_STROBE1 pin.

Write_Strobe_2

bit: 0 **type:** Strobe **in:** Write_Strobe_2_Register **address:** 84

Writing to this register pulses the WRITE_STROBE2 pin.

Write_Strobe_3

bit: 0 **type:** Strobe **in:** Write_Strobe_3_Register **address:** 85

Writing to this register pulses the WRITE_STROBE3 pin.

9.5 Timing Diagrams

The DAQ-STC is statically configurable for Intel- or Motorola-style bus interfaces, which are adaptable to many others. There are seven address lines for accessing up to 128 read/write registers, which are 16 bits wide. The read timing for the Intel-style bus interface is shown in Figure 9-1, and the write timing is shown in Figure 9-2. The read timing for the Motorola-style bus interface is shown in Figure 9-3, and the write timing is shown in Figure 9-4.

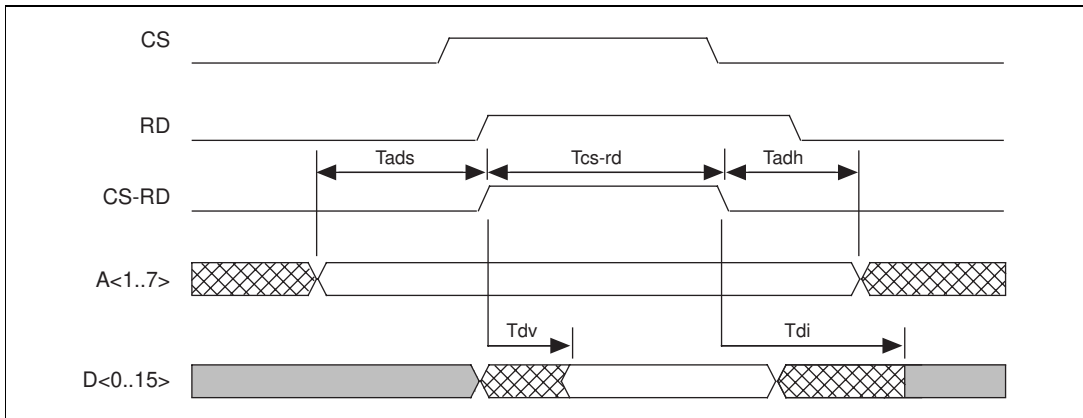

Figure 9-1. Intel Bus Interface Read Timing

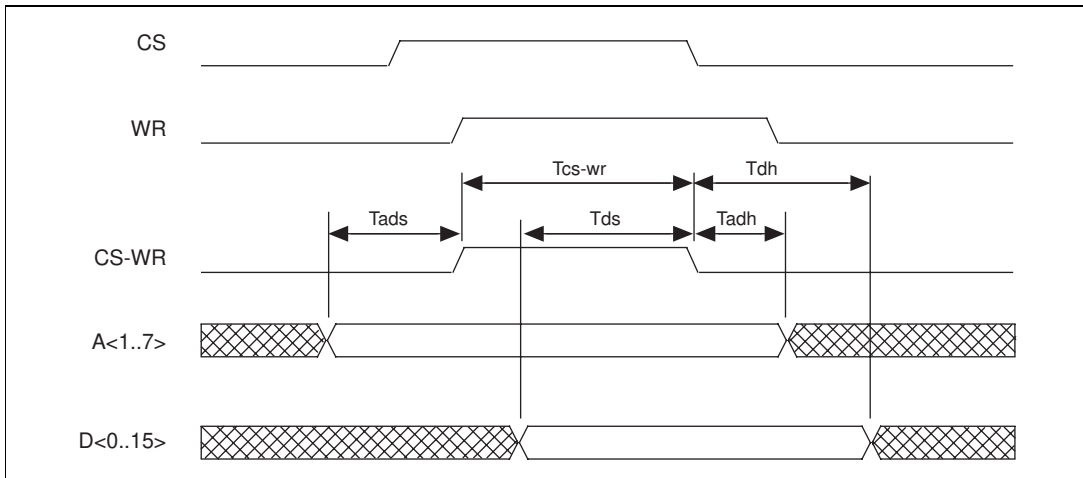

Figure 9-2. Intel Bus Interface Write Timing

Table 9-2. Intel Bus Interface Timing

Name	Description	Minimum	Maximum
Tcs-rd	CS-RD pulsewidth	45 (50)	—
Tcs-wr	CS-WR pulsewidth	40	—
Tads	Address setup time	0	—
Tadh	Address hold time	0	—
Tdv	Data valid	12	44 (49)
Tdi	Data invalid	3	10

Table 9-2. Intel Bus Interface Timing (Continued)

Name	Description	Minimum	Maximum
Tds	Data setup time	25	—
Tdh	Data hold time	0	—

All timing values are in nanoseconds.

The numbers in parentheses indicate a 100 pF load; all other numbers indicate 15 pF.

The DAQ-STC generates an internal read or write signal based upon the read, write, and chip-select signals at the pins. The internal signal will be asserted only when both chip select and the appropriate strobe are asserted, shown in these figures as CS-RD and CS-WR. The timing parameters are all relative to the combined signal.

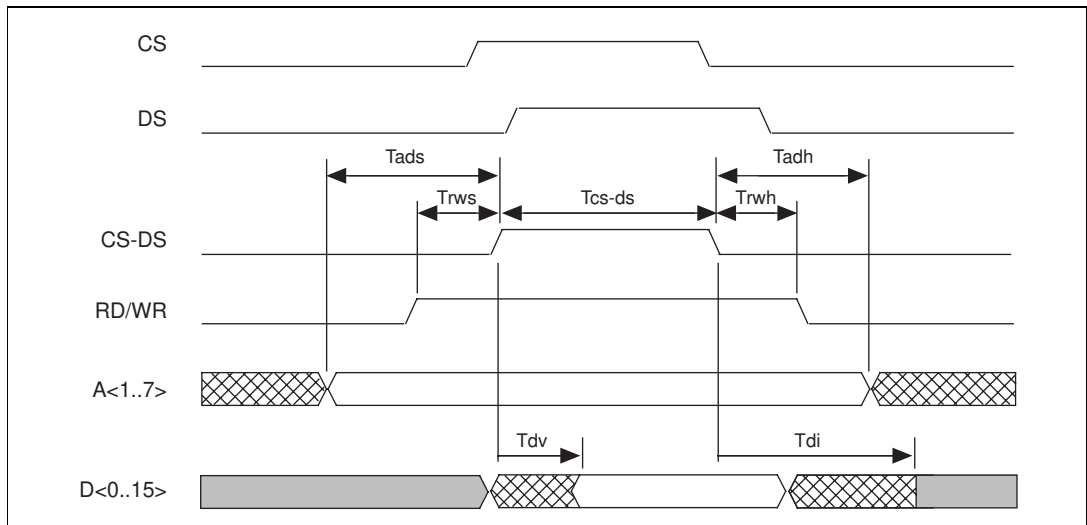
**Figure 9-3.** Motorola Bus Interface Read Timing

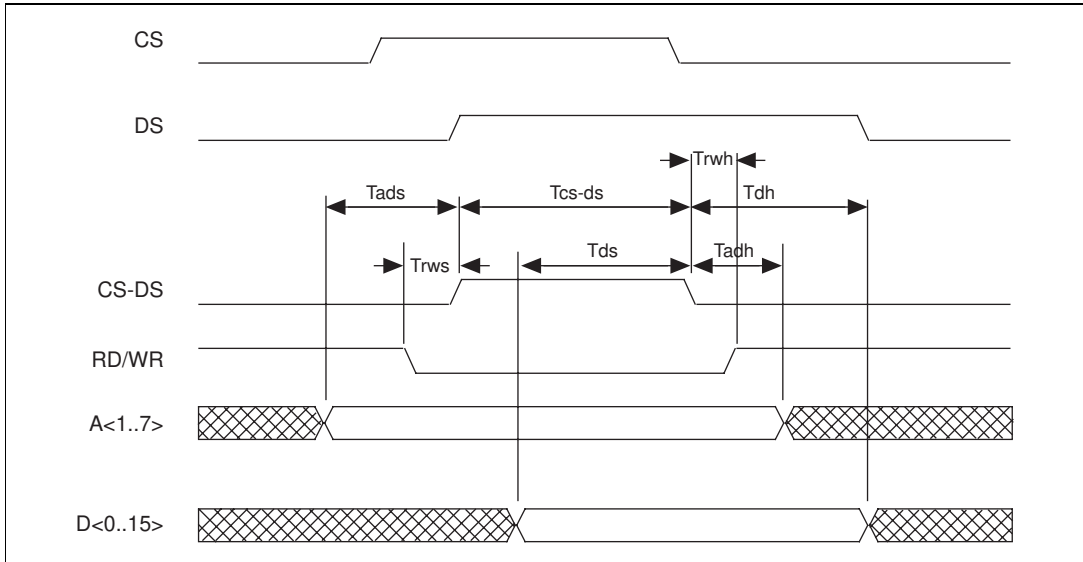

Figure 9-4. Motorola Bus Interface Write Timing

Table 9-3. Intel Bus Interface Timing

Name	Description	Minimum	Maximum
Tcs-ds	CS-DS pulsewidth	50	—
Tads	Address setup time	0	—
Tadh	Address hold time	6	—
Trws	Rd/wr setup time	3	—
Trwh	Rd/wr hold time	3	—
Tdv	Data valid	13	(50)*
Tdi	Data invalid	4	10
Tds	Data setup time	25	—
Tdh	Data hold time	0	—

All timing values are in nanoseconds.
 * Number in parentheses indicates a 100 pF load.

The DAQ-STC generates an internal read or write signal based upon the read/write, data strobe, and chip-select signals at the pins. The internal signals will be asserted only when both the chip-select and data-strobe signals are asserted, shown above as CS-DS. The timing parameters are all relative to the combined signal.

Miscellaneous Functions

10.1 Overview

This chapter discusses the miscellaneous functions not covered in the other chapters. The miscellaneous functions include clock distribution, the programmable frequency output, analog triggering, and test mode. The clock distribution circuit routes the master timebase to each of the internal modules and allows the master timebase to be shared between multiple DAQ-STCs. The programmable frequency output provides a divide-down version of the master timebase for board use. The analog trigger circuit provides an alternate triggering mechanism for the AITM, AOTM, and GPCT that can trigger based on the level of an analog waveform. The test mode provides a method to quickly verify input pin connectivity.

10.2 Features

The DAQ-STC has the following miscellaneous features:

- Clock distribution
 - Two clock input pins for main clock selection with master/slave capability across the RTSI bus
 - Divide-by-two stage for main clock selection allows more flexible interfacing to slow and fast external components
 - Independent clock multiplexers for selecting the input timebase and the output conditioning clock, allowing selection of a fast input timebase for high timing resolution and a slow output conditioning clock to facilitate interfacing to slow components
 - Output pin for board-level use of the main clock selection
- Frequency output
 - Divides the master timebase by any integer between 1 and 16
- Analog trigger
- Test mode

10.3 Clock Distribution

The DAQ-STC has two timing input pins, OSC and RTSI_OSC, to allow for master/slave clock distribution across the RTSI bus, as shown in Figure 10-1. In a master/slave scheme, both master and slave DAQ-STCs derive their timing from the RTSI_OSC pin to minimize the skew between master and slave. The master DAQ-STC enables the output driver on its RTSI_OSC pin and the slave disables the driver on its RTSI_OSC pin. The clock distribution circuit has divisors and multiplexers to divide IN_TIMEBASE by two and select either IN_TIMEBASE or IN_TIMEBASE divided by two for routing to the various modules. This scheme allows using either a 10 MHz or 20 MHz clock at the OSC pin without necessarily scaling the absolute timing. The OUTBRD_OSC pin supplies the IN_TIMEBASE signal to the board either directly or divided by two.

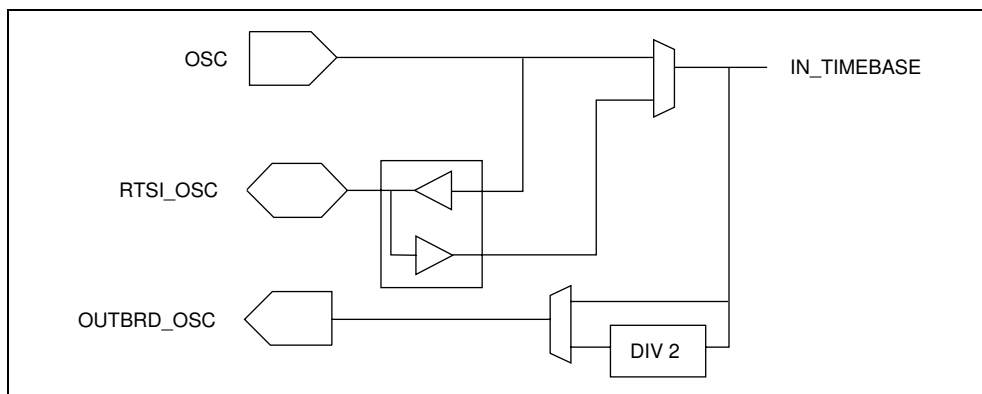

Figure 10-1. Clock Distribution

The clock-distribution circuit generates two input timebases and one output timebase for the AITM, AOTM, and GPCT modules. The slower input timebase, IN_TIMEBASE2, is shared by AITM, AOTM, and GPCT. The multiplexers allow for independent selection of the clock source for the various modules. The multiplexers also provide additional flexibility when interfacing the DAQ-STC to system components because the output portion of the various modules can use a different clock from the input portion of the same module. Table 10-1 indicates the internal timebases derived from IN_TIMEBASE.

Table 10-1. Timebases Derived from IN_TIMEBASE

Timebase	Related Bitfields	Divide Options
IN_TIMEBASE2	Slow_Internal_Time_Divide_By_2, Slow_Internal_Timebase	100, 200
AI_IN_TIMEBASE1	AI_Source_Divide_By_2	1, 2

Table 10-1. Timebases Derived from IN_TIMEBASE (Continued)

Timebase	Related Bitfields	Divide Options
AI_OUT_TIMEBASE	AI_Output_Divide_By_2	1, 2
AO_IN_TIMEBASE1	AO_Source_Divide_By_2	1, 2
AO_OUT_TIMEBASE	AO_Output_Divide_By_2	1, 2
G_IN_TIMEBASE1	G_Source_Divide_By_2	1, 2
FOUT_TIMEBASE	FOUT_Timebase_Select	1, 2
SERIAL_TIMEBASE	DIO_Serial_Out_Divide_By_2, Slow_Internal_Timebase	1, 2

10.4 Frequency Output

The frequency output pin FOUT provides a divide-down version of the master timebase for board use. FOUT can output FOUT_TIMEBASE divided by 1 through 16.

The duty cycle is equal to 50% when the divider setting is 1 or an even number. When the divider is set to an odd number (except 1), the duty cycle is less than 50%. The duty cycle is determined with the following equation $\text{duty cycle} = N/D$, where D = the divider setting and $N = (D-1)/2$. In other words, the output will be high for N time base clocks and low for $N+1$ timebase clocks.

10.5 Analog Trigger

The analog trigger circuit provides a method of triggering the analog input, analog output, or general-purpose counter/timer operation based on the significant instances of an analog waveform. Two voltage references, LOW and HI, are typically available for comparison. External to the DAQ-STC, a comparator tests the analog waveform and generates a digital value indicating whether the analog waveform is below the LOW value or above the HI value. The low-indication and high-indication signals from the comparator are connected directly to the ANALOG_TRIG_IN_LO and ANALOG_TRIG_IN_HI pins, respectively.

When the analog trigger circuit is enabled, the analog trigger signal takes over the PFI0 slot in the PFI input selectors. In this case, the PFI0/AI_START1 pin can no longer be an input, although it can still output the analog input START1 signal.

Many boards will also have the ability to source an analog trigger to external devices based on DAQ-STC timing. The output ANALOG_TRIG_DRIVE selects the I/O direction of the analog trigger signal. You have direct control over ANALOG_TRIG_DRIVE through a bit in the register map.

Figures 10-2 through 10-5 show all of the available modes and illustrations of corresponding trigger generation scenarios. LOW and HI values are represented with dashed lines, and the signal used for triggering is represented with a solid line.

In the low-window mode, the trigger indicates when the signal is less than the LOW value. The HI value is unused.

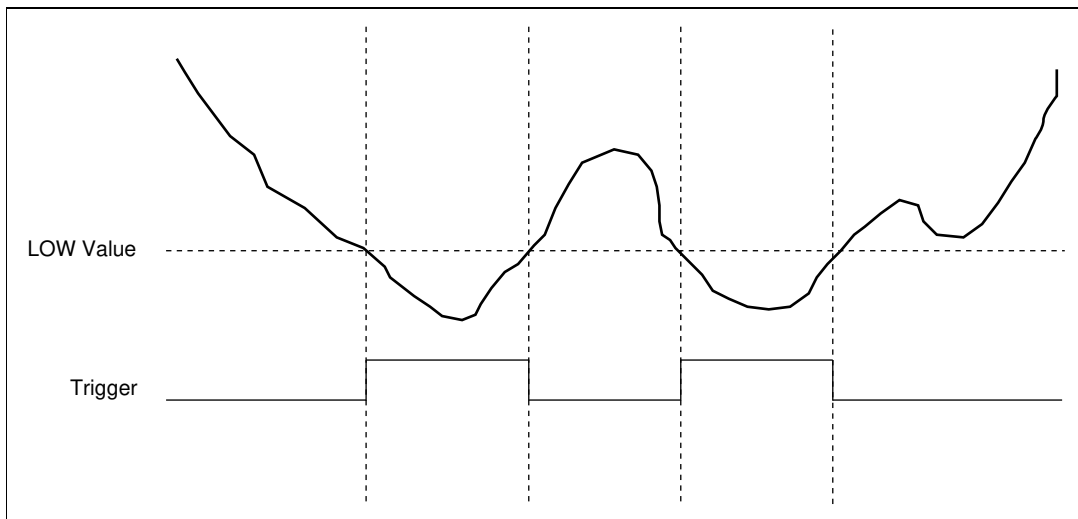

Figure 10-2. Low-Window Mode

In the high-window mode, the trigger indicates when the signal value is greater than the HI value. The LOW value is unused.

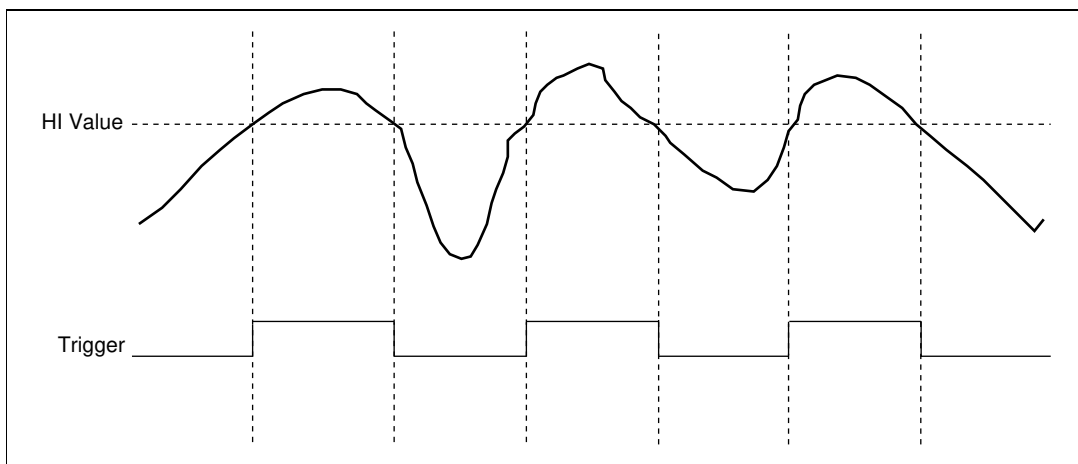

Figure 10-3. High-Window Mode

In the middle-window mode, the trigger indicates when the signal value is between the LOW value and the HI value.

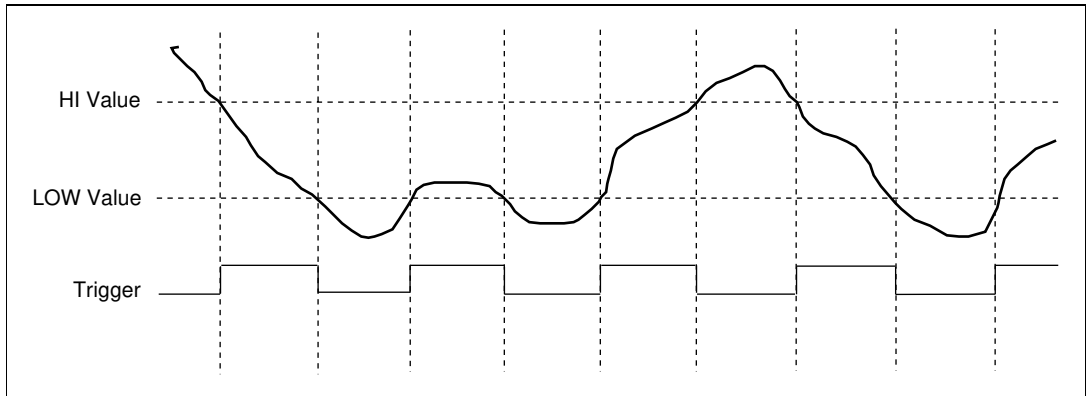

Figure 10-4. Middle-Window Mode

In the high-hysteresis mode, the trigger indicates when the signal value is greater than the HI value, with the hysteresis specified by the LOW value.



Note

To use analog triggering in any of the hysteresis modes, reset the hysteresis register during initialization using one of the analog trigger reset bits.

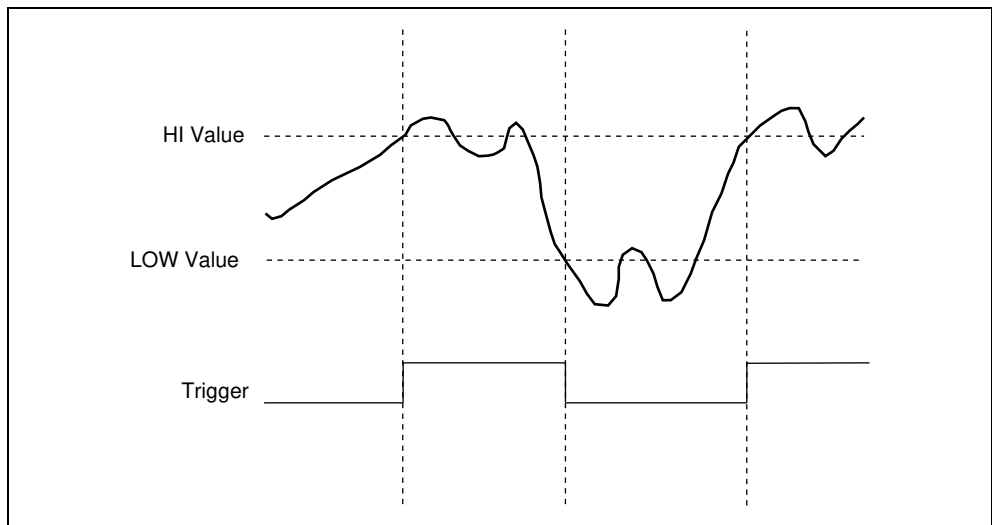

Figure 10-5. High-Hysteresis Mode

In the low-hysteresis mode, the trigger indicates when the signal value is less than the LOW value, with the hysteresis specified by the HI value.

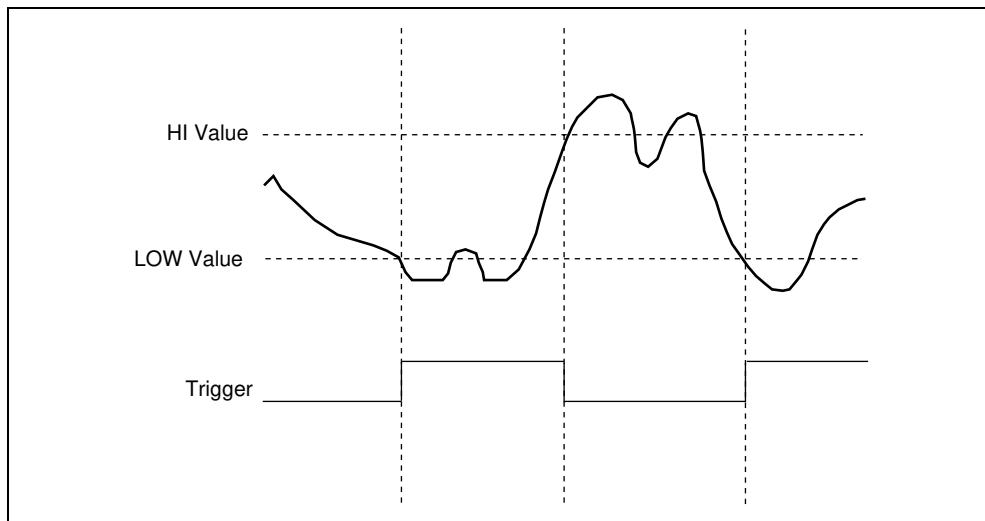

Figure 10-6. Low-Hysteresis Mode

10.6 Test Mode

The DAQ-STC provides an in-circuit test mode to verify connectivity between the board traces and the package pins. Each of the input bidirectional pins is connected to an internal gate tree. The output of the tree appears on the pin TEST_OUT.

The internal gate tree consists of multiple two-input AND gates connected to an OR structure. Figure 10-7 shows the structure of the internal gate tree.

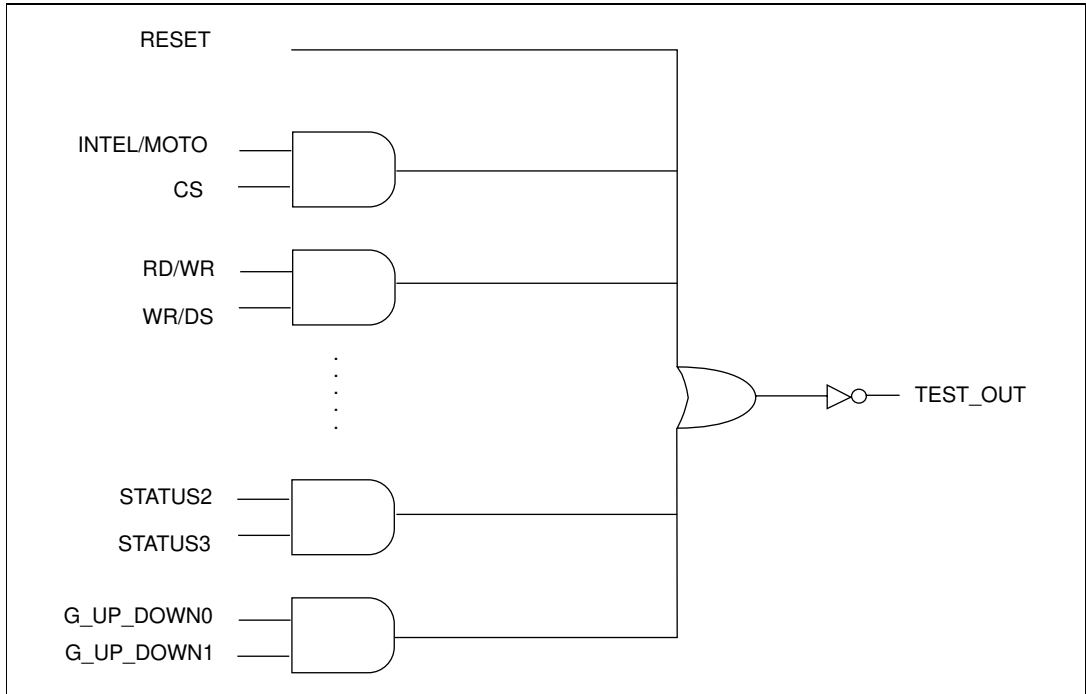

Figure 10-7. Test Mode Internal Gate Tree

To check input pin connectivity using the in-circuit test mode, use the following procedure:

1. Bring TEST_IN high. This setting tri-states all of the output pins except TEST_OUT.
2. Bring the RESET pin and all of the pins listed in Table 10-2 low. TEST_OUT will be high.
3. For each pin pair listed in Table 10-2, perform the following steps:
 - a. Bring both members of the pair high. TEST_OUT will be low.
 - b. Toggle the first member of the pair low, then high. Observe the change on TEST_OUT.
 - c. Toggle the second member of the pair low, then high. Observe the change on TEST_OUT.
 - d. Bring both members of the pair low. TEST_OUT will be high.

The RESET pin is a special case because it connects directly to the OR structure. To test the RESET pin follow these steps:

1. Bring TEST_IN high. This setting tri-states all of the output pins except TEST_OUT.
2. Bring the RESET pin and all of the pins listed in Table 10-2 low. TEST_OUT will be high.
3. Toggle the RESET pin and observe the change on TEST_OUT.

Pins are tested in pairs in the in-circuit test mode. Table 10-2 lists the pin pairs for in-circuit testing.

Table 10-2. Test Mode Input Pin Pairs

Pin Pairs		Pin Pairs	
INTEL/MOTO	CS	RTSI_TRIGGER4	RTSI_TRIGGER5
RD/WR	WR/DS	RTSI_TRIGGER6	GHOST
A1	A2	RTSI_BRD0	RTSI_BRD1
A3	A4	RTSI_BRD2	RTSI_BRD3
A5	A6	EOC	SOC
A7	RTSI_OSC	IRQ_IN0	IRQ_IN1
D0	D1	AIFFF	AIFEF
D2	D3	AIFHF	MUXFEF
D4	D5	AI_STOP_IN	ANALOG_TRIG_IN_LO
D6	D7	ANALOG_IN_TRIG_HI	AOFFF
D8	D9	AOFHF	AOFEF
D10	D11	CPUDACREQ	CHRDY_IN
D12	D13	DIO0/SDOUT	DIO1
D14	D15	DIO2	DIO3
PFI0/AI_START1	PFI1/AI_START2	DIO4/SDIN	DIO5
PFI2/CONV	PFI3/G_SRC1	DIO6	DIO7
PFI4/G_GATE1	PFI5/UPDATE	STATUS0	STATUS1
PFI6/AO_START 1	PFI7/AI_START	STATUS2	STATUS3

Table 10-2. Test Mode Input Pin Pairs (Continued)

Pin Pairs		Pin Pairs	
PFI8/G_SRC0	PFI9/G_GATE0	G_UP_DOWN0	G_UP_DOWN1
RTSI_TRIGGER0	RTSI_TRIGGER1	RTSI_TRIGGER0	RTSI_TRIGGER1
RTSI_TRIGGER2	RTSI_TRIGGER3	RTSI_TRIGGER2	RTSI_TRIGGER3
RTSI_TRIGGER4	RTSI_TRIGGER5	—	—

The G_OUT0/RTSI_OUT, OSC, and TEST_IN pins are not included in the internal gate tree.

10.7 Pin Interface

The I/O signals related to the Miscellaneous Functions are listed in the following table. An asterisk following a pin name indicates that the default polarity for that pin is active low.

Pin Type Notation:

IU	Input, pull up (50 k Ω)
O4TU	Output, 4 mA sink, 2.5 mA source tri-state, pull up (50 k Ω)
IS	Input, TTL Schmitt trigger
O9TU	Output, 9 mA sink, 5 mA source tri-state, pull up (50 k Ω)
O9	Output, 9 mA sink, 5 mA source

Table 10-3. Pin Interface

Pin Name	Type	Description
ANALOG_TRIG_DRIVE	O4TU	Analog Trigger Drive—This pin controls whether the board's trigger line should be output or input. This bit is driven directly from a control register on the DAQ-STC. Related bitfield: Analog_Trigger_Drive.
ANALOG_TRIG_IN_HI	IU	Analog Input Trigger High Voltage Reference—This pin indicates that the analog trigger waveform has exceeded the HI voltage reference. Source: This input is typically fed from an analog comparator on the board.
ANALOG_TRIG_IN_LO	IU	Analog Input Trigger Low Voltage Reference—This pin indicates that the analog trigger waveform has dropped below the LOW voltage reference. Source: This input is typically fed from an analog comparator on the board.

Table 10-3. Pin Interface (Continued)

Pin Name	Type	Description
FOUT	O9TU	Frequency Output—This pin is the frequency divided output. Clock division ratios from 1 to 16 are possible from FOUT_TIMEBASE. Related bitfields: FOUT_Enable, FOUT_Divider, FOUT_Timebase_Select.
OSC	IS	Oscillator Source—OSC is a TTL-compatible clock signal input that is the primary timing source for the DAQ-STC. Maximum frequency is 20 MHz. Related bitfield: RTSI_Clock_Mode.
OUTBRD_OSC	O9TU	Oscillator Source for Output to the Board—This signal is an output to the board and is either RTSI_OSC or OSC depending on whether the internal clock used is OSC or RTSI_OSC. A divide-by-two version of the selected signal can also be output. Related bitfields: Clock_To_Board, RTSI_Clock_Mode, Clock_To_Board_Divide_By_2.
TEST_IN*	IU5	Test Input—This pin invokes the test mode, which tri-states all the output signals except TEST_OUT. It is normally used only for in-circuit testing. During normal operation, the pin should be tied to VDD. Related bitfield: Software_Test.
TEST_OUT	O9	Text Output—This pin is used for in-circuit testing.

10.8 Programming Information

This section presents programming information that is specific to the four miscellaneous functions described in this chapter. For general information about programming the DAQ-STC, see section 2.6, *Programming Information*.

10.8.1 Programming Clock Distribution

You must supply the DAQ-STC with an external frequency source if you want to use any of the functions that depend directly on an internal timebase. Three pins on the DAQ-STC are provided for I/O of this important signal; the pins are listed and described in section 10.3, *Clock Distribution*.

IN_TIMEBASE can be selected from two sources—OSC or RTSI_OSC. If the OSC pin is the IN_TIMEBASE source, the RTSI_OSC pin can be used as the IN-TIMEBASE signal output. The IN_TIMEBASE signal, unmodified or divided down by 2, can be fed to the board by

using the OUTBRD_OSC pin. Boards can use the output of the OUTBRD_OSC pin if a clock synchronous to the one used by the DAQ-STC is needed.

Motivation for the three pins is master/slave operation of boards connected by a RTSI bus. To connect several boards in master/slave fashion, you should not have DAQ-STCs on different boards use different oscillator frequencies as clocks because the oscillators will not be synchronized. To accommodate the master/slave operation, program the DAQ-STCs on the slave boards to input their clock from the RTSI_OSC pins. Program the DAQ-STC on the master board to use the OSC pin as the clock input and to output the clock on the RTSI_OSC pin. If boards are to be used in master/slave mode, they should use the OUTBRD_OSC pin as their local clock source.

When programming the RTSI_OSC pins on several DAQ-STCs, you must program the slave DAQ-STCs *before* the master DAQ-STC.

If the DAQ-STC is supplied with an IN_TIMEBASE signal, you can use an additional, slower, internal timebase, IN_TIMEBASE2. This timebase is obtained by dividing the IN_TIMEBASE frequency by 100 or 200.

If the slow internal timebase is disabled and you select slow internal timebase (IN_TIMEBASE2) for any purpose, you will get a unchanging signal instead of a timebase. You cannot perform hardware-controlled serial digital I/O if the slow internal timebase is disabled.

Use the following function to select the various timebase options.

Function MSC_Clock_Configure

```
{
    Slow_Internal_Timebase = 0 (disable IN_TIMEBASE2 and SERIAL_TIMEBASE) or
                            1 (enable IN_TIMEBASE2 and SERIAL_TIMEBASE);
    Slow_Internal_Time_Divide_By_2 = 0 (do not divide by two) or 1 (divide by two);
    Clock_To_Board = 0 (disable OUTBRD_OSC pin) or 1 (enable OUTBRD_OSC pin);
    Clock_To_Board_Divide_By_2 = 0 (do not divide by two) or 1 (divide by two);
    RTSI_Clock_Mode = 0 (OSC is input) or 1 (OSC is input, RTSI_OSC is output) or
                    2 (slave clock) or 3 (master clock);
}
```



Warning *You must be very careful when programming bidirectional pins for output. If an external signal is driving a bidirectional pin and you configure the pin for output, you may cause physical damage to the DAQ-STC, the external circuitry, or both.*

You must enable the slow internal timebase (IN_TIMEBASE2) if you want to use it.

10.8.2 Programming FOUT

The following function can be used to configure FOUT.

Function `MSC_FOUT_Configure`

```
{
  If (enable FOUT) then
  {
    FOUT_Timebase_Select = 0 (fast timebase) or 1 (slow timebase);
    FOUT_Divider = 0 (divide by 16) or 1 through 15 (divide by 1 through 15);
    FOUT_Enable = 1;
  }
}
```

10.8.3 Programming Analog Trigger

The following function enables or disables analog triggering and, if enabled, selects the analog trigger mode and the source of the analog trigger.

Function `Analog_Trigger_Control`

```
{
  Analog_Trigger_Mode = 0 (low window) or 1 (high window) or 2 (middle window) or
                        3 (high hysteresis) or 6 (low hysteresis);
  Analog_Trigger_Drive = 0 or 1;
  Analog_Trigger_Enable = 0 (not enabled) or 1 (enabled);
}
```

10.8.4 Bitfield Descriptions

Bits in the register bit maps are organized into bitfields. A bitfield can contain one or more bits. Only bits with contiguous locations within a register can belong to a bitfield. The high and low pairs of load and save registers for 24-bit counters are also treated as bitfields. This section describes the bitfields related to the miscellaneous functions. Not all bitfields referred to in section 10.8, *Programming Information*, are listed here. To locate a particular bitfield description within this manual, refer to Appendix B, *Register Information*.

Analog_Trigger_Drive

bit: 4 **type:** Write **in:** `Analog_Trigger_Etc_Register` **address:** 61

This bit controls the `ANALOG_TRIG_DRIVE` output signal:

- 0: Logic low.
- 1: Logic high.

Analog_Trigger_Enable

bit: 3 **type:** Write **in:** Analog_Trigger_Etc_Register **address:** 61

This bit enables the analog trigger circuitry:

- 0: Disabled.
- 1: Enabled.

When the analog trigger circuit is enabled, the analog trigger signal takes over the PFI0 slot in the PFI selectors.

Analog_Trigger_Mode

bits: <0..2> **type:** Write **in:** Analog_Trigger_Etc_Register **address:** 61

This bit selects the analog trigger mode of operation if the analog trigger circuitry is enabled:

- 0: Low window.
- 1: High window.
- 2: Middle window.
- 4: High hysteresis.
- 6: Low hysteresis.

Related bitfield: Analog_Trigger_Enable.

Clock_To_Board

bit: 8 **type:** Write **in:** Clock_and_FOUT_Register **address:** 56

This bit enables the IN_TIMEBASE to feedback or feedthrough to the board through the OUTBRD_OSC pin:

- 0: Disabled.
- 1: Enabled.

Clock_To_Board_Divide_By_2

bit: 9 **type:** Write **in:** Clock_and_FOUT_Register **address:** 56

If the Clock_To_Board bit is set to 1, this bit selects whether IN_TIMEBASE (as selected by the RTSI_Clock_Mode bitfield) will be divided by 2 when it is fed to the board through the OUTBRD_OSC pin.

- 0: Do not divide by 2.
- 1: Divide by 2.

FOUT_Divider

bits: <0..3> **type:** Write **in:** Clock_and_FOUT_Register **address:** 56

This bit selects the divide ratio for the FOUT output signal:

- 0: Divide by 16. $FOUT = FOUT_TIMEBASE$ divided by 16.
- 1-15: Divide by 1-15. $FOUT = FOUT_TIMEBASE$ divided by 1-15.

Related bitfields: FOUT_Timebase_Select, FOUT_Enable.

FOUT_Enable**bit:** 15 **type:** Write **in:** Clock_and_FOUT_Register **address:** 56

Setting this bit to 1 enables and starts frequency output:

- 0: Disabled.
- 1: Enabled.

To change the frequency divider value, first clear this bit, then change FOUT_Divider, and set this bit again. If this bit is clear, FOUT is disabled and output is in the high impedance state.

FOUT_Timebase_Select**bit:** 14 **type:** Write **in:** Clock_and_FOUT_Register **address:** 56

This bit selects the timebase used for FOUT, that is FOUT_TIMEBASE:

- 0: FOUT_TIMEBASE = IN_TIMEBASE if Slow_Internal_Time_Divide_By_2 is 0.
FOUT_TIMEBASE = IN_TIMEBASE/2 if Slow_Internal_Time_Divide_By_2 is 1.
- 1: FOUT_TIMEBASE = IN_TIMEBASE2.

Related bitfield: Slow_Internal_Time_Divide_By_2.

Misc_Counter_TCs_Output_Enable**bit:** 6 **type:** Write **in:** Analog_Trigger_Etc_Register **address:** 61

This bit enables the DIV_TC, SC_TC, SI_TC, UC_TC, and BC_TC output signals:

- 0: Disabled.
- 1: Enabled.

Reserved_One**bit:** 2 **type:** Write **in:** AI_Mode_1_Register **address:** 12

This bit is reserved and always has to be set to 1.

Slow_Internal_Time_Divide_By_2**bit:** 12 **type:** Write **in:** Clock_and_FOUT_Register **address:** 56

This bit determines whether to divide the IN_TIMEBASE2 clock (obtained by dividing the IN_TIMEBASE clock by 100) by 2:

- 0: No.
- 1: Yes.

Slow_Internal_Timebase

bit: 11 **type:** Write **in:** Clock_and_FOUT_Register **address:** 56

This bit enables the slow internal clock (IN_TIMEBASE2) and the clocks used for serial digital output for communication with SCXI (SERIAL_TIMEBASE):

0: Disabled.

1: Enabled.

Specifications

This appendix lists the specifications for the DAQ-STC. These specifications are typical at 25° Celsius unless otherwise noted.

Analog Input

Max sampling rate..... 10 MS/s (single channel)
Max timebase frequency 20 MHz
Min timing resolution..... 50 ns

Analog Output

Number of channels Up to 16
Max update rate..... 4 MS/s (single channel)
Max timebase frequency 20 MHz
Min timing resolution..... 50 ns

General-Purpose Counter/Timers

Number..... 2
Resolution 24 bits
Max source frequency 20 Mhz
Min source pulse duration..... 6 ns
Min gate pulse duration..... 6 ns

Digital I/O

Number of channels 8 I/O
Compatibility TTL in, CMOS out

Frequency Output

Divide ratio1 to 16

Absolute Maximum Ratings

Power supply voltage (V_{DD})-0.5 to +6.5 V

Input/output voltage (V_I/V_O)-0.5 to V_{DD} + 0.5 V

Latch-up current>1 A typ

Output current

Pin Type	Value
O4TU	10 mA
B9TU, O9TU, O9	20 mA
B18TU, OD18U	40 mA

Operating temperature-40 to +85° C

Storage temperature-65 to +150° C

Pin Capacitance

Input capacitance10 pF typ, 25 pF max

Output capacitance10 pF typ, 25 pF max

I/O capacitance10 pF typ, 25 pF max

Recommended Operating Conditions

Power supply voltage (V_{DD})5 V ±5%

Ambient temperature (T_A)0° C min, 70° C max

Low-level input voltage0 V min, 0.8 V max

High-level input voltage2.2 V min, V_{DD} V max

Input rise or fall time0 ns min, 200 ns max

Input rise or fall time,

Schmitt (Buffer Is).....0 ns min, 10 ms max

Positive Schmitt-trigger voltage..... 1.2 V min, 2.4 V max

Negative Schmitt-trigger voltage..... 0.6 V min, 1.8 V max

Hysteresis voltage 0.3 V min, 1.5 V max

DC Characteristics

Quiescent current

($V_I = V_{DD}$ or GND)..... 0.1 μA typ, 400 μA max

Input leakage current (I_L)

Pin Type	Min	Typ	Max	Units
IS ($V_I = V_{DD}$ or GND)		10^{-5}	10	μA
B18TU, B9TU, OD18U, O9TU, O4TU, IU ($V_I = \text{GND}$)	-40	-100	-270	μA
IU5 ($V_I = \text{GND}$)	-0.35	-1.0	-2.2	mA
ID ($V_I = V_{DD}$)	45	120	300	μA

Off-state output leakage current

($V_O = V_{DD}$ or GND)..... 10 μA max

Input clamp voltage

($I_L = 18 \text{ mA}$)..... -1.2 V min

Output short-circuit current

($V_O = 0 \text{ V}$)..... -250 mA min



Note

The rating is for only one output operating in this mode for less than 1 s.

Low-level output current (I_{OL})

($V_{OL} = 0.4 \text{ V}$)

Pin Type	Value
O4TU	4.5 mA min
B9TU, O9TU, O9	9.0 mA min
B18TU, OD18U	24.0 mA min



Note

$V_{DD} = 5 \text{ V} \pm 10\%$, $T_A = -40 \text{ to } +85 \text{ C}$.

High-level output current (I_{OH})
 ($V_{OH} = V_{DD} - 0.4 \text{ V}$)

Pin Type	Value
O4TU	-2.5 mA min
B9TU, O9TU, O9	-5.0 mA min
B18TU	-13.0 mA min

 **Note** $V_{DD} = 5 \text{ V} \pm 10\%$, $T_A = -40 \text{ to } +85 \text{ C}$.

Low-level output voltage (V_{OL})
 ($I_{OL} = 0 \text{ mA}$)0.1 V max

High-level output voltage (V_{OH})
 ($I_{OH} = 0 \text{ mA}$) $V_{DD} - 0.1 \text{ V}$ min

 **Note** $V_{DD} = 5 \text{ V} \pm 10\%$, $T_A = -40 \text{ to } +85 \text{ C}$.

Register Information

This appendix contains information about the DAQ-STC registers and bitfields.



Note *The addresses supplied in the following tables are in terms of 16-bit words. Your DAQ board may access the STC in terms of bytes. For example, AI_Command_2_Register is address 4 in terms of 16-bit words but is address 8 in terms of 8-bit words. Refer to your appropriate RLPM for specific address information.*

Table B-1. DAQ-STC Registers

Register Name	Type	Address	Hex Address
AI_Command_1_Register	Write	8	0x08
AI_Command_2_Register	Write	4	0x04
AI_DIV_Load_A_Register	Write	64	0x40
AI_DIV_Save_Register	Read	26	0x1A
AI_Mode_1_Register	Write	12	0x0C
AI_Mode_2_Register	Write	13	0x0D
AI_Mode_3_Register	Write	87	0x57
AI_Output_Control_Register	Write	60	0x3C
AI_Personal_Register	Write	77	0x4D
AI_SC_Load_A_Registers	Write	18–19	0x12–0x13
AI_SC_Load_B_Registers	Write	20–21	0x14–0x15
AI_SC_Save_Registers	Read	66–67	0x42–43
AI_SI_Load_A_Registers	Write	14–15	0x0E–0x0F
AI_SI_Load_B_Registers	Write	16–17	0x10–0x11
AI_SI_Save_Registers	Read	64–65	0x40–0x41
AI_SI2_Load_A_Register	Write	23	0x17

Table B-1. DAQ-STC Registers (Continued)

Register Name	Type	Address	Hex Address
AI_SI2_Load_B_Register	Write	25	0x19
AI_SI2_Save_Register	Read	25	0x19
AI_START_STOP_Select_Register	Write	62	0x3E
AI_Status_1_Register	Read	2	0x02
AI_Status_2_Register	Read	5	0x05
AI_Trigger_Select_Register	Write	63	0x3F
Analog_Trigger_Etc_Register	Write	61	0x3D
AO_BC_Load_A_Registers	Write	44–45	0x2C–0x2D
AO_BC_Load_B_Registers	Write	46–47	0x2E–0x2F
AO_BC_Save_Registers	Read	18–19	0x12–0x13
AO_Command_1_Register	Write	9	0x09
AO_Command_2_Register	Write	5	0x05
AO_Mode_1_Register	Write	38	0x26
AO_Mode_2_Register	Write	39	0x27
AO_Mode_3_Register	Write	70	0x46
AO_Output_Control_Register	Write	86	0x56
AO_Personal_Register	Write	78	0x4E
AO_START_Select_Register	Write	66	0x42
AO_Status_1_Register	Read	3	0x03
AO_Status_2_Register	Read	6	0x06
AO_Trigger_Select_Register	Write	67	0x43
AO_UC_Load_A_Registers	Write	48–49	0x30–0x31
AO_UC_Load_B_Registers	Write	50–51	0x32–0x33
AO_UC_Save_Registers	Read	20–21	0x14–0x15
AO_UI_Load_A_Registers	Write	40–41	0x28–0x29
AO_UI_Load_B_Registers	Write	42–43	0x2A–0x2B

Table B-1. DAQ-STC Registers (Continued)

Register Name	Type	Address	Hex Address
AO_UI_Save_Registers	Read	16–17	0x10–0x11
AO_UI2_Load_A_Register	Write	53	0x35
AO_UI2_Load_B_Register	Write	55	0x37
AO_UI2_Save_Register	Read	23	0x17
Clock_and_FOUT_Register	Write	56	0x38
DIO_Control_Register	Write	11	0x0B
DIO_Output_Register	Write	10	0x0A
DIO_Parallel_Input_Register	Read	7	0x07
DIO_Serial_Input_Register	Read	28	0x1C
G0_Autoincrement_Register	Write	68	0x44
G0_Command_Register	Write	6	0x06
G0_HW_Save_Registers	Read	8–9	0x08–0x09
G0_Input_Select_Register	Write	36	0x24
G0_Load_A_Registers	Write	28–29	0x1C–0x1D
G0_Load_B_Registers	Write	30–31	0x1E–0x1F
G0_Mode_Register	Write	26	0x1A
G0_Save_Registers	Read	12–13	0x0C–0x0D
G1_Autoincrement_Register	Write	69	0x45
G1_Command_Register	Write	7	0x07
G1_HW_Save_Registers	Read	10–11	0x0A–0x0B
G1_Input_Select_Register	Write	37	0x25
G1_Load_A_Registers	Write	32–33	0x20–0x21
G1_Load_B_Registers	Write	34–35	0x22–0x23
G1_Mode_Register	Write	27	0x1B
G1_Save_Registers	Read	14–15	0x0E–0x0F
Generic_Control_Register	Write	71	0x47

Table B-1. DAQ-STC Registers (Continued)

Register Name	Type	Address	Hex Address
G_Status_Register	Read	4	0x04
Interrupt_A_Ack_Register	Write	2	0x02
Interrupt_A_Enable_Register	Write	73	0x49
Interrupt_B_Ack_Register	Write	3	0x03
Interrupt_B_Enable_Register	Write	75	0x4B
Interrupt_Control_Register	Write	59	0x3B
IO_Bidirection_Pin_Register	Write	57	0x39
Joint_Reset_Register	Write	72	0x48
Joint_Status_1_Register	Read	27	0x1B
Joint_Status_2_Register	Read	29	0x1D
RTSI_Board_Register	Write	81	0x51
RTSI_Trig_A_Output_Register	Write	79	0x4F
RTSI_Trig_B_Output_Register	Write	80	0x50
RTSI_Trig_Direction_Register	Write	58	0x3A
Second_Irq_A_Enable_Register	Write	74	0x4A
Second_Irq_B_Enable_Register	Write	76	0x4C
Window_Address_Register	Write	0	0x00
Window_Data_Read_Register	Read	1	0x01
Window_Data_Write_Register	Write	1	0x01
Write_Strobe_0_Register	Write	82	0x52
Write_Strobe_1_Register	Write	83	0x53
Write_Strobe_2_Register	Write	84	0x54
Write_Strobe_3_Register	Write	85	0x55

Table B-2. Registers in Order of Address*

Address	Register Name
0	Window_Address_Register
1	Window_Data_Write_Register
2	Interrupt_A_Ack_Register
3	Interrupt_B_Ack_Register
4	AI_Command_2_Register
5	AO_Command_2_Register
6	G0_Command_Register
7	G1_Command_Register
8	AI_Command_1_Register
9	AO_Command_1_Register
10	DIO_Output_Register
11	DIO_Control_Register
12	AI_Mode_1_Register
13	AI_Mode_2_Register
14–15	AI_SI_Load_A_Registers
16–17	AI_SI_Load_B_Registers
18–19	AI_SC_Load_A_Registers
20–21	AI_SC_Load_B_Registers
23	AI_SI2_Load_A_Register
25	AI_SI2_Load_B_Register
26	G0_Mode_Register
27	G1_Mode_Register
28–29	G0_Load_A_Registers
30–31	G0_Load_B_Registers
32–33	G1_Load_A_Registers
34–35	G1_Load_B_Registers

Table B-2. Registers in Order of Address* (Continued)

Address	Register Name
36	G0_Input_Select_Register
37	G1_Input_Select_Register
38	AO_Mode_1_Register
39	AO_Mode_2_Register
40–41	AO_UI_Load_A_Registers
42–43	AO_UI_Load_B_Registers
44–45	AO_BC_Load_A_Registers
46–47	AO_BC_Load_B_Registers
48–49	AO_UC_Load_A_Registers
50–51	AO_UC_Load_B_Registers
53	AO_UI2_Load_A_Register
55	AO_UI2_Load_B_Register
56	Clock_and_FOUT_Register
57	IO_Bidirection_Pin_Register
58	RTSI_Trig_Direction_Register
59	Interrupt_Control_Register
60	AI_Output_Control_Register
61	Analog_Trigger_Etc_Register
62	AI_START_STOP_Select_Register
63	AI_Trigger_Select_Register
64	AI_DIV_Load_A_Register
66	AO_START_Select_Register
67	AO_Trigger_Select_Register
68	G0_Autoincrement_Register
69	G1_Autoincrement_Register
70	AO_Mode_3_Register

Table B-2. Registers in Order of Address* (Continued)

Address	Register Name
71	Generic_Control_Register
72	Joint_Reset_Register
73	Interrupt_A_Enable_Register
74	Second_Irq_A_Enable_Register
75	Interrupt_B_Enable_Register
76	Second_Irq_B_Enable_Register
77	AI_Personal_Register
78	AO_Personal_Register
79	RTSI_Trig_A_Output_Register
80	RTSI_Trig_B_Output_Register
81	RTSI_Board_Register
82	Write_Strobe_0_Register
83	Write_Strobe_1_Register
84	Write_Strobe_2_Register
85	Write_Strobe_3_Register
86	AO_Output_Control_Register
87	AI_Mode_3_Register
1	Window_Data_Read_Register
2	AI_Status_1_Register
3	AO_Status_1_Register
4	G_Status_Register
5	AI_Status_2_Register
6	AO_Status_2_Register
7	DIO_Parallel_Input_Register
8–9	G0_HW_Save_Registers
10–11	G1_HW_Save_Registers

Table B-2. Registers in Order of Address* (Continued)

Address	Register Name
12–13	G0_Save_Registers
14–15	G1_Save_Registers
16–17	AO_UI_Save_Registers
18–19	AO_BC_Save_Registers
20–21	AO_UC_Save_Registers
23	AO_UI2_Save_Register
25	AI_SI2_Save_Register
26	AI_DIV_Save_Register
27	Joint_Status_1_Register
28	DIO_Serial_Input_Register
29	Joint_Status_2_Register
64–65	AI_SI_Save_Registers
66–67	AI_SC_Save_Registers
* Write registers are presented in their entirety, followed by read registers.	

Bitfields

Bits in the register bit maps are organized into bitfields. A bitfield can contain one or more bits. Only bits with contiguous locations within a register can belong to a bitfield. The high and low pairs of load and save registers for 24-bit counters are also treated as bitfields. To locate a particular bitfield description within the document, refer to the *Bitfield Descriptions* section of the chapter indicated in Table B-3.

Table B-3. Bitfield Description Guide

Bitfield Prefix	Location in Manual
Analog_Trigger	Chapter 10
BD	Chapter 5
Clock	Chapter 10
Control	Chapter 7
DIO	Chapter 7
AI	Chapter 2
AO	Chapter 3
FOUT	Chapter 10
Gi	Chapter 4
G_Source	Chapter 4
Generic_Status	Chapter 7
Interrupt	Chapter 8
Misc_Counter	Chapter 10
Pass_Thru	Chapter 8
RTSI	Chapter 6
Reserved	Chapter 10
Slow	Chapter 10
Software	Chapter 9
Window	Chapter 9
Write_Strobe	Chapter 9

Register Maps

AI_Command_1_Register

Address: 8 Type: Write-only

15	Reserved
14	AI_Analog_Trigger_Reset
13	AI_Disarm
12	AI_SI2_Arm
11	AI_SI2_Load
10	AI_SI_Arm
9	AI_SI_Load
8	AI_DIV_Arm
7	AI_DIV_Load
6	AI_SC_Arm
5	AI_SC_Load
4	AI_SCAN_IN_PROG_Pulse
3	AI_EXTMUX_CLK_Pulse
2	AI_LOCALMUX_CLK_Pulse
1	AI_SC_TC_Pulse
0	AI_CONVERT_Pulse

AI_Command_2_Register

Address: 4 Type: Write-only

15	AI_End_On_SC_TC
14	AI_End_On_End_Of_Scan
13	Reserved
12	Reserved
11	AI_START1_Disable
10	AI_SC_Save_Trace
9	AI_SI_Switch_Load_On_SC_TC
8	AI_SI_Switch_Load_On_STOP
7	AI_SI_Switch_Load_On_TC
6	Reserved
5	Reserved
4	AI_SC_Switch_Load_On_TC
3	AI_STOP_Pulse
2	AI_START_Pulse
1	AI_START2_Pulse
0	AI_START1_Pulse

AI_DIV_Load_A_Register

Address: 64 Type: Write-only

15	AI_DIV_Load_A
14	AI_DIV_Load_A
13	AI_DIV_Load_A
12	AI_DIV_Load_A
11	AI_DIV_Load_A
10	AI_DIV_Load_A
9	AI_DIV_Load_A
8	AI_DIV_Load_A
7	AI_DIV_Load_A
6	AI_DIV_Load_A
5	AI_DIV_Load_A
4	AI_DIV_Load_A
3	AI_DIV_Load_A
2	AI_DIV_Load_A
1	AI_DIV_Load_A
0	AI_DIV_Load_A

AI_DIV_Save_Register

Address: 26 Type: Read-only

15	AI_DIV_Save_Value
14	AI_DIV_Save_Value
13	AI_DIV_Save_Value
12	AI_DIV_Save_Value
11	AI_DIV_Save_Value
10	AI_DIV_Save_Value
9	AI_DIV_Save_Value
8	AI_DIV_Save_Value
7	AI_DIV_Save_Value
6	AI_DIV_Save_Value
5	AI_DIV_Save_Value
4	AI_DIV_Save_Value
3	AI_DIV_Save_Value
2	AI_DIV_Save_Value
1	AI_DIV_Save_Value
0	AI_DIV_Save_Value

AI_Mode_1_Register

Address: 12 Type: Write-only

15	AI_CONVERT_Source_Select
14	AI_CONVERT_Source_Select
13	AI_CONVERT_Source_Select
12	AI_CONVERT_Source_Select
11	AI_CONVERT_Source_Select
10	AI_SI_Source_Select
9	AI_SI_Source_Select
8	AI_SI_Source_Select
7	AI_SI_Source_Select
6	AI_SI_Source_Select
5	AI_CONVERT_Source_Polarity
4	AI_SI_Source_Polarity
3	AI_Start_Stop
2	Reserved_One
1	AI_Continuous
0	AI_Trigger_Once

AI_Mode_2_Register

Address: 13 Type: Write-only

15	AI_SC_Gate_Enable
14	AI_Start_Stop_Gate_Enable
13	AI_Pre_Trigger
12	AI_External_MUX_Present
11	Reserved
10	Reserved
9	AI_SI2_Initial_Load_Source
8	AI_SI2_Reload_Mode
7	AI_SI_Initial_Load_Source
6	AI_SI_Reload_Mode
5	AI_SI_Reload_Mode
4	AI_SI_Reload_Mode
3	AI_SI_Write_Switch
2	AI_SC_Initial_Load_Source
1	AI_SC_Reload_Mode
0	AI_SC_Write_Switch

AI_Mode_3_Register

Address: 87 Type: Write-only

15	AI_Trigger_Length
14	AI_Delay_START
13	AI_Software_Gate
12	AI_SI_Special_Trigger_Delay
11	AI_SI2_Source_Select
10	AI_Delayed_START2
9	AI_Delayed_START1
8	AI_External_Gate_Mode
7	AI_FIFO_Mode
6	AI_FIFO_Mode
5	AI_External_Gate_Polarity
4	AI_External_Gate_Select
3	AI_External_Gate_Select
2	AI_External_Gate_Select
1	AI_External_Gate_Select
0	AI_External_Gate_Select

AI_Output_Control_Register

Address: 60 Type: Write-only

15	Reserved
14	Reserved
13	Reserved
12	Reserved
11	Reserved
10	AI_START_Output_Select
9	AI_SCAN_IN_PROG_Output_Select
8	AI_SCAN_IN_PROG_Output_Select
7	AI_EXTMUX_CLK_Output_Select
6	AI_EXTMUX_CLK_Output_Select
5	AI_LOCALMUX_CLK_Output_Select
4	AI_LOCALMUX_CLK_Output_Select
3	AI_SC_TC_Output_Select
2	AI_SC_TC_Output_Select
1	AI_CONVERT_Output_Select
0	AI_CONVERT_Output_Select

AI_Personal_Register

Address: 77 Type: Write-only

15	AI_SHIFTIN_Pulse_Width
14	AI_EOC_Polarity
13	AI_SOC_Polarity
12	AI_SHIFTIN_Polarity
11	AI_CONVERT_Pulse_Timebase
10	AI_CONVERT_Pulse_Width
9	AI_CONVERT_Original_Pulse
8	AI_FIFO_Flags_Polarity
7	AI_Overrun_Mode
6	AI_EXTMUX_CLK_Pulse_Width
5	AI_LOCALMUX_CLK_Pulse_Width
4	AI_AIFREQ_Polarity
3	Reserved
2	Reserved
1	Reserved
0	Reserved

AI_SC_Load_A_Registers

Address: 18 Type: Write-only

15	Reserved
14	Reserved
13	Reserved
12	Reserved
11	Reserved
10	Reserved
9	Reserved
8	Reserved
7	AI_SC_Load_A
6	AI_SC_Load_A
5	AI_SC_Load_A
4	AI_SC_Load_A
3	AI_SC_Load_A
2	AI_SC_Load_A
1	AI_SC_Load_A
0	AI_SC_Load_A

AI_SC_Load_A_Registers

Address: 19 Type: Write-only

15	AI_SC_Load_A
14	AI_SC_Load_A
13	AI_SC_Load_A
12	AI_SC_Load_A
11	AI_SC_Load_A
10	AI_SC_Load_A
9	AI_SC_Load_A
8	AI_SC_Load_A
7	AI_SC_Load_A
6	AI_SC_Load_A
5	AI_SC_Load_A
4	AI_SC_Load_A
3	AI_SC_Load_A
2	AI_SC_Load_A
1	AI_SC_Load_A
0	AI_SC_Load_A

AI_SC_Load_B_Registers

Address: 20 Type: Write-only

15	Reserved
14	Reserved
13	Reserved
12	Reserved
11	Reserved
10	Reserved
9	Reserved
8	Reserved
7	AI_SC_Load_B
6	AI_SC_Load_B
5	AI_SC_Load_B
4	AI_SC_Load_B
3	AI_SC_Load_B
2	AI_SC_Load_B
1	AI_SC_Load_B
0	AI_SC_Load_B

AI_SC_Load_B_Registers

Address: 21 Type: Write-only

15	AI_SC_Load_B
14	AI_SC_Load_B
13	AI_SC_Load_B
12	AI_SC_Load_B
11	AI_SC_Load_B
10	AI_SC_Load_B
9	AI_SC_Load_B
8	AI_SC_Load_B
7	AI_SC_Load_B
6	AI_SC_Load_B
5	AI_SC_Load_B
4	AI_SC_Load_B
3	AI_SC_Load_B
2	AI_SC_Load_B
1	AI_SC_Load_B
0	AI_SC_Load_B

AI_SC_Save_Registers

Address: 66 Type: Read-only

15	Reserved
14	Reserved
13	Reserved
12	Reserved
11	Reserved
10	Reserved
9	Reserved
8	Reserved
7	AI_SC_Save_Value
6	AI_SC_Save_Value
5	AI_SC_Save_Value
4	AI_SC_Save_Value
3	AI_SC_Save_Value
2	AI_SC_Save_Value
1	AI_SC_Save_Value
0	AI_SC_Save_Value

AI_SC_Save_Registers

Address: 67 Type: Read-only

15	AI_SC_Save_Value
14	AI_SC_Save_Value
13	AI_SC_Save_Value
12	AI_SC_Save_Value
11	AI_SC_Save_Value
10	AI_SC_Save_Value
9	AI_SC_Save_Value
8	AI_SC_Save_Value
7	AI_SC_Save_Value
6	AI_SC_Save_Value
5	AI_SC_Save_Value
4	AI_SC_Save_Value
3	AI_SC_Save_Value
2	AI_SC_Save_Value
1	AI_SC_Save_Value
0	AI_SC_Save_Value

AI_SI_Load_Registers

Address: 14 Type: Write-only

15	Reserved
14	Reserved
13	Reserved
12	Reserved
11	Reserved
10	Reserved
9	Reserved
8	Reserved
7	AI_SI_Load_A
6	AI_SI_Load_A
5	AI_SI_Load_A
4	AI_SI_Load_A
3	AI_SI_Load_A
2	AI_SI_Load_A
1	AI_SI_Load_A
0	AI_SI_Load_A

AI_SI_Load_A_Registers

Address: 15 Type: Write-only

15	AI_SI_Load_A
14	AI_SI_Load_A
13	AI_SI_Load_A
12	AI_SI_Load_A
11	AI_SI_Load_A
10	AI_SI_Load_A
9	AI_SI_Load_A
8	AI_SI_Load_A
7	AI_SI_Load_A
6	AI_SI_Load_A
5	AI_SI_Load_A
4	AI_SI_Load_A
3	AI_SI_Load_A
2	AI_SI_Load_A
1	AI_SI_Load_A
0	AI_SI_Load_A

AI_SI_Load_B_Registers

Address: 16 Type: Write-only

15	Reserved
14	Reserved
13	Reserved
12	Reserved
11	Reserved
10	Reserved
9	Reserved
8	Reserved
7	AI_SI_Load_B
6	AI_SI_Load_B
5	AI_SI_Load_B
4	AI_SI_Load_B
3	AI_SI_Load_B
2	AI_SI_Load_B
1	AI_SI_Load_B
0	AI_SI_Load_B

AI_SI_Load_B_Registers

Address: 17 Type: Write-only

15	AI_SI_Load_B
14	AI_SI_Load_B
13	AI_SI_Load_B
12	AI_SI_Load_B
11	AI_SI_Load_B
10	AI_SI_Load_B
9	AI_SI_Load_B
8	AI_SI_Load_B
7	AI_SI_Load_B
6	AI_SI_Load_B
5	AI_SI_Load_B
4	AI_SI_Load_B
3	AI_SI_Load_B
2	AI_SI_Load_B
1	AI_SI_Load_B
0	AI_SI_Load_B

AI_SI_Save_Registers

Address: 64 Type: Read-only

15	Reserved
14	Reserved
13	Reserved
12	Reserved
11	Reserved
10	Reserved
9	Reserved
8	Reserved
7	AI_SI_Save_Value
6	AI_SI_Save_Value
5	AI_SI_Save_Value
4	AI_SI_Save_Value
3	AI_SI_Save_Value
2	AI_SI_Save_Value
1	AI_SI_Save_Value
0	AI_SI_Save_Value

AI_SI_Save_Registers

Address: 65 Type: Read-only

15	AI_SI_Save_Value
14	AI_SI_Save_Value
13	AI_SI_Save_Value
12	AI_SI_Save_Value
11	AI_SI_Save_Value
10	AI_SI_Save_Value
9	AI_SI_Save_Value
8	AI_SI_Save_Value
7	AI_SI_Save_Value
6	AI_SI_Save_Value
5	AI_SI_Save_Value
4	AI_SI_Save_Value
3	AI_SI_Save_Value
2	AI_SI_Save_Value
1	AI_SI_Save_Value
0	AI_SI_Save_Value

AI_SI2_Load_A_Register

Address: 23 Type: Write-only

15	AI_SI2_Load_A
14	AI_SI2_Load_A
13	AI_SI2_Load_A
12	AI_SI2_Load_A
11	AI_SI2_Load_A
10	AI_SI2_Load_A
9	AI_SI2_Load_A
8	AI_SI2_Load_A
7	AI_SI2_Load_A
6	AI_SI2_Load_A
5	AI_SI2_Load_A
4	AI_SI2_Load_A
3	AI_SI2_Load_A
2	AI_SI2_Load_A
1	AI_SI2_Load_A
0	AI_SI2_Load_A

AI_SI2_Load_B_Register

Address: 25 Type: Write-only

15	AI_SI2_Load_B
14	AI_SI2_Load_B
13	AI_SI2_Load_B
12	AI_SI2_Load_B
11	AI_SI2_Load_B
10	AI_SI2_Load_B
9	AI_SI2_Load_B
8	AI_SI2_Load_B
7	AI_SI2_Load_B
6	AI_SI2_Load_B
5	AI_SI2_Load_B
4	AI_SI2_Load_B
3	AI_SI2_Load_B
2	AI_SI2_Load_B
1	AI_SI2_Load_B
0	AI_SI2_Load_B

AI_SI2_Save_Register

Address: 25 Type: Read-only

15	AI_SI2_Save_Value
14	AI_SI2_Save_Value
13	AI_SI2_Save_Value
12	AI_SI2_Save_Value
11	AI_SI2_Save_Value
10	AI_SI2_Save_Value
9	AI_SI2_Save_Value
8	AI_SI2_Save_Value
7	AI_SI2_Save_Value
6	AI_SI2_Save_Value
5	AI_SI2_Save_Value
4	AI_SI2_Save_Value
3	AI_SI2_Save_Value
2	AI_SI2_Save_Value
1	AI_SI2_Save_Value
0	AI_SI2_Save_Value

AI_START_STOP_Select_Register

Address: 62 Type: Write-only

15	AI_START_Polarity
14	AI_STOP_Polarity
13	AI_STOP_Sync
12	AI_STOP_Edge
11	AI_STOP_Select
10	AI_STOP_Select
9	AI_STOP_Select
8	AI_STOP_Select
7	AI_STOP_Select
6	AI_START_Sync
5	AI_START_Edge
4	AI_START_Select
3	AI_START_Select
2	AI_START_Select
1	AI_START_Select
0	AI_START_Select

AI_Status_1_Register

Address: 2 Type: Read-only

15	Interrupt_A_St
14	AI_FIFO_Full_St
13	AI_FIFO_Half_Full_St
12	AI_FIFO_Empty_St
11	AI_Overrun_St
10	AI_Overflow_St
9	AI_SC_TC_Error_St
8	AI_START2_St
7	AI_START1_St
6	AI_SC_TC_St
5	AI_START_St
4	AI_STOP_St
3	G0_TC_St
2	G0_Gate_Interrupt_St
1	AI_FIFO_Request_St
0	Pass_Thru_0_Interrupt_St

AI_Status_2_Register

Address: 5 Type: Read-only

15	Reserved_2000_St
14	AI_DIV_Armed_St
13	AI_DIV_Q_St
12	AI_SI2_Next_Load_Source_St
11	AI_SI2_Armed_St
10	AI_SI_Q_St
9	AI_SI_Q_St
8	AI_SI_Count_Enable_St
7	Reserved
6	AI_SI_Next_Load_Source_St
5	AI_SI_Armed_St
4	AI_SC_Q_St
3	AI_SC_Q_St
2	AI_SC_Save_St
1	AI_SC_Next_Load_Source_St
0	AI_SC_Armed_St

AI_Trigger_Select_Register

Address: 63 Type: Write-only

15	AI_START1_Polarity
14	AI_START2_Polarity
13	AI_START2_Sync
12	AI_START2_Edge
11	AI_START2_Select
10	AI_START2_Select
9	AI_START2_Select
8	AI_START2_Select
7	AI_START2_Select
6	AI_START1_Sync
5	AI_START1_Edge
4	AI_START1_Select
3	AI_START1_Select
2	AI_START1_Select
1	AI_START1_Select
0	AI_START1_Select

Analog_Trigger_Etc_Register

Address: 61 Type: Write-only

15	GPFO_1_Output_Enable
14	GPFO_0_Output_Enable
13	GPFO_0_Output_Select
12	GPFO_0_Output_Select
11	GPFO_0_Output_Select
10	Reserved
9	Reserved
8	Reserved
7	GPFO_1_Output_Select
6	Misc_Counter_TCs_Output_Enable
5	Software_Test
4	Analog_Trigger_Drive
3	Analog_Trigger_Enable
2	Analog_Trigger_Mode
1	Analog_Trigger_Mode
0	Analog_Trigger_Mode

AO_BC_Load_A_Registers

Address: 44 Type: Write-only

15	Reserved
14	Reserved
13	Reserved
12	Reserved
11	Reserved
10	Reserved
9	Reserved
8	Reserved
7	AO_BC_Load_A
6	AO_BC_Load_A
5	AO_BC_Load_A
4	AO_BC_Load_A
3	AO_BC_Load_A
2	AO_BC_Load_A
1	AO_BC_Load_A
0	AO_BC_Load_A

AO_BC_Load_A_Registers

Address: 45 Type: Write-only

15	AO_BC_Load_A
14	AO_BC_Load_A
13	AO_BC_Load_A
12	AO_BC_Load_A
11	AO_BC_Load_A
10	AO_BC_Load_A
9	AO_BC_Load_A
8	AO_BC_Load_A
7	AO_BC_Load_A
6	AO_BC_Load_A
5	AO_BC_Load_A
4	AO_BC_Load_A
3	AO_BC_Load_A
2	AO_BC_Load_A
1	AO_BC_Load_A
0	AO_BC_Load_A

AO_BC_Load_B_Registers

Address: 46 Type: Write-only

15	Reserved
14	Reserved
13	Reserved
12	Reserved
11	Reserved
10	Reserved
9	Reserved
8	Reserved
7	AO_BC_Load_B
6	AO_BC_Load_B
5	AO_BC_Load_B
4	AO_BC_Load_B
3	AO_BC_Load_B
2	AO_BC_Load_B
1	AO_BC_Load_B
0	AO_BC_Load_B

AO_BC_Load_B_Registers

Address: 47 Type: Write-only

15	AO_BC_Load_B
14	AO_BC_Load_B
13	AO_BC_Load_B
12	AO_BC_Load_B
11	AO_BC_Load_B
10	AO_BC_Load_B
9	AO_BC_Load_B
8	AO_BC_Load_B
7	AO_BC_Load_B
6	AO_BC_Load_B
5	AO_BC_Load_B
4	AO_BC_Load_B
3	AO_BC_Load_B
2	AO_BC_Load_B
1	AO_BC_Load_B
0	AO_BC_Load_B

AO_BC_Save_Registers

Address: 18 Type: Read-only

15	Reserved
14	Reserved
13	Reserved
12	Reserved
11	Reserved
10	Reserved
9	Reserved
8	Reserved
7	AO_BC_Save_Value
6	AO_BC_Save_Value
5	AO_BC_Save_Value
4	AO_BC_Save_Value
3	AO_BC_Save_Value
2	AO_BC_Save_Value
1	AO_BC_Save_Value
0	AO_BC_Save_Value

AO_BC_Save_Registers

Address: 19 Type: Read-only

15	AO_BC_Save_Value
14	AO_BC_Save_Value
13	AO_BC_Save_Value
12	AO_BC_Save_Value
11	AO_BC_Save_Value
10	AO_BC_Save_Value
9	AO_BC_Save_Value
8	AO_BC_Save_Value
7	AO_BC_Save_Value
6	AO_BC_Save_Value
5	AO_BC_Save_Value
4	AO_BC_Save_Value
3	AO_BC_Save_Value
2	AO_BC_Save_Value
1	AO_BC_Save_Value
0	AO_BC_Save_Value

AO_Command_1_Register

Address: 9 Type: Write-only

15	AO_Analog_Trigger_Reset
14	AO_START_Pulse
13	AO_Disarm
12	AO_UI2_Arm_Disarm
11	AO_UI2_Load
10	AO_UI_Arm
9	AO_UI_Load
8	AO_UC_Arm
7	AO_UC_Load
6	AO_BC_Arm
5	AO_BC_Load
4	AO_DAC1_Update_Mode
3	AO_LDAC1_Source_Select
2	AO_DAC0_Update_Mode
1	AO_LDAC0_Source_Select
0	AO_UPDATE_Pulse

AO_Command_2_Register

Address: 5 Type: Write-only

15	AO_End_On_BC_TC
14	AO_End_On_UC_TC
13	AO_Start_Stop_Gate_Enable
12	AO_UC_Save_Trace
11	AO_BC_Gate_Enable
10	AO_BC_Save_Trace
9	AO_UI_Switch_Load_On_BC_TC
8	AO_UI_Switch_Load_On_Stop
7	AO_UI_Switch_Load_On_TC
6	AO_UC_Switch_Load_On_BC_TC
5	AO_UC_Switch_Load_On_TC
4	AO_BC_Switch_Load_On_TC
3	AO_Mute_B
2	AO_Mute_A
1	AO_UPDATE2_Pulse
0	AO_START1_Pulse

AO_Mode_1_Register

Address: 38 Type: Write-only

15	AO_UPDATE_Source_Select
14	AO_UPDATE_Source_Select
13	AO_UPDATE_Source_Select
12	AO_UPDATE_Source_Select
11	AO_UPDATE_Source_Select
10	AO_UI_Source_Select
9	AO_UI_Source_Select
8	AO_UI_Source_Select
7	AO_UI_Source_Select
6	AO_UI_Source_Select
5	AO_Multiple_Channels
4	AO_UPDATE_Source_Polarity
3	AO_UI_Source_Polarity
2	AO_UC_Switch_Load_Every_TC
1	AO_Continuous
0	AO_Trigger_Once

AO_Mode_2_Register

Address: 39 Type: Write-only

15	AO_FIFO_Mode
14	AO_FIFO_Mode
13	AO_FIFO_Retransmit_Enable
12	AO_START1_Disable
11	AO_UC_Initial_Load_Source
10	AO_UC_Write_Switch
9	AO_UI2_Initial_Load_Source
8	AO_UI2_Reload_Mode
7	AO_UC_Initial_Load_Source
6	AO_UI_Reload_Mode
5	AO_UI_Reload_Mode
4	AO_UI_Reload_Mode
3	AO_UI_Write_Switch
2	AO_BC_Initial_Load_Source
1	AO_BC_Reload_Mode
0	AO_BC_Write_Switch

AO_Mode_3_Register

Address: 70 Type: Write-only

15	Reserved
14	Reserved
13	AO_UI2_Switch_Load_Next_TC
12	AO_UC_Switch_Load_Every_BC_TC
11	AO_Trigger_Length
10	Reserved
9	Reserved
8	Reserved
7	Reserved
6	Reserved
5	AO_Stop_On_Overrun_Error
4	AO_Stop_On_BC_TC_Trigger_Error
3	AO_Stop_On_BC_TC_Error
2	AO_Not_An_UPDATE
1	AO_Software_Gate
0	Reserved

AO_Output_Control_Register

Address: 86 Type: Write-only

15	AO_External_Gate_Enable
14	AO_External_Gate_Select
13	AO_External_Gate_Select
12	AO_External_Gate_Select
11	AO_External_Gate_Select
10	AO_External_Gate_Select
9	AO_Number_Of_Channels
8	AO_Number_Of_Channels
7	AO_Number_Of_Channels
6	AO_Number_Of_Channels
5	AO_UPDATE2_Output_Select
4	AO_UPDATE2_Output_Select
3	AO_External_Gate_Polarity
2	AO_UPDATE2_Output_Toggle
1	AO_UPDATE_Output_Select
0	AO_UPDATE_Output_Select

AO_Personal_Register

Address: 78 Type: Write-only

15	Reserved
14	AO_Number_Of_DAC_Packages
13	AO_Fast_CPU
12	AO_TMRDACWR_Pulse_Width
11	AO_FIFO_Flags_Polarity
10	AO_FIFO_Enable
9	AO_AOFREQ_Polarity
8	AO_DMA_PIO_Control
7	AO_UPDATE_Original_Pulse
6	AO_UPDATE_Pulse_Timebase
5	AO_UPDATE_Pulse_Width
4	AO_BC_Source_Select
3	AO_Interval_Buffer_Mode
2	AO_UPDATE2_Original_Pulse
1	AO_UPDATE2_Pulse_Timebase
0	AO_UPDATE2_Pulse_Width

AO_START_Select_Register

Address: 66 Type: Write-only

15	AO_UI2_Software_Gate
14	AO_UI2_External_Gate_Polarity
13	AO_START_Polarity
12	AO_AOFREQ_Enable
11	AO_UI2_External_Gate_Select
10	AO_UI2_External_Gate_Select
9	AO_UI2_External_Gate_Select
8	AO_UI2_External_Gate_Select
7	AO_UI2_External_Gate_Select
6	AO_START_Sync
5	AO_START_Edge
4	AO_START_Select
3	AO_START_Select
2	AO_START_Select
1	AO_START_Select
0	AO_START_Select

AO_Status_1_Register

Address: 3 Type: Read-only

15	Interrupt_B_St
14	AO_FIFO_Full_St
13	AO_FIFO_Half_Full_St
12	AO_FIFO_Empty_St
11	AO_BC_TC_Error_St
10	AO_START_St
9	AO_Overrun_St
8	AO_START1_St
7	AO_BC_TC_St
6	AO_UC_TC_St
5	AO_UPDATE_St
4	AO_UI2_TC_St
3	G1_TC_St
2	G1_Gate_Interrupt_St
1	AO_FIFO_Request_St
0	Pass_Thru_1_Interrupt_St

AO_Status_2_Register

Address: 6 Type: Read-only

15	AO_UC_Next_Load_Source_St
14	AO_UC_Armed_St
13	AO_UI2_Count_Enable_St
12	AO_UI2_Next_Load_Source_St
11	AO_UI2_Armed_St
10	AO_UI2_TC_Error_St
9	AO_UI_Q_St
8	AO_UI_Count_Enable_St
7	AO_UC_Save_St
6	AO_UI_Next_Load_Source_St
5	AO_UI_Armed_St
4	AO_BC_TC_Trigger_Error_St
3	AO_BC_Q_St
2	AO_BC_Save_St
1	AO_BC_Next_Load_Source_St
0	AO_BC_Armed_St

AO_Trigger_Select_Register

Address: 67 Type: Write-only

15	AO_UI2_External_Gate_Enable
14	AO_Delayed_START1
13	AO_START1_Polarity
12	AO_UI2_Source_Polarity
11	AO_UI2_Source_Select
10	AO_UI2_Source_Select
9	AO_UI2_Source_Select
8	AO_UI2_Source_Select
7	AO_UI2_Source_Select
6	AO_START1_Sync
5	AO_START1_Edge
4	AO_START1_Select
3	AO_START1_Select
2	AO_START1_Select
1	AO_START1_Select
0	AO_START1_Select

AO_UC_Load_A_Registers

Address: 48 Type: Write-only

15	Reserved
14	Reserved
13	Reserved
12	Reserved
11	Reserved
10	Reserved
9	Reserved
8	Reserved
7	AO_UC_Load_A
6	AO_UC_Load_A
5	AO_UC_Load_A
4	AO_UC_Load_A
3	AO_UC_Load_A
2	AO_UC_Load_A
1	AO_UC_Load_A
0	AO_UC_Load_A

AO_UC_Load_A_Registers

Address: 49 Type: Write-only

15	AO_UC_Load_A
14	AO_UC_Load_A
13	AO_UC_Load_A
12	AO_UC_Load_A
11	AO_UC_Load_A
10	AO_UC_Load_A
9	AO_UC_Load_A
8	AO_UC_Load_A
7	AO_UC_Load_A
6	AO_UC_Load_A
5	AO_UC_Load_A
4	AO_UC_Load_A
3	AO_UC_Load_A
2	AO_UC_Load_A
1	AO_UC_Load_A
0	AO_UC_Load_A

AO_UC_Load_B_Registers

Address: 50 Type: Write-only

15	Reserved
14	Reserved
13	Reserved
12	Reserved
11	Reserved
10	Reserved
9	Reserved
8	Reserved
7	AO_UC_Load_B
6	AO_UC_Load_B
5	AO_UC_Load_B
4	AO_UC_Load_B
3	AO_UC_Load_B
2	AO_UC_Load_B
1	AO_UC_Load_B
0	AO_UC_Load_B

AO_UC_Load_B_Registers

Address: 51 Type: Write-only

15	AO_UC_Load_B
14	AO_UC_Load_B
13	AO_UC_Load_B
12	AO_UC_Load_B
11	AO_UC_Load_B
10	AO_UC_Load_B
9	AO_UC_Load_B
8	AO_UC_Load_B
7	AO_UC_Load_B
6	AO_UC_Load_B
5	AO_UC_Load_B
4	AO_UC_Load_B
3	AO_UC_Load_B
2	AO_UC_Load_B
1	AO_UC_Load_B
0	AO_UC_Load_B

AO_UC_Save_Registers

Address: 20 Type: Read-only

15	Reserved
14	Reserved
13	Reserved
12	Reserved
11	Reserved
10	Reserved
9	Reserved
8	Reserved
7	AO_UC_Save_Value
6	AO_UC_Save_Value
5	AO_UC_Save_Value
4	AO_UC_Save_Value
3	AO_UC_Save_Value
2	AO_UC_Save_Value
1	AO_UC_Save_Value
0	AO_UC_Save_Value

AO_UC_Save_Registers

Address: 21 Type: Read-only

15	AO_UC_Save_Value
14	AO_UC_Save_Value
13	AO_UC_Save_Value
12	AO_UC_Save_Value
11	AO_UC_Save_Value
10	AO_UC_Save_Value
9	AO_UC_Save_Value
8	AO_UC_Save_Value
7	AO_UC_Save_Value
6	AO_UC_Save_Value
5	AO_UC_Save_Value
4	AO_UC_Save_Value
3	AO_UC_Save_Value
2	AO_UC_Save_Value
1	AO_UC_Save_Value
0	AO_UC_Save_Value

AO_UI2_Load_A_Register

Address: 53 Type: Write-only

15	AO_UI2_Load_A
14	AO_UI2_Load_A
13	AO_UI2_Load_A
12	AO_UI2_Load_A
11	AO_UI2_Load_A
10	AO_UI2_Load_A
9	AO_UI2_Load_A
8	AO_UI2_Load_A
7	AO_UI2_Load_A
6	AO_UI2_Load_A
5	AO_UI2_Load_A
4	AO_UI2_Load_A
3	AO_UI2_Load_A
2	AO_UI2_Load_A
1	AO_UI2_Load_A
0	AO_UI2_Load_A

AO_UI2_Load_B_Register

Address: 55 Type: Write-only

15	AO_UI2_Load_B
14	AO_UI2_Load_B
13	AO_UI2_Load_B
12	AO_UI2_Load_B
11	AO_UI2_Load_B
10	AO_UI2_Load_B
9	AO_UI2_Load_B
8	AO_UI2_Load_B
7	AO_UI2_Load_B
6	AO_UI2_Load_B
5	AO_UI2_Load_B
4	AO_UI2_Load_B
3	AO_UI2_Load_B
2	AO_UI2_Load_B
1	AO_UI2_Load_B
0	AO_UI2_Load_B

AO_UI2_Save_Register

Address: 23 Type: Read-only

15	AO_UI2_Save_Value
14	AO_UI2_Save_Value
13	AO_UI2_Save_Value
12	AO_UI2_Save_Value
11	AO_UI2_Save_Value
10	AO_UI2_Save_Value
9	AO_UI2_Save_Value
8	AO_UI2_Save_Value
7	AO_UI2_Save_Value
6	AO_UI2_Save_Value
5	AO_UI2_Save_Value
4	AO_UI2_Save_Value
3	AO_UI2_Save_Value
2	AO_UI2_Save_Value
1	AO_UI2_Save_Value
0	AO_UI2_Save_Value

AO_UI_Load_A_Registers

Address: 40 Type: Write-only

15	Reserved
14	Reserved
13	Reserved
12	Reserved
11	Reserved
10	Reserved
9	Reserved
8	Reserved
7	AO_UI_Load_A
6	AO_UI_Load_A
5	AO_UI_Load_A
4	AO_UI_Load_A
3	AO_UI_Load_A
2	AO_UI_Load_A
1	AO_UI_Load_A
0	AO_UI_Load_A

AO_UI_Load_A_Registers

Address: 40 Type: Write-only

15	AO_UI_Load_A
14	AO_UI_Load_A
13	AO_UI_Load_A
12	AO_UI_Load_A
11	AO_UI_Load_A
10	AO_UI_Load_A
9	AO_UI_Load_A
8	AO_UI_Load_A
7	AO_UI_Load_A
6	AO_UI_Load_A
5	AO_UI_Load_A
4	AO_UI_Load_A
3	AO_UI_Load_A
2	AO_UI_Load_A
1	AO_UI_Load_A
0	AO_UI_Load_A

AO_UI_Load_B_Registers

Address: 42 Type: Write-only

15	Reserved
14	Reserved
13	Reserved
12	Reserved
11	Reserved
10	Reserved
9	Reserved
8	Reserved
7	AO_UI_Load_B
6	AO_UI_Load_B
5	AO_UI_Load_B
4	AO_UI_Load_B
3	AO_UI_Load_B
2	AO_UI_Load_B
1	AO_UI_Load_B
0	AO_UI_Load_B

AO_UI_Load_B_Registers

Address: 43 Type: Write-only

15	AO_UI_Load_B
14	AO_UI_Load_B
13	AO_UI_Load_B
12	AO_UI_Load_B
11	AO_UI_Load_B
10	AO_UI_Load_B
9	AO_UI_Load_B
8	AO_UI_Load_B
7	AO_UI_Load_B
6	AO_UI_Load_B
5	AO_UI_Load_B
4	AO_UI_Load_B
3	AO_UI_Load_B
2	AO_UI_Load_B
1	AO_UI_Load_B
0	AO_UI_Load_B

AO_UI_Save_Registers

Address: 16 Type: Read-only

15	Reserved
14	Reserved
13	Reserved
12	Reserved
11	Reserved
10	Reserved
9	Reserved
8	Reserved
7	AO_UI_Save_Value
6	AO_UI_Save_Value
5	AO_UI_Save_Value
4	AO_UI_Save_Value
3	AO_UI_Save_Value
2	AO_UI_Save_Value
1	AO_UI_Save_Value
0	AO_UI_Save_Value

AO_UI_Save_Registers

Address: 17 Type: Read-only

15	AO_UI_Save_Value
14	AO_UI_Save_Value
13	AO_UI_Save_Value
12	AO_UI_Save_Value
11	AO_UI_Save_Value
10	AO_UI_Save_Value
9	AO_UI_Save_Value
8	AO_UI_Save_Value
7	AO_UI_Save_Value
6	AO_UI_Save_Value
5	AO_UI_Save_Value
4	AO_UI_Save_Value
3	AO_UI_Save_Value
2	AO_UI_Save_Value
1	AO_UI_Save_Value
0	AO_UI_Save_Value

Clock_and_FOUT_Register

Address: 56 Type: Write-only

15	FOUT_Enable
14	FOUT_Timebase_Select
13	DIO_Serial_Out_Divide_By_2
12	Slow_Internal_Time_Divide_By_2
11	Slow_Internal_Timebase
10	G_Source_Divide_By_2
9	Clock_To_Board_Divide_By_2
8	Clock_To_Board
7	AI_Output_Divide_By_2
6	AI_Source_Divide_By_2
5	AO_Output_Divide_By_2
4	AO_Source_Divide_By_2
3	FOUT_Divider
2	FOUT_Divider
1	FOUT_Divider
0	FOUT_Divider

DIO_Control_Register

Address: 11 Type: Write-only

15	Reserved
14	Reserved
13	Reserved
12	Reserved
11	DIO_Software_Serial_Control
10	DIO_HW_Serial_Timebase
9	DIO_HW_Serial_Enable
8	DIO_HW_Serial_Start
7	DIO_Pins_Dir
6	DIO_Pins_Dir
5	DIO_Pins_Dir
4	DIO_Pins_Dir
3	DIO_Pins_Dir
2	DIO_Pins_Dir
1	DIO_Pins_Dir
0	DIO_Pins_Dir

DIO_Output_Register

Address: 10 Type: Write-only

15	DIO_Serial_Data_Out
14	DIO_Serial_Data_Out
13	DIO_Serial_Data_Out
12	DIO_Serial_Data_Out
11	DIO_Serial_Data_Out
10	DIO_Serial_Data_Out
9	DIO_Serial_Data_Out
8	DIO_Serial_Data_Out
7	DIO_Parallel_Data_Out
6	DIO_Parallel_Data_Out
5	DIO_Parallel_Data_Out
4	DIO_Parallel_Data_Out
3	DIO_Parallel_Data_Out
2	DIO_Parallel_Data_Out
1	DIO_Parallel_Data_Out
0	DIO_Parallel_Data_Out

DIO_Parallel_Input_Register

Address: 7 Type: Read-only

15	Reserved_1_St
14	Reserved_1_St
13	Reserved_1_St
12	Reserved_1_St
11	Reserved_1_St
10	Reserved_1_St
9	Reserved_1_St
8	Reserved_1_St
7	DIO_Parallel_Data_In_St
6	DIO_Parallel_Data_In_St
5	DIO_Parallel_Data_In_St
4	DIO_Parallel_Data_In_St
3	DIO_Parallel_Data_In_St
2	DIO_Parallel_Data_In_St
1	DIO_Parallel_Data_In_St
0	DIO_Parallel_Data_In_St

DIO_Serial_Input_Register

Address: 28 Type: Read-only

15	Reserved_2_St
14	Reserved_2_St
13	Reserved_2_St
12	Reserved_2_St
11	Reserved_2_St
10	Reserved_2_St
9	Reserved_2_St
8	Reserved_2_St
7	DIO_Serial_Data_In_St
6	DIO_Serial_Data_In_St
5	DIO_Serial_Data_In_St
4	DIO_Serial_Data_In_St
3	DIO_Serial_Data_In_St
2	DIO_Serial_Data_In_St
1	DIO_Serial_Data_In_St
0	DIO_Serial_Data_In_St

G0_Autoincrement_Register

Address: 68 Type: Write-only

15	Reserved
14	Reserved
13	Reserved
12	Reserved
11	Reserved
10	Reserved
9	Reserved
8	Reserved
7	G0_Autoincrement
6	G0_Autoincrement
5	G0_Autoincrement
4	G0_Autoincrement
3	G0_Autoincrement
2	G0_Autoincrement
1	G0_Autoincrement
0	G0_Autoincrement

G0_Command_Register

Address: 6 Type: Write-only

15	G1_Disarm_Copy
14	G1_Save_Trace_Copy
13	G1_Arm_Copy
12	G0_Bank_Switch_Enable
11	G0_Bank_Switch_Mode
10	G0_Bank_Switch_Start
9	G0_Little_Big_Endian
8	G0_Synchronized_Gate
7	G0_Write_Switch
6	G0_Up_Down
5	G0_Up_Down
4	G0_Disarm
3	G0_Analog_Trigger_Reset
2	G0_Load
1	G0_Save_Trace
0	G0_Arm

G0_HW_Save_Registers

Address: 8 Type: Read-only

15	Reserved
14	Reserved
13	Reserved
12	Reserved
11	Reserved
10	Reserved
9	Reserved
8	Reserved
7	G0_HW_Save_Value
6	G0_HW_Save_Value
5	G0_HW_Save_Value
4	G0_HW_Save_Value
3	G0_HW_Save_Value
2	G0_HW_Save_Value
1	G0_HW_Save_Value
0	G0_HW_Save_Value

G0_HW_Save_Registers

Address: 9 Type: Read-only

15	G0_HW_Save_Value
14	G0_HW_Save_Value
13	G0_HW_Save_Value
12	G0_HW_Save_Value
11	G0_HW_Save_Value
10	G0_HW_Save_Value
9	G0_HW_Save_Value
8	G0_HW_Save_Value
7	G0_HW_Save_Value
6	G0_HW_Save_Value
5	G0_HW_Save_Value
4	G0_HW_Save_Value
3	G0_HW_Save_Value
2	G0_HW_Save_Value
1	G0_HW_Save_Value
0	G0_HW_Save_Value

G0_Input_Select_Register

Address: 36 Type: Write-only

15	G0_Source_Polarity
14	G0_Output_Polarity
13	G0_OR_Gate
12	G0_Gate_Select_Load_Source
11	G0_Gate_Select
10	G0_Gate_Select
9	G0_Gate_Select
8	G0_Gate_Select
7	G0_Gate_Select
6	G0_Source_Select
5	G0_Source_Select
4	G0_Source_Select
3	G0_Source_Select
2	G0_Source_Select
1	G0_Write_Acknowledges_Irq
0	G0_Read_Acknowledges_Irq

G0_Load_A_Registers

Address: 28 Type: Write-only

15	Reserved
14	Reserved
13	Reserved
12	Reserved
11	Reserved
10	Reserved
9	Reserved
8	Reserved
7	G0_Load_A
6	G0_Load_A
5	G0_Load_A
4	G0_Load_A
3	G0_Load_A
2	G0_Load_A
1	G0_Load_A
0	G0_Load_A

G0_Load_A_Registers

Address: 29 Type: Write-only

15	G0_Load_A
14	G0_Load_A
13	G0_Load_A
12	G0_Load_A
11	G0_Load_A
10	G0_Load_A
9	G0_Load_A
8	G0_Load_A
7	G0_Load_A
6	G0_Load_A
5	G0_Load_A
4	G0_Load_A
3	G0_Load_A
2	G0_Load_A
1	G0_Load_A
0	G0_Load_A

G0_Load_B_Registers

Address: 30 Type: Write-only

15	Reserved
14	Reserved
13	Reserved
12	Reserved
11	Reserved
10	Reserved
9	Reserved
8	Reserved
7	G0_Load_B
6	G0_Load_B
5	G0_Load_B
4	G0_Load_B
3	G0_Load_B
2	G0_Load_B
1	G0_Load_B
0	G0_Load_B

G0_Load_B_Registers

Address: 31 Type: Write-only

15	G0_Load_B
14	G0_Load_B
13	G0_Load_B
12	G0_Load_B
11	G0_Load_B
10	G0_Load_B
9	G0_Load_B
8	G0_Load_B
7	G0_Load_B
6	G0_Load_B
5	G0_Load_B
4	G0_Load_B
3	G0_Load_B
2	G0_Load_B
1	G0_Load_B
0	G0_Load_B

G0_Mode_Register

Address: 26 Type: Write-only

15	G0_Reload_Source_Switching
14	G0_Loading_On_Gate
13	G0_Gate_Polarity
12	G0_Loading_On_TC
11	G0_Counting_Once
10	G0_Counting_Once
9	G0_Output_Mode
8	G0_Output_Mode
7	G0_Load_Source_Select
6	G0_Stop_Mode
5	G0_Stop_Mode
4	G0_Trigger_Mode_For_Edge_Gate
3	G0_Trigger_Mode_For_Edge_Gate
2	G0_Gate_On_Both_Edges
1	G0_Gating_Mode
0	G0_Gating_Mode

G0_Save_Registers

Address: 12 Type: Read-only

15	Reserved
14	Reserved
13	Reserved
12	Reserved
11	Reserved
10	Reserved
9	Reserved
8	Reserved
7	G0_Save_Value
6	G0_Save_Value
5	G0_Save_Value
4	G0_Save_Value
3	G0_Save_Value
2	G0_Save_Value
1	G0_Save_Value
0	G0_Save_Value

G0_Save_Registers

Address: 13 Type: Read-only

15	G0_Save_Value
14	G0_Save_Value
13	G0_Save_Value
12	G0_Save_Value
11	G0_Save_Value
10	G0_Save_Value
9	G0_Save_Value
8	G0_Save_Value
7	G0_Save_Value
6	G0_Save_Value
5	G0_Save_Value
4	G0_Save_Value
3	G0_Save_Value
2	G0_Save_Value
1	G0_Save_Value
0	G0_Save_Value

G1_Autoincrement_Register

Address: 69 Type: Write-only

15	Reserved
14	Reserved
13	Reserved
12	Reserved
11	Reserved
10	Reserved
9	Reserved
8	Reserved
7	G1_Autoincrement
6	G1_Autoincrement
5	G1_Autoincrement
4	G1_Autoincrement
3	G1_Autoincrement
2	G1_Autoincrement
1	G1_Autoincrement
0	G1_Autoincrement

G1_Command_Register

Address: 7 Type: Write-only

15	G0_Disarm_Copy
14	G0_Save_Trace_Copy
13	G0_Arm_Copy
12	G1_Bank_Switch_Enable
11	G1_Bank_Switch_Mode
10	G1_Bank_Switch_Start
9	G1_Little_Big_Endian
8	G1_Synchronized_Gate
7	G1_Write_Switch
6	G1_Up_Down
5	G1_Up_Down
4	G1_Disarm
3	G1_Analog_Trigger_Reset
2	G1_Load
1	G1_Save_Trace
0	G1_Arm

G1_HW_Save_Registers

Address: 10 Type: Read-only

15	Reserved
14	Reserved
13	Reserved
12	Reserved
11	Reserved
10	Reserved
9	Reserved
8	Reserved
7	G1_GW_Save_Value
6	G1_GW_Save_Value
5	G1_GW_Save_Value
4	G1_GW_Save_Value
3	G1_GW_Save_Value
2	G1_GW_Save_Value
1	G1_GW_Save_Value
0	G1_GW_Save_Value

G1_HW_Save_Registers

Address: 11 Type: Read-only

15	G1_GW_Save_Value
14	G1_GW_Save_Value
13	G1_GW_Save_Value
12	G1_GW_Save_Value
11	G1_GW_Save_Value
10	G1_GW_Save_Value
9	G1_GW_Save_Value
8	G1_GW_Save_Value
7	G1_GW_Save_Value
6	G1_GW_Save_Value
5	G1_GW_Save_Value
4	G1_GW_Save_Value
3	G1_GW_Save_Value
2	G1_GW_Save_Value
1	G1_GW_Save_Value
0	G1_GW_Save_Value

G1_Input_Select_Register

Address: 37 Type: Write-only

15	G1_Source_Polarity
14	G1_Output_Polarity
13	G1_OR_Gate
12	G1_Gate_Select_Load_Source
11	G1_Gate_Select
10	G1_Gate_Select
9	G1_Gate_Select
8	G1_Gate_Select
7	G1_Gate_Select
6	G1_Source_Select
5	G1_Source_Select
4	G1_Source_Select
3	G1_Source_Select
2	G1_Source_Select
1	G1_Write_Acknowledges_Irq
0	G1_Read_Acknowledges_Irq

G1_Load_A_Registers

Address: 32 Type: Write-only

15	Reserved
14	Reserved
13	Reserved
12	Reserved
11	Reserved
10	Reserved
9	Reserved
8	Reserved
7	G1_Load_A
6	G1_Load_A
5	G1_Load_A
4	G1_Load_A
3	G1_Load_A
2	G1_Load_A
1	G1_Load_A
0	G1_Load_A

G1_Load_A_Registers

Address: 33 Type: Write-only

15	G1_Load_A
14	G1_Load_A
13	G1_Load_A
12	G1_Load_A
11	G1_Load_A
10	G1_Load_A
9	G1_Load_A
8	G1_Load_A
7	G1_Load_A
6	G1_Load_A
5	G1_Load_A
4	G1_Load_A
3	G1_Load_A
2	G1_Load_A
1	G1_Load_A
0	G1_Load_A

G1_Load_B_Registers

Address: 34 Type: Write-only

15	Reserved
14	Reserved
13	Reserved
12	Reserved
11	Reserved
10	Reserved
9	Reserved
8	Reserved
7	G1_Load_B
6	G1_Load_B
5	G1_Load_B
4	G1_Load_B
3	G1_Load_B
2	G1_Load_B
1	G1_Load_B
0	G1_Load_B

G1_Load_B_Registers

Address: 35 Type: Write-only

15	G1_Load_B
14	G1_Load_B
13	G1_Load_B
12	G1_Load_B
11	G1_Load_B
10	G1_Load_B
9	G1_Load_B
8	G1_Load_B
7	G1_Load_B
6	G1_Load_B
5	G1_Load_B
4	G1_Load_B
3	G1_Load_B
2	G1_Load_B
1	G1_Load_B
0	G1_Load_B

G1_Mode_Register

Address: 27 Type: Write-only

15	G1_Reload_Source_Switching
14	G1_Loading_On_Gate
13	G1_Gate_Polarity
12	G1_Loading_On_TC
11	G1_Counting_Once
10	G1_Counting_Once
9	G1_Output_Mode
8	G1_Output_Mode
7	G1_Load_Source_Select
6	G1_Stop_Mode
5	G1_Stop_Mode
4	G1_Trigger_Mode_For_Edge_Gate
3	G1_Trigger_Mode_For_Edge_Gate
2	G1_Gate_On_Both_Edges
1	G1_Gating_Mode
0	G1_Gating_Mode

G1_Save_Registers

Address: 14 Type: Read-only

15	Reserved
14	Reserved
13	Reserved
12	Reserved
11	Reserved
10	Reserved
9	Reserved
8	Reserved
7	G1_Save_Value
6	G1_Save_Value
5	G1_Save_Value
4	G1_Save_Value
3	G1_Save_Value
2	G1_Save_Value
1	G1_Save_Value
0	G1_Save_Value

G1_Save_Registers

Address: 15 Type: Read-only

15	G1_Save_Value
14	G1_Save_Value
13	G1_Save_Value
12	G1_Save_Value
11	G1_Save_Value
10	G1_Save_Value
9	G1_Save_Value
8	G1_Save_Value
7	G1_Save_Value
6	G1_Save_Value
5	G1_Save_Value
4	G1_Save_Value
3	G1_Save_Value
2	G1_Save_Value
1	G1_Save_Value
0	G1_Save_Value

G_Status_Register

Address: 4 Type: Read-only

15	G1_Gate_Error_St
14	G0_Gate_Error_St
13	G1_TC_Error_St
12	G0_TC_Error_St
11	G1_No_Load_Between_Gates_St
10	G0_No_Load_Between_Gates_St
9	G1_Armed_St
8	G0_Armed_St
7	G1_Stale_Data_St
6	G0_Stale_Data_St
5	G1_Next_Load_Source_St
4	G0_Next_Load_Source_St
3	G1_Counting_St
2	G0_Counting_St
1	G1_Save_St
0	G0_Save_St

Generic_Control_Register

Address: 71 Type: Write-only

15	Control
14	Control
13	Control
12	Control
11	Control
10	Control
9	Control
8	Control
7	Reserved
6	Reserved
5	Reserved
4	Reserved
3	Reserved
2	Reserved
1	Reserved
0	Reserved

Interrupt_A_Ack_Register

Address: 2 Type: Write-only

15	G0_Gate_Interrupt_Ack
14	G0_TC_Interrupt_Ack
13	AI_Error_Interrupt_Ack
12	AI_STOP_Interrupt_Ack
11	AI_START_Interrupt_Ack
10	AI_START2_Interrupt_Ack
9	AI_START1_Interrupt_Ack
8	AI_SC_TC_Interrupt_Ack
7	AI_SC_TC_Error_Confirm
6	G0_TC_Error_Confirm
5	G0_Gate_Error_Confirm
4	Reserved
3	Reserved
2	Reserved
1	Reserved
0	Reserved

Interrupt_A_Enable_Register

Address: 73 Type: Write-only

15	Reserved
14	Reserved
13	Reserved
12	Reserved
11	Reserved
10	Reserved
9	Pass_Thru_0_Interrupt_Enable
8	G0_Gate_Interrupt_Enable
7	AI_FIFO_Interrupt_Enable
6	G0_TC_Interrupt_Enable
5	AI_Error_Interrupt_Enable
4	AI_STOP_Interrupt_Enable
3	AI_START_Interrupt_Enable
2	AI_START2_Interrupt_Enable
1	AI_START1_Interrupt_Enable
0	AI_SC_TC_Interrupt_Enable

Interrupt_B_Ack_Register

Address: 3 Type: Write-only

15	G1_Gate_Interrupt_Ack
14	G1_TC_Interrupt_Ack
13	AO_Error_Interrupt_Ack
12	AO_STOP_Interrupt_Ack
11	AO_START_Interrupt_Ack
10	AO_UPDATE_Interrupt_Ack
9	AO_START1_Interrupt_Ack
8	AO_BC_TC_Interrupt_Ack
7	AO_UC_TC_Interrupt_Ack
6	AO_UI2_TC_Interrupt_Ack
5	AO_UI2_TC_Error_Confirm
4	AO_BC_TC_Error_Confirm
3	AO_BC_TC_Trigger_Error_Confirm
2	G1_TC_Error_Confirm
1	G1_Gate_Error_Confirm
0	Reserved

Interrupt_B_Enable_Register

Address: 75 Type: Write-only

15	Reserved
14	Reserved
13	Reserved
12	Reserved
11	Pass_Thru_1_Interrupt_Enable
10	G1_Gate_Interrupt_Enable
9	G1_TC_Interrupt_Enable
8	AO_FIFO_Interrupt_Enable
7	AO_UI2_TC_Interrupt_Enable
6	AO_UC_TC_Interrupt_Enable
5	AO_Error_Interrupt_Enable
4	AO_STOP_Interrupt_Enable
3	AO_START_Interrupt_Enable
2	AO_UPDATE_Interrupt_Enable
1	AO_START1_Interrupt_Enable
0	AO_BC_TC_Interrupt_Enable

Interrupt_Control_Register

Address: 59 Type: Write-only

15	Interrupt_B_Enable
14	Interrupt_B_Output_Select
13	Interrupt_B_Output_Select
12	Interrupt_B_Output_Select
11	Interrupt_A_Enable
10	Interrupt_A_Output_Select
9	Interrupt_A_Output_Select
8	Interrupt_A_Output_Select
7	Reserved
6	Reserved
5	Reserved
4	Reserved
3	Pass_Thru_0_Interrupt_Polarity
2	Pass_Thru_1_Interrupt_Polarity
1	Interrupt_Output_On_3_Pins
0	Interrupt_Output_Polarity

IO_Bidirection_Pin_Register

Address: 57 Type: Write-only

15	Reserved
14	Reserved
13	Reserved
12	Reserved
11	Reserved
10	Reserved
9	BD_9_Pin_Dir
8	BD_9_Pin_Dir
7	BD_9_Pin_Dir
6	BD_9_Pin_Dir
5	BD_9_Pin_Dir
4	BD_9_Pin_Dir
3	BD_9_Pin_Dir
2	BD_9_Pin_Dir
1	BD_9_Pin_Dir
0	BD_9_Pin_Dir

Joint_Reset_Register

Address: 72 Type: Write-only

15	Reserved
14	Reserved
13	Reserved
12	Reserved
11	Software_Reset
10	AO_UI2_Configuration_End
9	AO_Configuration_End
8	AI_Configuration_End
7	Reserved
6	AO_UI2_Configuration_Start
5	AO_Configuration_Start
4	AI_Configuration_Start
3	G1_Reset
2	G0_Reset
1	AO_Reset
0	AI_Reset

Joint_Status_1_Register

Address: 27 Type: Read-only

15	AI_Last_Shiftin_St
14	AO_UC_Q_St
13	AO_UI2_Gate_St
12	DIO_Serial_IO_In_Progress_St
11	AO_External_Gate_St
10	AI_External_Gate_St
9	AI_SI2_Q_St
8	AI_SI2_Q_St
7	AO_Start_Stop_Gate_St
6	AO_BC_Gate_St
5	AI_Start_Stop_Gate_St
4	AI_SC_Gate_St
3	G1_Gate_St
2	G0_Gate_St
1	G1_Bank_St
0	G0_Bank_St

Joint_Status_2_Register

Address: 29 Type: Read-only

15	G1_Permanent_Stale_Data_St
14	G0_Permanent_Stale_Data_St
13	G1_HW_Save_St
12	G0_HW_Save_St
11	Generic_Status
10	Generic_Status
9	Generic_Status
8	Generic_Status
7	AI_Scan_In_Progress_St
6	AI_Config_Memory_Empty_St
5	AO_TMRDACWRs_In_Progress_St
4	AI_EOC_St
3	AI_SOC_St
2	AO_STOP_St
1	G1_Output_St
0	G0_Output_St

RTSI_Board_Register

Address: 81 Type: Write-only

15	RTSI_Board_3_Pin_Dir
14	RTSI_Board_2_Pin_Dir
13	RTSI_Board_1_Pin_Dir
12	RTSI_Board_0_Pin_Dir
11	RTSI_Board_3_Output_Select
10	RTSI_Board_3_Output_Select
9	RTSI_Board_3_Output_Select
8	RTSI_Board_2_Output_Select
7	RTSI_Board_2_Output_Select
6	RTSI_Board_2_Output_Select
5	RTSI_Board_1_Output_Select
4	RTSI_Board_1_Output_Select
3	RTSI_Board_1_Output_Select
2	RTSI_Board_0_Output_Select
1	RTSI_Board_0_Output_Select
0	RTSI_Board_0_Output_Select

RTSI_Trig_A_Output_Register

Address: 79 Type: Write-only

15	RTSI_Trig_3_Output_Select
14	RTSI_Trig_3_Output_Select
13	RTSI_Trig_3_Output_Select
12	RTSI_Trig_3_Output_Select
11	RTSI_Trig_2_Output_Select
10	RTSI_Trig_2_Output_Select
9	RTSI_Trig_2_Output_Select
8	RTSI_Trig_2_Output_Select
7	RTSI_Trig_1_Output_Select
6	RTSI_Trig_1_Output_Select
5	RTSI_Trig_1_Output_Select
4	RTSI_Trig_1_Output_Select
3	RTSI_Trig_0_Output_Select
2	RTSI_Trig_0_Output_Select
1	RTSI_Trig_0_Output_Select
0	RTSI_Trig_0_Output_Select

RTSI_Trig_B_Output_Register

Address: 80 Type: Write-only

15	RTSI_Sub_Selection_1
14	Reserved
13	Reserved
12	Reserved
11	RTSI_Trig_6_Output_Select
10	RTSI_Trig_6_Output_Select
9	RTSI_Trig_6_Output_Select
8	RTSI_Trig_6_Output_Select
7	RTSI_Trig_5_Output_Select
6	RTSI_Trig_5_Output_Select
5	RTSI_Trig_5_Output_Select
4	RTSI_Trig_5_Output_Select
3	RTSI_Trig_4_Output_Select
2	RTSI_Trig_4_Output_Select
1	RTSI_Trig_4_Output_Select
0	RTSI_Trig_4_Output_Select

RTSI_Trig_Direction_Register

Address: 58 Type: Write-only

15	RTSI_Trig_6_Pin_Dir
14	RTSI_Trig_5_Pin_Dir
13	RTSI_Trig_4_Pin_Dir
12	RTSI_Trig_3_Pin_Dir
11	RTSI_Trig_2_Pin_Dir
10	RTSI_Trig_1_Pin_Dir
9	RTSI_Trig_0_Pin_Dir
8	Reserved
7	Reserved
6	Reserved
5	Reserved
4	Reserved
3	Reserved
2	Reserved
1	RTSI_Clock_Mode
0	RTSI_Clock_Mode

Second_Irq_A_Enable_Register

Address: 74 Type: Write-only

15	Reserved
14	Reserved
13	Reserved
12	Reserved
11	Reserved
10	Reserved
9	Pass_Thru_0_Second_Irq_Enable
8	G0_Gate_Second_Irq_Enable
7	AI_FIFO_Second_Irq_Enable
6	G0_TC_Second_Irq_Enable
5	AI_Error_Second_Irq_Enable
4	AI_STOP_Second_Irq_Enable
3	AI_START_Second_Irq_Enable
2	AI_START2_Second_Irq_Enable
1	AI_START1_Second_Irq_Enable
0	AI_SC_TC_Second_Irq_Enable

Second_Irq_B_Enable_Register

Address: 76 Type: Write-only

15	Reserved
14	Reserved
13	Reserved
12	Reserved
11	Pass_Thru_1_Second_Irq_Enable
10	G1_Gate_Second_Irq_Enable
9	G1_TC_Second_Irq_Enable
8	AO_FIFO_Second_Irq_Enable
7	AO_UI2_TC_Second_Irq_Enable
6	AO_UC_TC_Second_Irq_Enable
5	AO_Error_Second_Irq_Enable
4	AO_STOP_Second_Irq_Enable
3	AO_START_Second_Irq_Enable
2	AO_UPDATE_Second_Irq_Enable
1	AO_START1_Second_Irq_Enable
0	AO_BC_TC_Second_Irq_Enable

Window_Address_Register

Address: 0 Type: Write-only

15	Window_Address
14	Window_Address
13	Window_Address
12	Window_Address
11	Window_Address
10	Window_Address
9	Window_Address
8	Window_Address
7	Window_Address
6	Window_Address
5	Window_Address
4	Window_Address
3	Window_Address
2	Window_Address
1	Window_Address
0	Window_Address

Window_Data_Register

Address: 1 Type: Read/Write

15	Window_Data
14	Window_Data
13	Window_Data
12	Window_Data
11	Window_Data
10	Window_Data
9	Window_Data
8	Window_Data
7	Window_Data
6	Window_Data
5	Window_Data
4	Window_Data
3	Window_Data
2	Window_Data
1	Window_Data
0	Window_Data

Write_Strobe_0_Register

Address: 82 Type: Write-only

15	Reserved
14	Reserved
13	Reserved
12	Reserved
11	Reserved
10	Reserved
9	Reserved
8	Reserved
7	Reserved
6	Reserved
5	Reserved
4	Reserved
3	Reserved
2	Reserved
1	Reserved
0	Reserved

Write_Strobe_1_Register

Address: 83 Type: Write-only

15	Reserved
14	Reserved
13	Reserved
12	Reserved
11	Reserved
10	Reserved
9	Reserved
8	Reserved
7	Reserved
6	Reserved
5	Reserved
4	Reserved
3	Reserved
2	Reserved
1	Reserved
0	Write_Strobe_1

Write_Strobe_2_Register

Address: 84 Type: Write-only

15	Reserved
14	Reserved
13	Reserved
12	Reserved
11	Reserved
10	Reserved
9	Reserved
8	Reserved
7	Reserved
6	Reserved
5	Reserved
4	Reserved
3	Reserved
2	Reserved
1	Reserved
0	Write_Strobe_2

Write_Strobe_3_Register

Address: 85 Type: Write-only

15	Reserved
14	Reserved
13	Reserved
12	Reserved
11	Reserved
10	Reserved
9	Reserved
8	Reserved
7	Reserved
6	Reserved
5	Reserved
4	Reserved
3	Reserved
2	Reserved
1	Reserved
0	Write_Strobe_3



Pin List

This appendix contains lists of the DAQ-STC pins, Table C-1 in alphabetical order and Table C-2 in numerical order. For more detailed information about a specific pin, refer to the *Pin Interface* section of the chapter that discusses that pin. For a list of pins discussed in each chapter, refer to Figure 1-3, *DAQ-STC Block Diagram*.

An asterisk following a pin name indicates that the default polarity for that pin is active low.

Refer to Table C-1 for a description of the buffer types.

Table C-1. DAQ-STC Pins in Alphabetical Order

Pin Name	Pin Number	Buffer Type
A1	64	ID
A2	63	ID
A3	62	ID
A4	59	ID
A5	58	ID
A6	57	ID
A7	56	ID
AI_FIFO_SHIFTIN*	132	O9TU
AI_STOP_IN	138	IU5
AI_STOP_OUT	109	O4TU
AIFEF*	131	IU
AIFFF*	129	IU
AIFHF*	130	IU
AIFREQ	13	O4TU
ANALOG_TRIG_DRIVE	115	O4TU
ANALOG_TRIG_IN_HI	128	IU
ANALOG_TRIG_IN_LO	127	IU

Table C-1. DAQ-STC Pins in Alphabetical Order (Continued)

Pin Name	Pin Number	Buffer Type
AO_ADDR0	148	O4TU
AO_ADDR1	149	O4TU
AO_ADDR2	150	O4TU
AO_ADDR3	151	O4TU
AOFEF*	152	IU
AOFFF*	154	IU
AOFFRT*	155	O4TU
AOFHF*	153	IU
AOFREQ	14	O9TU
BC_TC	105	O4TU
CHRDY_IN	39	IU5
CHRDY_OUT	74	OD18U
CONVERT*	141	O9TU
CPUDACREQ*	17	IU
CPUDACWR*	147	O4TU
CS*	68	IU
CTRL0	31	O4TU
CTRL1	32	O4TU
CTRL2	33	O4TU
CTRL3	34	O4TU
CTRL4	35	O4TU
CTRL5	36	O4TU
CTRL6	37	O4TU
CTRL7	38	O4TU
D0	75	B9TU
D1	76	B9TU
D2	77	B9TU

Table C-1. DAQ-STC Pins in Alphabetical Order (Continued)

Pin Name	Pin Number	Buffer Type
D3	78	B9TU
D4	82	B9TU
D5	83	B9TU
D6	84	B9TU
D7	85	B9TU
D8	55	B9TU
D9	54	B9TU
D10	52	B9TU
D11	51	B9TU
D12	49	B9TU
D13	47	B9TU
D14	45	B9TU
D15	43	B9TU
DACWR*0	157	O4TU
DACWR*1	158	O4TU
DIO0/SDOUT	126	B18TU
DIO1	124	B18TU
DIO2	119	B18TU
DIO3	116	B18TU
DIO4/SDIN	114	B18TU
DIO5	112	B18TU
DIO6	110	B18TU
DIO7	107	B18TU
DIV_TC	117	O4TU
EOC	135	IU
EXTMUX_CLK	104	O9TU
EXTSTROBE*/SDCLK	103	O9TU

Table C-1. DAQ-STC Pins in Alphabetical Order (Continued)

Pin Name	Pin Number	Buffer Type
FOUT	87	O9TU
G_OUT0/RTSI_IO	88	B9TU
G_OUT1/DIV_TC_OUT	94	O9TU
G_UP_DOWN0	108	ID/IU ¹
G_UP_DOWN1	111	ID/IU ¹
GHOST	142	IU
GND	21	—
GND	41	—
GND	42	—
GND	79	—
GND	80	—
GND	101	—
GND	121	—
GND	122	—
GND	159	—
GND	160	—
INTEL/MOTO*	113	IU
IRQ_IN0	73	IU
IRQ_IN1	71	IU
IRQ_OUT0	72	OD18U
IRQ_OUT1	70	OD18U
IRQ_OUT2	67	OD18U
IRQ_OUT3	53	OD18U
IRQ_OUT4	50	OD18U
IRQ_OUT5	48	OD18U
IRQ_OUT6	46	OD18U
IRQ_OUT7	44	OD18U

Table C-1. DAQ-STC Pins in Alphabetical Order (Continued)

Pin Name	Pin Number	Buffer Type
LDAC*0	123	O4TU
LDAC*1	125	O4TU
LOCALMUX_CLK*	136	O4TU
LOCALMUX_FFRT*	133	O9TU
MUXFEF	137	IU
OSC	19	IS
OUTBRD_OSC	22	O9TU
PFI0/AI_START1	99	B9TU
PFI1/AI_START2	98	B9TU
PFI2/CONV*	97	B9TU
PFI3/G_SRC1	96	B9TU
PFI4/G_GATE1	95	B9TU
PFI5/UPDATE*	93	B9TU
PFI6/AO_START1	92	B9TU
PFI7/AI_START	91	B9TU
PFI8/G_SRC0	90	B9TU
PFI9/G_GATE0	89	B9TU
RD/WR*	65	IU
RESET*	61	IU
RTSI_BRD0	9	B9TU
RTSI_BRD1	10	B9TU
RTSI_BRD2	11	B9TU
RTSI_BRD3	12	B9TU
RTSI_OSC	18	B9TU
RTSI_TRIGGER0	2	B9TU
RTSI_TRIGGER1	3	B9TU
RTSI_TRIGGER2	4	B9TU

Table C-1. DAQ-STC Pins in Alphabetical Order (Continued)

Pin Name	Pin Number	Buffer Type
RTSI_TRIGGER3	5	B9TU
RTSI_TRIGGER4	6	B9TU
RTSI_TRIGGER5	7	B9TU
RTSI_TRIGGER6	8	B9TU
SC_TC	86	O9TU
SCAN_IN_PROG	139	O4TU
SEC_IRQ_OUT_BANK0	15	OD18U
SEC_IRQ_OUT_BANK1	16	OD18U
SHIFTIN*	143	O9TU
SI_TC	118	O4TU
SOC	134	IU
STATUS0	23	ID
STATUS1	24	ID
STATUS2	25	ID
STATUS3	26	ID
TEST_IN*	102	IU5
TEST_OUT	69	O9
TMRDACREQ	156	O9TU
TMRDACWR*	146	O4TU
UC_TC	106	O4TU
UPDATE*	144	O9TU
UPDATE2*	145	O9TU
VCC	1	—
VCC	20	—
VCC	40	—
VCC	81	—
VCC	100	—

Table C-1. DAQ-STC Pins in Alphabetical Order (Continued)

Pin Name	Pin Number	Buffer Type
VCC	120	—
VCC(ADDED)	60	—
VCC(ADDED)	140	—
WR/DS*	66	IU
WRITE_STROBE0	27	O4TU
WRITE_STROBE1	28	O4TU
WRITE_STROBE2	29	O4TU
WRITE_STROBE3	30	O4TU

¹ These pins are pulled down on the first revision of the DAQ-STC, and pulled up on the later revisions. See Appendix D, [DAQ-STC Revision History](#), for DAQ-STC revision information.

Table C-2. Summary of Buffer Types

Name	In/Out	Input Level	Output Level	Resistor (Nominal Value)	I _{OL} (mA)	I _{OH} (mA)
B18TU	In/Out	TTL	CMOS 3 State	50 k Up	24	-13
B9TU	In/Out	TTL	CMOS 3 State	50 k Up	9	-5
OD18U	Out	—	Nch Open Drain	50 k Up	24	0
O9TU	Out	—	CMOS 3 State	50 k Up	9	-5
O9	Out	—	CMOS	—	9	-5
O4TU	Out	—	CMOS 3 State	50 k Up	4.5	-2.5
ID	In	TTL	—	50 k Down	—	—
IS	In	TTL Schmitt	—	—	—	—
IU	In	TTL	—	50 k Up	—	—
IU5	In	TTL	—	5 k Up	—	—

**Note**

Pull-up/pull-down resistance values are as follows:

Nominal Value	Resistance (k Ω)		
	Minimum	Typical	Maximum
50 k Ω	17	38	100
5 k Ω	2.9	5	13

DAQ-STC Revision History

This appendix lists the differences between the first two revisions of the DAQ-STC and identifies those boards containing the first revision of the DAQ-STC.

The first revision of the DAQ-STC is packaged in a 160-pin quad flat pack (QFP). It was revised to use a smaller, lower profile 160-pin LQFP package for PCMCIA applications. At that time, three circuit modifications were made, two of which may affect user applications and one which reduced board cost.

- The analog output section now supports hardware and software gating.
- The up/down pin for each general purpose counter/time is now pulled up instead of pulled down.
- The dat bus is latched during a read from the general purpose counter/timer hardware save registers, which removes the need for an external latch.

All but the earliest shipments of the first and second revision DAQ-STCs contain a part number printed on the chip package. The first revision of the DAQ-STC contains the number 702088-01. The second revision contains the number 690286-01.

The following table lists the products that used the first revision of the DAQ-STC. It includes product name and latest PWB revision. A PWB with an earlier revision than listed, such as A instead of B, also uses the first revision of the DAQ-STC. The PWB revision is printed on the back side of each board. It is not the same as the CCA number typically printed on a label and located on the front of the board.

Product Name	PWB Number
AT-MIO-16E-1	183020B-01
AT-MIO-16E-2	182412D-01
AT-MIO-64E-10	182642B-01
AT-MIO-16DE-10	182637C-01
AT-MIO-16XE-50	182542C-01
PCI-MIO-16XE-50	183118C-01
DAQPad-MIO-16XE-50	182951A-01

Product Name	PWB Number
NEC-MIO-16E-4	182397C-01
NEC-AI-16E-4	182397C-01
NEC-MIO-16XE-50	182832A-01
NEC-AI-16XE-50	182832A-01
SB-MIO-16E-4	182467C-01
VXI-MIO-64E-1	183006C-01
VXI-MIO-64XE-10	183392B-01

Customer Communication

For your convenience, this appendix contains forms to help you gather the information necessary to help us solve your technical problems and a form you can use to comment on the product documentation. When you contact us, we need the information on the Technical Support Form and the configuration form, if your manual contains one, about your system configuration to answer your questions as quickly as possible.

National Instruments has technical assistance through electronic, fax, and telephone systems to quickly provide the information you need. Our electronic services include a bulletin board service, an FTP site, a fax-on-demand system, and e-mail support. If you have a hardware or software problem, first try the electronic support systems. If the information available on these systems does not answer your questions, we offer fax and telephone support through our technical support centers, which are staffed by applications engineers.

Electronic Services

Bulletin Board Support

National Instruments has BBS and FTP sites dedicated for 24-hour support with a collection of files and documents to answer most common customer questions. From these sites, you can also download the latest instrument drivers, updates, and example programs. For recorded instructions on how to use the bulletin board and FTP services and for BBS automated information, call 512 795 6990. You can access these services at:

United States: 512 794 5422

Up to 14,400 baud, 8 data bits, 1 stop bit, no parity

United Kingdom: 01635 551422

Up to 9,600 baud, 8 data bits, 1 stop bit, no parity

France: 01 48 65 15 59

Up to 9,600 baud, 8 data bits, 1 stop bit, no parity

FTP Support

To access our FTP site, log on to our Internet host, `ftp.natinst.com`, as `anonymous` and use your Internet address, such as `joesmith@anywhere.com`, as your password. The support files and documents are located in the `/support` directories.

Fax-on-Demand Support

Fax-on-Demand is a 24-hour information retrieval system containing a library of documents on a wide range of technical information. You can access Fax-on-Demand from a touch-tone telephone at 512 418 1111.

E-Mail Support (Currently USA Only)

You can submit technical support questions to the applications engineering team through e-mail at the Internet address listed below. Remember to include your name, address, and phone number so we can contact you with solutions and suggestions.

support@natinst.com

Telephone and Fax Support

National Instruments has branch offices all over the world. Use the list below to find the technical support number for your country. If there is no National Instruments office in your country, contact the source from which you purchased your software to obtain support.

Country	Telephone	Fax
Australia	03 9879 5166	03 9879 6277
Austria	0662 45 79 90 0	0662 45 79 90 19
Belgium	02 757 00 20	02 757 03 11
Brazil	011 288 3336	011 288 8528
Canada (Ontario)	905 785 0085	905 785 0086
Canada (Québec)	514 694 8521	514 694 4399
Denmark	45 76 26 00	45 76 26 02
Finland	09 725 725 11	09 725 725 55
France	01 48 14 24 24	01 48 14 24 14
Germany	089 741 31 30	089 714 60 35
Hong Kong	2645 3186	2686 8505
Israel	03 6120092	03 6120095
Italy	02 413091	02 41309215
Japan	03 5472 2970	03 5472 2977
Korea	02 596 7456	02 596 7455
Mexico	5 520 2635	5 520 3282
Netherlands	0348 433466	0348 430673
Norway	32 84 84 00	32 84 86 00
Singapore	2265886	2265887
Spain	91 640 0085	91 640 0533
Sweden	08 730 49 70	08 730 43 70
Switzerland	056 200 51 51	056 200 51 55
Taiwan	02 377 1200	02 737 4644
United Kingdom	01635 523545	01635 523154
United States	512 795 8248	512 794 5678

Technical Support Form

Photocopy this form and update it each time you make changes to your software or hardware, and use the completed copy of this form as a reference for your current configuration. Completing this form accurately before contacting National Instruments for technical support helps our applications engineers answer your questions more efficiently.

If you are using any National Instruments hardware or software products related to this problem, include the configuration forms from their user manuals. Include additional pages if necessary.

Name _____

Company _____

Address _____

Fax (____) _____ Phone (____) _____

Computer brand _____ Model _____ Processor _____

Operating system (include version number) _____

Clock speed _____ MHz RAM _____ MB Display adapter _____

Mouse ___ yes ___ no Other adapters installed _____

Hard disk capacity _____ MB Brand _____

Instruments used _____

National Instruments hardware product model _____ Revision _____

Configuration _____

National Instruments software product _____ Version _____

Configuration _____

The problem is: _____

List any error messages: _____

The following steps reproduce the problem: _____

DAQ-STC Hardware and Software Configuration Form

Record the settings and revisions of your hardware and software on the line to the right of each item. Complete a new copy of this form each time you revise your software or hardware configuration, and use this form as a reference for your current configuration. Completing this form accurately before contacting National Instruments for technical support helps our applications engineers answer your questions more efficiently.

National Instruments Products

DAQ hardware revision _____

Interrupt level of hardware _____

DMA channels of hardware _____

Base I/O address of hardware _____

Programming choice _____

HiQ, NI-DAQ, LabVIEW, or LabWindows version _____

Other boards in system _____

Base I/O address of other boards _____

DMA channels of other boards _____

Interrupt level of other boards _____

Other Products

Computer make and model _____

Microprocessor _____

Clock frequency or speed _____

Type of video board installed _____

Operating system version _____

Operating system mode _____

Programming language _____

Programming language version _____

Other boards in system _____

Base I/O address of other boards _____

DMA channels of other boards _____

Interrupt level of other boards _____

Documentation Comment Form

National Instruments encourages you to comment on the documentation supplied with our products. This information helps us provide quality products to meet your needs.

Title: *DAQ-STC™ Technical Reference Manual*

Edition Date: *January 1999*

Part Number: *340934B-01*

Please comment on the completeness, clarity, and organization of the manual.

If you find errors in the manual, please record the page numbers and describe the errors.

Thank you for your help.

Name _____

Title _____

Company _____

Address _____

E-Mail Address _____

Phone (____) _____ Fax (____) _____

Mail to: Technical Publications
National Instruments Corporation
6504 Bridge Point Parkway
Austin, Texas 78730-5039

Fax to: Technical Publications
National Instruments Corporation
512 794 5678

Glossary

Prefix	Meaning	Value
p-	pico	10^{-12}
n-	nano-	10^{-9}
μ -	micro-	10^{-6}
m-	milli-	10^{-3}
k-	kilo-	10^3
M-	mega-	10^6
G-	giga-	10^9

Symbol

Σ indicates the end of a sequence

Ω ohms

A

A<1..7> address signal, channels 1 through 7

A/D analog-to-digital

ADC A/D converter

ADFEF AI data FIFO empty flag

ADFFF AI data FIFO full flag

ADFHF AI data FIFO empty flag

ADFREQ AI data FIFO half-full flag

ADR_START1 internal START1 signal without Master/Slave synchronization

ADR_START2 START2 signal without master/slave synchronization

Glossary

AD_START	output version of START signal
AD_START1	output version of START1 signal
AD_VSTART2	output version of START2 signal
AI	analog input
AIERROR	AI error signal
AIFEF	AI data FIFO empty flag
AIFFF	AI data FIFO full flag
AIFHF	AI data FIFO half-full flag
AIFIFOREQ	AI FIFO request signal
AIFREQ	AI data FIFO request
AITM	analog input timing/control module
AI_FIFO_SHIFTIN	data FIFO write clock signal
AI_IN_TIMEBASE1	internal timebase signal for the analog input module
AI_OUT_TIMEBASE	AI output timebase signal
AI_ST1	internal analog input signal START1
AI_ST2	internal analog input signal START1
AI_STOP_IN	dedicated stop input signal
AI_STOP_OUT	dedicated stop output signal
AI_TB1	internal analog input signal AI_IN_TIMEBASE1
ANALOG_TRIG_DRIVE	analog trigger drive signal
ANALOG_TRIG_IN_HI	analog trigger input high voltage reference
ANALOG_TRIG_IN_LO	analog input trigger low voltage reference
AO	analog output
AO START1	AO start signal

AO UPDATE	AO update signal
AOFEF	AO FIFO empty flag
AOFFF	AO FIFO full flag
AOFFRT	data FIFO retransmit
AOFHF	AO FIFO half-full flag
AOFREQ	data FIFO request signal
AOTM	analog output timing/control module
AO_ADDR<0..3>	AO address signal, channels 0 through 3
AO_END1	end on UC_TC signal
AO_END2	end on BC_TC signal
AO_IN_TIMEBASE1	internal timebase for analog output module
AO_OUT_TIMEBASE	AO output clock signal
AO_TB1	AO timebase 1 signal
ASIC	application-specific integrated circuit

B

BC	24-bit buffer repetition counter
BC_CE	BC count enable signal
BC_CLK	BC clock signal
BCD	binary coded decimal
BC_DISARM	BC disarm signal
BC_HOLD	BC hold signal
BC_LOAD	BC load signal
BC_LOAD_SRC	BC load source signal

BC_TC	buffer repetition counter TC signal
BC_SRC	BC source signal

C

CHADDR	4-bit channel address counter
CHRDY_IN	board-level channel ready signal
CHRDY_OUT	channel ready output signal
CONVERT*	ADC conversion strobe signal
CPU	central processing unit
CPUDACREQ	CPU request for access to the DAC
CPUDACWR	CPU write to the DAC
CS	chip select signal
CTR_GATE	general purpose counter gate signal
CTRL<0..7>	control signal, channels 0 through 7
CTROUT	counter output signal
CTRSRC	general purpose counter source signal

D

D<0..15>	bidirectional tri-state data bus signals
D/A	digital-to-analog
DAC	D/A converter
DACUPDN	DAC update signal
DACWR<0..1>	DAC write strobe 0 through 1
DAQ	data acquisition

DAQ-STC	data acquisition timing controller
DA_ST1ED	output version of START1
DA_START1	start 1 signal without master/slave sync
DC	direct current
DIO	digital I/O
DIO<0..7>	digital lines 0 through 7
DIO0/SDOUT	digital I/O 0 serial data output signal
DIO4/SDIN	digital I/O 4 serial data input signal
DIV	16-bit divide-down counter
DIV_CE	DIV clock enable signal
DIV_CLK	DIV clock signal
DIV_LOAD	DIV load signal
DIV_TC	DIV counter TC signal
DMA	direct memory access

E

EOC	end of conversion signal
ETS	equivalent time sampling
EXTMUX_CLK	external multiplexer clock signal
EXTSTROBE	external strobe signal
EXTSTROBE/SDCLK	external strobe serial data clock signal
EXT_CLK	external clock signal
EXT_DIVTC	external DIV_TC signal
EXT_GATE	external gate signal

EXT_GATE2 secondary external gate signal

F

F Farad

FIFO first-in-first-out

FOUT frequency output signal

FSCLK fast sample clock/fast update clock signal

FSC_SRC fast edge of SC source

FSK frequency shift keying

G

G0_TC G_TC signal from general purpose counter 0

GHOST ghost input signal

GND ground

GOUT0 G_OUT signal from general-purpose counter 0

GOUT1 G_OUT signal from general-purpose counter 1

GPCT general purpose counter/timer module

G_CONTROL GPCT counter control signal

G_GATE GPCT gate input signal

G_IN_TIMEBASE1 internal timebase for GPCT module

G_OUT GPCT output signal

G_TB1 internal signal G_IN_TIMEBASE1

G_TC GPCT counter TC signal

G_UP_DOWN GPCT up/down control input signal

G_UP_DOWN0	dedicated up/down control for the GPCTs
G_UP_DOWN1	dedicated up/down control for the GPCTs

H

HW	hardware
Hz	Hertz

I

ICM	interrupt control module
ID	TTL input pin, pull down (50 k Ω)
II	input clamp voltage
IL	input leakage current
INTEL/MOTO	Intel/Motorola bus interface selection signal
INTERRUPT	interrupt signal
INTERRUPT.G_OUT	GPCT counter T related signal
INT_SCLK_SEL	internal update indicator signal
IN_TIMEBASE2	slow internal timebase signal
I/O	input/output
I_{oh}	high-level output current
I_{ol}	low-level output current
IRQ_IN<0..1>	individually programmable polarity general-purpose interrupt input signal
IRQ_OUT<0..7>	programmable polarity interrupt output signal
ISA	Industry Standard Architecture
ISR	interrupt service program

L

LDAC<0..1>	DAC load 0 through 1
LOCALMUX_CLK*	configuration FIFO advance clock signal
LOCALMUX_FFRT*	configuration FIFO retransmit signal
LSB	least significant bit

M

MAX	maximum
MB	megabytes of memory
MHz	megahertz
MIN	minimum
MIO	multifunction input/output
MISB	Multiple Iterations of a Single Buffer
MSB	most significant bit
Mux	multiplexer
MUXFEF	configuration FIFO empty flag signal

O

OSC	oscillator source signal
OUTBRD_OSC	oscillator source signal for output to the board
OUT_CLK	AI_OUT_TIMEBASE signal

P

PFI	programmable function input
-----	-----------------------------

PFI<0..9>	programmable function input signals 0 through 9
PFI0/AI_START1	PFI0/START1 trigger from analog input
PFI1/AI_START2	PFI1/START2 trigger from analog input
PFI2/CONV	PFI2/ADC conversion strobe from analog input
PFI3/G_SRC1	PFI3/general-purpose counter 1 source
PFI4/G_GATE1	PFI4/general-purpose counter 1 gate
PFI5/UPDATE	PFI5/primary update from analog output
PFI6/AO_START1	PFI6/START1 trigger from analog output
PFI7/AI_START	PFI7/START trigger from analog input
PFI8/G_SRC0	PFI8/general-purpose counter 0 source
PFI9/G_GATE0	PFI9/general-purpose counter 0 gate
POLARITY	active or true state of a signal, i.e. active- high or active-low

R

RD/WR	in Intel mode, a read bus signal in Motorola mode a read/write input signal
RESET	active low signal that resets the DAQ-STC during initialization
RGOUT0	a RTSI source selection from the I/O pins
RMA	Return Manual Authorization
RTM	RTSI trigger module
RTSI	Real-Time System Integration
RTSI_BRD<0..3>	RTSI board interface signal, channels 0 through 3
RTSI_OSC	RTSI oscillator source signal
RTSI_TRIGGER<0..6>	RTSI trigger signal, channels 0 through 6

S

s	seconds
S	samples
SC	scan counter
SCAN_IN_PROG	scan in progress signal
SCKG	internal sample clock signal
SCLK	internal update signal
SCLKG	internal sample clock signal
SC_CE	SC count enable signal
SC_CLK	SC clock signal
SC_GATE	SC counter gate signal
SC_HOLD	SC hold signal
SC_LOAD	SC load signal
SC_LOAD_SRC	SC load source signal
SC_SRC	SC source signal
SC_START1	START1 signal synchronized to SC_RC
SC_TC	SC counter TC signal
SCXI	Signal Conditioning eXtensions for Instrumentation
SEC_IRQ_OUT_BANK0	secondary interrupt output for interrupt group A
SEC_IRQ_OUT_BANK1	secondary interrupt output for interrupt group B
SEL<0..4>	select signal, channels 0 through 4
SHIFTIN	data shift pulse signal
SI	24-bit scan interval counter

SI2	16-bit scan interval counter
SI2_CE	SI2 count enable signal
SI2_CLK	SI2 clock signal
SI2_LOAD	SI2 load signal
SI2_LOAD_SRC	SI2 load source signal
SI2_SRC	SI2 source signal
SI2_TC	SI2 counter TC signal
SI_CE	SI count enable signal
SI_CLK	SI clock signal
SI_DISARM	SI disarm signal
SI_HOLD	SI hold signal
SI_LOAD	SI load signal
SI_LOAD_SRC	SI load source signal
SI_SRC	SI source signal
SI_START1	START1 synchronized to SI_SRC signal
SI_TC	SI counter TC signal
SOC	start of conversion signal
START	start scan signal
START1	start trigger signal
START2	stop trigger used by the SC counter in the pretrigger mode
STATUS<0..3>	status signal, channels 0 through 3
STOP	stop scan signal that terminates the buffer in progress
STST_GATE	start/stop gate signal
SW	software

T

TC	terminal count
T _A	ambient temperature
TC	terminal count signal
TEST_IN*	test input signal
TEST_OUT	test output signal
TTL	transistor-transistor logic
typ	typical

U

UC	24-bit update counter
UC	update counter
UC_CE	UC count enable signal
UC_CLK	UC clock signal
UC_HOLD	UC hold signal
UC_LOAD	UC load signal
UC_LOAD_SRC	UC load source signal
UC_TC	UC terminal count signal
UI	update interval signal
UI2	secondary update interval counter
UI2_CE	UI2 count enable signal t
UI2_CLK	UI2 clock signal and the UI2 control logic
UI2_LOAD	UI2 load signal
UI2_LOAD_SRC	UI2 load source signal

UI2_SRC	UI2 source
UI2_TC	secondary update interval terminal count signal
UI_CE	UI count enable signal
UI_CLK	UI clock signal
UI_DISARM	UI disarm signal
UI_LOAD	UI load signal
UI_LOAD_SRC	UI load source signal
UI_SRC	UI source
UI_TC	UI counter terminal count signal
UPDATE	update clock signal
UPDATE2	secondary update signal

V

V	volt
V_{dd}	power supply voltage
V_i	voltage in
V_o	voltage out

W

WR/DS	in Intel mode, a write cycle signal in Motorola mode, a read cycle signal
WRITE_STROBE<0..3>	general-purpose write strobe signal, channels 0 through 3

Index

A

A<1..7> signal (table), 9-2

absolute maximum ratings specifications, A-2

acquisition-level timing and control functions, 2-14 to 2-16

 continuous acquisition mode, 2-15

 master/slave trigger, 2-16

 posttrigger acquisition mode, 2-14

 pretrigger acquisition mode, 2-14 to 2-15

 staged acquisition, 2-16

AD_START signal (table), 2-113

AD_START1 signal (table), 2-113

AD_VSTART2 signal (table), 2-113

ADC control, 2-7

ADR_START1 signal (table), 2-113

ADR_START2 signal (table), 2-113

AI_AIFREQ_Polarity bit, 2-48

AI_Analog_Trigger_Reset bit, 2-48

AI_Arming function, 2-41

AI_Board_Environmentalize function, 2-29

AI_Board_Personalize function, 2-27

AI_Config_Memory_Empty_St bit, 2-49

AI_Configuration_End bit, 2-49

AI_Configuration_Start bit, 2-49

AI_Continuous bit, 2-49

AI_CONVERT_Original_Pulse bit, 2-50

AI_CONVERT_Output_Select bit, 2-50

AI_CONVERT_Pulse bit, 2-50

AI_CONVERT_Pulse_Timebase bit, 2-50

AI_CONVERT_Pulse_Width bit, 2-51

AI_CONVERT_Signal function, 2-38 to 2-40

AI_CONVERT_Source_Polarity bit, 2-51

AI_CONVERT_Source_Select bit, 2-51

AI_Delay_START bit, 2-52

AI_Delayed_START bit, 2-51

AI_Delayed_START2 bit, 2-52

AI_Disarm bit, 2-52

AI_DIV_Arm bit, 2-52

AI_DIV_Armed_St bit, 2-53

AI_DIV_Load_A bit, 2-53

AI_DIV_Load bit, 2-53

AI_DIV_Q_St bit, 2-53

AI_DIV_Save_Value bit, 2-53

AI_End_On_End_Of_Scan bit, 2-53

AI_End_On_SC_TC bit, 2-54

AI_EOC_Polarity bit, 2-54

AI_EOC_St bit, 2-54

AI_Error_Interrupt_Ack bit, 2-54

AI_Error_Interrupt_Enable bit, 2-54

AI_Error_Second_Irq_Enable bit, 2-54

AI_External_Gate_Mode bit, 2-55

AI_External_Gate_Polarity bit

 description, 2-55

 software gate operation, 2-31

AI_External_Gate_Select bit

 description, 2-55

 software gate operation, 2-31

AI_External_Gate_St bit, 2-55

AI_External_MUX_Present bit, 2-56

AI_EXTMUX_CLK_Output_Select bit, 2-56

AI_EXTMUX_CLK_Pulse bit, 2-56

AI_EXTMUX_CLK_Pulse_Width bit, 2-56

AI_FIFO_Empty_St bit, 2-57

AI_FIFO_Flags_Polarity bit, 2-57

AI_FIFO_Full_St bit, 2-57

AI_FIFO_Half_Full_St bit, 2-57

AI_FIFO_Interrupt_Enable bit, 2-58

AI_FIFO_Mode bit, 2-58

AI_FIFO_Request_St bit, 2-58

AI_FIFO_Second_Irq_Enable bit, 2-59

AI_FIFO_SHIFTIN signal

 description (table), 2-19

 simplified analog input model, 2-5 to 2-6

AI_Hardware_Gating function, 2-30 to 2-31

- AI_IN_TIMEBASE1 signal (table), 2-113
- AI_Initialize_Configuration_Memory_Output function, 2-28 to 2-29
- AI_Interrupt_Enable function, 2-40 to 2-41
- AI_Last_Shiftin_St bit, 2-59
- AI_LOCALMUX_CLK_Output_Select bit, 2-59
- AI_LOCALMUX_CLK_Pulse bit, 2-59
- AI_LOCALMUX_CLK_Pulse_Width bit, 2-59 to 2-60
- AI_Number_Of_Scans function, 2-33 to 2-34
- AI_OUT_TIMEBASE signal (table), 2-114
- AI_Output_Divide_By_2 bit, 2-60
- AI_Overflow_St bit, 2-60
- AI_Overrun_Mode bit, 2-60
- AI_Overrun_St bit, 2-60
- AI_Pre_Trigger bit, 2-61
- AI_Reset_All function, 2-26 to 2-27
- AI_Reset bit, 2-61
- AI_SC_Arm bit, 2-62
- AI_SC_Armed_St bit, 2-62
- AI_SC_Gate_Enable bit, 2-62
- AI_SC_Gate_St bit, 2-62
- AI_SC_Initial_Load_Source bit, 2-63
- AI_SC_Load_A bit, 2-63
- AI_SC_Load_B bit, 2-63
- AI_SC_Load bit, 2-63
- AI_SC_Next_Load_Source_St bit, 2-63
- AI_SC_Q_St bit, 2-64
- AI_SC_Reload_Mode bit, 2-64
- AI_SC_Save_St bit, 2-64
- AI_SC_Save_Trace bit, 2-64
- AI_SC_Save_Value bit, 2-64
- AI_SC_Switch_Load_On_TC bit, 2-65
- AI_SC_TC_Error_Confirm bit, 2-65
- AI_SC_TC_Error_St bit, 2-65
- AI_SC_TC_Interrupt_Ack bit, 2-65
- AI_SC_TC_Interrupt_Enable bit, 2-65
- AI_SC_TC_Output_Select bit, 2-66
- AI_SC_TC_Pulse bit, 2-66
- AI_SC_TC_Second_Irq_Enable bit, 2-66
- AI_SC_TC_St bit, 2-66
- AI_SC_Write_Switch bit, 2-66
- AI_Scan_End function, 2-37 to 2-38
- AI_SCAN_IN_PROG_Output_Select bit, 2-61
- AI_SCAN_IN_PROG_Pulse bit, 2-62
- AI_Scan_In_Progress_St bit, 2-61
- AI_Scan_Start function
 - analog input programming, 2-34 to 2-37
 - single scan programming, 2-42 to 2-43
- AI_SHIFTIN_Polarity bit, 2-67
- AI_SHIFTIN_Pulse_Width bit, 2-67
- AI_SI_Armed_St bit, 2-67
- AI_SI_Count_Enabled_St bit, 2-67
- AI_SI_Initial_Load_Source bit, 2-68
- AI_SI_Load_A bit, 2-68
- AI_SI_Load_B bit, 2-68
- AI_SI_Load bit, 2-68
- AI_SI_Next_Load_Source_St bit, 2-68
- AI_SI_Q_St bit, 2-69
- AI_SI_Reload_Mode bit, 2-69
- AI_SI_Save_Value bit, 2-69
- AI_SI_Source_Polarity bit, 2-69
- AI_SI_Source_Select bit, 2-70
- AI_SI_Special_Trigger_Delay bit, 2-70
- AI_SI_Switch_Load_On_SC_TC bit, 2-70
- AI_SI_Switch_Load_On_Stop bit, 2-70
- AI_SI_Switch_Load_On_TC bit, 2-70
- AI_SI_Write_Switch bit, 2-71
- AI_SI2_Arm bit, 2-71
- AI_SI2_Armed_St bit, 2-71
- AI_SI2_Initial_Load_Source bit, 2-71
- AI_SI2_Load_A bit, 2-71
- AI_SI2_Load_B bit, 2-72
- AI_SI2_Load bit, 2-71
- AI_SI2_Next_Load_Source_St bit, 2-72
- AI_SI2_Q_St bit, 2-72
- AI_SI2_Reload_Mode bit, 2-72
- AI_SI2_Save_Value bit, 2-72
- AI_SI2_Source_Select bit, 2-73
- AI_SOC_Polarity bit, 2-73

- AI_SOC_St bit, 2-73
- AI_Software_Gate bit, 2-73
- AI_Source_Divide_By_2 bit, 2-73
- AI_Staged_ISR function, 2-44 to 2-45
- AI_START_Edge bit, 2-74
- AI_START_Interrupt_Ack bit, 2-74
- AI_START_Interrupt_Enabled bit, 2-74
- AI_START_Output_Select bit, 2-74
- AI_START_Polarity bit, 2-74
- AI_START_Pulse bit, 2-75
- AI_START_Second_Irq_Enabled bit, 2-75
- AI_START_Select bit, 2-75
- AI_START_St bit, 2-75
- AI_Start_Stop bit, 2-76
- AI_Start_Stop_Gate_Enabled bit, 2-76
- AI_Start_Stop_Gate_St bit, 2-76
- AI_START_Sync bit, 2-76
- AI_Start_The_Acquisition function, 2-41 to 2-42
- AI_START1_Disable bit, 2-76
- AI_START1_Edge bit, 2-77
- AI_START1_Interrupt_Ack bit, 2-77
- AI_START1_Interrupt_Enabled bit, 2-77
- AI_START1_Polarity bit, 2-77
- AI_START1_Pulse bit, 2-77
- AI_START1_Second_Irq_Enabled bit, 2-78
- AI_START1_Select bit, 2-78
- AI_START1_St bit, 2-78
- AI_START1_Sync bit, 2-78
- AI_START2_Edge bit, 2-79
- AI_START2_Interrupt_Ack bit, 2-79
- AI_START2_Interrupt_Enabled bit, 2-79
- AI_START2_Interrupt_Polarity bit, 2-79
- AI_START2_Interrupt_Pulse bit, 2-79
- AI_START2_Second_Irq_Enabled bit, 2-80
- AI_START2_Select bit, 2-80
- AI_START2_St bit, 2-80
- AI_START2_Sync bit, 2-80
- AI_STOP_Edge bit, 2-81
- AI_STOP_IN signal (table), 2-20
- AI_STOP_Interrupt_Ack bit, 2-81
- AI_STOP_Interrupt_Enabled bit, 2-81
- AI_STOP_OUT signal (table), 2-20
- AI_STOP_Polarity bit, 2-81
- AI_STOP_Pulse bit, 2-81
- AI_STOP_Second_Irq_Enabled bit, 2-82
- AI_STOP_Select bit, 2-82
- AI_STOP_St bit, 2-82
- AI_STOP_Sync bit, 2-83
- AI_Trigger_Length bit, 2-83
- AI_Trigger_Once bit, 2-83
- AI_Trigger_Signals function, 2-32 to 2-33
- AIERROR signal (table), 2-113
- AIFEF* signal
 - data FIFO control, 2-7
 - data FIFO timing, 2-88
 - description (table), 2-19
- AIFFF* signal
 - data FIFO control, 2-7
 - data FIFO timing, 2-88
 - description (table), 2-19
- AIFHF* signal
 - data FIFO control, 2-7
 - data FIFO timing, 2-88
 - description (table), 2-19
- AIFIFOREQ signal (table), 2-113
- AIFREQ signal
 - data FIFO timing, 2-88
 - description (table), 2-20
 - simplified analog input model, 2-5 to 2-6
- AITM. *See* analog input timing/control module.
- analog input application, 1-2 to 1-3
- analog input functions, 2-1 to 2-18
 - acquisition-level timing and control, 2-14 to 2-16
 - continuous acquisition mode, 2-15
 - master/slave trigger, 2-16
 - posttrigger acquisition mode, 2-14
 - pretrigger acquisition mode, 2-14 to 2-15
 - staged acquisition, 2-16

- gating, 2-16 to 2-18
 - free-run gating mode, 2-17
 - halt-gating mode, 2-17 to 2-18
- low-level timing and control, 2-6 to 2-11
 - ADC control, 2-7
 - configuration FIFO and external multiplexer control, 2-7 to 2-9
 - CONVERT timing, 2-9 to 2-11
 - Data FIFO control, 2-7
- scan-level timing and control, 2-11 to 2-13
 - external START mode, 2-12 to 2-13
 - internal START mode, 2-11 to 2-12
- single-wire mode, 2-18
- analog input timing/control module, 2-1 to 2-133
 - block diagram, 2-112
 - counter outputs, 2-105 to 2-106
 - DIV_TC, 2-106
 - SC_TC, 2-105
 - SI_TC, 2-105
 - counters, 2-123 to 2-130
 - DIV control, 2-129 to 2-130
 - DIV counter, 2-128
 - SC control, 2-123 to 2-125
 - SC counter, 2-123
 - SI control, 2-126 to 2-127
 - SI counter, 2-126
 - SI2 control, 2-127 to 2-128
 - SI2 counter, 2-127
 - error detection, 2-132
 - overflow error, 2-132
 - overrun error, 2-132
 - SC_TC error, 2-132
 - external gating, 2-109 to 2-111
 - features, 2-2 to 2-3
 - internal signals and operation (table), 2-113 to 2-119
 - interrupt control, 2-130 to 2-131
 - macro-level analog input timing, 2-106 to 2-108
 - nominal signal pulsewidths, 2-133
 - overflow error, 2-132
 - overview, 2-1
 - pin locator interface (table), 2-19 to 2-23
 - programming information, 2-24 to 2-83
 - arming, 2-41
 - bitfield descriptions, 2-48 to 2-83
 - board environment setup, 2-29 to 2-30
 - board power-up initialization, 2-27 to 2-28
 - changing scan rate during acquisition, 2-43 to 2-44
 - convert signal, 2-38 to 2-40
 - enable interrupts, 2-40 to 2-41
 - end of scan, 2-37 to 2-38
 - FIFO request, 2-30
 - hardware gate programming, 2-30 to 2-31
 - initialize configuration memory output, 2-28 to 2-29
 - interrupts, 2-46 to 2-48
 - master/slave operation considerations, 2-45 to 2-46
 - number of scans, 2-33
 - overview, 2-25 to 2-26
 - register and bitfield considerations, 2-24
 - resetting, 2-26 to 2-27
 - sequence of functions for, 2-42
 - single scan, 2-42 to 2-43
 - software gate operation, 2-31
 - staged acquisition, 2-44 to 2-45
 - start of scan, 2-34 to 2-37
 - starting the acquisition, 2-41 to 2-42
 - trigger signals, 2-32 to 2-33
 - windowing registers, 2-25
 - simplified model, 2-4 to 2-6
 - specifications, A-1

- timing diagrams, 2-84 to 2-111
 - basic analog input timing, 2-86 to 2-87
 - configuration memory, 2-89 to 2-91
 - CONVERT_SRC signal, 2-84 to 2-85
 - data FIFOs, 2-88
 - external CONVERT source, 2-92 to 2-93
 - external triggers, 2-93 to 2-97
 - maximum rate analog input, 2-91 to 2-92
 - OUT_CLK signal, 2-85
 - SCAN_IN_PROG deassertion, 2-103
 - signal definitions, 2-84 to 2-85
 - START trigger and SCAN_IN_PROG assertion, 2-100 to 2-103
 - START1 and START2 triggers, 2-97 to 2-100
 - STOP trigger, 2-103 to 2-104
 - trigger output, 2-97 to 2-104
- trigger selection and conditioning, 2-119 to 2-122
 - edge detection, 2-122
 - EXT_GATE routing logic (figure), 2-121
 - PFI selectors (table), 2-121
 - START and STOP routing logic (figure), 2-120
 - START1 and START2 routing logic (figure), 2-120
 - synchronization, 2-122
 - trigger signals, 2-122 to 2-123
- analog output application, 1-3 to 1-4
- analog output functions, 3-5 to 3-16
 - buffer timing and control for primary analog output, 3-12 to 3-16
 - continuous mode, 3-13 to 3-14
 - master/slave trigger, 3-15 to 3-16
 - mute buffers, 3-15
 - single-buffer mode, 3-13
 - waveform staging, 3-14 to 3-15
- DAC interface, 3-8
- data interfaces, 3-8 to 3-11
 - FIFO data interface, 3-8 to 3-10
 - serial link data interface, 3-10
 - unbuffered data interface, 3-11
- primary group analog output modes, 3-5 to 3-7
 - CPU-driven analog output, 3-6 to 3-7
 - DAQ-STC and CPU conflict, 3-7
 - DAQ-STC-driven analog output, 3-6
- secondary analog output, 3-16
- update timing for primary group, 3-11 to 3-12
 - external UPDATE, 3-12
 - internal UPDATE, 3-11 to 3-12
- analog output programming, 3-20 to 3-84
- bitfield descriptions, 3-45 to 3-84
- primary analog output operation, 3-20 to 3-32
 - arming, 3-30 to 3-31
 - board power-up initialization, 3-22 to 3-23
 - changing update rate, 3-34 to 3-35
 - channel select, 3-28
 - enable interrupts, 3-30
 - FIFO mode, 3-29 to 3-30
 - interrupts, 3-35 to 3-37
 - LDAC source and UPDATE mode, 3-29
 - master/slave operation considerations, 3-35
 - number of buffers, 3-24 to 3-26
 - overview, 3-21
 - resetting, 3-21 to 3-22
 - sequence of functions, 3-31 to 3-32
 - starting the waveform, 3-30 to 3-31
 - stop on error, 3-29
 - trigger signals, 3-23 to 3-24
 - update selection, 3-26 to 3-28

- secondary analog output operation, 3-38 to 3-42
 - arming, 3-41
 - board power-up initialization, 3-39
 - changing update rate, 3-44 to 3-45
 - counting for waveform staging, 3-40
 - hardware gate programming, 3-39
 - interrupts, 3-45
 - master/slave operation
 - considerations, 3-45
 - overview, 3-38
 - resetting, 3-38
 - software gate operation, 3-40
 - update selection, 3-40 to 3-41
 - waveform staging, 3-42 to 3-44
- analog output timing/control module, 3-1 to 3-124
 - block diagram, 3-109
 - counters, 3-117 to 3-121
 - BC control, 3-120 to 3-121
 - BC counter, 3-120
 - UC control, 3-119
 - UC counter, 3-118 to 3-119
 - UI control, 3-118
 - UI counter, 3-117
 - UI2 control, 3-121
 - UI2 counter, 3-121
 - error detection, 3-122 to 3-123
 - BC_TC error, 3-123
 - BC_TC trigger error, 3-123
 - overrun error, 3-122
 - UI2_TC error, 3-123
 - features, 3-2 to 3-3
 - functions. *See* analog output functions.
 - internal signals and operation (table), 3-109 to 3-114
 - interrupt control, 3-122
 - nominal signal pulsewidths, 3-124
 - output control, 3-123 to 3-124
 - overview, 3-1 to 3-2
 - pin interface (table), 3-16 to 3-20
 - programming. *See* analog output programming.
 - simplified model, 3-4 to 3-5
 - specifications, A-1
 - timing diagrams, 3-84 to 3-108
 - counter outputs, 3-107 to 3-108
 - CPU-driven analog output
 - timing, 3-88
 - DAQ-STC- and CPU-driven analog output timing, 3-90 to 3-92
 - DAQ-STC-driven analog output timing, 3-86 to 3-88
 - decoded signal timing, 3-94 to 3-95
 - external trigger timing, 3-102 to 3-104
 - local buffer mode timing, 3-96 to 3-97
 - maximum update rate timing, 3-101 to 3-102
 - secondary analog output timing, 3-93
 - signal definitions, 3-84 to 3-86
 - trigger output, 3-104 to 3-107
 - unbuffered data interface timing, 3-98 to 3-100
 - trigger selection and conditioning, 3-114 to 3-116
 - edge detection, 3-116
 - EXT_GATE and EXT_GATE2 routing logic (figure), 3-115
 - PFI selectors (table), 3-115 to 3-116
 - START1 routing logic (figure), 3-115
 - synchronization, 3-116
 - trigger signals, 3-116
 - ANALOG_TRIG_DRIVE signal (table), 10-9
 - ANALOG_TRIG_IN_HI signal (table), 10-9
 - ANALOG_TRIG_IN_LO signal (table), 10-9
 - analog trigger circuit, 10-3 to 10-6
 - high-hysteresis mode (figure), 10-5
 - high-window mode (figure), 10-4
 - low-hysteresis mode (figure), 10-6
 - low-window mode (figure), 10-4

- middle-window mode (figure), 10-5
- programming, 10-12
- Analog_Trigger_Drive bit, 10-12
- Analog_Trigger_Enable bit, 10-13
- Analog_Trigger_Mode bit, 10-13
- AO_ADDR<0..3> signal
 - CPU-driven analog output, 3-6 to 3-7
 - CPU-driven analog output timing, 3-88 to 3-89
 - DAQ-STC-driven analog output, 3-6, 3-86 to 3-88
 - description (table), 3-16
 - local buffer mode timing, 3-97 to 3-97
 - simplified analog output model, 3-4
 - unbuffered data interface, 3-11
 - unbuffered data interface timing, 3-98 to 3-100
- AO_Analog_Trigger_Reset bit, 3-45
- AO_AOFREQ_Enable bit, 3-46
- AO_AOFREQ_Polarity bit, 3-46
- AO_Arming function, 3-30 to 3-31
- AO_BC_Arm bit, 3-46
- AO_BC_Armed_St bit, 3-46
- AO_BC_Gate_Enable bit, 3-46
- AO_BC_Gate_St bit, 3-47
- AO_BC_Initial_Load_Source bit, 3-47
- AO_BC_Load_A bit, 3-47
- AO_BC_Load_B bit, 3-47
- AO_BC_Load bit, 3-47
- AO_BC_Next_Load_Source bit, 3-48
- AO_BC_Q_St bit, 3-48
- AO_BC_Reload_Mode bit, 3-48
- AO_BC_Save_St bit, 3-48
- AO_BC_Save_Trace bit, 3-48
- AO_BC_Save_Value bit, 3-49
- AO_BC_Source_Select bit, 3-49
- AO_BC_Switch_Load_On_TC bit, 3-49
- AO_BC_TC_Error_Confirm bit, 3-49
- AO_BC_TC_Error_St bit, 3-49
- AO_BC_TC_Interrupt_Ack bit, 3-50
- AO_BC_TC_Interrupt_Enable bit, 3-50
- AO_BC_TC_Second_Irq_Enable bit, 3-50
- AO_BC_TC_St bit, 3-50
- AO_BC_TC_Trigger_Error_Confirm bit, 3-50
- AO_BC_TC_Trigger_Error_St bit, 3-51
- AO_BC_Write_Switch bit, 3-51
- AO_Board_Personalize function, 3-23
- AO_Channels function, 3-28
- AO_Configuration_End bit, 3-51
- AO_Configuration_Start bit, 3-51
- AO_Continuous bit, 3-52
- AO_Counting function, 3-24 to 3-26
- AO_DAC_i_Update_Mode bit, 3-52
- AO_Delayed_START1 bit, 3-52
- AO_Disarm bit, 3-52
- AO_DMA_PIO_Control bit, 3-53
- AO_End_On_BC_TC bit, 3-53
- AO_End_On_UC_TC bit, 3-53
- AO_END1 signal (table), 3-109
- AO_END2 signal (table), 3-109
- AO_Error_Interrupt_Ack bit, 3-53
- AO_Error_Interrupt_Enable bit, 3-53
- AO_Error_Second_Irq_Enable bit, 3-54
- AO_Errors_To_Stop_On function, 3-29
- AO_External_Gate_Enable bit, 3-54
- AO_External_Gate_Polarity bit, 3-54
- AO_External_Gate_Select bit, 3-54
- AO_External_Gate_St bit, 3-55
- AO_Fast_CPU bit, 3-55
- AO_FIFO_Empty_St bit, 3-55
- AO_FIFO_Enable bit, 3-55
- AO_FIFO_Flags_Polarity bit, 3-56
- AO_FIFO_Full_St bit, 3-56
- AO_FIFO function, 3-30
- AO_FIFO_Half_Full_St bit, 3-56
- AO_FIFO_Interrupt_Enable bit, 3-56
- AO_FIFO_Mode bit, 3-57
- AO_FIFO_Request_St bit, 3-57
- AO_FIFO_Retransmit_Enable bit, 3-57
- AO_FIFO_Second_Irq_Enable bit, 3-57
- AO_IN_TIMEBASE signal (table), 3-110

- AO_Interrupt_Install function, 3-30
- AO_Interval_Buffer_Mode bit, 3-58
- AO_LDAC_Source_And_Update_Mode function, 3-29
- AO_LDAC_i_Source_Select bit, 3-58
- AO_Multiple_Channels bit, 3-58
- AO_Mute_A bit, 3-58
- AO_Mute_B bit, 3-59
- AO_Not_An_UPDATE bit, 3-59
- AO_Number_Of_Channels bit, 3-59
- AO_Number_Of_DAC_Packages bit, 3-60
- AO_OUT_TIMEBASE signal (table), 3-110
- AO_Output_Divide_By_2 bit, 3-60
- AO_Overrun_St bit, 3-60
- AO_Rate_Change function, 3-34 to 3-35
- AO_Reset_All function, 3-21 to 3-22
- AO_Reset bit, 3-60 to 3-61
- AO_Software_Gate bit, 3-61
- AO_Source_Divide_By_2 bit, 3-61
- AO_Start_The_Generation function, 3-31
- AO_START_Edge bit, 3-61
- AO_START_Interrupt_Ack bit, 3-61
- AO_START_Interrupt_Enable bit, 3-62
- AO_START_Polarity bit, 3-62
- AO_START_Pulse bit, 3-62
- AO_START_Second_Irq_Enable bit, 3-62
- AO_START_Select bit, 3-62
- AO_START_St bit, 3-63
- AO_START_Stop_Gate_Enable bit, 3-63
- AO_START_Stop_Gate_St bit, 3-63
- AO_START_Sync bit, 3-63
- AO_START1_Disable bit, 3-63
- AO_START1_Edge bit, 3-64
- AO_START1_Interrupt_Ack bit, 3-64
- AO_START1_Interrupt_Enable bit, 3-64
- AO_START1_Polarity bit, 3-64
- AO_START1_Pulse bit, 3-64
- AO_START1_Second_Irq_Enable bit, 3-65
- AO_START1_Select bit, 3-65
- AO_START1_St bit, 3-65
- AO_START1_Sync bit, 3-65
- AO_STOP_Interrupt_Ack bit, 3-65
- AO_STOP_Interrupt_Enable bit, 3-66
- AO_Stop_On_BC_TC_Error bit, 3-66
- AO_Stop_On_BC_TC_Trigger_Error bit, 3-66
- AO_Stop_On_Overrun_Error bit, 3-66
- AO_STOP_Second_Irq_Enable bit, 3-67
- AO_STOP_St bit, 3-67
- AO_TMRDACWR_Pulse_Width bit, 3-67
- AO_TMRDACWRs_In_Progress_St bit, 3-67
- AO_Trigger_Length bit, 3-67
- AO_Trigger_Once bit, 3-68
- AO_Triggering function, 3-23 to 3-24
- AO_UC_Arm bit, 3-68
- AO_UC_Armed_St bit, 3-68
- AO_UC_Initial_Load_Source bit, 3-68
- AO_UC_Load_A bit, 3-68
- AO_UC_Load_B bit, 3-69
- AO_UC_Load bit, 3-68
- AO_UC_Next_Load_Source_St bit, 3-69
- AO_UC_Q_St bit, 3-69
- AO_UC_Save_St bit, 3-69
- AO_UC_Save_Trace bit, 3-69
- AO_UC_Save_Value bit, 3-70
- AO_UC_Switch_Load_Every_BC_TC bit, 3-70
- AO_UC_Switch_Load_Every_TC bit, 3-70
- AO_UC_Switch_Load_On_BC_TC bit, 3-70
- AO_UC_Switch_Load_On_TC bit, 3-70
- AO_UC_TC_Interrupt_Ack bit, 3-70
- AO_UC_TC_Interrupt_Enable bit, 3-71
- AO_UC_TC_Second_Irq_Enable bit, 3-71
- AO_UC_TC_St bit, 3-71
- AO_UC_Write_Switch bit, 3-71
- AO_UI_Arm bit, 3-71
- AO_UI_Armed_St bit, 3-72
- AO_UI_Count_Enabled_St bit, 3-72
- AO_UI_Initial_Load_Source bit, 3-72
- AO_UI_Load_A bit, 3-72
- AO_UI_Load_B bit, 3-73
- AO_UI_Load bit, 3-72

- AO_UI_Next_Load_Source_St bit, 3-73
- AO_UI_Q_St bit, 3-73
- AO_UI_Reload_Mode bit, 3-73
- AO_UI_Save_Value bit, 3-74
- AO_UI_Source_Polarity bit, 3-74
- AO_UI_Source_Select bit, 3-74
- AO_UI_Switch_Load_On_BC_TC bit, 3-74
- AO_UI_Switch_Load_On_Stop bit, 3-74
- AO_UI_Switch_Load_On_TC bit, 3-75
- AO_UI_Write_Switch bit, 3-75
- AO_UI2_Arm_Disarm bit, 3-75
- AO_UI2_Armed_St bit, 3-75
- AO_UI2_Configuration_End bit, 3-75
- AO_UI2_Configuration_Start bit, 3-75
- AO_UI2_Count_Enabled_St bit, 3-76
- AO_UI2_External_Gate_Enable bit, 3-76
- AO_UI2_External_Gate_Polarity bit, 3-76
- AO_UI2_External_Gate_Select bit, 3-76
- AO_UI2_Gate_St bit, 3-76
- AO_UI2_Initial_Load_Source bit, 3-76
- AO_UI2_Load_A bit, 3-77
- AO_UI2_Load_B bit, 3-77
- AO_UI2_Load bit, 3-77
- AO_UI2_Next_Load_Source_St bit, 3-77
- AO_UI2_Reload_Mode bit, 3-77
- AO_UI2_Save_Value bit, 3-77
- AO_UI2_Software_Gate bit, 3-78
- AO_UI2_Source_Polarity bit, 3-78
- AO_UI2_Source_Select bit, 3-78
- AO_UI2_Switch_Load_Next_TC bit, 3-78
- AO_UI2_TC_Error_Confirm bit, 3-78
- AO_UI2_TC_Error_St bit, 3-79
- AO_UI2_TC_Interrupt_Ack bit, 3-79
- AO_UI2_TC_Interrupt_Enable bit, 3-79
- AO_UI2_TC_Second_Irq_Enable bit, 3-79
- AO_UI2_TC_St bit, 3-79
- AO_UPDATE_Interrupt_Ack bit, 3-81
- AO_UPDATE_Interrupt_Enable bit, 3-81
- AO_UPDATE_Original_Pulse bit, 3-82
- AO_UPDATE_Output_Select bit, 3-82
- AO_UPDATE_Pulse bit, 3-82
- AO_UPDATE_Pulse_Timebase bit, 3-83
- AO_UPDATE_Pulse_Width bit, 3-83
- AO_UPDATE_Second_Irq_Enable bit, 3-83
- AO_UPDATE_Source_Polarity bit, 3-83
- AO_UPDATE_Source_Select bit, 3-84
- AO_UPDATE_St bit, 3-84
- AO_UPDATE2_Original_Pulse bit, 3-80
- AO_UPDATE2_Output_Select bit, 3-80
- AO_UPDATE2_Output_Toggle bit, 3-80
- AO_UPDATE2_Pulse bit, 3-80
- AO_UPDATE2_Pulse_Timebase bit, 3-81
- AO_UPDATE2_Pulse_Width bit, 3-81
- AO_Updating function, 3-26 to 3-28
- AO2_Arming function, 3-40
- AO2_Board_Personalize function, 3-39
- AO2_Counting function, 3-40
- AO2_Hardware_Gating function, 3-39
- AO2_Rate_Change function, 3-44 to 3-45
- AO2_Reset_All function, 3-38
- AOFEF* signal
 - DAQ-STC-driven analog output timing, 3-86 to 3-88
 - description (table), 3-16
 - FIFO data interface, 3-9
 - local buffer mode, 3-9 to 3-10
 - local buffer mode timing, 3-96 to 3-97
 - serial link data interface, 3-10
 - simplified analog output model, 3-5
 - unbuffered data interface, 3-11
 - unbuffered data interface timing, 3-98 to 3-100
- AOFFF* signal
 - DAQ-STC-driven analog output timing, 3-86
 - description (table), 3-17
 - simplified analog output model, 3-5
- AOFFRT* signal
 - description (table), 3-17
 - local buffer mode, 3-9 to 3-10

- local buffer mode timing, 3-96 to 3-97
- simplified analog output model, 3-4
- AOFHF* signal
 - DAQ-STC-driven analog output timing, 3-86
 - description (table), 3-17
 - simplified analog output model, 3-5
- AOFREQ signal
 - DAQ-STC-driven analog output timing, 3-86
 - description (table), 3-17
 - FIFO data interface, 3-8 to 3-9
 - simplified analog output model, 3-5
- AOTM. *See* analog output timing/control module.
- arming
 - analog input counters, 2-41
 - general-purpose counter/timer module, 4-18
 - primary analog output operation, 3-30 to 3-31
 - secondary analog output operation, 3-41

B

- BC counter
 - control circuitry, 3-120 to 3-121
 - description, 3-120
- BC_CE signal (table), 3-110
- BC_CLK signal (table), 3-110
- BC_DISARM signal (table), 3-110
- BC_HOLD signal (table), 3-110
- BC_LOAD signal (table), 3-110
- BC_LOAD_SRC signal (table), 3-110
- BC_SRC signal (table), 3-110
- BC_TC error, 3-123
- BC_TC signal
 - continuous-mode, 3-13 to 3-14
 - description (table), 3-17, 3-111
 - output timing (figure), 3-107
 - single-buffer mode, 3-13
- BC_TC trigger error, 3-123
- BD_i_Pin_Dir bit, 5-7
- bitfield descriptions
 - analog input timing/control, 2-48 to 2-83
 - AI_AIFREQ_Polarity, 2-48
 - AI_Analog_Trigger_Reset, 2-48
 - AI_Config_Memory_Empty_St, 2-49
 - AI_Configuration_End, 2-49
 - AI_Configuration_Start, 2-49
 - AI_Continuous, 2-49
 - AI_CONVERT_Original_Pulse, 2-50
 - AI_CONVERT_Output_Select, 2-50
 - AI_CONVERT_Pulse, 2-50
 - AI_CONVERT_Pulse_Timebase, 2-50
 - AI_CONVERT_Pulse_Width, 2-51
 - AI_CONVERT_Source_Polarity, 2-51
 - AI_CONVERT_Source_Select, 2-51
 - AI_Delay_START, 2-52
 - AI_Delayed_START, 2-51
 - AI_Delayed_START2, 2-52
 - AI_Disarm, 2-52
 - AI_DIV_Arm, 2-52
 - AI_DIV_Armed_St, 2-53
 - AI_DIV_Load, 2-53
 - AI_DIV_Load_A, 2-53
 - AI_DIV_Q_St, 2-53
 - AI_DIV_Save_Value, 2-53
 - AI_End_On_End_Of_Scan, 2-53
 - AI_End_On_SC_TC, 2-54
 - AI_EOC_Polarity, 2-54
 - AI_EOC_St, 2-54
 - AI_Error_Interrupt_Ack, 2-54
 - AI_Error_Interrupt_Enable, 2-54
 - AI_Error_Second_Irq_Enable, 2-54
 - AI_External_Gate_Mode, 2-55
 - AI_External_Gate_Polarity, 2-31, 2-55

AI_External_Gate_Select, 2-1, 2-55
 AI_External_Gate_St, 2-55
 AI_External_MUX_Present, 2-56
 AI_EXTMUX_CLK_Output_Select,
 2-56
 AI_EXTMUX_CLK_Pulse, 2-56
 AI_EXTMUX_CLK_Pulse_Width,
 2-56
 AI_FIFO_Empty_St, 2-57
 AI_FIFO_Flags_Polarity, 2-57
 AI_FIFO_Full_St, 2-57
 AI_FIFO_Half_Full_St, 2-57
 AI_FIFO_Interrupt_Enable, 2-58
 AI_FIFO_Mode, 2-58
 AI_FIFO_Request_St, 2-58
 AI_FIFO_Second_Irq_Enable, 2-59
 AI_Last_Shiftin_St, 2-59
 AI_LOCALMUX_CLK_Output_
 Select, 2-59
 AI_LOCALMUX_CLK_Pulse, 2-59
 AI_LOCALMUX_CLK_Pulse_
 Width, 2-59 to 2-60
 AI_Output_Divide_By_2, 2-60
 AI_Overflow_St, 2-60
 AI_Overrun_Mode, 2-60
 AI_Overrun_St, 2-60
 AI_Pre_Trigger, 2-61
 AI_Reset, 2-61
 AI_SC_Arm, 2-62
 AI_SC_Armed_St, 2-62
 AI_SC_Gate_Enable, 2-62
 AI_SC_Gate_St, 2-62
 AI_SC_Initial_Load_Source, 2-63
 AI_SC_Load, 2-63
 AI_SC_Load_A, 2-63
 AI_SC_Load_B, 2-63
 AI_SC_Next_Load_Source_St, 2-63
 AI_SC_Q_St, 2-64
 AI_SC_Reload_Mode, 2-64
 AI_SC_Save_St, 2-64
 AI_SC_Save_Trace, 2-64
 AI_SC_Save_Value, 2-64
 AI_SC_Switch_Load_On_TC, 2-65
 AI_SC_TC_Error_Confirm, 2-65
 AI_SC_TC_Error_St, 2-65
 AI_SC_TC_Interrupt_Ack, 2-65
 AI_SC_TC_Interrupt_Enable, 2-65
 AI_SC_TC_Output_Select, 2-66
 AI_SC_TC_Pulse, 2-66
 AI_SC_TC_Second_Irq_Enable,
 2-66
 AI_SC_TC_St, 2-66
 AI_SC_Write_Switch, 2-66
 AI_SCAN_IN_PROG_Output_
 Select, 2-61
 AI_SCAN_IN_PROG_Pulse, 2-62
 AI_Scan_In_Progress_St, 2-61
 AI_SHIFTIN_Polarity, 2-67
 AI_SHIFTIN_Pulse_Width, 2-67
 AI_SI_Armed_St, 2-67
 AI_SI_Count_Enabled_St, 2-67
 AI_SI_Initial_Load_Source, 2-68
 AI_SI_Load, 2-68
 AI_SI_Load_A, 2-68
 AI_SI_Load_B, 2-68
 AI_SI_Next_Load_Source_St, 2-68
 AI_SI_Q_St, 2-69
 AI_SI_Reload_Mode, 2-69
 AI_SI_Save_Value, 2-69
 AI_SI_Source_Polarity, 2-69
 AI_SI_Source_Select, 2-70
 AI_SI_Special_Trigger_Delay, 2-70
 AI_SI_Switch_Load_On_SC_TC,
 2-70
 AI_SI_Switch_Load_On_Stop, 2-70
 AI_SI_Switch_Load_On_TC, 2-70
 AI_SI_Write_Switch, 2-71
 AI_SI2_Arm, 2-71
 AI_SI2_Armed_St, 2-71
 AI_SI2_Initial_Load_Source, 2-71
 AI_SI2_Load, 2-71
 AI_SI2_Load_A, 2-71

AI_SI2_Load_B, 2-72
 AI_SI2_Next_Load_Source_St, 2-72
 AI_SI2_Q_St, 2-72
 AI_SI2_Reload_Mode, 2-72
 AI_SI2_Save_Value, 2-72
 AI_SI2_Source_Select, 2-73
 AI_SOC_Polarity, 2-73
 AI_SOC_St, 2-73
 AI_Software_Gate, 2-73
 AI_Source_Divide_By_2, 2-73
 AI_START_Edge, 2-74
 AI_START_Interrupt_Ack, 2-74
 AI_START_Interrupt_Enable, 2-74
 AI_START_Output_Select, 2-74
 AI_START_Polarity, 2-74
 AI_START_Pulse, 2-75
 AI_START_Second_Irq_Enable,
 2-75
 AI_START_Select, 2-75
 AI_START_St, 2-75
 AI_Start_Stop, 2-76
 AI_Start_Stop_Gate_Enable, 2-76
 AI_Start_Stop_Gate_St, 2-76
 AI_START_Sync, 2-76
 AI_START1_Disable, 2-76
 AI_START1_Edge, 2-77
 AI_START1_Interrupt_Ack, 2-77
 AI_START1_Interrupt_Enable, 2-77
 AI_START1_Polarity, 2-77
 AI_START1_Pulse, 2-77
 AI_START1_Second_Irq_Enable,
 2-78
 AI_START1_Select, 2-78
 AI_START1_St, 2-78
 AI_START1_Sync, 2-78
 AI_START2_Edge, 2-79
 AI_START2_Interrupt_Ack, 2-79
 AI_START2_Interrupt_Enable, 2-79
 AI_START2_Interrupt_Polarity,
 2-79
 AI_START2_Interrupt_Pulse, 2-79
 AI_START2_Second_Irq_Enable,
 2-80
 AI_START2_Select, 2-80
 AI_START2_St, 2-80
 AI_START2_Sync, 2-80
 AI_STOP_Edge, 2-81
 AI_STOP_Interrupt_Ack, 2-81
 AI_STOP_Interrupt_Enable, 2-81
 AI_STOP_Polarity, 2-81
 AI_STOP_Pulse, 2-81
 AI_STOP_Second_Irq_Enable, 2-82
 AI_STOP_Select, 2-82
 AI_STOP_St, 2-82
 AI_STOP_Sync, 2-83
 AI_Trigger_Length, 2-83
 AI_Trigger_Once, 2-83
 analog output timing/control, 3-45 to 3-84
 AO_Analog_Trigger_Reset, 3-45
 AO_AOFREQ_Enable, 3-46
 AO_AOFREQ_Polarity, 3-46
 AO_BC_Arm, 3-46
 AO_BC_Armed_St, 3-46
 AO_BC_Gate_Enable, 3-46
 AO_BC_Gate_St, 3-47
 AO_BC_Initial_Load_Source, 3-47
 AO_BC_Load, 3-47
 AO_BC_Load_A, 3-47
 AO_BC_Load_B, 3-47
 AO_BC_Next_Load_Source, 3-48
 AO_BC_Q_St, 3-48
 AO_BC_Reload_Mode, 3-48
 AO_BC_Save_St, 3-48
 AO_BC_Save_Trace, 3-48
 AO_BC_Save_Value, 3-49
 AO_BC_Source_Select, 3-49
 AO_BC_Switch_Load_On_TC, 3-49
 AO_BC_TC_Error_Confirm, 3-49
 AO_BC_TC_Error_St, 3-49
 AO_BC_TC_Interrupt_Ack, 3-50
 AO_BC_TC_Interrupt_Enable, 3-50

- AO_BC_TC_Second_Irq_Enable, 3-50
- AO_BC_TC_St, 3-50
- AO_BC_TC_Trigger_Error_Confirm, 3-50
- AO_BC_TC_Trigger_Error_St, 3-51
- AO_BC_Write_Switch, 3-51
- AO_Configuration_End, 3-51
- AO_Configuration_Start, 3-51
- AO_Continuous, 3-52
- AO_DAC_i Update_Mode, 3-52
- AO_Delayed_START1, 3-52
- AO_Disarm, 3-52
- AO_DMA_PIO_Control, 3-53
- AO_End_On_BC_TC, 3-53
- AO_End_On_UC_TC, 3-53
- AO_Error_Interrupt_Ack, 3-53
- AO_Error_Interrupt_Enable, 3-53
- AO_Error_Second_Irq_Enable, 3-54
- AO_External_Gate_Enable, 3-54
- AO_External_Gate_Polarity, 3-54
- AO_External_Gate_Select, 3-54
- AO_External_Gate_St, 3-55
- AO_Fast_CPU, 3-55
- AO_FIFO_Empty_St, 3-55
- AO_FIFO_Enable, 3-55
- AO_FIFO_Flags_Polarity, 3-56
- AO_FIFO_Full_St, 3-56
- AO_FIFO_Half_Full_St, 3-56
- AO_FIFO_Interrupt_Enable, 3-56
- AO_FIFO_Mode, 3-57
- AO_FIFO_Request_St, 3-57
- AO_FIFO_Retransmit_Enable, 3-57
- AO_FIFO_Second_Irq_Enable, 3-57
- AO_Interval_Buffer_Mode, 3-58
- AO_LDAC_i Source_Select, 3-58
- AO_Multiple_Channels, 3-58
- AO_Mute_A, 3-58
- AO_Mute_B, 3-59
- AO_Not_An_UPDATE, 3-59
- AO_Number_Of_Channels, 3-59
- AO_Number_Of_DAC_Packages, 3-60
- AO_Output_Divide_By_2, 3-60
- AO_Overrun_St, 3-60
- AO_Reset, 3-60 to 3-61
- AO_Software_Gate, 3-61
- AO_Source_Divide_By_2, 3-61
- AO_START_Edge, 3-61
- AO_START_Interrupt_Ack, 3-61
- AO_START_Interrupt_Enable, 3-62
- AO_START_Polarity, 3-62
- AO_START_Pulse, 3-62
- AO_START_Second_Irq_Enable, 3-62
- AO_START_Select, 3-62
- AO_START_St, 3-63
- AO_START_Stop_Gate_Enable, 3-63
- AO_START_Stop_Gate_St, 3-63
- AO_START_Sync, 3-63
- AO_START1_Disable, 3-63
- AO_START1_Edge, 3-64
- AO_START1_Interrupt_Ack, 3-64
- AO_START1_Interrupt_Enable, 3-64
- AO_START1_Polarity, 3-64
- AO_START1_Pulse, 3-64
- AO_START1_Second_Irq_Enable, 3-65
- AO_START1_Select, 3-65
- AO_START1_St, 3-65
- AO_START1_Sync, 3-65
- AO_STOP_Interrupt_Ack, 3-65
- AO_STOP_Interrupt_Enable, 3-66
- AO_Stop_On_BC_TC_Error, 3-66
- AO_Stop_On_BC_TC_Trigger_Error, 3-66
- AO_Stop_On_Overrun_Error, 3-66
- AO_STOP_Second_Irq_Enable, 3-67
- AO_STOP_St, 3-67

AO_TMRDACWR_Pulse_Width, 3-67
 AO_TMRDACWRs_In_Progress_St, 3-67
 AO_Trigger_Length, 3-67
 AO_Trigger_Once, 3-68
 AO_UC_Arm, 3-68
 AO_UC_Armed_St, 3-68
 AO_UC_Initial_Load_Source, 3-68
 AO_UC_Load, 3-68
 AO_UC_Load_A, 3-68
 AO_UC_Load_B, 3-69
 AO_UC_Next_Load_Source_St, 3-69
 AO_UC_Q_St, 3-69
 AO_UC_Save_St, 3-69
 AO_UC_Save_Trace, 3-69
 AO_UC_Save_Value, 3-70
 AO_UC_Switch_Load_Every_BC_TC, 3-70
 AO_UC_Switch_Load_Every_TC, 3-70
 AO_UC_Switch_Load_On_BC_TC, 3-70
 AO_UC_Switch_Load_On_TC, 3-70
 AO_UC_TC_Interrupt_Ack, 3-70
 AO_UC_TC_Interrupt_Enable, 3-71
 AO_UC_TC_Second_Irq_Enable, 3-71
 AO_UC_TC_St, 3-71
 AO_UC_Write_Switch, 3-71
 AO_UI_Arm, 3-71
 AO_UI_Armed_St, 3-72
 AO_UI_Count_Enabled_St, 3-72
 AO_UI_Initial_Load_Source, 3-72
 AO_UI_Load, 3-72
 AO_UI_Load_A, 3-72
 AO_UI_Load_B, 3-73
 AO_UI_Next_Load_Source_St, 3-73
 AO_UI_Q_St, 3-73
 AO_UI_Reload_Mode, 3-73
 AO_UI_Save_Value, 3-74
 AO_UI_Source_Polarity, 3-74
 AO_UI_Source_Select, 3-74
 AO_UI_Switch_Load_On_BC_TC, 3-74
 AO_UI_Switch_Load_On_Stop, 3-74
 AO_UI_Switch_Load_On_TC, 3-75
 AO_UI_Write_Switch, 3-75
 AO_UI2_Arm_Disarm, 3-75
 AO_UI2_Armed_St, 3-75
 AO_UI2_Configuration_End, 3-75
 AO_UI2_Configuration_Start, 3-75
 AO_UI2_Count_Enabled_St, 3-76
 AO_UI2_External_Gate_Enable, 3-76
 AO_UI2_External_Gate_Polarity, 3-76
 AO_UI2_External_Gate_Select, 3-76
 AO_UI2_Gate_St, 3-76
 AO_UI2_Initial_Load_Source, 3-76
 AO_UI2_Load, 3-77
 AO_UI2_Load_A, 3-77
 AO_UI2_Load_B, 3-77
 AO_UI2_Next_Load_Source_St, 3-77
 AO_UI2_Reload_Mode, 3-77
 AO_UI2_Save_Value, 3-77
 AO_UI2_Software_Gate, 3-78
 AO_UI2_Source_Polarity, 3-78
 AO_UI2_Source_Select, 3-78
 AO_UI2_Switch_Load_Next_TC, 3-78
 AO_UI2_TC_Error_Confirm, 3-78
 AO_UI2_TC_Error_St, 3-79
 AO_UI2_TC_Interrupt_Ack, 3-79
 AO_UI2_TC_Interrupt_Enable, 3-79
 AO_UI2_TC_Second_Irq_Enable, 3-79

- AO_UI2_TC_St, 3-79
- AO_UPDATE_Interrupt_Ack, 3-81
- AO_UPDATE_Interrupt_Enable, 3-81
- AO_UPDATE_Original_Pulse, 3-82
- AO_UPDATE_Output_Select, 3-82
- AO_UPDATE_Pulse, 3-82
- AO_UPDATE_Pulse_Timebase, 3-83
- AO_UPDATE_Pulse_Width, 3-83
- AO_UPDATE_Second_Irq_Enable, 3-83
- AO_UPDATE_Source_Polarity, 3-83
- AO_UPDATE_Source_Select, 3-84
- AO_UPDATE_St, 3-84
- AO_UPDATE2_Original_Pulse, 3-80
- AO_UPDATE2_Output_Select, 3-80
- AO_UPDATE2_Output_Toggle, 3-80
- AO_UPDATE2_Pulse, 3-80
- AO_UPDATE2_Pulse_Timebase, 3-81
- AO_UPDATE2_Pulse_Width, 3-81
- bus interface module, 9-4 to 9-5
 - Software_Reset, 9-4
 - Software_Test, 9-4
 - Window_Address, 9-5
 - Window_Data, 9-5
 - Write_Strobe_0, 9-5
 - Write_Strobe_1, 9-5
 - Write_Strobe_2, 9-5
 - Write_Strobe_3, 9-5
- digital I/O, 7-13 to 7-15
 - Control, 7-13
 - DIO_HW_Serial_Enable, 7-13
 - DIO_HW_Serial_Start, 7-13
 - DIO_HW_Serial_Timebase, 7-14
 - DIO_Parallel_Data_In_St, 7-14
 - DIO_Parallel_Data_Out, 7-14
 - DIO_Pins_Dir, 7-14
 - DIO_Serial_Data_In_St, 7-14
 - DIO_Serial_Data_Out, 7-14
 - DIO_Serial_IO_In_Progress_St, 7-15
 - DIO_Serial_Out_Divide_By_2, 7-15
 - DIO_Software_Serial_Control, 7-15
 - Generic_Status, 7-15
 - general-purpose counter/timer, 4-35 to 4-52
 - G_Source_Divide_By_2, 4-52
 - Gi_Analog_Trigger_Reset, 4-35
 - Gi_Arm, 4-36
 - Gi_Arm_Copy, 4-36
 - Gi_Armed_St, 4-36
 - Gi_Autoincrement, 4-36
 - Gi_Bank_St, 4-36
 - Gi_Bank_Switch_Enable, 4-37
 - Gi_Bank_Switch_Mode, 4-37
 - Gi_Bank_Switch_Start, 4-37
 - Gi_Counting_Once, 4-37
 - Gi_Counting_St, 4-38
 - Gi_Disarm, 4-38
 - Gi_Disarm_Copy, 4-38
 - Gi_Gate_Error_Confirm, 4-38
 - Gi_Gate_Error_St, 4-38
 - Gi_Gate_Interrupt_Act, 4-39
 - Gi_Gate_Interrupt_Enable, 4-39
 - Gi_Gate_Interrupt_St, 4-39
 - Gi_Gate_On_Both_Edges, 4-39
 - Gi_Gate_Polarity, 4-40
 - Gi_Gate_Second_Irq_Enable, 4-40
 - Gi_Gate_Select, 4-40
 - Gi_Gate_Select_Load_Source, 4-41
 - Gi_Gate_St, 4-41
 - Gi_Gating_Mode, 4-41
 - Gi_HW_Save_St, 4-42
 - Gi_HW_Save_Value, 4-42
 - Gi_Little_Big_Endian, 4-42
 - Gi_Load, 4-42
 - Gi_Load_A, 4-43
 - Gi_Load_B, 4-43

- Gi_Load_Source_Select, 4-43
- Gi_Loading_On_Gate, 4-44
- Gi_Loading_On_TC, 4-44
- Gi_Next_Load_Source_St, 4-44
- Gi_No_Load_Between_Gates_St, 4-44
- Gi_OR_Gate, 4-45
- Gi_Output_Mode, 4-45
- Gi_Output_Polarity, 4-45
- Gi_Output_St, 4-45
- Gi_Permanent_State_Data_St, 4-46
- Gi_Read_Acknowledges_Irq, 4-46
- Gi_Reload_Source_Switching, 4-46
- Gi_Reset, 4-46
- Gi_Save_Copy, 4-47
- Gi_Save_St, 4-47
- Gi_Save_Trace, 4-47
- Gi_Save_Value, 4-47
- Gi_Source_Polarity, 4-48
- Gi_Source_Select, 4-48
- Gi_Stale_Data_St, 4-48
- Gi_Stop_Mode, 4-48
- Gi_Synchronized_Gate, 4-49
- Gi_TC_Error_Confirm, 4-49
- Gi_TC_Error_St, 4-49
- Gi_TC_Interrupt_Ack, 4-49
- Gi_TC_Interrupt_Enable, 4-50
- Gi_TC_Second_Irq_Enable, 4-50
- Gi_TC_St, 4-50
- Gi_Trigger_Mode_For_Edge_Gate, 4-50
- Gi_Up_Down, 4-51
- Gi_Write_Acknowledges_Irq, 4-51
- Gi_Write_Switch, 4-51
- GPFO_0_Output_Enable, 4-51
- GPFO_0_Output_Select, 4-52
- GPFO_1_Output_Enable, 4-52
- GPFO_1_Output_Select, 4-52
- interrupt control, 8-12 to 8-14
 - Interrupt_A_Enable, 8-12
 - Interrupt_A_Output_Select, 8-12
 - Interrupt_A_St, 8-13
 - Interrupt_B_Enable, 8-13
 - Interrupt_B_Output_Select, 8-13
 - Interrupt_B_St, 8-13
 - Interrupt_Output_On_3_Pins, 8-13
 - Interrupt_Output_Polarity, 8-13
 - Pass_Thru_i_Interrupt_Enable, 8-14
 - Pass_Thru_i_Interrupt_Polarity, 8-14
 - Pass_Thru_i_Interrupt_St, 8-14
 - Pass_Thru_i_Second_Irq_Enable, 8-14
- miscellaneous functions, 10-12 to 10-15
 - Analog_Trigger_Drive, 10-12
 - Analog_Trigger_Enable, 10-13
 - Analog_Trigger_Mode, 10-13
 - Clock_To_Board, 10-13
 - Clock_To_Board_Divide_By_2, 10-13
 - FOUT_Divider, 10-13
 - FOUT_Enable, 10-14
 - FOUT_Timebase_Select, 10-14
 - Misc_Counter_TCs_Output_Enable, 10-14
 - Reserved_One, 10-14
 - Slow_Internal_Time_Divide_By_2, 10-14
 - Slow_Internal_Timebase, 10-15
- PFI module, 5-6 to 5-7
 - BD_i_Pin_Dir, 5-7
- RTSI trigger module, 6-3 to 6-5
 - RTSI_Board_i_Output_Select, 6-4
 - RTSI_Board_i_Pin_Dir, 6-4
 - RTSI_Clock_Mode, 6-4
 - RTSI_Sub_Selection_1, 6-5
 - RTSI_Trig_i_Output_Select, 6-5
 - RTSI_Trig_i_Pin_Dir, 6-5
- bitfields
 - analog input programming considerations, 2-24
 - guide to location in manual (table), B-9
- block diagram for DAQ-STC, 1-4

- board environment setup, analog input programming, 2-29 to 2-30
- board power-up initialization
 - analog input programming, 2-27 to 2-28
 - primary analog output operation, 3-22 to 3-23
 - secondary analog output operation, 3-39
- buffer timing and control for primary analog output, 3-12 to 3-16
 - continuous mode, 3-13 to 3-14
 - master/slave trigger, 3-15 to 3-16
 - mute buffers, 3-15
 - single-buffer mode, 3-13
 - waveform staging, 3-14 to 3-15
- buffered event counting
 - cumulative, 4-5
 - noncumulative, 4-4 to 4-5
 - programming, 4-20 to 4-22
- Buffered_Period_And_Semi_Period_And_Pulse_Width_Measurement function, 4-26 to 4-27
- buffered period measurement, 4-7 to 4-8
- buffered pulse-train generation, 4-14
- buffered pulsewidth measurement, 4-9
- buffered retriggerable single pulse generation, 4-11 to 4-12
- buffered semiperiod measurement, 4-8
- buffered static pulse-train generation, 4-13
- buffers, number of, primary analog output operation, 3-24 to 3-26
- bulletin board support, E-1
- bus interface module, 9-1 to 9-8
 - features, 9-1
 - overview, 9-1
 - pin interface, 9-1 to 9-3
 - programming information, 9-3 to 9-5
 - bitfield descriptions, 9-4 to 9-5
 - write strobes, 9-4
 - timing diagrams, 9-5 to 9-8
 - Intel bus interface read timing (figure), 9-6

- Intel bus interface timing (table), 9-6 to 9-7
- Intel bus interface write timing (figure), 9-6
- Motorola bus interface read timing (figure), 9-7
- Motorola bus interface timing (table), 9-8
- Motorola bus interface write timing (figure), 9-8

C

- channel selection, primary analog output operation, 3-28
- CHRDY_IN signal (table), 9-2
- CHRDY_OUT signal
 - bus interface (table), 9-2
 - CPU-driven analog output, 3-6 to 3-7
 - CPU-driven analog output timing, 3-88 to 3-89
 - unbuffered data interface timing, 3-98 to 3-100
- clock distribution, 10-2 to 10-3
 - master/slave distribution across RTSI bus (figure), 10-2
 - programming, 10-10 to 10-11
 - timebases derived from IN_TIMEBASE (table), 10-2 to 10-3
- Clock_To_Board bit, 10-13
- Clock_To_Board_Divide_By_2 bit, 10-13
- configuration FIFO control, 2-7 to 2-9
- configuration memory output, initializing, 2-28 to 2-29
- configuration memory timing, 2-89 to 2-91
 - related signals (figure), 2-89
 - timing (table), 2-90
- continuous acquisition mode, 2-15
- continuous mode, buffer timing and control, primary analog output, 3-13 to 3-14
- Continuous_Pulse_Train_Generation function, 4-30 to 4-31

- continuous pulse-train generation
 - description, 4-12 to 4-13
 - programming, 4-28 to 4-31
- control lines, digital I/O, 7-12
- conventions used in manual, xxv
- CONVERT* signal
 - basic analog input timing, 2-86 to 2-87
 - configuration memory timing, 2-89 to 2-90
 - description (table), 2-20
 - external gating, 2-109 to 2-111
 - gating, 2-16
 - interval scanning mode, 2-106 to 2-108
 - low-level timing and control functions, 2-6 to 2-11
 - ADC control, 2-7
 - configuration FIFO and external multiplexer control, 2-7 to 2-9
 - CONVERT timing, 2-9 to 2-11
 - Data FIFO control, 2-7
 - nominal pulsewidths (table), 2-133
 - selecting with AI_CONVERT_Signal function, 2-38 to 2-40
 - simplified analog input model, 2-4 to 2-6
 - single-wire mode, 2-18
- CONVERT_SRC signal
 - basic analog input timing, 2-86
 - external CONVERT source, 2-92 to 2-93
 - external gating, 2-110
 - external trigger timing, 2-93 to 2-97
 - internal CONVERT mode, 2-9 to 2-10
 - reference pin selection (table), 2-84 to 2-85
- CONVERT timing. *See* external CONVERT mode; internal CONVERT mode.
- counter contents, reading, 4-34
- counter outputs
 - analog input timing/control module
 - DIV_TC signal (figure), 2-106
 - SC_TC signal (figure), 2-105
 - SI_TC signal (figure), 2-105
 - analog output timing/control module, 3-107 to 3-108
 - BC_TC signal (figure), 3-107
 - UC_TC signal (figure), 3-108
- counters
 - analog input timing/control module, 2-123 to 2-130
 - DIV control, 2-129 to 2-130
 - DIV counter, 2-128
 - SC control, 2-123 to 2-125
 - SC counter, 2-123
 - SI control, 2-126 to 2-127
 - SI counter, 2-126
 - SI2 control, 2-127 to 2-128
 - SI2 counter, 2-127
 - analog output timing/control module, 3-117 to 3-121
 - BC control, 3-120 to 3-121
 - BC counter, 3-120
 - UC control, 3-119
 - UC counter, 3-118 to 3-119
 - UI control, 3-118
 - UI counter, 3-117
 - UI2 control, 3-121
 - UI2 counter, 3-121
- counter/timer. *See* general-purpose counter/timer.
- counter/timer functions, 4-3 to 4-15
 - event counting, 4-3 to 4-6
 - buffered cumulative event counting, 4-5
 - buffered noncumulative event counting, 4-4 to 4-5
 - relative position sensing, 4-6
 - simple event counting, 4-4
 - simple gated-event counting, 4-4
 - pulse generation, 4-9 to 4-12
 - buffered retriggerable single pulse generation, 4-11 to 4-12
 - retriggerable single pulse generation, 4-11

- single pulse generation, 4-9 to 4-10
 - single triggered pulse generation, 4-10
- pulse-train generation, 4-12 to 4-15
 - buffered pulse-train generation, 4-14
 - buffered static pulse-train generation, 4-13
 - continuous pulse-train generation, 4-12 to 4-13
 - frequency shifting keying (FSK), 4-14 to 4-15
 - pulse generation for ETS, 4-15
- time measurement, 4-6 to 4-9
 - buffered period measurement, 4-7 to 4-8
 - buffered pulsewidth measurement, 4-9
 - buffered semiperiod measurement, 4-8
 - single-period measurement, 4-6 to 4-7
 - single-pulsewidth measurement, 4-7
- CPUDACREQ* signal
 - CPU-driven analog output, 3-6 to 3-7
 - CPU-driven analog output timing, 3-88 to 3-90
 - DAQ-STC- and CPU-driven analog output timing, 3-91 to 3-92
 - description (table), 3-17
 - simplified analog output model, 3-4
 - unbuffered data interface timing, 3-98 to 3-100
- CPUDACWR* signal
 - CPU-driven analog output, 3-6 to 3-7
 - CPU-driven analog output timing, 3-88 to 3-90
 - description (table), 3-18
 - maximum update rate timing, 3-101
 - simplified analog output model, 3-4
 - unbuffered data interface, 3-11
 - unbuffered data interface timing, 3-98 to 3-100
 - CPU-driven analog output, 3-6 to 3-7
 - CPU-driven analog output timing, 3-88 to 3-90
 - CS* signal (table), 9-2
 - CTR_U/D reference pin selection (table), 4-54
 - CTRGATE reference pin selection (table), 4-54
 - CTRL<0..7> signal (table), 7-6
 - CTRSRC signal
 - CTRSRC to CTROUT delay, 4-55 to 4-56
 - minimum period and minimum pulsewidth (figure), 4-55
 - reference pin selection (table), 4-53
 - customer communication, xxvii, E-1 to E-2
- D**
 - D<0..15> signal (table), 9-2
 - DA_ST1ED signal (table), 3-111
 - DA_START1 signal (table), 3-111
 - DAC interface, 3-8
 - DACUPDN signal (table), 3-111
 - DACWR*<0..1> signal
 - DAC interface, 3-8
 - decoded signal timing, 3-94 to 3-95
 - description (table), 3-18
 - simplified analog output model, 3-5
 - DAQ-STC
 - applications, 1-2 to 1-4
 - analog input, 1-2 to 1-3
 - analog output, 1-3 to 1-4
 - block diagram, 1-4
 - features, 1-1
 - overview, 1-1
 - revision history, D-1 to D-2
 - DAQ-STC and CPU conflict, 3-7
 - DAQ-STC- and CPU-driven analog output timing, 3-90 to 3-92
 - DAQ-STC registers. *See* registers.
 - DAQ-STC-driven analog output, 3-6

- DAQ-STC-driven analog output timing,
 - 3-86 to 3-88
 - signal names and clock periods (table), 3-87 to 3-88
 - signal timing (figure), 3-87
- data FIFOs, 2-88 to 2-89
 - configuration memory timing (table), 2-89
 - control signals, 2-7
 - signal timing (figure), 2-88
- data interfaces, 3-8 to 3-11
 - FIFO data interface, 3-8 to 3-10
 - serial link data interface, 3-10
 - unbuffered data interface, 3-11
- DC characteristics specifications, A-3 to A-4
- decoded signal timing, 3-94 to 3-95
- digital I/O, 7-1 to 7-17
 - detailed description, 7-17
 - features, 7-1
 - overview, 7-1
 - parallel mode, 7-2 to 7-3
 - parallel input, 7-3
 - parallel output, 7-3
 - pin interface, 7-6 to 7-7
 - programming information, 7-7 to 7-15
 - bitfield descriptions, 7-13 to 7-15
 - control lines, 7-12
 - hardware-controlled serial digital I/O, 7-10 to 7-12
 - parallel digital I/O, 7-9
 - programming the digital interface, 7-8 to 7-9
 - reading status lines, 7-13
 - software-controlled serial digital I/O, 7-12
 - windowed mode register access
 - example, 7-7 to 7-8
 - serial mode, 7-4 to 7-5
 - serial input, 7-4
 - serial I/O, 7-5
 - serial output, 7-4 to 7-5
 - serial output source select (table), 7-17
 - simplified model, 7-1 to 7-2
 - specifications, A-1
 - timing diagrams, 7-15 to 7-16
 - serial input timing, 7-15 to 7-16
 - serial output timing, 7-16
- DIO<1..3> signal (table), 7-6
- DIO<5..7> signal (table), 7-6
- DIO_Clock_Out function, 7-12
- DIO_HW_Serial_Enable bit, 7-13
- DIO_HW_Serial_Initialize function, 7-10 to 7-11
- DIO_HW_Serial_Start bit, 7-13
- DIO_HW_Serial_Timebase bit
 - description, 7-14
 - serial output source select (table), 7-17
- DIO_Parallel_Data_In_St bit, 7-14
- DIO_Parallel_Data_Out bit, 7-14
- DIO_Parallel_Out function, 7-2
- DIO_Pin_Configure function, 7-9
- DIO_Pins_Dir bit, 7-14
- DIO_Serial_Data_In_St bit, 7-14
- DIO_Serial_Data_Out bit, 7-14
- DIO_Serial_Data_Out function, 7-10
- DIO_Serial_In function, 7-11
- DIO_Serial_IO_In_Progress_St bit, 7-15
- DIO_Serial_Out_Divide_By_2 bit, 7-15
- DIO_Software_Serial_Control bit, 7-15
- DIO0/SDOUT signal (table), 7-6
- DIO4/SDIN signal (table), 7-6
- DIV counter
 - control circuitry, 2-129 to 2-130
 - description, 2-128
- DIV_CE signal
 - description (table), 2-114
 - DIV counter operation, 2-129
- DIV_CLK signal (table), 2-114
- DIV_DISARM signal, DIV counter operation, 2-129

- DIV_LOAD signal
 - description (table), 2-114
 - DIV counter operation, 2-129
- DIV_TC signal
 - counter outputs (figure), 2-106
 - description (table), 2-114
 - pin interface description (table), 2-20
- documentation
 - about this manual, *xxiii*
 - conventions used in manual, *xxv*
 - National Instruments documentation, *xxvi*
 - organization of manual, *xxiii-xxiv*
 - related documentation, *xxvi-xxvii*
- E**
- edge detection, trigger selection and conditioning
 - analog input timing/control module, 2-122
 - analog output timing/control module, 3-116
- electronic support services, E-1 to E-2
- e-mail support, E-2
- Enable_Gi_Out function, 4-35
- end of scan, analog input programming, 2-37 to 2-38
- EOC signal
 - ADC control, 2-7
 - basic analog input timing, 2-86
 - description (table), 2-21
 - simplified analog input model, 2-5
- error detection
 - analog input timing/control module
 - overflow error, 2-132
 - overrun error, 2-132
 - ST_TC error, 2-132
 - analog output timing/control module, 3-122 to 3-123
 - BC_TC error, 3-123
 - BC_TC trigger error, 3-123
 - overrun error, 3-122
 - UI2_TC error, 3-123
- ETS, pulse generation for
 - description, 4-15
 - programming, 4-33 to 4-34
- event counting, 4-3 to 4-6
 - buffered cumulative event counting, 4-5
 - buffered noncumulative event counting, 4-4 to 4-5
 - programming
 - buffered event counting, 4-20 to 4-22
 - relative position sensing, 4-23 to 4-24
 - simple event counting, 4-19 to 4-20
 - relative position sensing, 4-6
 - simple event counting, 4-4
 - simple gated-event counting, 4-4
- Event_Counting_ISR function, 4-22
- EXT_DIVTC signal (table), 2-114
- EXT_GATE signal
 - analog input timing/control
 - description (table), 2-114
 - trigger routing logic (figure), 2-121
 - analog output timing/control
 - description (table), 3-111
 - routing logic (figure), 3-115
- EXT_GATE2 signal
 - description (table), 3-111
 - routing logic (figure), 3-115
- external CONVERT mode
 - CONVERT timing, 2-10 to 2-11
 - free-run gating mode timing, external CONVERT (figure), 2-110
 - START and SCAN_IN_PROG trigger output, 2-102
 - START trigger output, 2-102
 - START1 and START2 triggers in synchronous mode, 2-97 to 2-99
- external CONVERT source, 2-92 to 2-93
- external gating. *See* gating.
- external multiplexer control, 2-7 to 2-9

- external START mode, scan-level timing and control, 2-12 to 2-13
 - external trigger timing, 3-102 to 3-104
 - asynchronous edge (figure), 3-102
 - asynchronous level (figure), 3-102
 - synchronous edge
 - external UPDATE mode (figure), 3-103
 - internal UPDATE mode (figure), 3-103
 - synchronous level
 - external UPDATE mode (figure), 3-103
 - internal UPDATE mode (figure), 3-103
 - timing (table), 3-104
 - external triggers, 2-93 to 2-97
 - analog input timing (table), 2-96 to 2-97
 - asynchronous edge (figure), 2-94
 - asynchronous level (figure), 2-94
 - synchronous edge
 - external CONVERT mode (figure), 2-96
 - internal CONVERT mode (figure), 2-95
 - synchronous level
 - external CONVERT mode (figure), 2-96
 - internal CONVERT mode (figure), 2-95
 - external UPDATE
 - external trigger timing
 - synchronous edge (figure), 3-103
 - synchronous level (figure), 3-103
 - primary analog output, 3-12
 - trigger output, START1 delays, synchronous mode (figure), 3-106
 - EXTMUX_CLK signal
 - configuration FIFO control and external multiplexer control, 2-8
 - configuration memory timing, 2-89 to 2-91
 - description (table), 2-21
 - nominal pulsewidths (table), 2-133
 - simplified analog input model, 2-5
 - EXTSTROBE signal
 - configuration memory timing, 2-89 to 2-91
 - nominal pulsewidths (table), 2-133
 - EXTSTROBE*/SDCLK signal
 - description (table), 7-7
 - parallel mode
 - parallel input, 7-3
 - parallel output, 7-3
 - serial input timing (figure), 7-16
 - serial mode
 - hardware-controlled serial digital I/O, 7-10 to 7-12
 - serial input, 7-4
 - serial I/O, 7-5
 - serial output, 7-4 to 7-5
 - software-controlled serial digital I/O, 7-12
 - serial output timing (figure), 7-16
- ## F
- fax and telephone support numbers, E-2
 - Fax-on-Demand support, E-2
 - FIFO
 - configuration FIFO control, 2-7 to 2-9
 - data FIFOs, 2-7, 2-88 to 2-89
 - data interface mode, 3-8 to 3-10
 - FIFO mode selection, 3-29 to 3-30
 - FIFO_Request_Selection function, 2-30
 - FOUT_Divider bit, 10-13
 - FOUT_Enable bit, 10-14
 - FOUT signal
 - description (table), 10-10
 - programming, 10-12
 - purpose and use, 10-3

FOUT_Timebase_Select bit, 10-14
 free-run gating mode
 theory of operation, 2-17
 timing for external gate
 external CONVERT (figure), 2-110
 internal CONVERT (figure), 2-109
 frequency output specifications, A-2
 Frequency_Shift_Keying function, 4-32
 frequency shifting keying (FSK)
 description, 4-14 to 4-15
 programming, 4-31 to 4-32
 FSC_SRC signal (table), 2-115
 FSCLK signal
 analog input timing/control (table), 2-114
 analog output timing/control
 (table), 3-111
 FSK. *See* frequency shifting keying (FSK).
 FTP support, E-1

G

G_GATE signal
 buffered cumulative event counting, 4-5
 buffered noncumulative event counting,
 4-4 to 4-5
 buffered period measurement, 4-7 to 4-8
 buffered pulse-train generation, 4-14
 buffered pulsewidth measurement, 4-9
 buffered retriggerable single pulse
 generation, 4-11 to 4-12
 buffered semiperiod measurement, 4-8
 buffered static pulse-train
 generation, 4-13
 continuous pulse-train generation
 (figure), 4-13
 frequency shift keying (FSK),
 4-14 to 4-15
 minimum pulsewidth, 4-56
 pulse generation for ETS, 4-15
 retriggerable single pulse
 generation, 4-11
 simple gated-event counting, 4-4
 simplified general-purpose counter/timer
 model, 4-2 to 4-3
 single triggered pulse generation, 4-10
 single-period measurement, 4-6 to 4-7
 single-pulsewidth measurement, 4-7
 G_OUT signal
 buffered pulse-train generation
 (figure), 4-14
 buffered retriggerable single pulse
 generation (figure), 4-12
 buffered static pulse-train generation
 (figure), 4-13
 continuous pulse-train generation
 (figure), 4-13
 frequency shift keying (figure), 4-15
 pulse generation for ETS (figure), 4-15
 retriggerable single pulse
 generation, 4-11
 simplified general-purpose counter/timer
 model, 4-3
 single pulse generation, 4-10
 single triggered pulse generation, 4-10
 G_OUT0/RTSI_IO signal (table), 4-16
 G_OUT1/DIV_TC_OUT signal (table), 4-16
 G_Source_Divide_By_2 bit, 4-52
 G_SOURCE signal
 buffered cumulative event counting, 4-5
 buffered noncumulative event
 counting, 4-5
 buffered period measurement, 4-7 to 4-8
 buffered pulse-train generation, 4-14
 buffered pulsewidth measurement, 4-9
 buffered retriggerable single pulse
 generation, 4-11 to 4-12
 buffered semiperiod measurement, 4-8
 buffered static pulse-train
 generation, 4-13
 continuous pulse-train generation,
 4-12 to 4-13
 relative position sensing, 4-6

- retriggerable single pulse
 - generation, 4-11
- simple event counting, 4-4
- simple gated-event counting, 4-4
- simplified general-purpose counter/timer
 - model, 4-2 to 4-3
- single pulse generation, 4-9 to 4-10
- single triggered pulse generation, 4-10
- single-period measurement, 4-6 to 4-7
- single-pulsewidth measurement, 4-7
- G_UP_DOWN<0..1> signal
 - description (table), 4-16
 - relative position sensing, 4-6
- gating
 - free-run gating mode
 - external gate timing, external CONVERT (figure), 2-110
 - external gate timing, internal CONVERT (figure), 2-109
 - theory of operation, 2-17
 - halt-gating mode
 - external gate timing, internal CONVERT (figure), 2-111
 - theory of operation, 2-17 to 2-18
 - hardware gate programming
 - analog input timing/control, 2-30 to 2-31
 - secondary analog output operation, 3-39
 - overview, 2-16, 2-109
 - software gate operation
 - analog input timing/control, 2-31
 - secondary analog output operation, 3-40
- general-purpose counter/timer, 4-1 to 4-56
 - counter/timer functions, 4-3 to 4-15
 - event counting, 4-3 to 4-6
 - pulse generation, 4-9 to 4-12
 - pulse-train generation, 4-12 to 4-15
 - time measurement, 4-6 to 4-9
 - features, 4-1 to 4-2
 - overview, 4-1
 - pin interface (table), 4-16
 - programming information, 4-17 to 4-52
 - arming, 4-18
 - bitfield descriptions, 4-35 to 4-52
 - buffered event counting, 4-20 to 4-22
 - buffered period, semiperiod, and pulsewidth measurement, 4-26 to 4-28
 - enabling general-purpose counter/timer output pin, 4-35
 - frequency shift keying, 4-31 to 4-32
 - notation, 4-18
 - overview, 4-17
 - pulse and continuous pulse-train generation, 4-28 to 4-31
 - pulse-train generation for ETS, 4-33 to 4-34
 - reading counter contents, 4-34
 - reading hardware save registers, 4-34 to 4-35
 - relative position sensing, 4-23 to 4-24
 - resetting, 4-18
 - simple event counting, 4-19 to 4-20
 - single-period and pulsewidth measurement, 4-24 to 4-25
 - simplified model, 4-2 to 4-3
 - specifications, A-1
 - timing diagrams, 4-53 to 4-56
 - CTRGATE reference pin selection (table), 4-54
 - CTRSRC minimum period and minimum pulsewidth (figure), 4-55
 - CTRSRC reference pin selection (table), 4-53
 - CTRSRC to CTROUT delay, 4-55 to 4-56
 - CTR_U/D reference pin selection (table), 4-54
 - G_GATE minimum pulsewidth, 4-56

Generic_Status bit, 7-15
 GHOST signal
 description (table), 2-21
 simplified analog input model, 2-6
 Gi_Analog_Trigger_Reset bit, 4-35
 Gi_Arm_All function, 4-18
 Gi_Arm bit, 4-36
 Gi_Arm_Copy bit, 4-36
 Gi_Armed_St bit, 4-36
 Gi_Autoincrement bit, 4-36
 Gi_Bank_St bit, 4-36
 Gi_Bank_Switch_Enable bit, 4-37
 Gi_Bank_Switch_Mode bit, 4-37
 Gi_Bank_Switch_Start bit, 4-37
 Gi_Buffered_Event_Counting function,
 4-21 to 4-22
 Gi_Counting_Once bit, 4-37
 Gi_Counting_St bit, 4-38
 Gi_Disarm bit, 4-38
 Gi_Disarm_Copy bit, 4-38
 Gi_Gate_Error_Confirm bit, 4-38
 Gi_Gate_Error_St bit, 4-38
 Gi_Gate_Interrupt_Act bit, 4-39
 Gi_Gate_Interrupt_Enable bit, 4-39
 Gi_Gate_Interrupt_St bit, 4-39
 Gi_Gate_On_Both_Edges bit, 4-39
 Gi_Gate_Polarity bit, 4-40
 Gi_Gate_Second_Irq_Enable bit, 4-40
 Gi_Gate_Select bit, 4-40
 Gi_Gate_Select_Load_Source bit, 4-41
 Gi_Gate_St bit, 4-41
 Gi_Gating_Mode bit, 4-41
 Gi_HW_Save_St bit, 4-42
 Gi_HW_Save_Value bit, 4-42
 Gi_Little_Big_Endian bit, 4-42
 Gi_Load_A bit, 4-43
 Gi_Load_B bit, 4-43
 Gi_Load bit, 4-42
 Gi_Load_Source_Select bit, 4-43
 Gi_Loading_On_Gate bit, 4-44
 Gi_Loading_On_TC bit, 4-44
 Gi_Next_Load_Source_St bit, 4-44
 Gi_No_Load_Between_Gates_St bit, 4-44
 Gi_OR_Gate bit, 4-45
 Gi_Output_Mode bit, 4-45
 Gi_Output_Polarity bit, 4-45
 Gi_Output_St bit, 4-45
 Gi_Permanent_State_Data_St bit, 4-46
 Gi_Read_Acknowledges_Irq bit, 4-46
 Gi_Reload_Source_Switching bit, 4-46
 Gi_Reset bit, 4-46
 Gi_Save_Copy bit, 4-47
 Gi_Save_St bit, 4-47
 Gi_Save_Trace bit, 4-47
 Gi_Save_Value bit, 4-47
 Gi_Seamless_Pulse_Train_Change
 function, 4-31
 Gi_Simple_Event_Counting function,
 4-19 to 4-20
 Gi_Source_Polarity bit, 4-48
 Gi_Source_Select bit, 4-48
 Gi_Stale_Data_St bit, 4-48
 Gi_Stop_Mode bit, 4-48
 Gi_Synchronized_Gate bit, 4-49
 Gi_TC_Error_Confirm bit, 4-49
 Gi_TC_Error_St bit, 4-49
 Gi_TC_Interrupt_Ack bit, 4-49
 Gi_TC_Interrupt_Enable bit, 4-50
 Gi_TC_Second_Irq_Enable bit, 4-50
 Gi_TC_St bit, 4-50
 Gi_Trigger_Mode_For_Edge_Gate bit, 4-50
 Gi_Up_Down bit, 4-51
 Gi_Watch function, 4-34
 Gi_Write_Acknowledges_Irq bit, 4-51
 Gi_Write_Switch bit, 4-51
 GPCT. *See* general-purpose counter/timer.
 GPFO_0_Output_Enable bit, 4-51
 GPFO_0_Output_Select bit, 4-52
 GPFO_1_Output_Enable bit, 4-52
 GPFO_1_Output_Select bit, 4-52

H

- halt-gating mode
 - external gate timing, internal CONVERT (figure), 2-111
 - theory of operation, 2-17 to 2-18
- hardware gate programming
 - analog input timing/control, 2-30 to 2-31
 - secondary analog output operation, 3-39
- hardware save registers, reading, 4-34 to 4-35
- hardware-controlled serial digital I/O, 7-10 to 7-12

I

- IN_TIMEBASE signal
 - clock distribution (figure), 2-13
 - external START mode, 2-13
 - timebases derived from (table), 10-2 to 10-3
- IN_TIMEBASE2 signal
 - analog input timing/control (table), 2-115
 - analog output timing/control (table), 3-111
- initialization, power-up. *See* board power-up initialization.
- initializing configuration memory output, 2-28 to 2-29
- INT_SCLK_SEL signal (table), 3-111
- Intel bus. *See* bus interface module.
- INTEL/MOTO* signal (table), 9-2
- internal CONVERT mode
 - CONVERT timing, 2-9 to 2-10
 - free-run gating mode timing, internal CONVERT (figure), 2-109
 - halt-gating mode timing, internal CONVERT (figure), 2-111
 - START and SCAN_IN_PROG trigger output, 2-101
 - START trigger output, 2-101
 - START1 and START2 triggers in synchronous mode, 2-97 to 2-98
- internal START mode, scan-level timing and control, 2-11 to 2-12
- internal UPDATE
 - external trigger timing
 - synchronous edge (figure), 3-103
 - synchronous level (figure), 3-103
 - primary analog output, 3-11 to 3-12
 - trigger output, START1 delays, synchronous mode (figure), 3-105
- Interrupt_A_Enable bit, 8-12
- Interrupt_A_Output_Select bit, 8-12
- Interrupt_A_St bit, 8-13
- Interrupt_B_Enable bit, 8-13
- Interrupt_B_Output_Select bit, 8-13
- Interrupt_B_St bit, 8-13
- interrupt control, 8-1 to 8-16
 - analog input interrupt control, 2-130 to 2-131
 - description, 2-130
 - interrupts and their causes (table), 2-131
 - analog output interrupt control, 3-122
 - bitfield descriptions, 8-12 to 8-14
 - features, 8-1
 - interrupt condition summary (table), 8-15 to 8-16
 - interrupt handling, programming, 8-5 to 8-12
 - Interrupt Group A, 8-6 to 8-9
 - Interrupt Group B, 8-9 to 8-12
 - interrupt program, 8-6
 - interrupt interface, programming, 8-3 to 8-5
 - interrupt output polarity, 8-3
 - interrupt output select and enable, 8-3 to 8-4
 - pass-through interrupt, 8-4 to 8-5
 - overview, 8-1
 - pin interface (table), 8-2
- interrupt latency, 3-32, 3-42
- Interrupt_Output_On_3_Pins bit, 8-13

Interrupt_Output_Polarity bit, 8-13

interrupts

- enabling
 - analog input timing/control, 2-40 to 2-41
 - primary analog output operation, 3-30
- programming
 - analog input-related interrupts, 2-46 to 2-48
 - primary analog output, 3-35 to 3-37
 - secondary analog output, 3-45
- servicing, for waveform staging, 3-32, 3-42

interval scanning mode timing, 2-106 to 2-108

- clock periods (table), 2-107
- signals for (figure), 2-106

IRQ_IN<0..1> signal (table), 8-2

IRQ_OUT<0..7> signal (table), 8-2

L

LDAC*<0..1> signals

- DAC interface, 3-8
- decoded signal timing, 3-94 to 3-95
- description (table), 3-18
- setting source and update mode, primary analog output operation, 3-29
- simplified analog output model, 3-5

local buffer mode

- FIFO data interface, 3-9 to 3-10
- timing, 3-96 to 3-97

LOCALMUX_CLK* signal

- configuration FIFO control and external multiplexer control, 2-8
- configuration memory timing, 2-89 to 2-91
- description (table), 2-22
- maximum rate analog input, 2-91 to 2-92
- nominal pulsewidths (table), 2-133
- simplified analog input model, 2-5

LOCALMUX_FFRT* signal

- configuration FIFO, 2-8
- configuration memory timing, 2-89 to 2-91
- description (table), 2-22
- maximum rate analog input, 2-91 to 2-92
- nominal pulsewidths (table), 2-133
- simplified analog input model, 2-5

low-level timing and control functions, 2-6 to 2-11

- ADC control, 2-7
- configuration FIFO and external multiplexer control, 2-7 to 2-9
- CONVERT timing, 2-9 to 2-11
- Data FIFO control, 2-7

M

macro-level analog input timing, 2-106 to 2-108

manual. *See* documentation.

master/slave operation

- analog input programming, 2-45 to 2-46
- analog output programming
 - master/slave operation considerations, 3-35
 - secondary analog output, 3-45

master/slave trigger

- analog input timing/control module, 2-16
- analog output timing/control module, 3-15 to 3-16

maximum rate analog input, 2-91 to 2-92

maximum update rate timing, 3-101 to 3-102

Misc_Counter_TCs_Output_Enable bit, 10-14

miscellaneous functions, 10-1 to 10-15

- analog trigger, 10-3 to 10-6
 - high-hysteresis mode (figure), 10-5
 - high-window mode (figure), 10-4
 - low-hysteresis mode (figure), 10-6
 - low-window mode (figure), 10-4
 - middle-window mode (figure), 10-5

- clock distribution, 10-2 to 10-3
 - master/slave distribution across RTSI bus (figure), 10-2
 - timebases derived from IN_TIMEBASE (table), 10-2 to 10-3
- features, 10-1
- frequency output, 10-3
- overview, 10-1
- pin interface, 10-9 to 10-10
- programming information, 10-10 to 10-15
 - analog trigger, 10-12
 - bitfield descriptions, 10-12 to 10-15
 - clock distribution, 10-10 to 10-11
 - FOUT, 10-12
- test mode, 10-6 to 10-9
 - checking input pin connectivity, 10-7
 - input pin pairs (table), 10-8 to 10-9
 - internal gate tree structure (figure), 10-7
 - testing RESET pin, 10-8
- Motorola bus. *See* bus interface module.
- MSC_Clock_Configure function, 10-11
- MSC_FOUT_Configure function, 10-12
- MSC_Generic_Control function, 7-12
- MSC_Generic_Status function, 7-13
- MSC_IRQ_Configure function, 8-3 to 8-4
- MSC_IRQ_Personality function, 8-3
- MSC_Pass_Through_Interrupt function, 8-4 to 8-5
- MSC_Pass_Through_Second_Irq function, 8-5
- MSC_Write_Strobe function, 9-4
- MSC_IO_Pin_Configure function, 5-5 to 5-6
- MSC_RTSI_Pin_Configure function, 6-3
- multiplexer control, external, 2-7 to 2-9
- mute buffers, 3-15

- MUXFEF signal
 - configuration FIFO, 2-8
 - configuration memory timing, 2-89 to 2-91
 - description (table), 2-22

N

- nominal signal pulsewidths
 - analog input timing/control module (table), 2-133
 - analog output timing/control module (table), 3-1124
- number of scans, analog input programming, 2-32 to 2-33

O

- OSC signal (table), 10-10
- OUT_CLK signal
 - analog input timing/control module
 - basic analog input timing, 2-86 to 2-87
 - description, 2-85
 - analog output timing/control module, 3-86
- OUTBRD_OSC signal (table), 10-10
- output control, analog output timing/control module, 3-123 to 3-124
- output pin for general-purpose counter/timer, enabling, 4-35
- OVER_DETECT signal, 2-86 to 2-87
- overrun error
 - analog input timing/control module, 2-132
 - analog output timing/control module, 3-122

P

- parallel mode, digital I/O, 7-2 to 7-3
 - parallel input, 7-3
 - parallel output, 7-3
 - programming, 7-9
- Pass_Thru_i_Interrupt_Enable bit, 8-14
- Pass_Thru_i_Interrupt_Polarity bit, 8-14
- Pass_Thru_i_Interrupt_St bit, 8-14
- Pass_Thru_i_Second_Irq_Enable bit, 8-14
- pass-through interrupt, 8-4 to 8-5
- Period_And_Semi_Period_And_Pulse_Width_Measurement_ISR function, 4-27 to 4-28
- period measurement
 - buffered period measurement, 4-7 to 4-8
 - buffered semiperiod measurement, 4-8
 - CTRSRC minimum period and minimum pulsewidth (figure), 4-55
 - programming
 - buffered period, semiperiod, and pulsewidth measurement, 4-26 to 4-28
 - single-period measurement, 4-24 to 4-25
- PFI module, 5-1 to 5-9
 - bitfield descriptions, 5-6 to 5-7
 - features, 5-1
 - overview, 5-1
 - PFI<0..9> input selections (table), 5-7 to 5-8
 - PFI<0..9> output selections (table), 5-8 to 5-9
 - pin interface (table), 5-2 to 5-5
 - programming information, 5-5 to 5-6
 - simplified analog input model, 2-5
- PFI selectors for trigger signals (table)
 - analog input trigger selection, 2-121
 - analog output trigger selection, 3-115 to 3-116
- PFI signals
 - CTRGATE reference pin selection (table), 4-54
 - CTRSRC reference pin selection (table), 4-53
 - external trigger timing, 3-102
 - external UPDATE mode, 3-12
 - master/slave trigger, 3-15
 - SCAN_IN_PROG deassertion, 2-103
 - simplified analog input model, 2-5
 - simplified analog output model, 3-4
 - START trigger and SCAN_IN_PROG assertion, 2-100
 - external CONVERT mode, 2-102
 - internal CONVERT mode, 2-101
 - START1 and START2 triggers
 - asynchronous mode, 2-99 to 2-100
 - synchronous mode, 2-97 to 2-98
 - START1 trigger output, 3-104 to 3-107
- PFI0/AI_START1 signal (table), 5-2
- PFI0/AI_START2 signal (table), 5-2
- PFI2/CONV* signal (table), 5-3
- PFI3/G_SRC1 signal (table), 5-3
- PFI4/G_GATE1 signal (table), 5-3
- PFI5/UPDATE* signal (table), 5-3
- PFI6/AO_START1 signal (table), 5-4
- PFI7/AI_START signal (table), 5-4
- PFI8/G_SRC0 signal (table), 5-5
- PFI9/G_GATE0 signal (table), 5-5
- pin capacitance specifications, A-2
- pin interface. *See also* signals.
 - alphabetical list of pins (table), C-1 to C-7
 - analog input timing/control module (table), 2-19 to 2-23
 - analog output timing/control module (table), 3-16 to 3-20
 - bus interface module (table), 9-1 to 9-3
 - digital I/O (table), 7-6 to 7-7
 - general-purpose counter/timer (table), 4-16
 - interrupt control (table), 8-2
 - miscellaneous functions (table), 10-9 to 10-10
 - PFI module (table), 5-2 to 5-5

- RTSI trigger module (table), 6-1 to 6-2
- summary of buffer types (table), C-7 to C-8
- posttrigger acquisition mode, 2-14
- power-up initialization. *See* board power-up initialization.
- pretrigger acquisition mode, 2-14 to 2-15
- primary analog output operation,
 - programming, 3-20 to 3-32
 - arming, 3-30 to 3-31
 - board power-up initialization, 3-22 to 3-23
 - channel select, 3-28
 - enable interrupts, 3-30
 - FIFO mode, 3-29 to 3-30
 - LDAC source and UPDATE mode, 3-29
 - number of buffers, 3-24 to 3-26
 - overview, 3-21
 - resetting, 3-21 to 3-22
 - sequence of functions, 3-31 to 3-32
 - starting the waveform, 3-30 to 3-31
 - stop on error, 3-29
 - trigger signals, 3-23 to 3-24
 - update selection, 3-26 to 3-28
- primary group analog output modes, 3-5 to 3-7. *See also* analog output functions.
 - CPU-driven analog output, 3-6 to 3-7
 - DAQ-STC and CPU conflict, 3-7
 - DAQ-STC-driven analog output, 3-6
- programmable function inputs. *See* PFI module.
- programming. *See also* bitfield descriptions.
 - analog input timing/control module, 2-24 to 2-83
 - arming, 2-41
 - bitfield descriptions, 2-48 to 2-83
 - board environment setup, 2-29 to 2-30
 - board power-up initialization, 2-27 to 2-28
 - changing scan rate during acquisition, 2-43 to 2-44
 - convert signal, 2-38 to 2-40
 - enable interrupts, 2-40 to 2-41
 - end of scan, 2-37 to 2-38
 - FIFO request, 2-30
 - hardware gate programming, 2-30 to 2-31
 - initialize configuration memory output, 2-28 to 2-29
 - interrupts, 2-46 to 2-48
 - master/slave operation considerations, 2-45 to 2-46
 - number of scans, 2-33
 - overview, 2-25 to 2-26
 - register and bitfield considerations, 2-24
 - resetting, 2-26 to 2-27
 - sequence of functions for, 2-42
 - single scan, 2-42 to 2-43
 - software gate operation, 2-31
 - staged acquisition, 2-44 to 2-45
 - start of scan, 2-34 to 2-37
 - starting the acquisition, 2-41 to 2-42
 - trigger signals, 2-32 to 2-33
 - windowing registers, 2-25
 - analog output operation, primary, 3-20 to 3-32
 - arming, 3-30 to 3-31
 - bitfield descriptions, 3-45 to 3-84
 - board power-up initialization, 3-22 to 3-23
 - changing update rate, 3-34 to 3-35
 - channel select, 3-28
 - enable interrupts, 3-30
 - FIFO mode, 3-29 to 3-30
 - interrupts, 3-35 to 3-37
 - LDAC source and UPDATE mode, 3-29
 - master/slave operation considerations, 3-35

- number of buffers, 3-24 to 3-26
- overview, 3-21
- resetting, 3-21 to 3-22
- sequence of functions in, 3-31 to 3-32
- starting the waveform, 3-30 to 3-31
- stop on error, 3-29
- trigger signals, 3-23 to 3-24
- update selection, 3-26 to 3-28
- waveform staging, 3-32 to 3-34
- analog output operation, secondary, 3-38 to 3-42
 - arming, 3-41
 - bitfield descriptions, 3-45 to 3-84
 - board power-up initialization, 3-39
 - changing update rate, 3-44 to 3-45
 - counting for waveform staging, 3-40
 - hardware gate programming, 3-39
 - interrupts, 3-45
 - master/slave operation
 - considerations, 3-45
 - overview, 3-38
 - resetting, 3-38
 - software gate operation, 3-40
 - update selection, 3-40 to 3-41
 - waveform staging, 3-42 to 3-44
- bus interface module, 9-3 to 9-5
 - bitfield descriptions, 9-4 to 9-5
 - write strobes, 9-4
- digital I/O, 7-7 to 7-15
 - bitfield descriptions, 7-13 to 7-15
 - control lines, 7-12
 - hardware-controlled serial digital I/O, 7-10 to 7-12
 - parallel digital I/O, 7-9
 - programming the digital interface, 7-8 to 7-9
 - reading status lines, 7-13
 - software-controlled serial digital I/O, 7-12
 - windowed mode register access
 - example, 7-7 to 7-8
- general-purpose counter/timer, 4-17 to 4-52
 - arming, 4-18
 - bitfield descriptions, 4-35 to 4-52
 - buffered event counting, 4-20 to 4-22
 - buffered period, semiperiod, and pulsewidth measurement, 4-26 to 4-28
 - enabling general-purpose counter/timer output pin, 4-35
 - frequency shift keying, 4-31 to 4-32
 - notation, 4-18
 - overview, 4-17
 - pulse and continuous pulse-train generation, 4-28 to 4-31
 - pulse-train generation for ETS, 4-33 to 4-34
 - reading counter contents, 4-34
 - reading hardware save registers, 4-34 to 4-35
 - relative position sensing, 4-23 to 4-24
 - resetting, 4-18
 - simple event counting, 4-19 to 4-20
 - single-period and pulsewidth measurement, 4-24 to 4-25
- interrupt handling, 8-5 to 8-12
 - Interrupt Group A, 8-6 to 8-9
 - Interrupt Group B, 8-9 to 8-12
 - interrupt program, 8-6
- interrupt interface, 8-3 to 8-5
 - interrupt output polarity, 8-3
 - interrupt output select and enable, 8-3 to 8-4
 - pass-through interrupt, 8-4 to 8-5
- miscellaneous functions, 10-10 to 10-15
 - analog trigger, 10-12
 - bitfield descriptions, 10-12 to 10-15
 - clock distribution, 10-10 to 10-11
 - FOUT, 10-12
 - PFI module, 5-5 to 5-6
- pulse generation for ETS, 4-15

pulse generation functions, 4-9 to 4-12
 buffered retriggerable single pulse generation, 4-11 to 4-12
 programming, 4-28 to 4-31
 retriggerable single pulse generation, 4-11
 single pulse generation, 4-9 to 4-10
 single triggered pulse generation, 4-10

Pulse_Train_Generation_For_ETS function, 4-33 to 4-34

pulse-train generation functions, 4-12 to 4-15
 buffered pulse-train generation, 4-14
 buffered static pulse-train generation, 4-13
 continuous pulse-train generation, 4-12 to 4-13
 frequency shifting keying (FSK), 4-14 to 4-15
 programming
 frequency shifting keying, 4-31 to 4-32
 pulse and continuous pulse-train generation, 4-28 to 4-31
 pulse generation for ETS, 4-33 to 4-34
 pulse generation for ETS, 4-15

pulsewidth measurement
 buffered pulsewidth measurement, 4-9
 CTRSRC minimum period and minimum pulsewidth (figure), 4-55
 G_GATE minimum pulsewidth, 4-56
 programming
 buffered period, semiperiod, and pulsewidth measurement, 4-26 to 4-28
 single-period measurement, 4-24 to 4-25
 single-pulsewidth measurement, 4-7

pulsewidths, nominal
 analog input timing/control module (table), 2-133

analog output timing/control module (table), 3-124

R

RD/WR* signal (table), 9-3

Read_Gi_HW_Save_Registers function, 4-35

reading
 counter contents, 4-34
 hardware save registers, 4-34 to 4-35
 status lines, digital I/O, 7-13

recommended operating conditions, A-2 to A-3

registers, B-1 to B-38
 address order (table), B-5 to B-8
 alphabetical list (table), B-1 to B-4
 bitfield location guide (table), B-9
 programming considerations, 2-24
 register maps, B-10 to B-38

relative position sensing
 description, 4-6
 programming, 4-23 to 4-24

Relative_Position_Sensing function, 4-23 to 4-24

Reserved_One bit, 10-14

RESET* signal
 description (table), 9-3
 testing, 10-8

resetting operation
 analog input timing/control module, 2-26 to 2-27
 analog output timing/control module
 primary analog output operation, 3-21 to 3-22
 secondary analog output operation, 3-38
 general-purpose counter/timer module, 4-18

retriggerable single pulse generation, 4-11

revision history for DAQ-STC, D-1 to D-2

RTSI_Board_i_Output_Select bit, 6-4

RTSI_Board_i_Pin_Dir bit, 6-4
 RTSI_BRD<0..3> signals (table), 6-2
 RTSI_Clock_Mode bit, 6-4
 RTSI_OSC signal (table), 6-2
 RTSI_Sub_Selection_1 bit, 6-5
 RTSI_Trig_i_Output_Select bit, 6-5
 RTSI_Trig_i_Pin_Dir bit, 6-5
 RTSI_TRIGGER<0..6> signals (table), 6-2
 RTSI signals

- CTR_GATE reference pin selection (table), 4-54
- CTRSRC reference pin selection, 4-53
- external trigger timing, 3-102
- external UPDATE mode, 3-12
- master/slave trigger, 3-15
- SCAN_IN_PROG deassertion, 2-103
- simplified analog input model, 2-5
- simplified analog output model, 3-4
- START trigger and SCAN_IN_PROG assertion, 2-100
 - external CONVERT mode, 2-102
 - internal CONVERT mode, 2-101
- START1 and START2 triggers, 2-97
 - asynchronous mode, 2-99 to 2-100
 - synchronous mode, 2-98 to 2-99
- START1 trigger output, 3-104 to 3-107
- STOP trigger, 2-103
 - asynchronous mode, 2-104
 - synchronous mode, 2-104

RTSI trigger module, 6-1 to 6-7

- features, 6-1
- overview, 6-1
- pin interface, 6-1 to 6-2
- programming information, 6-2 to 6-5
 - bitfield descriptions, 6-3 to 6-5
 - MSC_RTSI_Pin_Configure function, 6-3
 - RTSI_BRD<0..1> output selections (table), 6-7
 - RTSI_BRD<2..3> output selections (table), 6-7

RTSI_TRIGGER<0..6> output selections (table), 6-6

S

SC counter

- control circuitry, 2-123 to 2-125
- description, 2-123

SC_CE signal

- description (table), 2-115
- SC counter operation, 2-125

SC_CLK signal (table), 2-115

SC_DISARM signal, 2-125

SC_GATE signal (table), 2-115

SC_HOLD signal (table), 2-115

SC_LOAD signal

- description (table), 2-116
- SC counter operation, 2-125

SC_LOAD_SRC signal (table), 2-116

SC_SRC signal (table), 2-116

SC_START1 signal (table), 2-116

SC_TC signal

- continuous acquisition mode, 2-15
- counter outputs (figure), 2-105
- description (table), 2-116
- nominal pulsewidths (table), 2-133
- pin interface (table), 2-23
- posttrigger acquisition mode, 2-14
- staged acquisition, 2-16

scan functions

- AI_Number_Of_Scans, 2-33 to 2-34
- AI_Scan_End, 2-37 to 2-38
- AI_Scan_Rate_Change, 2-43 to 2-44
- AI_Scan_Start, 2-34 to 2-37, 2-42 to 2-43

SCAN_IN_PROG signal

- assertion, analog input trigger output, 2-100 to 2-102
 - external CONVERT mode, 2-102
 - internal CONVERT mode, 2-101
- deassertion, analog input trigger output, 2-103

- description (table), 2-23
- external CONVERT mode, 2-10 to 2-11
- external gating, 2-111
- internal CONVERT mode, 2-10
- nominal pulsewidths (table), 2-133
- simplified analog input model, 2-6
- scan-level timing and control functions, 2-11 to 2-13
 - external START mode, 2-12 to 2-13
 - internal START mode, 2-11 to 2-12
- SCKG signal
 - description (table), 2-115, 3-112
 - DIV counter operation, 2-129
 - SC counter operation, 2-124
- SCLK signal
 - analog input timing/control module (table), 2-115
 - analog output timing/control module (table), 3-112
- SCLKG signal (table), 2-116
- SEC_IRQ_OUT_BANK0 signal (table)
- SEC_IRQ_OUT_BANK1 signal (table)
- secondary analog output operation
 - overview, 3-16
 - programming, 3-38 to 3-42
 - arming, 3-41
 - board power-up initialization, 3-39
 - counting for waveform staging, 3-40
 - hardware gate programming, 3-39
 - overview, 3-38
 - resetting, 3-38
 - software gate operation, 3-40
 - update selection, 3-40 to 3-41
 - timing, 3-93
- Serial_DIO function, 7-11
- serial input timing, digital I/O, 7-15 to 7-16
- serial link data interface, 3-10
- serial mode, digital I/O, 7-4 to 7-5
 - hardware-controlled serial digital I/O, 7-10 to 7-12
 - serial input, 7-4
 - serial I/O, 7-5
 - serial output, 7-4 to 7-5
 - serial output timing (figure), 7-16
- Service_Group_A function, 8-6 to 8-9
- Service_Group_B function, 8-9 to 8-12
- Shared_Level_Service function, 8-6
- SHIFTIN* signal
 - ADC control, 2-7
 - basic analog input timing, 2-86 to 2-87
 - data FIFO control, 2-7
 - data FIFO timing, 2-88
 - description (table), 2-23
 - nominal pulsewidths (table), 2-133
 - simplified analog input model, 2-5
- SI counter
 - control circuitry, 2-126 to 2-127
 - description, 2-126
- SI_CE signal
 - description (table), 2-117
 - SI counter operation, 2-126
- SI_CLK signal (table), 2-117
- SI_DISARM signal, 2-126
- SI_HOLD signal (table), 2-117
- SI_LOAD signal
 - description (table), 2-117
 - SI counter operation, 2-126
- SI_LOAD_SRC signal (table), 2-117
- SI_SRC signal (table), 2-117
- SI_START1 signal (table), 2-117
- SI_TC signal
 - counter outputs (figure), 2-105
 - description (table), 2-118
 - external START mode, 2-13
 - internal START mode, 2-11
 - pin interface description (table), 2-23
- SI2 counter
 - control circuitry, 2-127 to 2-128
 - description, 2-127

- SI2_CE signal
 - description (table), 2-116
 - SI2 counter operation, 2-128
- SI2_CLK signal (table), 2-116
- SI2_DISARM signal, 2-128
- SI2_LOAD signal
 - description (table), 2-116
 - SI2 counter operation, 2-128
- SI2_LOAD_SRC signal (table), 2-117
- SI2_SRC signal (table), 2-117
- SI2_TC signal
 - description (table), 2-117
 - DIV counter operation, 2-129
- signals. *See also* pin interface; specific signal names.
 - alphabetical list of pins (table), C-1 to C-7
 - analog input timing/control module
 - internal signals and operation (table), 2-113 to 2-119
 - signal definitions for timing, 2-84 to 2-85
 - trigger selection and conditioning, 2-122 to 2-123
 - trigger signal programming information, 2-32 to 2-33
 - analog output timing/control module
 - internal signals and operation (table), 3-109 to 3-114
 - signal definitions for timing, 3-84 to 3-86
 - trigger selection and conditioning, 3-116
 - trigger signal programming information, 3-23 to 3-24
 - summary of buffer types (table), C-7 to C-8
- simple event counting
 - description, 4-4
 - programming, 4-19 to 4-20
- simple gated-event counting, 4-4
- Single_Period_And_Pulse_Width_Measurement function, 4-24 to 4-25
- single pulse generation, 4-9 to 4-10
- Single_Pulse_Generation function, 4-29 to 4-30
- single scan, analog input programming, 2-42 to 2-43
- single triggered pulse generation, 4-10
- single-buffer mode, primary analog output, 3-13
- single-period measurement, 4-6 to 4-7
- single-pulsewidth measurement, 4-7
- single-wire mode, 2-18
- Slow_Internal_Time_Divide_By_2 bit, 10-14
- Slow_Internal_Timebase bit, 10-15
- SOC signal
 - ADC control, 2-7
 - basic analog input timing, 2-86 to 2-87
 - description (table), 2-23
 - simplified analog input model, 2-5
- software gate operation
 - analog input programming, 2-31
 - secondary analog output operation, 3-40
- software-controlled serial digital I/O, 7-12
- specifications, A-1 to A-4
 - absolute maximum ratings, A-2
 - analog input, A-1
 - analog output, A-1
 - DC characteristics, A-3 to A-4
 - digital I/O, A-1
 - frequency output, A-2
 - general-purpose counter/timers, A-1
 - pin capacitance, A-2
 - recommended operating conditions, A-2 to A-3
- ST_TC error, 2-132
- staged acquisition
 - analog input programming, 2-44 to 2-45
 - description, 2-16
- start of scans, analog input programming, 2-34 to 2-37

- START signal
 - CONVERT timing
 - external CONVERT mode, 2-10 to 2-11
 - internal CONVERT mode, 2-9 to 2-10
 - description (table), 2-118
 - external trigger timing, 2-94 to 2-97
 - free-run gating mode, 2-17
 - gating, 2-16
 - halt-gating mode, 2-17 to 2-18
 - scan-level timing and control functions, 2-11 to 2-13
 - external START mode, 2-12 to 2-13
 - internal START mode, 2-11 to 2-12
 - simplified analog input model, 2-4
 - single-wire mode, 2-18
 - trigger output, 2-100 to 2-102
 - external CONVERT mode, 2-102
 - internal CONVERT mode, 2-101
 - trigger routing logic (figure), 2-120
- START1 signal, analog input timing/control module
 - continuous acquisition mode, 2-15
 - description (table), 2-118
 - external START mode, 2-12 to 2-13
 - external trigger timing, 2-94 to 2-96
 - internal START mode, 2-11
 - interval scanning mode, 2-106 to 2-108
 - master/slave trigger, 2-16
 - posttrigger acquisition mode, 2-14
 - simplified analog input model, 2-4, 2-6
 - staged acquisition, 2-16
 - trigger operation, 2-122
 - trigger output, 2-97 to 2-100
 - asynchronous mode, 2-99 to 2-100
 - synchronous mode, 2-97 to 2-99
 - trigger routing logic (figure), 2-120
- START1 signal, analog output timing/control module
 - continuous-mode, 3-14
 - description (table), 3-112
 - external trigger timing, 3-102 to 3-104
 - external UPDATE timing, 3-12
 - internal UPDATE timing, 3-11 to 3-12
 - routing logic (figure), 3-115
 - simplified analog output model, 3-5
 - single-buffer mode, 3-13
 - trigger output
 - asynchronous mode, 3-106 to 3-107
 - synchronous mode, 3-104 to 3-106
- START2 signal
 - description (table), 2-118
 - external trigger timing, 2-94 to 2-96
 - interval scanning mode, 2-106 to 2-108
 - master/slave trigger, 2-16
 - posttrigger acquisition mode, 2-14
 - pretrigger acquisition mode, 2-14 to 2-15
 - trigger operation, 2-122
 - trigger output, 2-97 to 2-100
 - asynchronous mode, 2-99 to 2-100
 - synchronous mode, 2-97 to 2-99
 - trigger routing logic (figure), 2-120
- status lines, reading, 7-13
- STATUS<0..3> signal (table), 7-6
- stop on error, primary analog output programming, 3-29
- STOP signal
 - analog input timing/control module (table), 2-119
 - analog output timing/control module (table), 3-112
 - external CONVERT mode, 2-10 to 2-11
 - external trigger timing, 2-94 to 2-97
 - internal CONVERT mode, 2-9 to 2-10
 - interval scanning mode, 2-106, 2-108
 - simplified analog input model, 2-4 to 2-6
 - trigger operation, 2-123
 - trigger output, 2-103 to 2-104
 - asynchronous mode (figure), 2-104
 - synchronous mode (figure), 2-104
 - trigger routing logic (figure), 2-120

STST_GATE signal
 description (table), 2-119
 external CONVERT mode, 2-10 to 2-11
 synchronization, trigger selection and conditioning
 analog input timing/control module, 2-122
 analog output timing/control module, 3-116

T

technical support, E-1 to E-2
 telephone and fax support numbers, E-2
 TEST_IN* signal (table), 10-10
 test mode, 10-6 to 10-9
 checking input pin connectivity, 10-7
 input pin pairs (table), 10-8 to 10-9
 internal gate tree structure (figure), 10-7
 testing RESET pin, 10-8
 TEST_OUT signal (table), 10-10
 time measurement functions, 4-6 to 4-9
 buffered period measurement, 4-7 to 4-8
 buffered pulsewidth measurement, 4-9
 buffered semiperiod measurement, 4-8
 single-period measurement, 4-6 to 4-7
 single-pulsewidth measurement, 4-7
 timebases derived from IN_TIMEBASE (table), 10-2 to 10-3
 timing diagrams
 analog input timing/control module, 2-84 to 2-111
 basic analog input timing, 2-86 to 2-87
 configuration memory, 2-89 to 2-91
 CONVERT_SRC signal, 2-84 to 2-85
 data FIFOs, 2-88
 external CONVERT source, 2-92 to 2-93
 external triggers, 2-93 to 2-97

maximum rate analog input, 2-91 to 2-92
 OUT_CLK signal, 2-85
 SCAN_IN_PROG deassertion, 2-103
 signal definitions, 2-84 to 2-85
 START trigger and SCAN_IN_PROG assertion, 2-100 to 2-103
 START1 and START2 triggers, 2-97 to 2-100
 STOP trigger, 2-103 to 2-104
 trigger output, 2-97 to 2-104
 analog output timing/control module, 3-84 to 3-108
 counter outputs, 3-107 to 3-108
 CPU-driven analog output timing, 3-88
 DAQ-STC- and CPU-driven analog output timing, 3-90 to 3-92
 DAQ-STC-driven analog output timing, 3-86 to 3-88
 decoded signal timing, 3-94 to 3-95
 external trigger timing, 3-102 to 3-104
 local buffer mode timing, 3-96 to 3-97
 maximum update rate timing, 3-101 to 3-102
 secondary analog output timing, 3-93
 signal definitions, 3-84 to 3-86
 trigger output, 3-104 to 3-107
 unbuffered data interface timing, 3-98 to 3-100
 bus interface module, 9-5 to 9-8
 Intel bus interface read timing (figure), 9-6
 Intel bus interface timing (table), 9-6 to 9-7
 Intel bus interface write timing (figure), 9-6
 Motorola bus interface read timing (figure), 9-7

- Motorola bus interface timing (table), 9-8
- Motorola bus interface write timing (figure), 9-8
- digital I/O, 7-15 to 7-16
 - serial input timing, 7-15 to 7-16
 - serial output timing, 7-16
- general-purpose counter/timer, 4-53 to 4-56
 - CTR_U/D reference pin selection (table), 4-54
 - CTRGATE reference pin selection (table), 4-54
 - CTRSRC minimum period and minimum pulsewidth (figure), 4-55
 - CTRSRC reference pin selection (table), 4-53
 - CTRSRC to CTROUT delay, 4-55 to 4-56
 - G_GATE minimum pulsewidth, 4-56
- TMRDACREQ signal
 - DAQ-STC-driven analog output timing, 3-86 to 3-87
 - description (table), 3-19
 - serial link data interface, 3-10
 - simplified analog output model, 3-5
- TMRDACWR* signal
 - DAC interface, 3-8
 - DAQ-STC- and CPU-driven analog output timing, 3-91 to 3-92
 - DAQ-STC-driven analog output, 3-6
 - DAQ-STC-driven analog output timing, 3-86 to 3-88
 - description (table), 3-19
 - FIFO data interface, 3-9
 - local buffer mode, 3-9 to 3-10
 - local buffer mode timing, 3-96 to 3-97
 - maximum update rate timing, 3-101
 - serial link data interface, 3-10
 - simplified analog output model, 3-4
 - unbuffered data interface, 3-11
 - unbuffered data interface timing, 3-98 to 3-100
- trigger, analog. *See* analog trigger circuit.
- trigger output, analog input timing/control, 2-97 to 2-102
 - SCAN_IN_PROG deassertion, 2-103
 - START trigger and SCAN_IN_PROG assertion, 2-100 to 2-102
 - external CONVERT mode, 2-102
 - internal CONVERT mode, 2-101
 - START1 and START2 triggers, 2-97 to 2-100
 - asynchronous mode, 2-99 to 2-100
 - synchronous mode, 2-97 to 2-99
 - STOP trigger, 2-103 to 2-104
 - asynchronous mode, 2-104
 - synchronous mode, 2-104
- trigger output, analog output timing/control module, 3-104 to 3-107
 - START1 trigger, asynchronous mode, 3-106 to 3-107
 - START1 trigger, synchronous mode, 3-104 to 3-106
- trigger selection and conditioning
 - analog input timing/control module, 2-119 to 2-122
 - edge detection, 2-122
 - EXT_GATE routing logic (figure), 2-121
 - PFI selectors (table), 2-121
 - START and STOP routing logic (figure), 2-120
 - START1 and START2 routing logic (figure), 2-120
 - synchronization, 2-122
 - trigger signals, 2-122 to 2-123
 - analog output timing/control module, 3-114 to 3-116
 - edge detection, 3-116

- EXT_GATE and EXT_GATE2
 - routing logic (figure), 3-115
- PFI selectors (table), 3-115 to 3-116
- START1 routing logic (figure), 3-115
- synchronization, 3-116
- trigger signals, 3-116
- trigger signals, programming
 - analog input timing/control module, 2-32 to 2-33
 - primary analog output timing/control module, 3-23 to 3-24
- triggers, external. *See* external trigger timing; external triggers.

U

- UC counter
 - control circuitry, 3-119
 - description, 3-118 to 3-119
- UC_CE signal (table), 3-112
- UC_CLK signal (table), 3-112
- UC_DISARM signal (table), 3-112
- UC_HOLD signal (table), 3-112
- UC_LOAD signal (table), 3-112
- UC_LOAD_SRC signal (table), 3-113
- UC_TC signal
 - continuous-mode, 3-13 to 3-14
 - description (table), 3-113
 - local buffer mode, 3-9 to 3-10
 - output timing (figure), 3-108
 - pin interface (table), 3-19
 - single-buffer mode, 3-13
- UI counter
 - control circuitry, 3-118
 - description, 3-117
 - internal UPDATE timing, 3-11 to 3-12
- UI_CE signal (table), 3-113
- UI_CLK signal (table), 3-113
- UI_DISARM signal (table), 3-113
- UI_LOAD signal (table), 3-113
- UI_LOAD_SRC signal (table), 3-113
- UI_SRC signal (table), 3-113
- UI_TC signal (table), 3-113
- UI2 counter
 - control circuitry, 3-121
 - description, 3-121
 - simplified analog output model, 3-5
- UI2_CE signal (table), 3-114
- UI2_CLK signal (table), 3-114
- UI2_LOAD signal (table), 3-114
- UI2_LOAD_SRC signal (table), 3-114
- UI2_SRC signal
 - description (table), 3-114
 - pin selection (table), 3-85 to 3-86
- UI2_TC error, 3-123
- UI2_TC signal (table), 3-114
- unbuffered data interface, 3-11
- unbuffered data interface timing, 3-98 to 3-100
- UPDATE modes. *See* external UPDATE; internal UPDATE.
- update rate, changing
 - primary analog output programming, 3-34 to 3-35
 - secondary analog output programming, 3-44 to 3-45
- update selection
 - primary analog output operation programming, 3-26 to 3-28
 - secondary analog output operation programming, 3-40 to 3-41
- UPDATE* signal
 - continuous-mode, 3-14
 - DAQ-STC-driven analog output, 3-6
 - DAQ-STC-driven analog output timing, 3-86 to 3-88
 - description (table), 3-20
 - external trigger timing, 3-102 to 3-104
 - external UPDATE timing, 3-12
 - FIFO data interface, 3-9
 - internal UPDATE timing, 3-11 to 3-12
 - local buffer mode timing, 3-96 to 3-97
 - maximum update rate timing, 3-101

- serial link data interface, 3-10
- simplified analog output model, 3-4 to 3-5
- single-buffer mode, 3-13
- unbuffered data interface, 3-11
- unbuffered data interface timing,
3-98 to 3-100
- UPDATE_SRC signal
 - external trigger timing, 3-102 to 3-104
 - pin selection (table), 3-85
- update timing for primary group, 3-11 to 3-12
 - external UPDATE, 3-12
 - internal UPDATE, 3-11 to 3-12
- UPDATE2* signal
 - description (table), 3-20
 - secondary analog output timing, 3-93
 - simplified analog output model, 3-5

W

- waveform, starting, primary analog output operation, 3-30 to 3-31
- waveform staging
 - buffer timing and control for primary analog output, 3-14 to 3-15
 - primary analog output, 3-32 to 3-34
 - secondary analog output, 3-42 to 3-44
 - counting, 3-40
- windowed mode register access
 - analog input programming considerations, 2-25
 - digital I/O programming example, 7-7 to 7-8
- WR/DS* signal (table), 9-3
- WRITE_STROBE<0..3> signal
 - description (table), 9-3
 - programming, 9-4