

## COMPREHENSIVE SERVICES

We offer competitive repair and calibration services, as well as easily accessible documentation and free downloadable resources.

## SELL YOUR SURPLUS

We buy new, used, decommissioned, and surplus parts from every NI series. We work out the best solution to suit your individual needs.

 Sell For Cash    Get Credit    Receive a Trade-In Deal

## OBSOLETE NI HARDWARE IN STOCK & READY TO SHIP

We stock **New**, **New Surplus**, **Refurbished**, and **Reconditioned** NI Hardware.



*Bridging the gap between the manufacturer and your legacy test system.*

 1-800-915-6216

 [www.apexwaves.com](http://www.apexwaves.com)

 [sales@apexwaves.com](mailto:sales@apexwaves.com)

*All trademarks, brands, and brand names are the property of their respective owners.*

**Request a Quote**

 **CLICK HERE**

**VXI-TB-1303**

# VXI-TB-1303 32-CHANNEL ISOTHERMAL TERMINAL BLOCK

This guide describes how to install and use the VXI-TB-1303 terminal block with a VXI-SC submodule.

## Introduction

---

The VXI-TB-1303 terminal block is a shielded board with screw terminals that connect to a VXI-SC submodule. The VXI-TB-1303 has a high-accuracy thermistor cold-junction temperature sensor, and an isothermal copper plane to minimize the temperature gradients across the screw terminals when you measure with thermocouples.

The terminal block has 80 screw terminals for easy connection. Thirty-two pairs of screw terminals connect to the 32 differential inputs of the VXI-SC submodule. Four terminals labeled *GND* connect to the submodule's chassis ground pins. The AIREF, AOREF, GUARD, OUTPUT, OUT0+, OUT0-, OUT1+, OUT1-, OUT2+, OUT2-, OUT3+, and OUT3- terminals are reserved for use with future VXI-SC submodules.

The VXI-TB-1303 terminal block has a pull-up resistor connected between CH+ and +5 V and a ground-reference resistor connected between CH- and chassis ground. This pull-up resistor helps you detect open thermocouples by detecting saturation of the VXI-SC submodule amplifier output. The ground-reference resistor references floating thermocouples to ground.

# What You Need to Get Started

---

To set up and use your VXI-TB-1303, you will need the following:

- VXI-TB-1303 terminal block
- VXI-TB-1303 32-Channel Isothermal Terminal Block Installation Guide*
- One package of four 10  $\Omega$  resistor networks
- VXI-TB-1000 terminal board carrier and documentation
- VXI-SC-1102 or other VXI-SC submodule(s) and documentation
- Long-nose pliers

## Signal Connection and Installation

---

Refer to the *VXI-TB-1000 Terminal Board Carrier Installation Guide* for instructions on connecting your signals and installing the VXI-TB-1303 terminal block.



**Warning:** *Do not connect hazardous voltage levels ( $\pm 42$  VAC peak or VDC) to this product.*

Figure 1 shows the VXI-TB-1303 terminal block parts locator diagram.

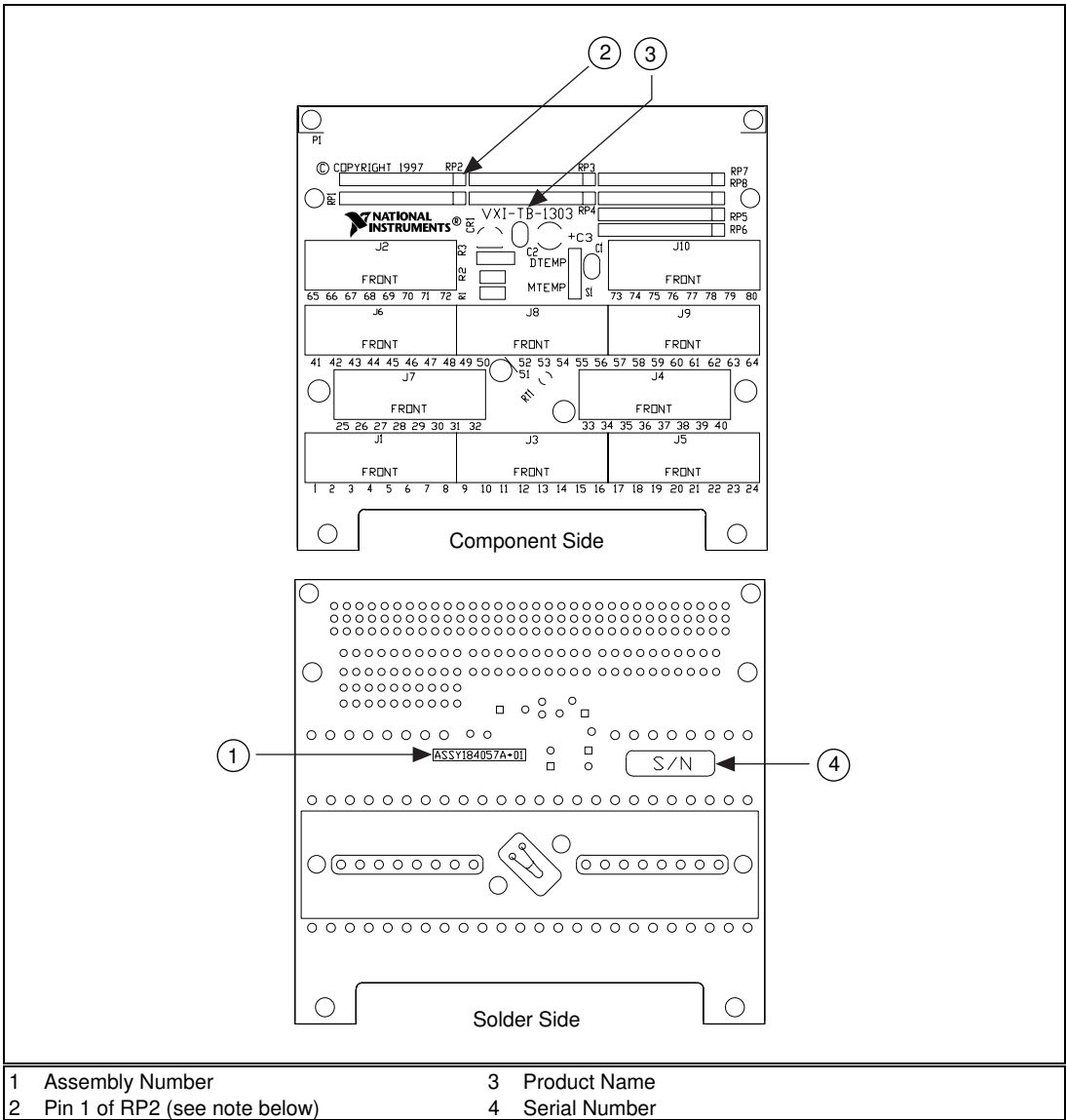

Figure 1. VXI-TB-1303 Parts Locator Diagram



**Note:**

*Notice that pin 1 is in the same location on each resistor network socket, and is represented by a square, in Figure 1.*

# Temperature Sensor and Switch Configuration



To enable you to use thermocouples with VXI-SC submodules, the VXI-TB-1303 terminal block has a thermistor temperature sensor for cold-junction compensation.

You can connect the temperature sensor to a VXI-SC submodule in either of two ways:

- Multiplexed Temperature Sensor (MTEMP) mode—Set the VXI-TB-1303 terminal block switch S1 to the MTEMP position. This is the factory-default setting.
- Direct Temperature Sensor (DTEMP) mode—Set the VXI-TB-1303 terminal block switch S1 to the DTEMP position. This mode connects the temperature sensor to a separate DAQ channel via your VXI-SC submodule. Refer to your VXI-SC submodule documentation to configure your VXI-SC submodule for DTEMP mode.

Table 1 shows the terminal block switch settings.

**Table 1.** Switch S1 Settings

Switch S1 Position	Description
 <p>MTEMP</p> <p>DTEMP</p>	MTEMP mode selected; factory-default setting; preferred mode and parking position
 <p>MTEMP</p> <p>DTEMP</p>	DTEMP mode selected; connect to a separate DAQ channel



**Note:**

*On the VXI-SC-1102 submodule, the MTEMP and DTEMP modes are equivalent.*

# Configuring the Resistor Networks

The 10 M $\Omega$  ground-reference networks are recommended for use with the VXI-SC-1102 and are factory installed.

The VXI-TB-1303 terminal block has a pull-up resistor connected between CH+ and +5 V and has a ground-reference resistor connected between CH- and chassis ground. Figure 2 shows how the pull-up and ground-reference resistors are connected to the CH $\pm$  inputs.

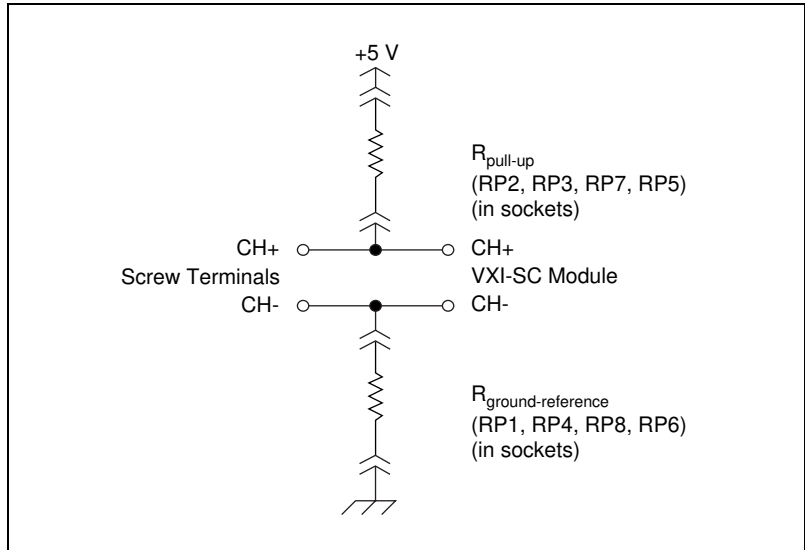

**Figure 2.** Resistor Connections

Table 2 shows the relationship between the channel input signals and the resistor networks.

**Table 2.** Channel Input Signals and Resistor Networks

Channel	Pull-up Resistor Network	Ground-Reference Resistor Network
0–7	RP2	RP1
8–15	RP3	RP4
16–23	RP7	RP8
24–31	RP5	RP6

Table 3 shows which resistor networks to use for your VXI-SC submodule, signal type, and application.

**Table 3.** Selecting the Appropriate Resistor Networks

Ground-Reference Resistor	Pull-up Resistor	Source Impedance	Signal (Floating or Ground-Referenced)	Open Thermocouple Detection?	Comments
10 M $\Omega$	10 M $\Omega$	Low	Both	Yes	Recommended configuration for the VXI-SC-1102. Factory-shipping configuration.
10 $\Omega$	10 M $\Omega$	Low	Floating	Yes	—
10 $\Omega$	None	High or low	Floating	No	—
None	None	High or low	Ground-referenced	No	—
Low source impedance $\leq 50 \Omega$ High source impedance $> 50 \Omega$					

A package of 10  $\Omega$  ground-reference resistor networks is included in the VXI-TB-1303 kit. These ground-reference resistor networks may be recommended for future VXI-SC submodules but are not recommended for the VXI-SC-1102 submodule. You can install them as RP2, RP3, RP7, and RP5.



**Warning:** *Connecting an external ground-referenced signal with the 10  $\Omega$  ground-reference resistor network in place may cause permanent damage to the resistor network and the traces on the VXI-TB-1303 printed circuit board. National Instruments is NOT liable for any damage or injuries resulting from improper signal connections.*

## Changing Resistor Networks

Use long-nose pliers to remove or replace the resistor networks in the sockets; be careful not to damage the network package. Make sure pin 1 of each network is in the correct position in the socket. Refer to Figure 1 for the pin 1 location for each resistor network socket. Notice that pin 1 is in the same location on each resistor network socket, and each one is represented by a square in the drawing.

Each resistor network is labeled with descriptive numbers on the left front side, and pin 1 is located directly beneath the darkened symbol within these numbers. The 10  $\Omega$  resistor network is labeled *100* ( $10 \times 10^0 \Omega$ ); the 10 M $\Omega$  resistor network is labeled *106* ( $10 \times 10^6 \Omega$ ). Figure 3 shows examples of these resistors.

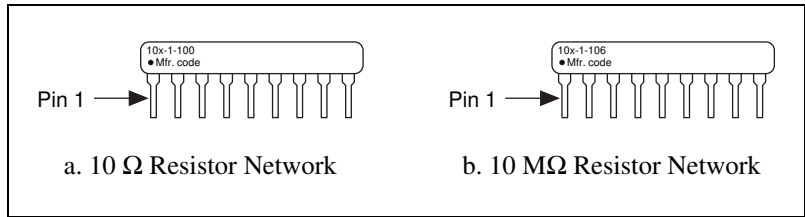

**Figure 3.** Resistor Networks

## Open-Thermocouple Detection

The VXI-TB-1303 circuitry helps you detect an open thermocouple. To detect whether any thermocouple is open, check whether the corresponding VXI-SC submodule channel is saturated. The VXI-TB-1303 has pull-up and ground-reference resistors that saturate the channel by applying +5 V at the input of the open channel. This will cause saturation to either of the positive or negative rails.

### VXI-SC-1102 Submodule

With the 10 M $\Omega$  ground-reference resistor networks, it does not matter whether your signal is ground-referenced or floating. The channels with open thermocouples will saturate at all sample rates of the submodule.

### Errors Due to Open-Thermocouple Detection Circuitry

Open-thermocouple detection circuitry can cause two types of measurement errors. These errors are caused by common-mode voltage at the input of the VXI-SC submodule and current leakage into your signal leads.

#### Common-Mode Voltage at the Input of the VXI-SC Submodule

With 10 M $\Omega$  pull-up and ground-reference resistor networks, a common-mode voltage of 2.5 VDC will develop if the thermocouple is floating. At a gain of 100, the common-mode rejection of the VXI-SC-1102 submodule is sufficiently high that the resulting offset voltage is negligible.



However, if your application demands extremely high accuracy, you can eliminate this offset error by calibrating your system. You can also remove the pull-up resistor network, giving up the open-thermocouple detection feature in the process, or use the 10  $\Omega$  ground-reference resistor networks, which will bring the common-mode voltage down to nearly 0 VDC.

## Current Leakage

The open-thermocouple detection circuitry causes a small current leakage into the thermocouple. The magnitude of this current depends on whether your thermocouple is grounded. The following calculation uses a 20-ft 24 AWG J-type thermocouple as an example. This example thermocouple has a resistance of 8.78  $\Omega$  per lead, based on the equation:

$$R_{\text{lead}} = 0.439 \text{ } \Omega/\text{ft} \times 20 \text{ ft} = 8.78 \text{ } \Omega \text{ per lead}$$

If your thermocouple is floating, as shown in Figure 4, a leakage current of approximately 0.25  $\mu\text{A}$  ( $5 \text{ V} / 20 \text{ M}\Omega$ ) will flow through both leads of your thermocouple. The resultant measurement error will be 4.4  $\mu\text{V}$  for the example thermocouple, based on the equation:

$$2 \text{ leads} \times 8.78 \text{ } \Omega / \text{lead} \times 0.25 \text{ } \mu\text{A} = 4.4 \text{ } \mu\text{V}$$

This corresponds to an error of 0.09° C.

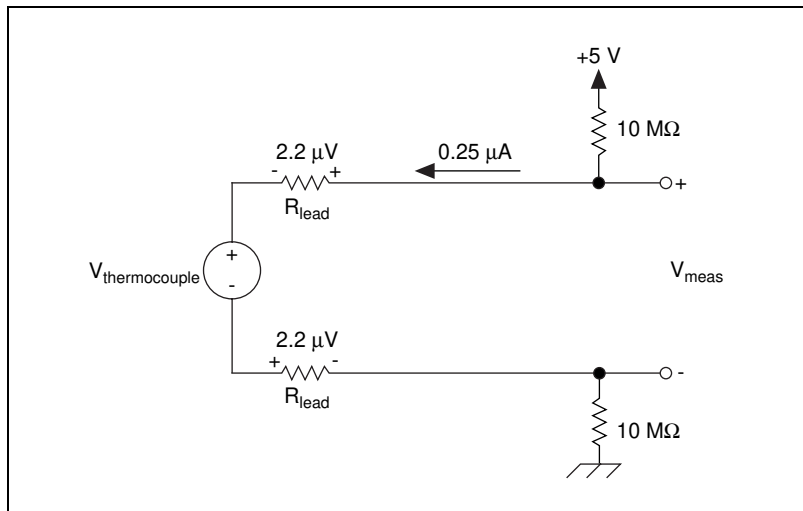
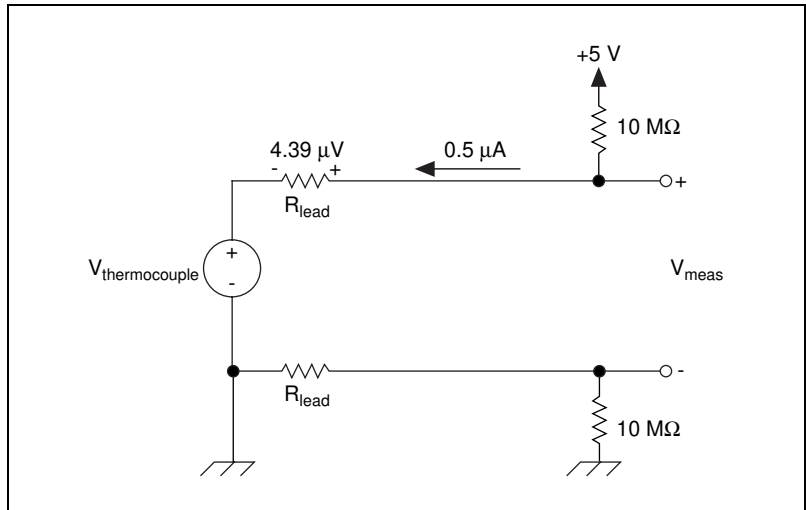

Figure 4. Floating Thermocouple

If your thermocouple is grounded on the negative lead, as shown in Figure 5, or grounded on the positive lead, as shown in Figure 6, a leakage current of approximately  $0.5 \mu\text{A}$  ( $5 \text{ V}/10 \text{ M}\Omega$ ) will flow through your thermocouple. The resultant measurement error will be  $4.4 \mu\text{V}$  for the example thermocouple, based on the equation:

$$1 \text{ lead} \times 8.78 \Omega / \text{lead} \times 0.5 \mu\text{A} = 4.4 \mu\text{V}$$

This corresponds to an error of  $0.09^\circ \text{C}$ .



**Figure 5.** Thermocouple with Negative Lead Grounded

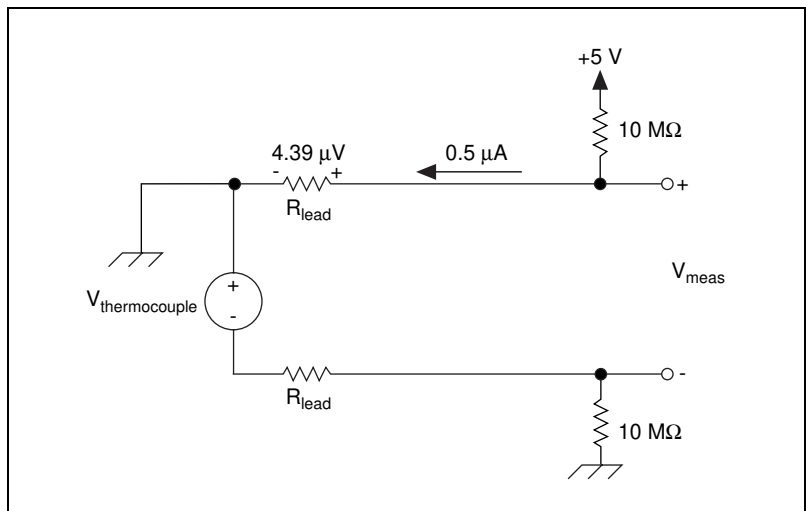

**Figure 6.** Thermocouple with Positive Lead Grounded

You can make similar calculations when you use a 10  $\Omega$  ground-reference resistor instead of a 10 M $\Omega$  resistor.

If your application demands very high accuracy, you can eliminate this error by removing the appropriate pull-up resistor network or by calibrating the system offset.

## Temperature Sensor Output and Accuracy

---

The VXI-TB-1303 temperature sensor voltage output varies from 1.91 to 0.58 V over the temperature range, as shown in Table 4.

**Table 4.** Temperature Sensor Voltage Output Accuracy

Temperature Range	Voltage Output Accuracy*
0° to 15° C	$\pm 1^\circ$ C
15° to 35° C	$\pm 0.65^\circ$ C
35° to 55° C	$\pm 1^\circ$ C
* Includes the combined effects of the temperature sensor accuracy and the temperature difference between the temperature sensor and any screw terminal. The temperature sensor accuracy includes tolerances in all component values, the effects caused by temperature and loading, and self-heating.	

To select and read the temperature sensor, refer to your LabVIEW, LabWindows<sup>®</sup>/CVI, NI-DAQ, or other software documentation for programming information.

Alternatively, you can use the following formulas to convert the cold-junction sensor voltage to cold-junction temperature:

$$T(^{\circ}\text{C}) = T_k - 273.15$$

where  $T_k$  is the temperature in kelvin

$$a = 1.295361 \times 10^{-3}$$

$$b = 2.343159 \times 10^{-4}$$

$$c = 1.018703 \times 10^{-7}$$

$R_T$  = resistance of the thermistor in  $\Omega$

$$R_T = 5,000 \Omega \left( \frac{V_{\text{TEMPOUT}}}{2.5 - V_{\text{TEMPOUT}}} \right)$$

$V_{\text{TEMPOUT}}$  = output voltage of the temperature sensor

$$T(^{\circ}\text{F}) = \frac{[T(^{\circ}\text{C})]9}{5} + 32$$

where  $T(^{\circ}\text{F})$  and  $T(^{\circ}\text{C})$  are the temperature readings in degrees Fahrenheit and Celsius, respectively.



**Note:**

$V_{\text{TEMPOUT}}$  varies from 1.91 V (at  $0^{\circ}\text{C}$ ) to 0.58 V (at  $55^{\circ}\text{C}$ ). For best resolution, use the maximum gain for this signal range on the analog input channel.

The VXI-SC-1102 has a 2 Hz filter on the  $V_{\text{TEMPOUT}}$  signal.

## Temperature Sensor Circuit Diagram

The circuit diagram in Figure 7 provides optional details about the VXI-TB-1303 temperature sensor.

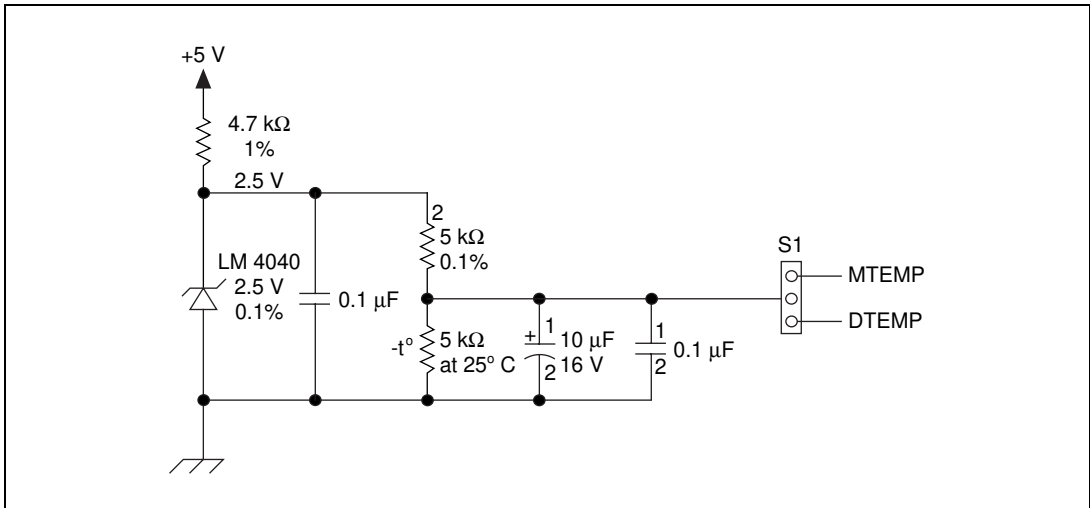

Figure 7. Temperature Sensor Circuit Diagram

# Specifications

---

## Cold-junction sensor

Accuracy <sup>1</sup> .....	0.65° C from 15° to 35° C 1.0° C from 0° to 15° and 35° to 55° C
Repeatability .....	0.35° C from 15° to 35° C
Output.....	1.91 (at 0° C) to 0.58 V (at 55° C)

## Open thermocouple detection

Pull-up resistor .....	10 M $\Omega$
Ground-reference resistor.....	10 $\Omega$ or 10 M $\Omega$
Maximum field wire gauge .....	26-14 AWG

## Maximum working voltage

(signal + common mode).....	Each input should remain within $\pm 10$ V of chassis ground
-----------------------------	---

<sup>1</sup> Includes the combined effects of the temperature sensor accuracy and the temperature difference between the temperature sensor and any screw terminal. The temperature sensor accuracy includes tolerances in all component values, the effects caused by temperature and loading, and self-heating.



321567A-01  
April 1997