

VXI

VXIpc™ 870 Series User Manual

Worldwide Technical Support and Product Information

www.ni.com

National Instruments Corporate Headquarters

11500 North Mopac Expressway Austin, Texas 78759-3504 USA Tel: 512 794 0100

Worldwide Offices

Australia 03 9879 5166, Austria 0662 45 79 90 0, Belgium 02 757 00 20, Brazil 011 284 5011,
Canada (Calgary) 403 274 9391, Canada (Ontario) 905 785 0085, Canada (Québec) 514 694 8521,
China 0755 3904939, Denmark 45 76 26 00, Finland 09 725 725 11, France 01 48 14 24 24,
Germany 089 741 31 30, Greece 30 1 42 96 427, Hong Kong 2645 3186, India 91805275406,
Israel 03 6120092, Italy 02 413091, Japan 03 5472 2970, Korea 02 596 7456, Mexico (D.F.) 5 280 7625,
Mexico (Monterrey) 8 357 7695, Netherlands 0348 433466, New Zealand 09 914 0488, Norway 32 27 73 00,
Poland 0 22 528 94 06, Portugal 351 1 726 9011, Singapore 2265886, Spain 91 640 0085,
Sweden 08 587 895 00, Switzerland 056 200 51 51, Taiwan 02 2528 7227, United Kingdom 01635 523545

For further support information, see the *Technical Support Resources* appendix. To comment on the documentation, send e-mail to techpubs@ni.com

© Copyright 1999, 2000 National Instruments Corporation. All rights reserved.

Important Information

Warranty

The VXIpc 870 Series embedded computers and accessories are warranted against defects in materials and workmanship for a period of one year from the date of shipment, as evidenced by receipts or other documentation. National Instruments will, at its option, repair or replace equipment that proves to be defective during the warranty period. This warranty includes parts and labor.

The media on which you receive National Instruments software are warranted not to fail to execute programming instructions, due to defects in materials and workmanship, for a period of 90 days from date of shipment, as evidenced by receipts or other documentation. National Instruments will, at its option, repair or replace software media that do not execute programming instructions if National Instruments receives notice of such defects during the warranty period. National Instruments does not warrant that the operation of the software shall be uninterrupted or error free.

A Return Material Authorization (RMA) number must be obtained from the factory and clearly marked on the outside of the package before any equipment will be accepted for warranty work. National Instruments will pay the shipping costs of returning to the owner parts which are covered by warranty.

National Instruments believes that the information in this document is accurate. The document has been carefully reviewed for technical accuracy. In the event that technical or typographical errors exist, National Instruments reserves the right to make changes to subsequent editions of this document without prior notice to holders of this edition. The reader should consult National Instruments if errors are suspected. In no event shall National Instruments be liable for any damages arising out of or related to this document or the information contained in it.

EXCEPT AS SPECIFIED HEREIN, NATIONAL INSTRUMENTS MAKES NO WARRANTIES, EXPRESS OR IMPLIED, AND SPECIFICALLY DISCLAIMS ANY WARRANTY OF MERCHANTABILITY OR FITNESS FOR A PARTICULAR PURPOSE. CUSTOMER'S RIGHT TO RECOVER DAMAGES CAUSED BY FAULT OR NEGLIGENCE ON THE PART OF NATIONAL INSTRUMENTS SHALL BE LIMITED TO THE AMOUNT THEREFORE PAID BY THE CUSTOMER. NATIONAL INSTRUMENTS WILL NOT BE LIABLE FOR DAMAGES RESULTING FROM LOSS OF DATA, PROFITS, USE OF PRODUCTS, OR INCIDENTAL OR CONSEQUENTIAL DAMAGES, EVEN IF ADVISED OF THE POSSIBILITY THEREOF. This limitation of the liability of National Instruments will apply regardless of the form of action, whether in contract or tort, including negligence. Any action against National Instruments must be brought within one year after the cause of action accrues. National Instruments shall not be liable for any delay in performance due to causes beyond its reasonable control. The warranty provided herein does not cover damages, defects, malfunctions, or service failures caused by owner's failure to follow the National Instruments installation, operation, or maintenance instructions; owner's modification of the product; owner's abuse, misuse, or negligent acts; and power failure or surges, fire, flood, accident, actions of third parties, or other events outside reasonable control.

Copyright

Under the copyright laws, this publication may not be reproduced or transmitted in any form, electronic or mechanical, including photocopying, recording, storing in an information retrieval system, or translating, in whole or in part, without the prior written consent of National Instruments Corporation.

Trademarks

CVI™, LabVIEW™, MANTIS™, MITE™, National Instruments™, NI-488.2™, ni.com™, NI-VISA™, NI-VXI™, TNT4882C™, and VXIpc™ are trademarks of National Instruments Corporation.

Product and company names mentioned herein are trademarks or trade names of their respective companies.

WARNING REGARDING USE OF NATIONAL INSTRUMENTS PRODUCTS

(1) NATIONAL INSTRUMENTS PRODUCTS ARE NOT DESIGNED WITH COMPONENTS AND TESTING FOR A LEVEL OF RELIABILITY SUITABLE FOR USE IN OR IN CONNECTION WITH SURGICAL IMPLANTS OR AS CRITICAL COMPONENTS IN ANY LIFE SUPPORT SYSTEMS WHOSE FAILURE TO PERFORM CAN REASONABLY BE EXPECTED TO CAUSE SIGNIFICANT INJURY TO A HUMAN.

(2) IN ANY APPLICATION, INCLUDING THE ABOVE, RELIABILITY OF OPERATION OF THE SOFTWARE PRODUCTS CAN BE IMPAIRED BY ADVERSE FACTORS, INCLUDING BUT NOT LIMITED TO FLUCTUATIONS IN ELECTRICAL POWER SUPPLY, COMPUTER HARDWARE MALFUNCTIONS, COMPUTER OPERATING SYSTEM SOFTWARE FITNESS, FITNESS OF COMPILERS AND DEVELOPMENT SOFTWARE USED TO DEVELOP AN APPLICATION, INSTALLATION ERRORS, SOFTWARE AND HARDWARE COMPATIBILITY PROBLEMS, MALFUNCTIONS OR FAILURES OF ELECTRONIC MONITORING OR CONTROL DEVICES, TRANSIENT FAILURES OF ELECTRONIC SYSTEMS (HARDWARE AND/OR SOFTWARE), UNANTICIPATED USES OR MISUSES, OR ERRORS ON THE PART OF THE USER OR APPLICATIONS DESIGNER (ADVERSE FACTORS SUCH AS THESE ARE HEREAFTER COLLECTIVELY TERMED "SYSTEM FAILURES"). ANY APPLICATION WHERE A SYSTEM FAILURE WOULD CREATE A RISK OF HARM TO PROPERTY OR PERSONS (INCLUDING THE RISK OF BODILY INJURY AND DEATH) SHOULD NOT BE RELIANT SOLELY UPON ONE FORM OF ELECTRONIC SYSTEM DUE TO THE RISK OF SYSTEM FAILURE. TO AVOID DAMAGE, INJURY, OR DEATH, THE USER OR APPLICATION DESIGNER MUST TAKE REASONABLY PRUDENT STEPS TO PROTECT AGAINST SYSTEM FAILURES, INCLUDING BUT NOT LIMITED TO BACK-UP OR SHUT DOWN MECHANISMS. BECAUSE EACH END-USER SYSTEM IS CUSTOMIZED AND DIFFERS FROM NATIONAL INSTRUMENTS' TESTING PLATFORMS AND BECAUSE A USER OR APPLICATION DESIGNER MAY USE NATIONAL INSTRUMENTS' PRODUCTS IN COMBINATION WITH OTHER PRODUCTS IN A MANNER NOT EVALUATED OR CONTEMPLATED BY NATIONAL INSTRUMENTS, THE USER OR APPLICATION DESIGNER IS ULTIMATELY RESPONSIBLE FOR VERIFYING AND VALIDATING THE SUITABILITY OF NATIONAL INSTRUMENTS PRODUCTS WHENEVER NATIONAL INSTRUMENTS PRODUCTS ARE INCORPORATED IN A SYSTEM OR APPLICATION, INCLUDING, WITHOUT LIMITATION, THE APPROPRIATE DESIGN, PROCESS AND SAFETY LEVEL OF SUCH SYSTEM OR APPLICATION.

Compliance

FCC/Canada Radio Frequency Interference Compliance*

Determining FCC Class

The Federal Communications Commission (FCC) has rules to protect wireless communications from interference. The FCC places digital electronics into two classes. These classes are known as Class A (for use in industrial-commercial locations only) or Class B (for use in residential or commercial locations). Depending on where it is operated, this product could be subject to restrictions in the FCC rules. (In Canada, the Department of Communications (DOC), of Industry Canada, regulates wireless interference in much the same way.)

Digital electronics emit weak signals during normal operation that can affect radio, television, or other wireless products. By examining the product you purchased, you can determine the FCC Class and therefore which of the two FCC/DOC Warnings apply in the following sections. (Some products may not be labeled at all for FCC; if so, the reader should then assume these are Class A devices.)

FCC Class A products only display a simple warning statement of one paragraph in length regarding interference and undesired operation. Most of our products are FCC Class A. The FCC rules have restrictions regarding the locations where FCC Class A products can be operated.

FCC Class B products display either a FCC ID code, starting with the letters **EXN**, or the FCC Class B compliance mark that appears as shown here on the right.

Consult the FCC web site <http://www.fcc.gov> for more information.

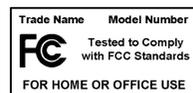

FCC/DOC Warnings

This equipment generates and uses radio frequency energy and, if not installed and used in strict accordance with the instructions in this manual and the CE Mark Declaration of Conformity**, may cause interference to radio and television reception. Classification requirements are the same for the Federal Communications Commission (FCC) and the Canadian Department of Communications (DOC).

Changes or modifications not expressly approved by National Instruments could void the user's authority to operate the equipment under the FCC Rules.

Class A

Federal Communications Commission

This equipment has been tested and found to comply with the limits for a Class A digital device, pursuant to part 15 of the FCC Rules. These limits are designed to provide reasonable protection against harmful interference when the equipment is operated in a commercial environment. This equipment generates, uses, and can radiate radio frequency energy and, if not installed and used in accordance with the instruction manual, may cause harmful interference to radio communications. Operation of this equipment in a residential area is likely to cause harmful interference in which case the user will be required to correct the interference at his own expense.

Canadian Department of Communications

This Class A digital apparatus meets all requirements of the Canadian Interference-Causing Equipment Regulations.

Cet appareil numérique de la classe A respecte toutes les exigences du Règlement sur le matériel brouilleur du Canada.

Class B

Federal Communications Commission

This equipment has been tested and found to comply with the limits for a Class B digital device, pursuant to part 15 of the FCC Rules. These limits are designed to provide reasonable protection against harmful interference in a residential installation. This equipment generates, uses and can radiate radio frequency energy and, if not installed and used in accordance with the instructions, may cause harmful interference to radio communications. However, there is no guarantee that interference will not occur in a particular installation. If this equipment does cause harmful interference to radio or television reception, which can be determined by turning the equipment off and on, the user is encouraged to try to correct the interference by one or more of the following measures:

- Reorient or relocate the receiving antenna.
- Increase the separation between the equipment and receiver.

- Connect the equipment into an outlet on a circuit different from that to which the receiver is connected.
- Consult the dealer or an experienced radio/TV technician for help.

Canadian Department of Communications

This Class B digital apparatus meets all requirements of the Canadian Interference-Causing Equipment Regulations.

Cet appareil numérique de la classe B respecte toutes les exigences du Règlement sur le matériel brouilleur du Canada.

European Union - Compliance to EEC Directives

Readers in the EU/EEC/EEA must refer to the Manufacturer's Declaration of Conformity (DoC) for information** pertaining to the CE Mark compliance scheme. The Manufacturer includes a DoC for most every hardware product except for those bought for OEMs, if also available from an original manufacturer that also markets in the EU, or where compliance is not required as for electrically benign apparatus or cables.

* Certain exemptions may apply in the USA, see FCC Rules §15.103 **Exempted devices**, and §15.105(c). Also available in sections of CFR 47.

** The CE Mark Declaration of Conformity will contain important supplementary information and instructions for the user or installer.

Contents

About This Manual

Conventions Used in This Manual.....	xiii
How to Use This Documentation Set	xiv
Related Documentation.....	xiv

Chapter 1

Introduction

Overview.....	1-1
Standard Equipment.....	1-4
National Instruments Software	1-4
Driver Software	1-4
Application Software.....	1-5

Chapter 2

Configuration and Installation

What You Need to Get Started	2-1
Installing the VXIpc 870 Series.....	2-1
Installing and Removing Flash Memory in the VXIpc-873	2-3
Installing the Flash Storage Card	2-3
Removing the Flash Storage Card.....	2-3

Chapter 3

Configuration and Default Settings

Hardware Default Settings.....	3-1
Software Default Settings	3-3
VXI-MXI-2.....	3-4
Configuring the VXIpc 870 Series	3-5
Accessing the Hardware Switches.....	3-5
VXIbus System Controller/Non-System Controller.....	3-6
VXIbus CLK10 Routing and Termination	3-7
Trigger Input Termination.....	3-7
MITE EEPROM	3-7
How to Fix an Invalid EEPROM Configuration.....	3-8
Configuring the PC	3-9
SCSI Termination.....	3-10
System CMOS	3-10
CPU Bus Speed	3-11

CPU Bus Factor	3-12
Flash Protection.....	3-12
Ethernet Serial EEPROM.....	3-13
Voltage Monitor	3-13
NI WatchDOG	3-13
Installing Additional Memory.....	3-13
Changing the Main Power Fuse	3-14

Chapter 4 Developing Your Application

Configuration.....	4-1
Device Interaction	4-2
Programming with VXI.....	4-4
Notes about VME Support.....	4-5
Compiler Symbols for NI-VXI	4-5
Debugging	4-6

Chapter 5 Functional Overview

VXIpc 870 Series Functional Description.....	5-1
Processor	5-2
Chip Set and SDRAM.....	5-2
AGP Graphics	5-3
10/100 Ethernet and SCSI-3	5-3
PC CARD Expansion.....	5-3
PCI or ISA Expansion.....	5-4
IEEE 488.2/HS488 Interface.....	5-4
PIIX4	5-4
Super IO	5-4
NI WatchDOG	5-4
Real-Time Clock	5-5
BIOS.....	5-5
Programmable Reset Circuitry.....	5-5
VXI Voltage Monitor Circuitry	5-5
Fused Power Protection	5-5
VXI Bus	5-6
VXI Addressing	5-6
DMA Transfers to and from VXI	5-6
VXI Slot 0 Functionality	5-6
External VXI CLK10 Synchronization	5-7
VXI Trigger Lines	5-7
VXI Interrupts.....	5-7

Chapter 6 BIOS

Entering BIOS Setup	6-1
Default BIOS Setup Settings	6-1

Appendix A Specifications

Appendix B LED Indicators

Appendix C Front Panel and Connectors

Appendix D Modifying and Installing I/O Expansion Boards

Appendix E Common Questions

Appendix F Technical Support Resources

Glossary

Index

Figures

Figure 1-1.	VXIpc-871 Embedded Controller	1-1
Figure 1-2.	VXIpc-872 Embedded Controller	1-2
Figure 1-3.	VXIpc-873 Embedded Controller (Option 1 with an Internal, Nonremovable Flash Drive)	1-2
Figure 1-4.	VXIpc-873 Embedded Controller (Option 2 with a Removable Flash Drive).....	1-3
Figure 2-1.	Installing and Removing a Flash Storage Card	2-4

Figure 3-1.	VXIpc 870 Series Parts Locator Diagram	3-1
Figure 3-2.	System Controller Slot Configuration	3-6
Figure 3-3.	Power-on Self Configuration Status	3-8
Figure 3-4.	EEPROM Configuration	3-8
Figure 3-5.	SCSI Termination	3-10
Figure 3-6.	System CMOS	3-11
Figure 3-7.	CPU Bus Speed Configuration	3-11
Figure 3-8.	CPU Bus Factor Jumper Settings.....	3-12
Figure 3-9.	Flash Protection Settings.....	3-12
Figure 3-10.	Ethernet Serial EEPROM Settings.....	3-13
Figure 3-11.	Voltage Monitor Settings.....	3-13
Figure 3-12.	Main Power Fuse Replacement	3-14
Figure 5-1.	VXIpc 870 Series Block Diagram	5-2
Figure C-1.	VXIpc-871 Front Panel Layout and Dimensions.....	C-2
Figure C-2.	VXIpc-872 Front Panel Layout and Dimensions.....	C-3
Figure C-3.	VXIpc-873 Front Panel Layout and Dimensions (Option 1 with Internal, Nonremovable Flash Drive).....	C-4
Figure C-4.	VXIpc-873 Front Panel Layout and Dimensions (Option 2 with Removable Flash Drive).....	C-5
Figure C-5.	Keyboard and Mouse Connectors Location and Pinout	C-6
Figure C-6.	SVGA Connector Location and Pinout.....	C-7
Figure C-7.	Ethernet Connector Location and Pinout.	C-8
Figure C-8.	COM1 and COM2 Connectors Location and Pinout.	C-9
Figure C-9.	Parallel Port Connector Location and Pinout.....	C-10
Figure C-10.	USB Connectors Location and Pinout	C-12
Figure C-11.	SCSI Connector Location and Pinout	C-13
Figure C-12.	GPIB Connector Location and Pinout	C-15
Figure C-13.	SMB Connectors Location and Pinout	C-17
Figure C-14.	Speaker Connection Location	C-18
Figure C-15.	VXIbus Connectors Location and Pinout	C-19
Figure D-1.	I/O Board Dimensions for VXIpc-872 Expansion Slot	D-1
Figure D-2.	PCI Board and ISA Board Installed in a VXIpc-872 or VXIpc-873	D-3
Figure D-3.	Front View of PCI Board Expansion Bracket.....	D-3
Figure D-4.	Front View of ISA Board Expansion Bracket	D-4

Tables

Table 3-1.	VXIpc 870 Series Hardware Default Settings.....	3-2
Table 3-2.	VXIpc T&M Explorer Device Tab Default Settings.....	3-3
Table 3-3.	VXIpc T&M Explorer Shared Memory Tab Default Settings	3-3
Table 3-4.	VXIpc T&M Explorer PCI Tab Default Settings.....	3-3
Table 3-5.	VXI-MXI-2 T&M Explorer Device Tab Default Settings	3-4
Table 3-6.	VXI-MXI-2 T&M Explorer VXI Bus Tab Default Settings.....	3-4
Table 3-7.	VXI-MXI-2 T&M Explorer MXI-2 Bus Tab Default Settings.....	3-5
Table 4-1.	NI-VXI/VISA Examples	4-4
Table B-1.	LEDs and System Startup Status.....	B-2
Table C-1.	Keyboard and Mouse Connector Signals	C-6
Table C-2.	SVGA Connector Signals.....	C-7
Table C-3.	Ethernet Connector Signals	C-9
Table C-4.	COM1 and COM2 Connector Signals.....	C-10
Table C-5.	Parallel Port Connector Signals.....	C-11
Table C-6.	USB Connector Signals.....	C-12
Table C-7.	16-Bit Wide SCSI-3 “P” (Primary) Connector Pinout (Single Ended).....	C-13
Table C-8.	GPIB Connector Signals	C-16
Table C-9.	SMB Connector Signals	C-17
Table C-10.	Signal Characteristics for SMB and Speaker Connections	C-18
Table C-11.	VXIbus P1 Connector Signals.....	C-19
Table C-12.	VXIbus P2 Connector Signals.....	C-20

About This Manual

This manual contains instructions for installing and configuring the National Instruments VXIpc 870 Series embedded computer kit. The VXIpc 870 Series includes all the models of the VXIpc 870 embedded computers.

Conventions Used in This Manual



The following conventions are used in this manual:

This icon denotes a note, which alerts you to important information.



This icon denotes a caution, which advises you of precautions to take to avoid injury, data loss, or a system crash.



This icon denotes a warning, which advises you of precautions to take to avoid being electrically shocked.

bold

Bold text denotes items that you must select or click on in the software, such as menu items and dialog box options. Bold text also denotes parameter names.

italic

Italic text denotes variables, emphasis, a cross reference, or an introduction to a key concept. This font also denotes text that is a placeholder for a word or value that you must supply.

`monospace`

Text in this font denotes text or characters that you should enter from the keyboard, sections of code, programming examples, and syntax examples. This font is also used for the proper names of disk drives, paths, directories, programs, subprograms, subroutines, device names, functions, operations, variables, filenames and extensions, and code excerpts.

`monospace bold`

Bold text in this font denotes the messages and responses that the computer automatically prints to the screen. This font also emphasizes lines of code that are different from the other examples.

VXIpc 870 Series

The term *VXIpc 870 Series* refers to a series of C-size, two-slot VXI embedded controllers. Currently, this series consists of the VXIpc-871, VXIpc-872 and the VXIpc-873.

How to Use This Documentation Set

Begin by reading the *Read Me First VXIpc 870 Series for Windows NT/98* manual.

This manual, the *VXIpc 870 Series User Manual*, contains more details about changing the installation or configuration from the defaults, and using the hardware.

When you are familiar with the material in these manuals, you can begin to use the *NI-VXI User Manual*. This manual presents the concepts of VXI and prepares you for detailed explanations of the NI-VXI functions. The NI-VXI online help describes the NI-VXI functions to help you fully understand the purpose and syntax of each function. You can find this same information in the *NI-VXI Programmer Reference Manual*. These two manuals are available in the `c:\NIVXI\Manuals` directory under the names `NI-VXIUsersMan.pdf` and `NI-VXIProgrammerMan.pdf`, respectively. Use the Acrobat Reader program, Version 3 or later, to open these files.

You can also access the NI-VXI online help for Windows in the `NIVXI` folder.

Refer to the *NI-VISA User Manual* to learn about VISA and how to use it in your system. The NI-VISA online help describes the attributes, events, and operations you can use in NI-VISA. You can find this same information in the *NI-VISA Programmer Reference Manual*. These two manuals are available in the `c:\Vxipnp\os\NIVisa\Manuals` directory (where `os` is either `Win95` or `WinNT`) under the names `NI-VISAUsersMan.pdf` and `NI-VISAProgrammersMan.pdf`, respectively. Use the Acrobat Reader program, Version 3 or later, to open these files.

Related Documentation

The following documents contain information that you may find helpful as you read this manual:

- ANSI/IEEE Standard 1014-1987, *IEEE Standard for a Versatile Backplane Bus: VMEbus*
- ANSI/IEEE Standard 1155-1998, *IEEE VMEbus Extensions for Instrumentation: VXIbus*
- ANSI/VITA 1-1994, *VME64*
- VXI-6, *VXIbus Mainframe Extender Specification*, Rev. 2.0, VXIbus Consortium

Introduction

This chapter describes the VXIpc 870 Series of embedded VXI computers, lists standard equipment, and describes driver and application software.

Overview

The VXIpc 870 Series consists of the VXIpc-871, VXIpc-872, and VXIpc-873 models, which are functionally equivalent in many ways. These three models differ in that the VXIpc-871 has an internal CD-ROM drive, while the VXIpc-872 has one AT/PCI expansion slot. The VXIpc-873 has either an internal, nonremovable flash drive and one AT/PCI expansion slot or a removable flash drive.

The following four figures show the models with their covers removed. Refer to Appendix C, *Front Panel and Connectors*, for information about the location and pinout assignment of each connector on the modules.

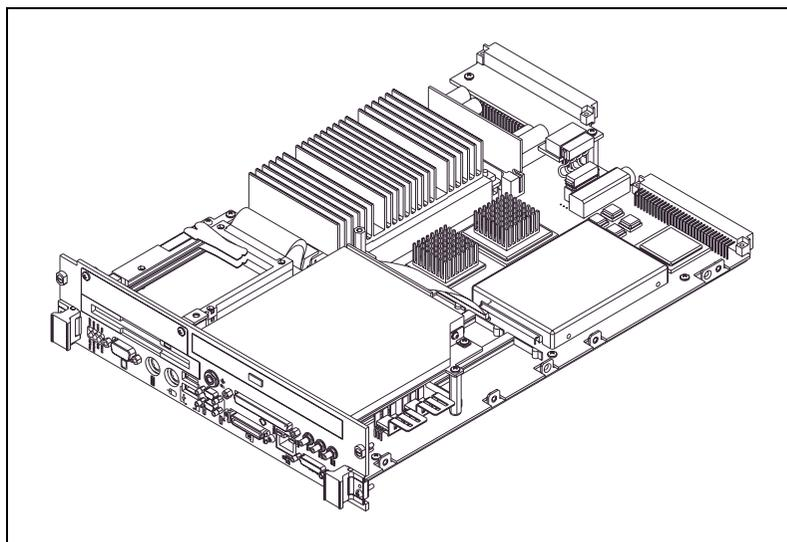

Figure 1-1. VXIpc-871 Embedded Controller

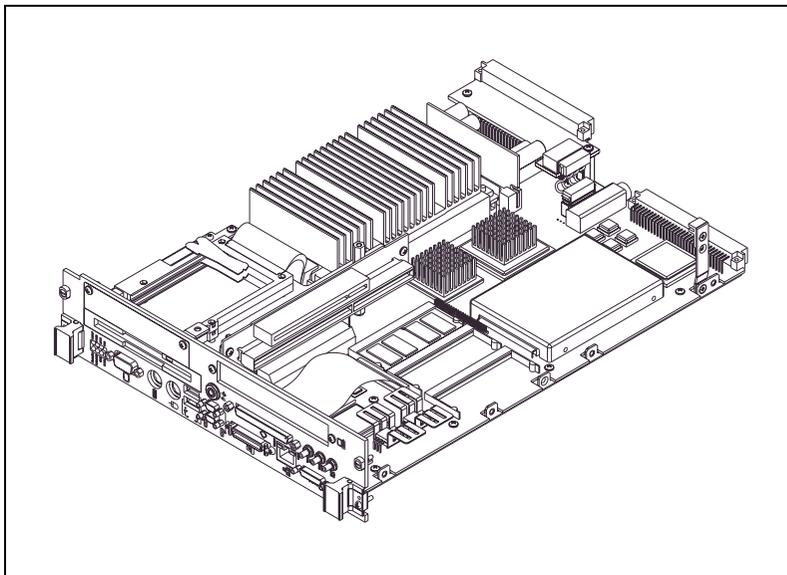

Figure 1-2. VXIpc-872 Embedded Controller

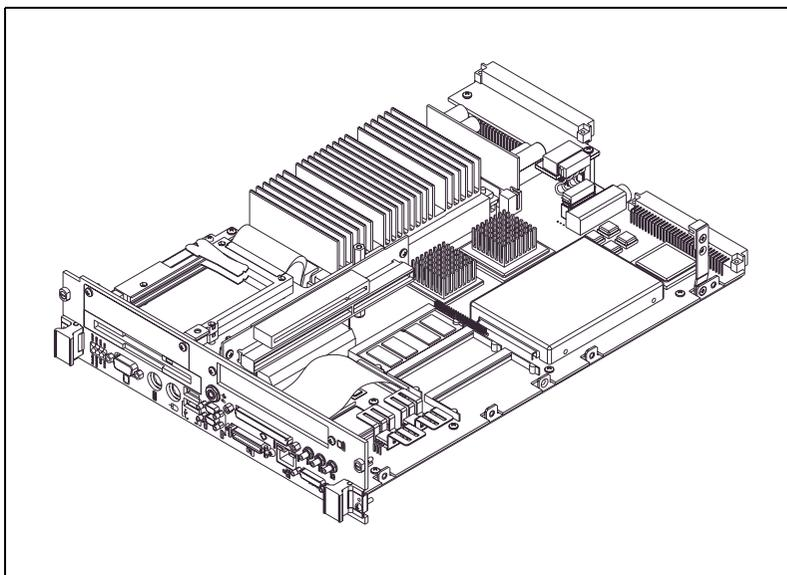

Figure 1-3. VXIpc-873 Embedded Controller (Option 1 with an Internal, Nonremovable Flash Drive)

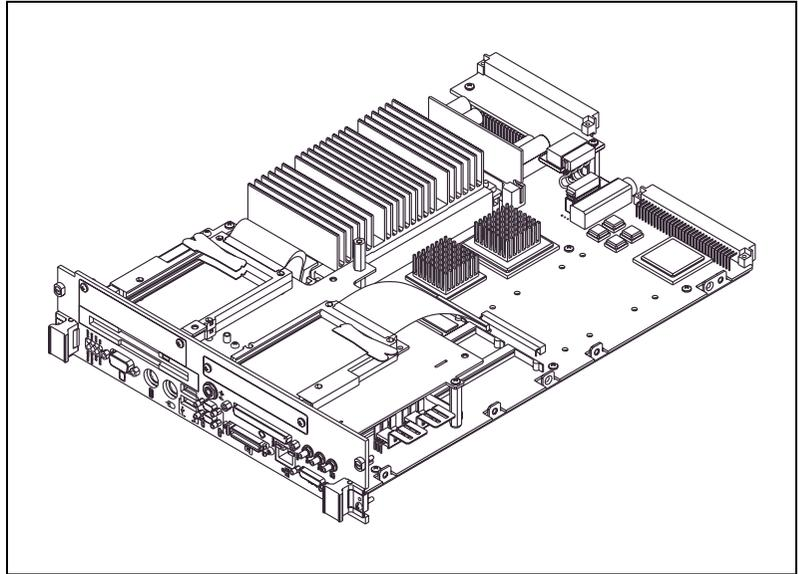

Figure 1-4. VXIpc-873 Embedded Controller (Option 2 with a Removable Flash Drive)

The VXIpc 870 Series controllers are C-size, embedded computers based on the x86 Processor architecture, the Peripheral Component Interface (PCI) bus, and the Advanced Graphics Port (AGP). These computers are high-performance, easy-to-use platforms for controlling VXIbus systems, featuring complete VXI functionality through interactive utilities and C function calls. In addition, the VXIpc 870 Series has Ethernet capability plus an IEEE 488.2 interface that is compatible with the NI-488.2 architecture.

The VXIpc 870 Series is a custom computer that you install directly in two C-size slots of your VXI mainframe. An embedded computer can take full advantage of the VXI high-performance backplane capabilities and give you direct control of VXI registers, memory, interrupts, and triggers.

All models in the VXIpc 870 Series are fully *VXIplug&play* compliant and are compatible with PC-compatible software tools, the National Instruments LabVIEW and LabWindows/CVI application software, and the NI-VXI, NI-VISA, and NI-488.2 bus interface software.

Standard Equipment

Your hardware includes the VXIpc 870 Series controller, which you install in your VXI mainframe. You also receive the following accessories:

- COM1/2 adapter cable
- Enhanced parallel port adapter cable
- Single-shielded 2 m GPIB cable
- AT-PS/2 cable

National Instruments Software

National Instruments has developed several software kits you can use with the VXIpc 870 Series.

Driver Software

NI-VXI is the name of the National Instruments VXI bus control library. You can create applications using NI-VXI to control both VXI and VME devices. NI-VXI gives you complete VXI/VME functionality, including an API for performing basic VXI/VME data transfers and handling VXI/VME interrupts as well as VXI-specific functionality, such as doing message-based communication and handling VXIbus triggers.

NI-VISA is the National Instruments implementation of the VISA specification. VISA is a uniform API for communicating and controlling Serial, GPIB, VXI, and VME instruments. This API aids in the creation of more portable applications and instrument drivers.

The NI-VXI/VISA software includes an interactive configuration and troubleshooting program, libraries of software routines for test and measurement (T&M) programming, interactive control programs for both NI-VXI and NI-VISA, a logging utility you can use for debugging your applications, and a VXI Resource Manager. You can use this software to seamlessly program multiple-mainframe configurations and have software compatibility across a variety of controller platforms.

The NI-488.2M software kit gives you access to the industry-standard NI-488.2M software for controlling external GPIB instruments through the GPIB port on the front panel of your VXIpc 870 Series. The GPIB interface on your VXIpc controller is fully compatible with the NI-488.2M driver for a variety of operating systems. Any software using NI-488.2M will run on the VXIpc 870 Series.

Application Software

You can also use the National Instruments LabVIEW and LabWindows/CVI application programs and instrument drivers to ease your programming task. These standardized programs match the modular virtual instrument capability of VXI and can reduce your VXI software development time. These programs are fully *VXIplug&play* compliant and feature extensive libraries of GPIB, Serial, and VXI instrument drivers written to take full advantage of direct VXI control. LabVIEW and LabWindows/CVI include all the tools needed for instrument control, data acquisition, analysis, and presentation.

LabVIEW is a complete programming environment that departs from the sequential nature of traditional programming languages and features a graphical programming environment.

LabWindows/CVI is an interactive C development environment for building test and measurement and instrument control systems. It includes interactive code-generation tools and a graphical editor for building custom user interfaces.

Configuration and Installation

This chapter contains the instructions to configure and install the VXIpc 870 Series. Unless otherwise noted, these instructions apply to all models in the VXIpc 870 Series, which currently consists of the VXIpc-871, VXIpc-872, and VXIpc-873.



Caution Electrostatic discharge can damage several components on your VXIpc 870 Series module. To avoid such damage in handling the module, touch the antistatic plastic package to a metal part of your VXI mainframe before removing the module from the package.

What You Need to Get Started

- VXIpc 870 Series embedded controller
- VXIbus mainframe
- Keyboard
- Mouse
- Monitor with VGA or better resolution
- National Instruments software media for the VXIpc 870 Series

The NI-VXI/VISA software is already installed on your VXIpc 870 Series computer. It is also included on CD-ROM in the event that you need to reinstall your software. The CD-ROM includes disk images if you need to make floppies for reinstallation.

Installing the VXIpc 870 Series

This section contains general installation instructions for the VXIpc 870 Series. Consult your VXIbus mainframe user manual or technical reference manual for specific instructions and warnings.

1. Plug in your mainframe before installing the VXIpc 870 Series. The power cord grounds the mainframe and protects it from electrical damage while you are installing the module.



Warning To protect both yourself and the mainframe from electrical hazards, the mainframe should remain off until you are finished installing the VXIpc 870 Series module.

2. Remove or open any doors or covers blocking access to the mainframe slots.



Caution If the VXIpc 870 Series is not configured for automatic System Controller detection, be certain that the slot you select in your VXIbus mainframe matches the VXIpc 870 Series configuration as either a System Controller device or a Non-System Controller device. Installing the VXIpc 870 Series into a slot that does not correspond with the jumper setting can damage the VXIpc 870 Series, the VXIbus backplane, or both.

3. Insert the VXIpc 870 Series in the slot you have selected by aligning the top and bottom of the module with the card-edge guides inside the mainframe. Slowly push the VXIpc 870 Series straight into the slot until its plug connectors are resting on the backplane receptacle connectors. Using slow, evenly distributed pressure, press the module straight in until it seats in the expansion slot. The front panel of the VXIpc 870 Series should be even with the front panel of the mainframe.
4. Tighten the retaining screws on the top and bottom edges of the front panel.
5. Check the installation.
6. Connect the keyboard and mouse to the appropriate connectors. Use the keyboard adapter cable that you received with your kit to adapt AT-style keyboards to the VXIpc 870 Series mini-DIN connector.
7. Connect the VGA monitor video cable to the VGA connector.
8. Connect devices to ports as required by your system configuration. Some ports, such as the COM and LPT ports, have adapter cables that came in your kit.
9. Replace or close any doors or covers to the mainframe.
10. Turn on the VXI mainframe.
11. The VXIpc 870 Series should now boot into either Windows 98 or NT.
12. On the first boot of the VXIpc 870 Series, a setup program automatically runs.
13. Follow the prompts in the setup program to fully configure your VXIpc 870 Series.
14. When prompted for the NT/98 serial number, enter the serial number of the operating system from the included certificate.

15. The next prompt asks if you purchased LabVIEW or LabWindows/CVI. Select the appropriate boxes and insert the disks when prompted.
16. Your VXIpc 870 Series is now ready for development.
17. Refer to Chapter 4, *Developing Your Application*, for more information.

Installing and Removing Flash Memory in the VXIpc-873

If your VXIpc-873 has removable flash memory, follow these instructions to install and remove the flash storage card.

Installing the Flash Storage Card

1. Turn off the VXI mainframe.



Warning Always turn off the mainframe while installing or removing the flash memory. Failure to turn off the mainframe will damage the VXIpc-873, the storage card, or both.

2. Remove the two screws and cover panel on the VXIpc-873 as shown in Figure 2-1.
3. Align the connector end of the flash storage card with the flash storage card carrier.
4. Slide the card into the carrier until you feel resistance. Press the card firmly into the carrier until the ejector button at the bottom of the drive slot slides forward.
5. Reinstall the cover plate and screws.

Removing the Flash Storage Card

1. Turn off the VXI mainframe.



Warning Always turn off the mainframe while installing or removing the flash memory. Failure to turn off the mainframe will damage the VXIpc-873, the storage card, or both.

2. Remove the two screws and cover panel on the VXIpc-873 as shown in Figure 2-1.

3. Press the ejector button at the bottom of the flash drive carrier slot until the flash storage card pops out of the drive.
4. Slide the card out of the drive.

Reinstall the cover plate and screws.

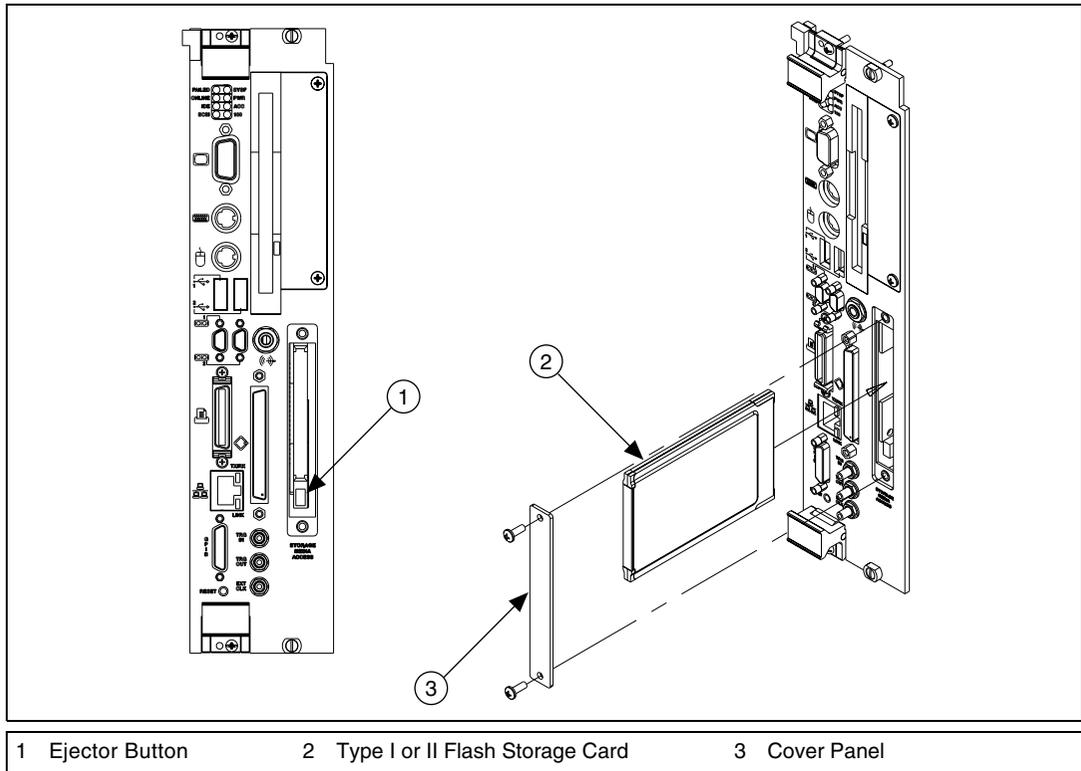

Figure 2-1. Installing and Removing a Flash Storage Card

Configuration and Default Settings

Hardware Default Settings

This chapter summarizes the hardware default settings for the VXIpc 870 Series for easy reference. The module is set at the factory for the most commonly used configuration.

Figure 3-1 shows the location of the user-configurable jumpers and switches on the VXIpc 870 Series. The diagram also shows the location of the serial and assembly numbers.

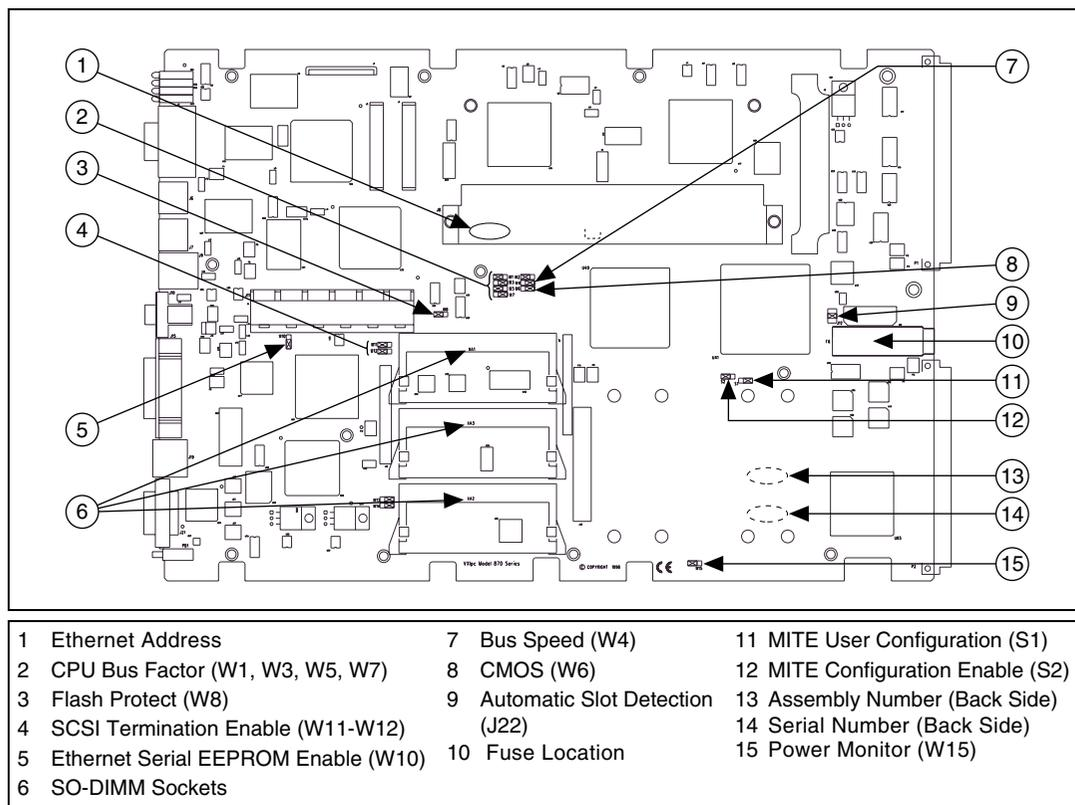

Figure 3-1. VXIpc 870 Series Parts Locator Diagram

Table 3-1 lists the factory-default settings and options for the onboard jumpers and switches.

Table 3-1. VXIpc 870 Series Hardware Default Settings

Jumper	Default Setting	Optional Setting
J12	Enable automatic Slot 0 detection	Force Slot 0; Force Non-Slot 0
S1	MITE user configuration	MITE factory configuration
S2	Enable MITE self-configuration	Disable MITE self-configuration
W1,3,5,7	CPU bus factor	Note: Refer to <i>CPU Bus Factor</i> section later in this chapter.
W4	100 MHz CPU bus speed	66 MHz CPU bus speed
W6	Normal CMOS operation	Clear CMOS
W8	Flash write enable	Flash protection
W10	Enable Ethernet Serial EEPROM configuration	Disable Ethernet Serial EEPROM configuration (uses default power on values)
W11-12	Enable 16-bit SCSI termination	SCSI termination
W15	Voltage monitor only required voltages	Voltage monitor all voltages



Note Please do not adjust any jumpers or switches not listed in Table 3-1 or that are not documented in this manual unless directed by National Instruments. Other configuration jumpers are shown in the event National Instruments Technical Support needs to make adjustments to your settings.

Software Default Settings

In this section, Tables 3-2 through 3-4 contain summaries of default settings for VXIpc T&M Explorer. Because you can also use T&M Explorer

to configure a VXI-MXI-2, for your convenience, Tables 3-5 through 3-7 contain a summary of the software default settings for the VXI-MXI-2.

Table 3-2. VXIpc T&M Explorer Device Tab Default Settings

Editor Field	Default Setting
Logical address	0
Device class	Message based
Size of Servant area	0
Number of handlers	1
Number of interrupters	0

Table 3-3. VXIpc T&M Explorer Shared Memory Tab Default Settings

Editor Field	Default Setting
Memory sharing	A32
Shared RAM size	64 KB (when sharing memory)
Reserved physical memory	64 KB (when sharing memory)
Lower half window byte swapping	Disabled
Upper half window byte swapping	Disabled
Map upper and lower halves at same PCI address	Disabled

Table 3-4. VXIpc T&M Explorer PCI Tab Default Settings

Editor Field	Default Setting
Low-level register access API support	Enabled
User window size	128 MB

VXI-MXI-2

This section summarizes the software default settings for the VXI-MXI-2. This information is included for your convenience in case you have any of these modules in your system.

Table 3-5. VXI-MXI-2 T&M Explorer Device Tab Default Settings

Editor Field	Default Setting
Logical address	Use DIP switch
Address space	A24 *
Requested memory	16 KB *
A24/A32 write posting	Disabled
A16 write posting	Disabled
Interlocked mode	Disabled
* Assumes no DRAM is installed. If DRAM is installed, the Address space should be A32, and Requested memory should match the amount of DRAM. If you install the DRAM yourself, you must manually specify these changes.	

Table 3-6. VXI-MXI-2 T&M Explorer VXI Bus Tab Default Settings

Editor Field	Default Setting
Bus timeout value	125 μ s
Slot 0 configuration	Auto-detect
Auto retry	Disabled
Transfer limit	256
Arbiter type	Priority
Fair requester	Enabled
Arbiter timeout	Enabled
Request level	3

Table 3-7. VXI-MXI-2 T&M Explorer MXI-2 Bus Tab Default Settings

Editor Field	Default Setting
System controller	Auto-detect
Bus timeout value	1 ms
MXI-2 auto retry	Disabled
MXI transfer limit	Unlimited
MXI fair requester	Disabled
Perform parity checking	Enabled
MXI-2 CLK10 signal direction	Switch determines signal direction

Configuring the VXIpc 870 Series

This section describes how to configure the following options on the VXIpc 870 Series:

- VXI Controller/Non-System Controller
- VXIbus CLK10 routing and termination
- Trigger input termination
- MITE EEPROM

Accessing the Hardware Switches

The VXIpc 870 Series is housed in a metal enclosure comprised of a top and bottom cover to improve EMC performance and to provide easy handling. You need to remove the top cover to change many of the switch and jumper settings. You must also remove the top cover to change the amount of DRAM installed on the module.

Remove the top cover by removing the screws that attach it to the module.

VXibus System Controller/Non-System Controller

The VXIpc 870 Series is configured at the factory to automatically detect if it is installed in Slot 0 of a VXibus mainframe. With automatic System Controller slot detection, you can install the module into any VXibus slot.

You can manually configure the VXIpc 870 Series for either System Controller or Non-System Controller operation by defeating the automatic-detection circuitry. Use the three-position jumper J12 to select automatic detection, System Controller, or Non-System Controller operation. Figure 3-2 shows these three settings.



Caution Do not install a device configured for System Controller into another slot without first reconfiguring it to either Non-System Controller or automatic-detection configuration. Neglecting to do this could result in damage to the device, the VXibus backplane, or both.

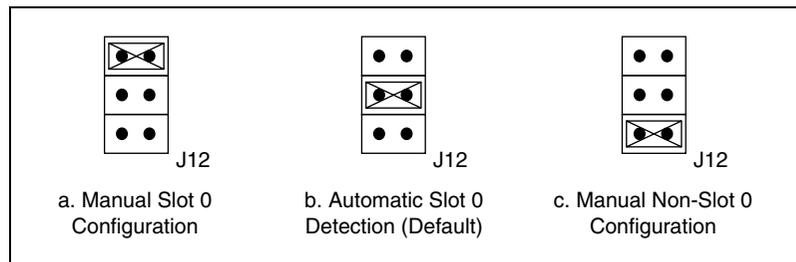

Figure 3-2. System Controller Slot Configuration

When the VXIpc 870 Series is installed in Slot 0 of a VXI system, it becomes the VXibus System Controller. In this role, it has VXibus Data Transfer Bus Arbiter circuitry that accepts bus requests on all four VXibus request levels, prioritizes the requests, and grants the bus to the highest priority requester. As VXibus System Controller, the VXIpc 870 Series also drives the 16 MHz VXibus system clock by an onboard 16 MHz oscillator.

As required by the VXibus specification, the VXIpc 870 Series drives the 10 MHz signal CLK10 on a differential ECL output when installed in Slot 0. When not installed in Slot 0, the VXIpc 870 Series only receives the CLK10 signal.

VXibus CLK10 Routing and Termination

When the VXIpc 870 Series is installed in Slot 0 of your mainframe, it supplies the VXibus CLK10 signal. The VXIpc 870 Series can use two different sources to generate this signal—an onboard oscillator or the external CLK SMB connector. The VXIpc 870 Series can also be configured to drive the external CLK10 SMB from the VXibus CLK10 signal when in Non-Slot 0.

The VXIpc 870 Series has onboard logic that helps configure the VXibus CLK10 routing and termination. You can route the CLK10 signal from the front panel to the backplane or from the backplane to the front panel. You also have the option to add a 50 Ω termination to the signal.

All settings for CLK10 routing and termination are handled through software. Use T&M Explorer to configure these settings.

Trigger Input Termination

You have the option to terminate the external trigger input SMB with 50 Ω to ground to match the driving source, if necessary. Use T&M Explorer to set this option.

MITE EEPROM

The VXIpc 870 Series has an onboard EEPROM, which stores default register values for the VXI circuitry. These values are loaded when you power up the computer. These values read from the EEPROM program the PCI interface and the VXibus registers so that the VXI interface is ready to respond to Resource Manager accesses within the required 5 s of SYSRST* deasserting.

You can disable this power-on self-configuration (POSC) circuit by changing switch S2. Although this makes the VXI circuitry unusable, it is sometimes helpful in debugging address and interrupt conflicts with add-in boards. In general, however, you should leave switch S2 in its factory-default setting. Figure 3-3 shows the possible configurations for S2.

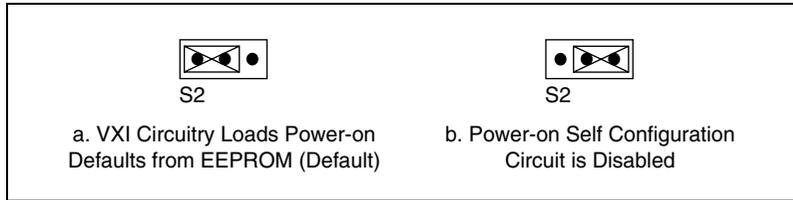

Figure 3-3. Power-on Self Configuration Status

The EEPROM is divided into two halves—one half is factory configured and one half is user configurable. Use switch S1 to control the operation of the EEPROM. The setting of this switch determines whether the VXIpc 870 Series boots off the factory-configured half or the user-modified settings. In its default setting, the VXIpc 870 Series boots off the user-configurable half.

This switch is useful in the event that the user-configured half of the EEPROM becomes corrupted in such a way that the VXIpc 870 Series boots to an unusable state. By altering this switch setting, you can return to the factory configuration and get up and running again. Use the procedure as described in the following section, *How to Fix an Invalid EEPROM Configuration*.

Figure 3-4 shows the configuration settings for EEPROM operation.

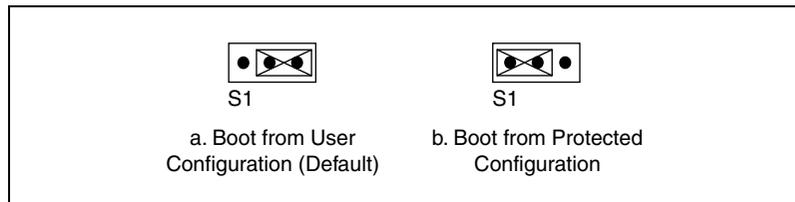

Figure 3-4. EEPROM Configuration

How to Fix an Invalid EEPROM Configuration

Use T&M Explorer under Windows NT/9x to edit the configuration of the VXIpc 870 Series. Some of these settings are stored in files that are read by the NI-VXI software, while other settings are stored directly in the VXIpc 870 Series EEPROM.

Certain EEPROM configurations, including invalid configurations, can lock up your computer while it is booting up. Generally, only the size and location of the memory windows can cause your VXIpc 870 Series to lock up your system. For example, many PCI-based computers will not boot if a

board in its system requests more memory space than the computer can allocate. If you encounter this situation you should reduce the size of the VXIpc 870 Series user window. The EEPROM can become corrupted if the VXIpc 870 Series is shut down while it is updating the EEPROM.

If this situation occurs after you change the configuration, perform the following steps to reconfigure the VXIpc 870 Series:

1. Turn off your computer.



Warning To protect both yourself and the mainframe from electrical hazards, the mainframe should remain off until you are finished changing the settings on the VXIpc 870 Series.

2. Change switch S1 to the position shown in Figure 3-4b to restore the factory configuration.
3. Turn on the computer. The computer should boot this time because the factory-default configuration is being used to initialize the VXIpc 870 Series.
4. Run your software configuration utility to re-adjust the VXIpc 870 Series configuration.
5. After saving the configuration, exit Windows and turn off the computer.
6. Change switch S1 to the default position, as shown in Figure 3-4a.
7. Turn on the computer. If the computer does not boot with this configuration, you will need to repeat these steps, modifying your configuration until a final configuration is reached.

Configuring the PC

This section describes how to configure the following options on the PC:

- SCSI termination
- System CMOS
- CPU bus speed
- CPU bus factor
- Flash Protection
- Ethernet Serial EEPROM
- Voltage Monitor

- NI WatchDOG
- Installing additional memory

This section also explains how to change the main power fuse.

SCSI Termination

The VXIpc 870 Series uses active termination on the SCSI-3 bus. Because the VXIpc 870 Series is always an end device, you should not need to disable the termination; however, for informational purposes Figure 3-5 shows the jumper settings for both enabled and disabled termination.

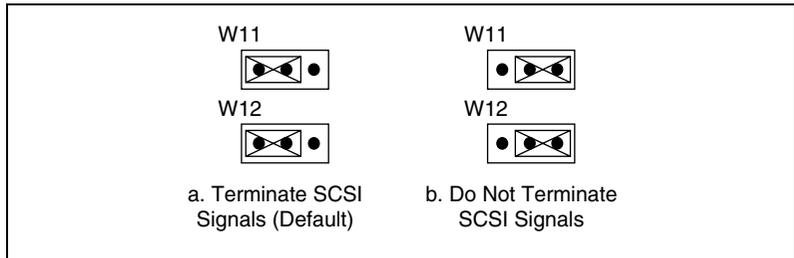

Figure 3-5. SCSI Termination

System CMOS

The VXIpc 870 Series contains a backed-up memory used to store BIOS defaults and configuration information:

To clear the CMOS contents:

1. Place the jumper as shown in Figure 3-6b to short the pins of W6.



Caution Do *not* keep these two pins shorted because the CMOS memory cannot be sustained when the power is turned off in this state.

2. Power-on the VXIpc 870 Series. The screen should briefly appear, and then go black.
3. Power-off the VXIpc 870 Series.

4. Remove the jumper as shown in Figure 3-6a to restore normal operation.

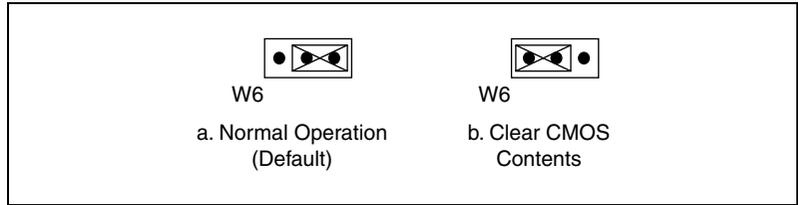

Figure 3-6. System CMOS

CPU Bus Speed

The VXIpc 870 Series supports CPU bus speeds at 66 MHz and 100 MHz. Under most circumstances 100 MHz delivers the best performance. However, if you want to use a lower bus speed, W4 overrides the 100 MHz setting as shown in Figure 3-7.

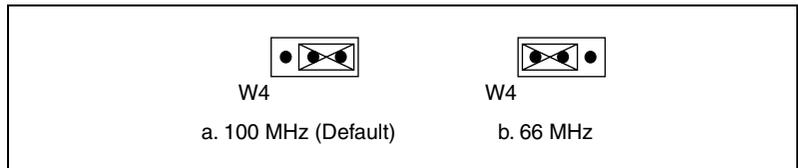

Figure 3-7. CPU Bus Speed Configuration

CPU Bus Factor

All Pentium II CPUs are supported as of the release date of this document. The jumper settings in Figure 3-8 are provided to allow the user to upgrade as newer CPUs enter the market. Contact National Instruments for jumper settings as new CPUs are released.

	 W1	 W1	 W1	 W1	 W1	 W1
	 W3	 W3	 W3	 W3	 W3	 W3
	 W5	 W5	 W5	 W5	 W5	 W5
	 W7	 W7	 W7	 W7	 W7	 W7
CPU Speed	300 MHz	400 MHz	500 MHz	250 MHz	350 MHz	450 MHz
Bus Factor	x3	x4	x5	x2.5	x3.5	x4.5 (default)

Figure 3-8. CPU Bus Factor Jumper Settings

Flash Protection

The VXIpc 870 Series uses a standard 2M bit flash with write protection. Under normal use, this jumper should not be changed. Figure 3-9 shows default and disabled settings.

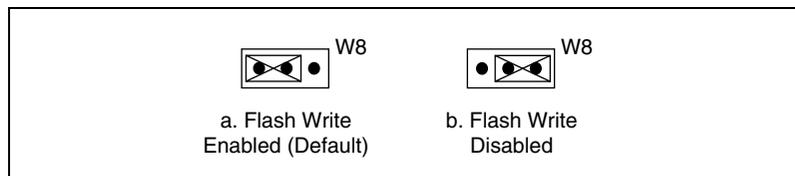

Figure 3-9. Flash Protection Settings

Ethernet Serial EEPROM

A serial EEPROM loads the Ethernet power-on settings. Under normal use, this jumper should not be changed. Figure 3-10 shows default and disabled settings.

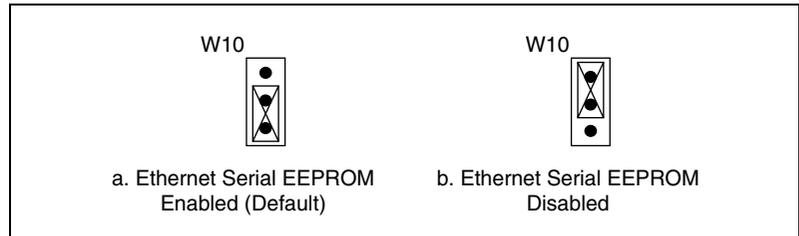

Figure 3-10. Ethernet Serial EEPROM Settings

Voltage Monitor

You can monitor all backplane voltages or only those required to boot on the VXIpc 870 Series with built-in voltage-monitor circuitry as shown in Figure 3-11.

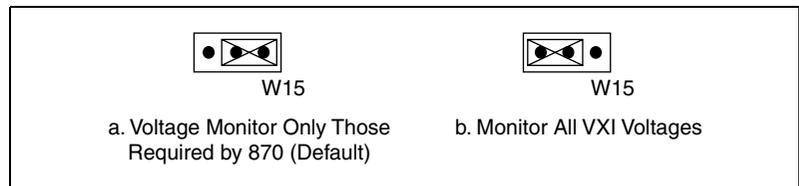

Figure 3-11. Voltage Monitor Settings

NI WatchDOG

The NI WatchDOG is an onboard, general-purpose counter/timer. You can use it to monitor running applications and reset the embedded controller or assert a signal should the system lock up. All WatchDOG timer features are configured through T&M Explorer. See the *NI WatchDOG* section in Chapter 5, *Functional Overview*, for more information.

Installing Additional Memory

The VXIpc 870 Series uses 144 pin 100 MHz SDRAM and supports 16, 32, 64, and 128 MB SO-DIMMs for a total of 384 MB maximum. As DRAM technology improves, the maximum amount of RAM supported may increase.

To add RAM to the VXIpc 870 Series, do the following.

1. Remove the unit from the VXI mainframe.
2. Remove the screws that hold the cover in place and remove the cover.
3. Add SO-DIMM modules to the empty SO-DIMM sockets.

National Instruments recommends the following types of SO-DIMMs for use with the VXIpc 870 Series controller (SDRAM):

32 MB: 4 MB × 64 SO-DIMMs—10 ns, 1.05 in. max.

64 MB: 8 MB × 64 SO-DIMMs—10 ns, 1.05 in. max.

128 MB: 16 MB × 64 SO-DIMMs—10 ns, 1.05 in. max.



Note National Instruments has tested and verified that the SO-DIMMs we sell work with the VXIpc 870 Series. We recommend you purchase your SO-DIMM modules from National Instruments. Other off-the-shelf SO-DIMM modules are not guaranteed to work properly.

Changing the Main Power Fuse

The VXIpc 870 Series is equipped with a user-replaceable fuse on the main power, +5 V from the VXIbus. All other voltages are fused with a resettable-style circuit breaker. The resettable-style circuit breakers do not require user intervention. When a short circuit condition is removed, they automatically reset themselves.

The main power, +5 V, is too high of a current for resettable fuse technology, so your kit includes a replaceable fuse of type 3AG, 15A, Slowblow.

You can replace this fuse without having to remove the cover. The fuse is accessible through the rear of the unit as shown in Figure 3-12.

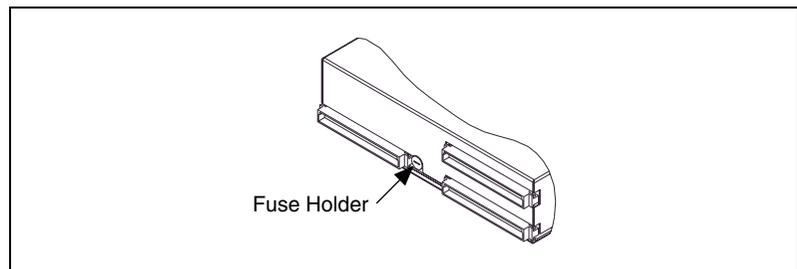

Figure 3-12. Main Power Fuse Replacement

To replace a fuse, do the following:

1. Turn off the VXI mainframe and remove the VXIpc 870 Series module.
2. Using a small flathead screwdriver, turn the fuse holder counter-clockwise until the fuse and holder start to come out of the unit.
3. Replace the fuse with the same type fuse.



Caution Do *not* replace with a higher-rated fuse. This could cause damage to the VXIpc 870, the VXI mainframe, or both.

4. Insert the fuse and hold back into the fuse housing, pushing it all the way in.
5. Screw the fuse holder clockwise until the fuse holder is flush with the fuse housing.
6. Re-install the VXIpc 870 and apply power.



Note If the fuse continues to blow, contact National Instruments for assistance.

Developing Your Application

This chapter discusses the software utilities you can use to start developing applications that use the NI-VXI/VISA driver.

After verifying your system configuration, you can begin to develop your VXI/VME or VISA application software. Be sure to check the `README.txt` file for the latest application development notes and changes.

Your software includes several utilities to assist you in your system development. These include T&M Explorer, Resman, NI Spy, VISAIC, and VIC. You can also access several examples to learn how to use NI-VISA or NI-VXI for certain tasks. Each of these components assists you with one of four steps of development: configuration, device interaction, programming, and debugging.

You can access these utilities through the Windows **Start** menu. Open either the National Instruments VXI or VXIpn program group and select the utility you want to use.

Configuration

The configuration utilities in your kit are T&M Explorer and Resman. Resman is the application that performs VXI Resource Manager functions as described in the VXIbus specification. Its most important functions include configuring all VXI devices on the VXI backplane for operation and allocating memory for devices that request it.



Note Because power cycling resets all devices, run Resman to reconfigure them every time chassis power is cycled.

Resman must be run on any system that contains VXI devices (including systems containing VXI-MXI-2 or VME-MXI-2 mainframe extender devices). Because VME devices normally do not have configuration registers as defined in the VXIbus specification, the Resource Manager is unable to detect VME devices. Because of this, when using systems containing a mixture of VME devices and VXI devices, you need to manually add your VME devices in T&M Explorer

using the **Add VME Device Wizard** to reserve system resources when the Resource Manager runs.

Systems consisting of only a VMEpc 870 Series controller, a VME chassis, and VME boards do *not* need to run Resman when using NI-VXI software even though the devices do not appear in the T&M Explorer connection tree. However, you would not be able to use VISA without manually adding the VME devices to the system by using T&M Explorer as described above and then running Resman. This is because NI-VISA uses the Resource Manager to create instrument sessions for VXI/VME device communication. If this is not an issue for you, you can skip Resman.

T&M Explorer presents a graphical display of your entire test and measurement system to help you configure various components. When you launch T&M Explorer, you see all your VXI, GPIB, GPIB-VXI, and serial devices on the screen. You can add devices that cannot be detected dynamically by T&M Explorer through the **Add Device Wizard** in the **Edit** menu. Such devices include VME devices, certain GPIB devices, and serial ports. You can view the properties (such as logical address, address space used, primary address, and so on) of each device by right-clicking on the device in the tree. When you view the properties of most National Instruments devices, you can configure the hardware settings directly in the property pages.

T&M Explorer and Resman are designed to work together. You can run the Resource Manager through T&M Explorer by either clicking on the **Run Resman** button on the toolbar, or selecting **VXI Resource Manager** from the **Tools** menu. From the **Options** dialog in the **Tools** menu, you can also configure T&M Explorer to run Resman automatically when the computer boots up. Resman reports all errors that it finds in your system to T&M Explorer. When you view your system through T&M Explorer, you can easily spot any errors in your system that Resman found.

You can find more information about T&M Explorer by using its online help. From T&M Explorer, open the **Help** menu and select **Help Topics**.

Device Interaction

After Resman has detected and configured all VXI devices, you can view specific information on each device in your system by using the T&M Explorer utility. This utility includes a **System View**, which contains a description for each device, including each VXI device's logical address.

You can interact with your VXI devices by using the VIC or VISAIC utility (VIC for NI-VXI or VISAIC for NI-VISA). You can use these utilities to interactively control your devices without having to use a conventional programming language, LabVIEW, or LabWindows/CVI.



Note You can launch VIC or VISAIC from the Tools menu in T&M Explorer.

Try the following in VIC:

In the **Command** entry field, type `help vxiiin`.

This help file shows you the syntax for this command, which reads VME address space. The first argument is the access parameters for selecting the address space, byte order, and so on. The second is the VME address to read, and the third is the width of the data to read.

Type:

```
vxiiin 1,0xC000,2
```

The **History** window shows the result of the command execution, such as:

```
Return Status (0): SUCCESS.  
value = 0x9ff6
```

If the value ends with `ff6`, you have successfully read the National Instruments manufacturer ID from the VXIpc 870 Series ID register. Because this is the first configuration register present for all VXI devices, the VXI device at Logical Address 0 has its manufacturer ID register located at A16 address `0xC000`—the beginning of the VXI configuration space.

You may now want to read the registers from other devices in your system using the command `vxiiin`. Try reading a register from each of the devices listed in the **Address Map View** of T&M Explorer. In this way, you can verify that your VXIpc 870 Series controller can access each of the devices in your system successfully.

Alternatively, you can use VISAIC to interact with your devices. VISAIC lists the available devices, similar to what T&M Explorer displays. By double-clicking on a given device, you can open a VISA session and access the device through it. For more information regarding VISAIC, use the right-click help available from all panels.

Programming with VXI

National Instruments provides two different programming interfaces for accessing your instruments: NI-VISA and NI-VXI. NI-VISA is the National Instruments implementation of the VISA API as defined by the *VXIplug&play* standard. It is very useful when you have different types of instruments in your system (such as VXI, VME, GPIB, and Serial devices) because the NI-VISA functions have the same interface.

NI-VXI is the National Instruments proprietary interface for programming VXI/VME instruments. Both NI-VXI and NI-VISA grant you register-level access of VXI/VME instruments as well as messaging capability to message-based devices. With either interface you can service asynchronous events, such as triggers and interrupts, and also assert them.

The best way to learn how to program with NI-VXI or NI-VISA is by reviewing the example programs included in your software. In the `Examples` directory you will find examples for many different types of applications. If you are just getting started, you should first learn how to access registers with high-level calls and send messages with word serial functions. The NI-VISA examples of these tasks are called `VISAhigh.c` and `VISAws.c`. The NI-VXI examples are called `VXIhigh.c` and `VXIws.c`. You should use the other examples as you try more advanced techniques. Consult the *NI-VISA User Manual* or the *NI-VXI User Manual* for additional information on these topics.



Note The NI-VXI User Manual resides in the `NIVXI\manuals` directory, and the NI-VISA User Manual is in the `VXIpn\os\NIvisa>manuals` directory, where `os` would be either `win95` or `winNT`. Use the Acrobat Reader program to open and navigate through the manuals.

Table 4-1 summarizes the topics addressed by the example programs.

Table 4-1. NI-VXI/VISA Examples

Coverage	NI-VISA Example	NI-VXI Example
Message-Based Access	<code>VISAws.c</code>	<code>VXIws.c</code>
High-Level Register Access	<code>VISAhigh.c</code>	<code>VXIhigh.c</code>
Low-Level Register Access	<code>VISAlow.c</code>	<code>VXIlow.c</code>
Sharing Memory	<code>VISAmem.c</code>	<code>VXImem.c</code>

Table 4-1. NI-VXI/VISA Examples (Continued)

Coverage	NI-VISA Example	NI-VXI Example
Interrupt Handling	VISAint.c	VXIint.c
Trigger Handling	VISAtrig.c	VXItrig.c



Note T&M Explorer includes special settings that you must use for low-level functions and memory sharing. Consult the T&M Explorer online help for information on setting these up.

Notes about VME Support

To use VME devices in your system, configure NI-VXI to see these devices by using the **Add Device Wizard** in T&M Explorer. VME devices with two blocks of memory in the same address space require two entries. You can also specify which interrupt levels the device uses. VXI and VME devices cannot share interrupt levels. You can then access the VME device from NI-VXI or NI-VISA just as you would a register-based VXI device, by specifying the address space and the offset from the base at which you have configured it. NI-VISA support for VME devices includes the register access operations (both high-level and low-level) and the block move operations, as well as the ability to receive interrupts.

Compiler Symbols for NI-VXI

You may need to define some symbols so that the NI-VXI library can work properly with your program.



Note Skip this section if you are programming with NI-VISA only. NI-VISA does not use these symbols.

You can define the symbols using `#define` statements in the source code or you can use either the `/D` or the `-D` option in your compiler (both the Microsoft and Borland compilers support the `/D` and `-D` options). If you use `#define` statements, you must define the symbols before including the NI-VXI header file `nivxi.h`. If you use the makefiles to compile the sample program, the makefile already defines the necessary symbols.

The `VXINT` symbol is required. You must define it when using the Microsoft C or Borland C compiler. `VXINT` designates the application as a Windows NT/98 application.



Note LabWindows/CVI automatically defines the correct symbol. You do not need to define `VXINT` when using LabWindows/CVI.

Debugging

NI Spy, VISAIC, and VIC are useful utilities that can aid in identifying the causes of problems in your application.

NI Spy tracks the calls your application makes to National Instruments T&M drivers including NI-VXI, NI-VISA, and NI-488.2. NI-488.2 users may notice that NI Spy is very similar to GPIB Spy. It highlights functions that return errors, so you can quickly spot which functions failed during your development. NI Spy can log the calls your program makes to these drivers so you can check them for errors at your convenience.

You can also control your instruments interactively using VISAIC and VIC. You can use VISAIC to control and communicate with your instruments with NI-VISA without having to write a program. VIC gives you a similar environment that uses NI-VXI. These utilities are an excellent platform for quickly testing instruments and learning how to communicate with them.

Refer to the online help for instructions on how to use VIC or VISAIC and to learn about their features. In VIC, click on the **?** button (next to the **Go** button) to get help for that page, or you can type `help`. You can also right-click on a component on the screen to access **What's This** help. In VISAIC, you can right-click to reach **What's This** help and function help.

Functional Overview

This chapter contains functional descriptions of each major logic block on the VXIpc 870 Series.

VXIpc 870 Series Functional Description

The VXIpc 870 Series is a VXIbus embedded controller in a C-size form factor. It includes many high-performance peripherals that normally require add-in cards on desktop PCs. In addition, it has a VXIbus interface that is controlled from the PCI local bus, providing extremely high performance and reliability.

Figure 5-1 is a functional block diagram of the VXIpc 870 Series. Following the diagram is a description of each logic block shown.

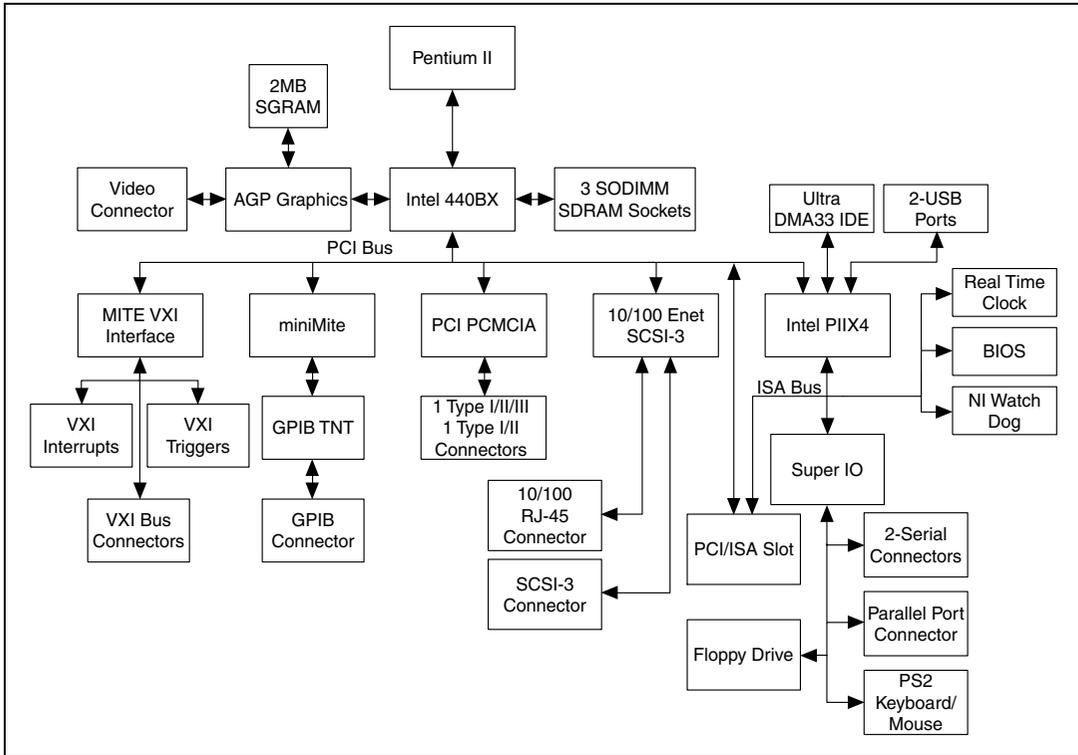

Figure 5-1. VXIpc 870 Series Block Diagram

Processor

The VXIpc 870 Series controllers are based on the Intel Pentium II, Slot 1 architecture. The CPU connects to the motherboard through the 100 MHz GTL+ bus. Because of this modular design, you can easily upgrade your VXIpc 870 Series controller with a new CPU. As your application needs expand or change in the future, you can save money by changing the CPU as compared to purchasing a brand new controller. The VXIpc 870 Series controllers are based on Pentium II technology, and deliver 512 KB of level two cache.

Chip Set and SDRAM

The VXIpc 870 Series uses the latest in Intel Chip Set technology—the Intel 440BX Chip Set. The 440BX connects the Pentium II to the AGP port, PCI bus, and the SDRAM. The 440BX uses a 100 MHz bus for the CPU and SDRAM connections to give the highest performance possible. The VXIpc 870 Series has three SO-DIMM sockets that can support a

maximum of 192 MB of main memory although as DRAM technology improves, the maximum amount of RAM supported may increase. The 440BX also connects to SVGA through the AGP port. The PCI bus is then responsible for connecting the rest of the system.

AGP Graphics

The VXIpc 870 Series uses a S3 VirgeMX AGP-based graphics controller to connect to SVGA. The AGP graphics controller is coupled to 2 MB of high-speed 64-bit SGRAM. Using the AGP port for graphics delivers a higher-speed connection between the CPU and graphics controller, off-loading traffic from the PCI bus. A few of the resolutions you can use include:

- 640 × 460 16M colors
- 800 × 600 16M colors
- 1024 × 768 64K colors
- 1280 × 1024 256 colors
- 1600 × 1200 256 colors

10/100 Ethernet and SCSI-3

The Ethernet and SCSI on the VXIpc 870 Series use a Symbios 53C885 dual-function PCI device to connect to 10/100Base Ethernet and Ultra Wide SCSI-3. The Ethernet function has auto negotiation to connect to 10BaseT and 100BaseTX automatically at 10 Mbits/s and 100 Mbits/s. The Ultra Wide SCSI-3 function is compatible with SCSI-1, SCSI-2, and SCSI-3. It supports 16-bit Ultra Wide SCSI transfers up to 40 Mbytes/s and 8-bit Ultra SCSI synchronous transfers at 20 Mbytes/s.

PC CARD Expansion

You can add third-party peripheral cards, such as additional serial ports, through one of the two PC CARD slots on the front panel. The VXIpc 870 Series can accommodate one Type I/II/III PC CARD and one Type I/II PC CARD simultaneously. The VXIpc 870 Series uses the Cirrus 6730 PCI-PC CARD bridge.

PCI or ISA Expansion

The VXIpc-872 motherboard can have an expansion slot for either one full-length PCI expansion card or one 16-bit XT-height ISA bus card. You can insert either one PCI or one ISA card, but not both at the same time. Refer to Appendix D, *Modifying and Installing I/O Expansion Boards*, for more information on using this expansion slot. The VXIpc-871 module does not have this expansion slot.

IEEE 488.2/HS488 Interface

The VXIpc 870 Series uses the miniMITE and TNT4882 ASIC (compatible with the National Instruments PCI-GPIB) to give full GPIB control of external instruments via a front-panel connector. GPIB control capability is fully IEEE 488.2 compatible. The GPIB interface on the VXIpc 870 Series is fully compatible with the National Instruments industry-standard NI-488.2 driver for a variety of operating systems. Any software using NI-488.2 will run on the VXIpc 870 Series. Using the high-speed HS488 protocol, the VXIpc 870 Series can transfer data at up to 8 Mbytes/s.

PIIX4

The Intel PIIX4 is the bridge between the PCI bus and the ISA bus. It features the basic PC counter/timers, interrupt controller, and DMA controllers. It also connects to the USB port and to an Ultra DMA 33 IDE interface. The Ultra DMA 33 interface is the fastest means to connect an industry-standard IDE drive to the system.

Super IO

The Super IO block is the interface to standard PC functions, serial ports, parallel port, floppy drive, and PS2 keyboard and mouse. The serial ports can communicate at up to 460.8 kbits/s, and the parallel port supports all modes of EPP and ECP standards.

NI WatchDOG

The NI WatchDOG is a general-purpose counter/timer that you can use to monitor running applications and reset the embedded controller or assert a signal should the system lock up. On a WatchDOG timeout, the WatchDOG can assert any of the following:

- Reset
- VXI trigger line

- VXI interrupt
- For more advanced features, please contact National Instruments

The NI-VXI/VISA software makes it easy to use NI WatchDOG. The NI WatchDOG has a 32 kHz reference clock to clock an 8-bit prescaler that then clocks an 8-bit counter to accommodate timeouts up to 2 seconds.

Real-Time Clock

The VXIpc 870 Series uses a standard Y2K compliant real-time clock with a user-replaceable battery for backing up the CMOS setting.

BIOS

The VXIpc 870 Series uses a 2 Mb flash device for BIOS code. The BIOS code is based on the AWARD Modular BIOS. The BIOS code incorporates the VIDEO BIOS and SCSI BIOS in one device. The BIOS is user upgradable through a flash update utility.

Programmable Reset Circuitry

The programmable reset circuitry on the VXIpc 870 Series simplifies software development. You can program the circuitry to reset the PC based on VXI SYSRESET or reset the VXI bus only using NI-VXI.

VXI Voltage Monitor Circuitry

The VXIpc 870 Series has onboard logic to check all VXI backplane voltages. The **PWROK** status LED indicates when all voltages are present. This LED can give you a quick indication that something is wrong with the system. The voltage monitor can be configured to monitor all VXI power on just the voltages needed by the VXIpc 870 Series.

Fused Power Protection

The VXIpc 870 Series uses resettable fuses on all voltages except +5 V. The +5 V power is a user-replaceable fuse accessible through the rear of the unit.

VXI Bus

VXI Addressing

The VXIpc 870 Series computers feature the MITE and MANTIS custom ASICs for accessing the VXI backplane resources. To access VXI memory or VXI devices, the VXIpc 870 Series uses the multiple-windowing scheme of the MITE, which makes it possible to access all of VXI address space. You can configure the VXI address windows to view specific areas of VXI memory, or you can use NI-VXI/VISA to do this automatically. The MITE exports a total of eight independent VXI address windows. The NI-VXI/VISA software driver uses three separate windows—one for VXI configuration space (A16), one for memory space (A24, A32), and one for internal use. The remaining five windows are completely user configurable. You can use one or all five windows; you can also configure the size and location of the windows. This multiple-windowing scheme alleviates the performance penalty related to the context switching of one window that you would constantly have to move between the different address spaces.

DMA Transfers to and from VXI

The VXIpc 870 Series can perform block-mode transfers using one of the two on-chip DMA controllers on the MITE. Controlling external VXI devices often consumes valuable CPU time because the microprocessor typically shoulders the burden of transferring data to and from devices. However, MITE-based VXI controllers, such as the VXIpc 870 Series, free up CPU processing time by moving the burden of block data transfers to one of the DMA controllers integrated in the MITE. Instead of the computer microprocessor transferring the data and/or commands, the NI-VXI/VISA software uses the MITE ASIC to execute the block data transfers. While the MITE transfers the data, the processor can perform application-specific tasks, such as data presentation and analysis.

VXI Slot 0 Functionality

The VXIpc 870 Series computers have full VXI Slot 0 capability, including a MODID register and a CLK10 source, as required by the VXIbus specification. You can also install the VXIpc 870 Series in another slot and use it in Non-Slot 0 mode. No matter what your configuration needs, the VXIpc 870 Series can automatically detect whether it is inserted into Slot 0 and automatically enable or disable the Slot 0 onboard circuitry without switches and jumpers.

External VXI CLK10 Synchronization

The VXIpc 870 Series computers have an SMB connector on the front panel for an external clock. Onboard programmable logic can configure the VXIpc 870 Series to drive its 10 MHz VXI CLK10 signal to this connector as an output or to use this connector as an input for the 10 MHz VXI CLK10 signal. In this fashion, you can configure multiple mainframes to operate off a single 10 MHz system clock. All CLK10 routing features are controllable through software.

VXI Trigger Lines

The VXIpc 870 Series gives programmers full hardware and software control over the VXI trigger lines. The VXIpc 870 Series has two SMB trigger I/O connectors on its front panel for routing any of the TTL trigger lines between the backplane and external devices. The VXI trigger interface is based on the advanced MANTIS ASIC developed by National Instruments. The MANTIS provides the complete VXIpc 870 Series VXI interface to the outer rows of the P2 backplane connector in a single chip. The VXIpc 870 Series can respond to all VXI-defined protocols on all P2 TTL and ECL trigger lines at the same time. The MANTIS features an internal cross-matrix switching system for routing between lines as well as to and from the front panel and onboard clocks. An internal counter gives sophisticated counting of events and interrupting on trigger edges and pulses, as well as generating pulse trains, variable length pulses, and pulse stretching.

VXI Interrupts

The VXIpc 870 Series can function as an interrupter and an interrupt handler for any or all of the VXIbus interrupt lines in a VXI mainframe. The VXIpc 870 Series works with both Release on Acknowledge (ROAK) and Release on Register Access (RORA) devices. All interrupts are routed to the microprocessor. The VXIpc 870 Series can also detect other VXIbus conditions, including assertion of ACFAIL, SYSFAIL, and BERR.

BIOS

This chapter contains information on the BIOS (Basic Input Output System), the low-level interface between the hardware and PC software that configures and tests your hardware at boot up. The BIOS features an easy-to-use graphical user interface you use to configure system aspects according to your needs.

Entering BIOS Setup

To enter the BIOS setup program, perform the following steps:

1. Turn on or reboot the system. A screen appears with a series of diagnostic checks.
2. When **Hit if you want to run SETUP** appears, press the key to enter the BIOS setup program.
3. Choose options with the keyboard. Modify the settings to reflect system options.

Default BIOS Setup Settings

To restore the default settings while inside the BIOS setup program, select either **FAILSAFE Defaults** or **OPTIMAL Defaults**.

Select the Optimal settings if you want to get maximum performance from the VXIpc 870 Series. Fail Safe settings are for debugging purposes.

Specifications

This appendix lists the specifications for the VXIpc 870 Series embedded computer.

Requirements

VXIbus configuration space.....	64 KB
A24 or A32 space.....	programmable
Minimum	16 KB

Environmental

Temperature

Operating	0 to 50 °C
Storage	-20 to 70 °C

Relative humidity

Operating	10 to 90% noncondensing
Storage	5 to 95% noncondensing

EMI FCC Class A verified, EC verified

Random vibration

Operational.....	5 to 500 Hz, 0.3 g _{RMS} , 3 axes
Non-operational	5 to 500 Hz, 2.4 g _{RMS} , 3 axes

Functional shock MIL-T-28800E Class 3
 (per Section 4.5.5.4.1)
 Half-sine shock pulse
 (11 ms duration, 30 g peak,
 3 shocks per face).
 Also meets IEC standard
 60068-2-27.

Power Requirement

+5 V is fused with a user-replaceable glass fuse, type 3AG, 15A, Slowblow. All other voltages use a resettable-type circuit protector that requires no replacement by the user.

+5 V

Typical.....8 A
Maximum15 A

-5.2 V

Typical.....224.5 mA
Maximum2 A

-2 V

Typical.....67.2 mA
Maximum2 A

+12 V

Typical.....102.6 mA
Maximum2 A

-12 V

Typical.....2.43 mA
Maximum2 A

+24 V

Typical.....1 mA

-24 V

Typical.....1 mA

Physical

Dimensions

Fully enclosed, shielded VXI C-size module
233.35 by 340 mm (9.187 by 13.386 in.)

Weight

With 64 MB DRAM Installed2.5 Kg (5.51 lb.)

Slot requirements.....Two VXI C-size slots

Compatibility	Fully compatible with VXI specification
VXI keying class	Class 1 TTL
MTBF	TBD

VMEbus Capability Codes

A32, A24, A16 (master)	VMEbus master A32, A24, and A16 addressing
A32, A24, A16 (slave)	VMEbus slave A32, A24, and A16 addressing
D64, D32, D16, D08(E0) (master)	VMEbus master D64, D32, D16, and D08 data sizes
D64, D32, D16, D08(E0) (slave)	VMEbus slave D64, D32, D16, and D08 data sizes
BLT, MBLT (master)	VMEbus master block and D64 transfers
BLT, MBLT (slave)	VMEbus slave block and D64 transfers
RMW (master)	VMEbus master read/modify/write transfers
RMW (slave)	VMEbus slave read/modify/write transfers
RETRY (master)	VMEbus master retry support
RETRY (slave)	VMEbus slave retry support
FSD	First slot detector
SCON	VMEbus System Controller (Automatic Detection)

PRI, RRS

Prioritized or Round Robin Select arbiter

ROR, RWD, FAIR

Release on Request, Release When Done, and FAIR bus requester

IH(7–1)

Interrupt handler for levels 7–1

I(7–1)

Interrupt requester for levels 7–1

D32, D16, D08(O) (Interrupt Handler)

VMEbus D32, D16, D08(O) interrupt handler

D32, D16, D08(O) (Interrupter)

VMEbus D32, D16, D08(O) interrupter

ROAK, RORA

Release on Acknowledge or Register Access interrupter

BTO(x)

VMEbus bus timer (programmable limit)

LOCK

Can lock the VMEbus for indivisible transfers

LED Indicators

This appendix describes how to read the LEDs on the front panel to interpret the status of the VXIpc 870 Series.

VXIbus Interface Status LEDs

The VXIbus interface status LEDs are located at the top of the module and include four LEDs: **FAIL**, **SYSF**, **ONLINE**, and **PWROK**. They indicate the various stages of initialization that occur as the VXIpc 870 Series boots. The following paragraphs describe each LED.

SYSF LED

The **SYSF** LED is lit when the VXIbus SYSFAIL signal is asserted. It does not necessarily indicate that the VXIpc 870 Series is asserting SYSFAIL, only that there is a device in the system asserting SYSFAIL.

FAIL LED

The **FAIL** LED is lit when the VXIpc 870 Series is driving the SYSFAIL signal. The VXIpc 870 Series asserts SYSFAIL when the PASSED bit in its VXIbus status register is clear. The PASSED bit is set by the power-on self configuration circuitry (POSC) when it has completed initializing the VXIbus interface.

ONLINE LED

The **ONLINE** LED is lit when the Resource Manager has successfully completed and the VXIbus interface is ready for application programs.

PWROK LED

The **PWROK** LED is lit when all the various voltages on the VXIbus backplane are present and within the tolerance range of the onboard detection circuitry. These voltages are monitored behind short circuit protection devices. If the **PWROK** LED is not lit, it could indicate either that a fuse is blown or one of the VXIbus power supplies is not working.

LEDs and System Startup Cycle

Table B-1 shows a system startup cycle and possible points of failure, up to and including the state in which the **ONLINE** LED is asserted.

Table B-1. LEDs and System Startup Status

Step	LEDs Lit	Status	Possible Problem if VXIpc 870 Fails
1	None	Machine just turned on.	The VXIpc 870 Series is not receiving power or a fuse is blown.
2	PWROK	Machine just turned on.	The VXIpc 870 Series is now starting to boot. All voltages are present.
3	PWROK, FAIL, SYSF	Now asserting FAIL because VXIbus interface has not been initialized yet.	Power-on self configuration (POSC) cannot execute because of problems with system reset or because the POSCEN switch is incorrectly configured.
4	PWROK	POSC cycles are complete. VXI port is ready to respond to Resource Manager inquiries.	POSC completed successfully; however, the Resource Manager either hung or was not executed.
5	PWROK, Online	Resource Manager has been executed, indicating that the VXI software can now communicate with the VXIbus circuitry.	Resource Manager interface initialized successfully.

If either the **SYSF** or **FAIL** LED remains lit, perform the following steps:

1. Power off the mainframe.
2. Remove all other modules from the mainframe.
3. Make sure that the VXIpc 870 Series switch and jumper settings are correct.
4. Make sure that the VXIpc 870 Series is seated properly in the mainframe.
5. Power on the mainframe and observe whether the **SYSF** and **FAIL** LEDs become unlit some time before the operating system boots.

Board Access LEDs

The board access LEDs—**ACC**, **DRV**, and **SCSI**—indicate when board resources have been accessed. The following paragraphs describe these LEDs.

ACC LED

When lit, the **ACC** LED indicates that the VXIpc 870 Series MODID line is asserted or that another VXIbus master is accessing VXIbus shared registers or shared memory.

DRV LED

The **DRV** LED light indicates that an access to the internal hard disk drive or the CD-ROM on the 871 is occurring.

SCSI LED

The **SCSI** LED light indicates that an access to an external hard disk drive is occurring.

Ethernet LEDs

The Ethernet LEDs (**RX/TX**, **LNK**, and **100B-T**) indicate the status of the Ethernet interface on the VXIpc 870 Series.

RX/TX LED

The **RX/TX** LED lights when the Ethernet interface is receiving or transmitting a packet.

LNK LED

The **LNK** LED indicates link status—in this case, that the controller is connected to a valid Ethernet port.

100B-T

The **100B-T** LED indicates that the current Ethernet connection is at 100 Mbits/s when lit.



Front Panel and Connectors

This appendix describes the front panel and connectors on the VXIpc 870 Series. This material contains the information relevant to *VXIplug&play* Specification VPP-8, *VXI Module/Mainframe to Receiver Interconnection*.



Note The illustrations in this appendix show the mating face of the connectors. An asterisk (*) after a signal name indicates that the signal is active low.

The VXIpc 870 Series has the following front panel connectors:

- Two RS-232 Serial
- Extended Capabilities Parallel (ECP)
- SVGA Controller
- IEEE 488.2
- 10/100 Ethernet
- UW-SCSI
- External Clock
- Trigger Output
- Trigger Input
- Audio Output
- PS/2-Style Keyboard
- PS/2-Style Mouse
- Two USB

This appendix also describes the VXIbus connector on the VXIpc 870 Series, which connects to the backplane of the VXIbus mainframe.

Front Panel

Figure C-1 shows the front panel layout of the VXIpc-871, Figure C-2 shows the layout of the VXIpc-872, and Figures C-3 and C-4 show the layouts of the VXIpc-873 with nonremovable and removable flash drives, respectively. The drawings show dimensions relevant to key elements on the front panel. Dimensions are shown in inches and millimeters, with millimeter dimensions in square brackets. The front panel thickness for all models in the VXIpc 870 Series is 2.49 mm (0.098 in.).

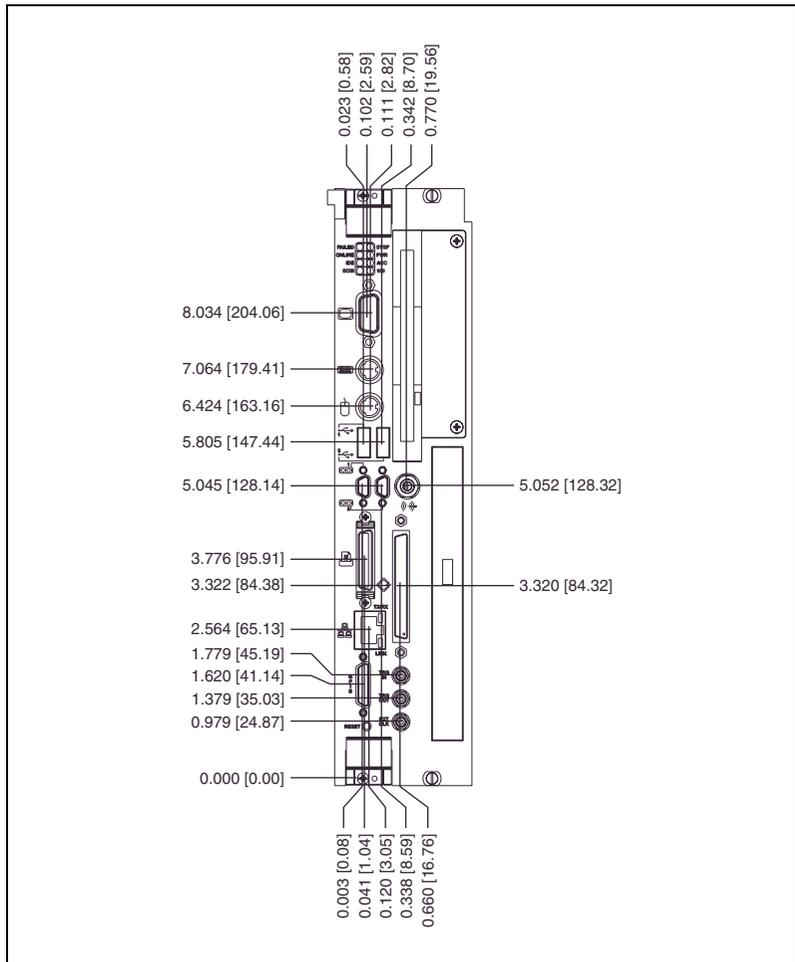

Figure C-1. VXIpc-871 Front Panel Layout and Dimensions

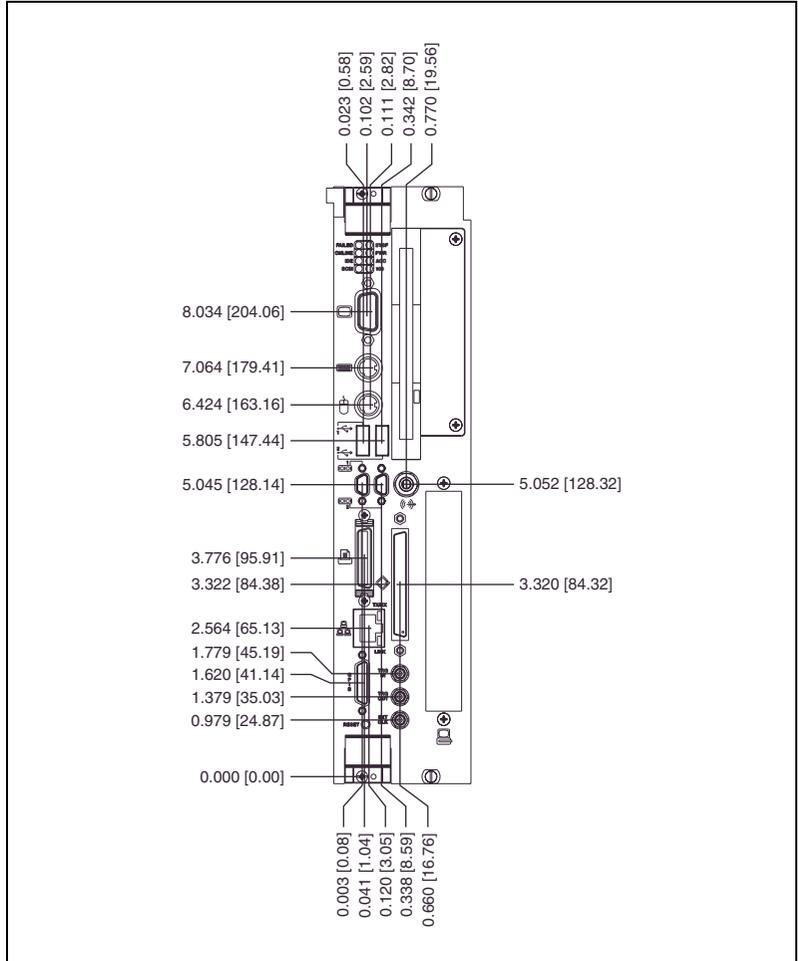

Figure C-2. VXIpc-872 Front Panel Layout and Dimensions

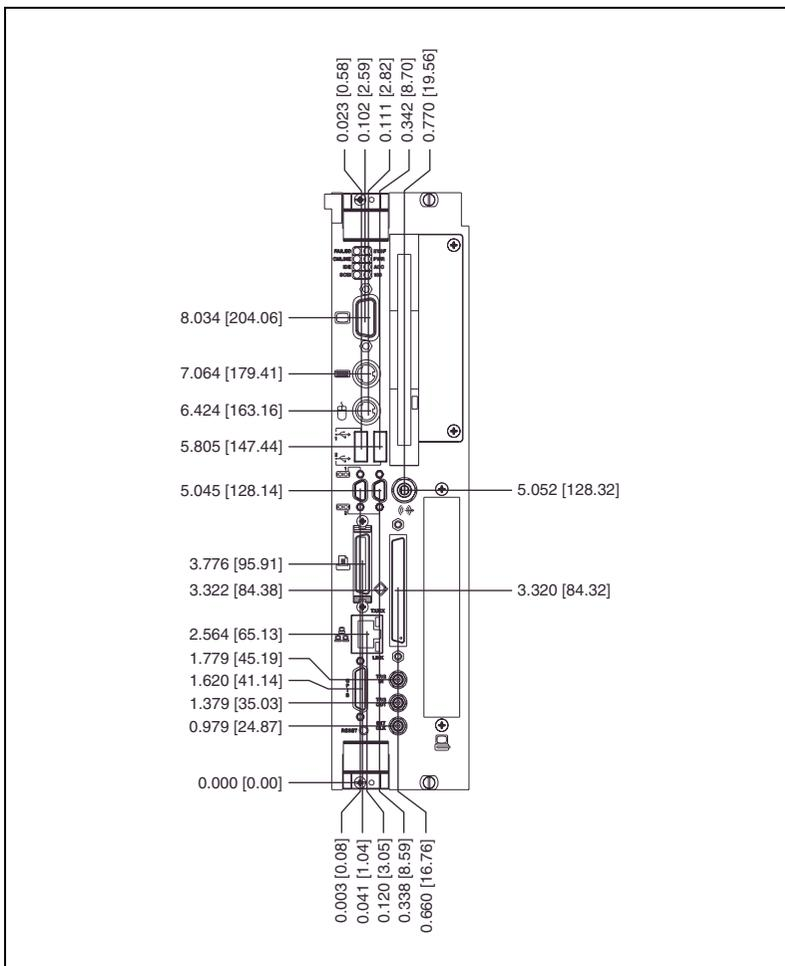

Figure C-3. VXIpc-873 Front Panel Layout and Dimensions
(Option 1 with Internal, Nonremovable Flash Drive)

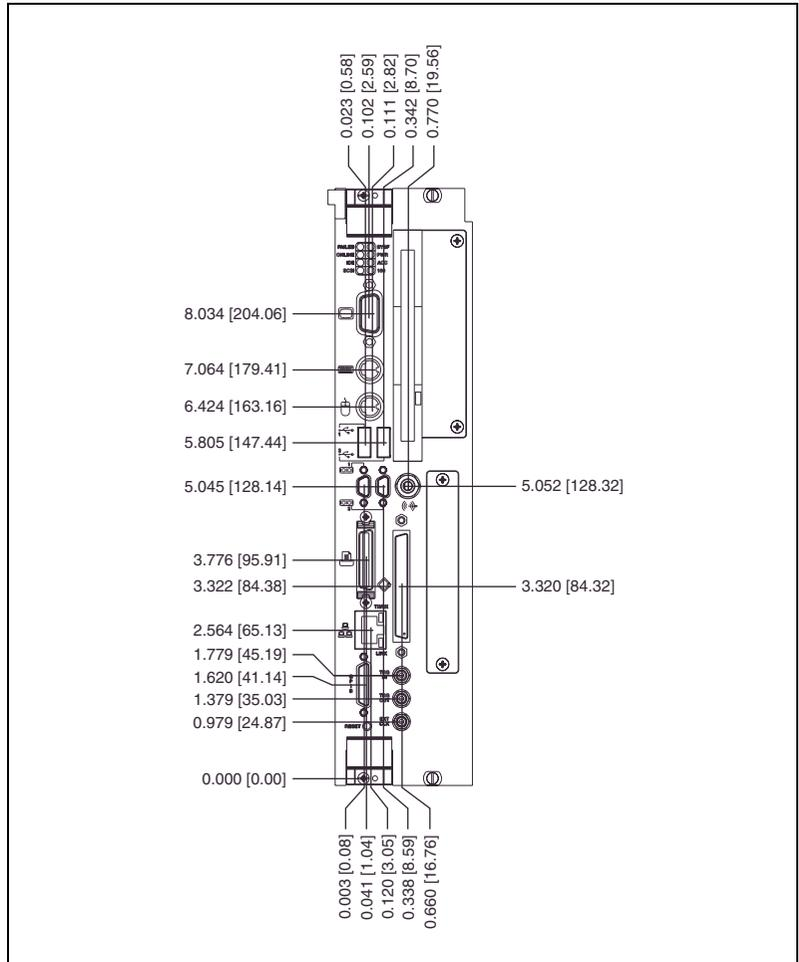

Figure C-4. VXIpc-873 Front Panel Layout and Dimensions
(Option 2 with Removable Flash Drive)

Keyboard and Mouse

Figure C-5 shows the location and pinouts for the keyboard and mouse connectors on the VXIpc 870 Series. Table C-1 gives the name and description for the keyboard and mouse connector signals.

Amp manufactures a mating connector with part numbers 212437-4 (housing), 212435-7 (ferrule), and 66735-4 (pin contact).

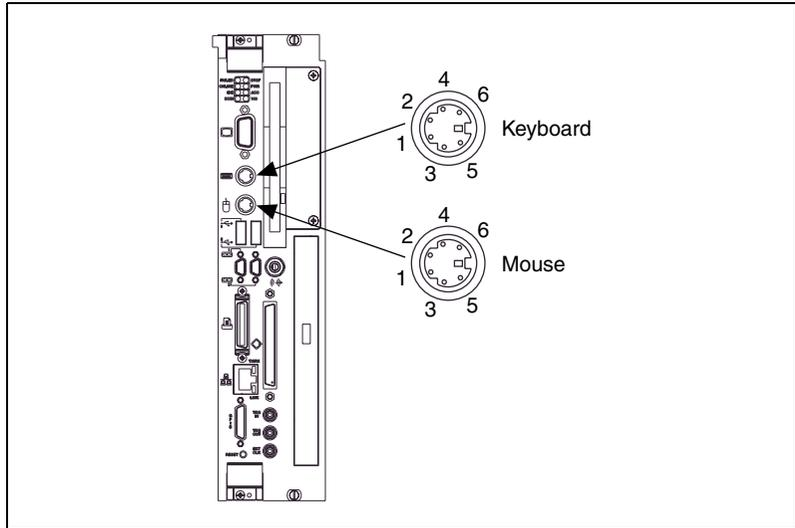

Figure C-5. Keyboard and Mouse Connectors Location and Pinout

Table C-1. Keyboard and Mouse Connector Signals

Pin	Signal Name	Signal Description
1	DATA	Data
2	NC	Not Connected
3	GND	Ground
4	+5V	+5 Volts
5	CLK	Clock
6	NC	Not Connected

SVGA

Figure C-6 shows the location and pinouts for the SVGA connector on the VXIpc 870 Series. Table C-2 gives the name and description for the SVGA connector signals.

Amp manufactures a mating connector with part numbers 748364-1 (housing) and 748333-2 (pin contact).

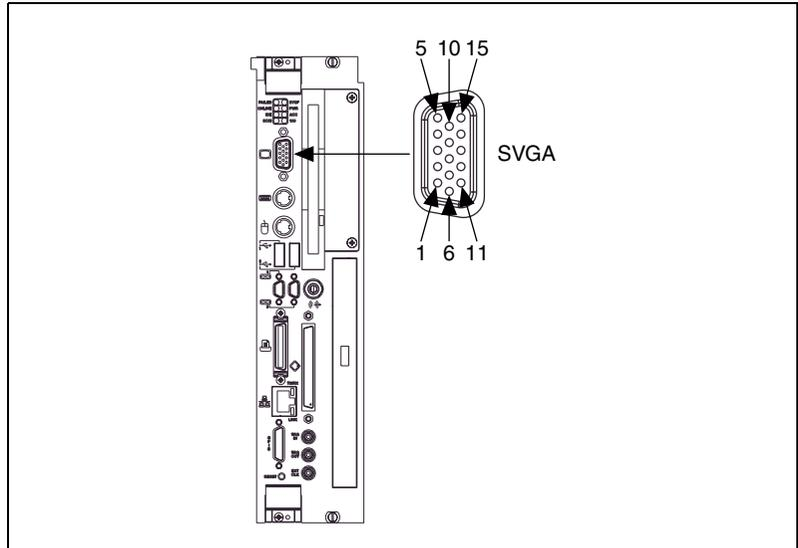

Figure C-6. SVGA Connector Location and Pinout

Table C-2. SVGA Connector Signals

Pin	Signal Name	Signal Description
1	R	Red
2	G	Green
3	B	Blue
4	NC	Not Connected
5	GND	Ground
6	GND	Ground
7	GND	Ground

Table C-2. SVGA Connector Signals (Continued)

Pin	Signal Name	Signal Description
8	GND	Ground
9	NC	Not Connected
10	GND	Ground
11	NC	Not Connected
12	SD	Serial Data
13	HSync	Horizontal Sync
14	VSync	Vertical Sync
15	SC	Serial Clock

Ethernet

Figure C-7 shows the location and pinouts for the Ethernet connector on the VXIpc 870 Series Table C-3 gives the name and description for the Ethernet connector signals.

Amp manufactures a mating connector, part number 554739-1.

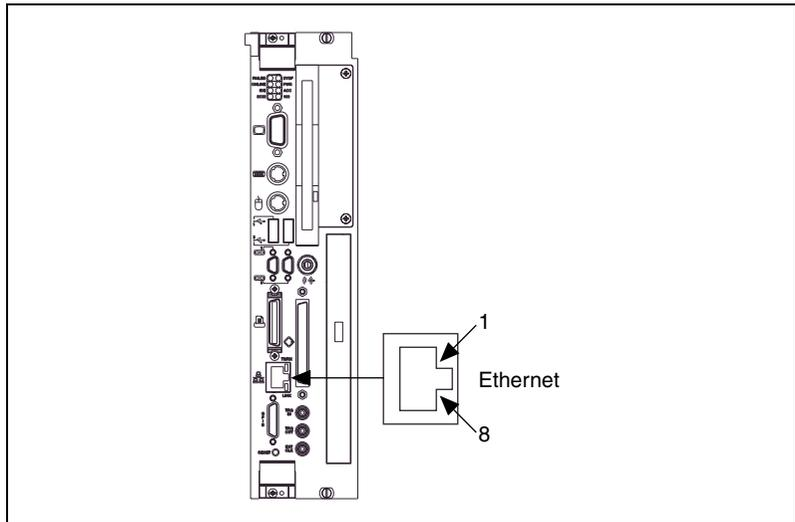

Figure C-7. Ethernet Connector Location and Pinout.

Table C-3. Ethernet Connector Signals

Pin	Signal Description
1	Differential Transmit +
2	Differential Transmit –
3	Differential Receive +
4	Not Connected
5	Not Connected
6	Differential Receive –
7	Not Connected
8	Not Connected

COM1 and COM2

Figure C-8 shows the location and pinouts for the COM1 and COM2 connectors on the VXIpc 870 Series. Table C-4 gives the name and description for the COM1 and COM2 connector signals.

ITT Cannon manufactures a serial port mating connector, part number MDSM-9SC-Z11, for the COM1 and COM2 connectors.

**Figure C-8.** COM1 and COM2 Connectors Location and Pinout.

Table C-4. COM1 and COM2 Connector Signals

Pin	Signal Name	Signal Description
1	DCD*	Data Carrier Detect
2	RXD*	Receive Data
3	TXD*	Transmit Data
4	DTR*	Data Terminal Ready
5	GND	Ground
6	DSR*	Data Set Ready
7	RTS*	Ready to Send
8	CTS*	Clear to Send
9	RI*	Ring Indicator

Parallel Port

Figure C-9 shows the location and pinouts for the IEEE-1284 connector on the VXIpc 870 Series. Table C-5 gives the name and description for the IEEE-1284 connector signals. Amp manufactures a parallel port compatible connector, part number 2-175677-5.

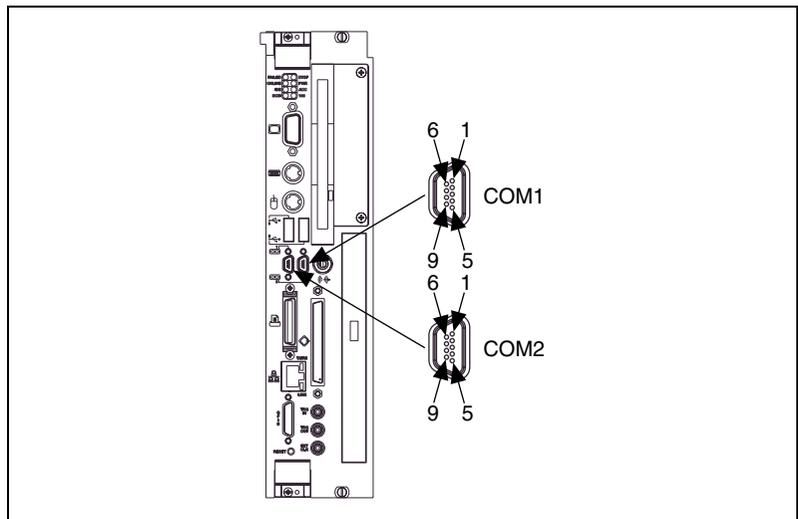
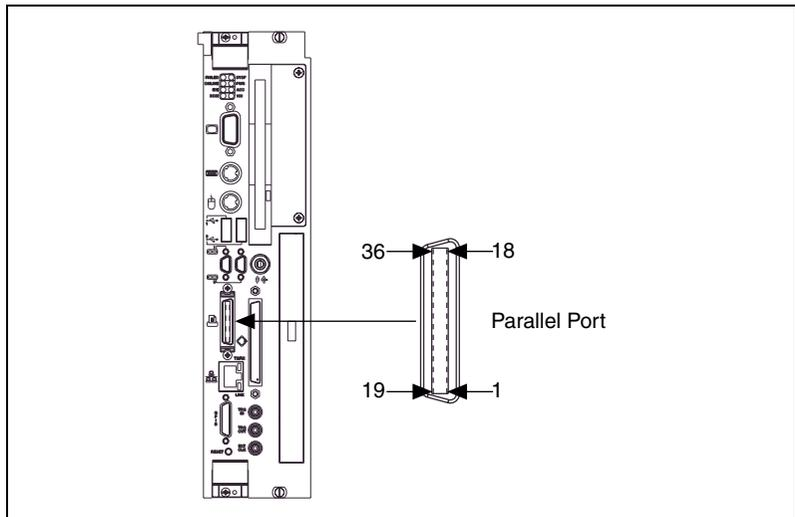

Figure C-9. Parallel Port Connector Location and Pinout

Table C-5. Parallel Port Connector Signals

Pin	Signal Name	Signal Description
1	BUSY*	Device Busy
2	SLCTIN*	Select Input
3	ACK*	Acknowledge
4	FAULT*	Fault
5	ERROR	Error
6	PD0	Data Bit 0
7	PD1	Data Bit 1
8	PD 2	Data Bit 2
9	PD3	Data Bit 3
10	PD4	Data Bit 4
11	PD5	Data Bit 5
12	PD6	Data Bit 6
13	PD7	Data Bit 7
14	INIT*	Initialize Printer
15	STROBE*	Strobe
16	SLCT	Select
17	AUTOFD	Auto Line Feed
18	+5V	+5 V
19–35	GND	Ground
36	NC	Not Connected

Universal Serial Bus

Figure C-10 shows the location and pinouts for the two Universal Serial Bus (USB) connectors on the VXIpc 870 Series. Table C-6 gives the name and description for the USB connector signals.

Amp manufactures a mating connector, part number 787633.

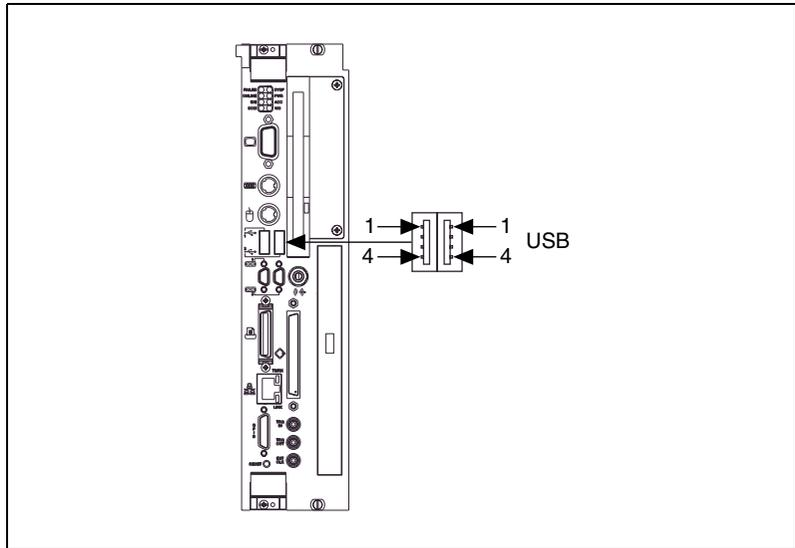

Figure C-10. USB Connectors Location and Pinout

Table C-6. USB Connector Signals

Pin	Signal Name	Signal Description
1	VCC	Cable Power (+5 V)
2	-Data	USB Data-
3	+Data	USB Data+
4	GND	Ground

SCSI

Figure C-11 shows the location and pinouts for the Ultra Wide SCSI connector on the VXIpc 870 Series. Table C-7 gives the name and description for the SCSI connector signals.

Amp manufactures a SCSI compatible connector, part number 749111-6, with shielded enclosure 750752-1.

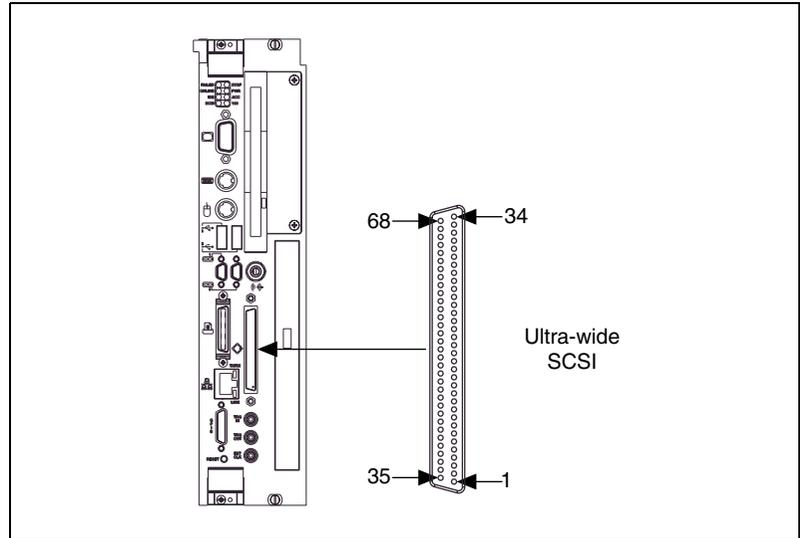

Figure C-11. SCSI Connector Location and Pinout

Table C-7. 16-Bit Wide SCSI-3 “P” (Primary) Connector Pinout (Single Ended)

SCSI Signal	High Density 68-Pin Connector	SCSI Signal	High Density 68-Pin Connector
GND	1	DB(12)*	35
GND	2	DB(13)*	36
GND	3	DB(14)*	37
GND	4	DB(15)*	38
GND	5	DP1	39
GND	6	DB(0)*	40

Table C-7. 16-Bit Wide SCSI-3 “P” (Primary) Connector Pinout
(Single Ended) (Continued)

SCSI Signal	High Density 68-Pin Connector	SCSI Signal	High Density 68-Pin Connector
GND	7	DB(1)*	41
GND	8	DB(2)*	42
GND	9	DB(3)*	43
GND	10	DB(4)*	44
GND	11	DB(5)*	45
GND	12	DB(6)*	46
GND	13	DB(7)*	47
GND	14	DP0	48
GND	15	GND	49
GND	16	GND	50
TERMPWR	17	TERMPWR	51
TERMPWR	18	TERMPWR	52
RSRVD	19	RSRVD	53
GND	20	GND	54
GND	21	ATN*	55
GND	22	GND	56
GND	23	BSY*	57
GND	24	ACK*	58
GND	25	RST*	59
GND	26	MSG*	60
GND	27	SEL*	61
GND	28	C/D*	62
GND	29	REQ*	63
GND	30	I/O*	64

Table C-7. 16-Bit Wide SCSI-3 “P” (Primary) Connector Pinout (Single Ended) (Continued)

SCSI Signal	High Density 68-Pin Connector	SCSI Signal	High Density 68-Pin Connector
GND	31	DB(8)*	65
GND	32	DB(9)*	66
GND	33	DB(10)*	67
GND	34	DB(11)*	68

GPIO (IEEE-488.2)

Figure C-12 shows the location and pinouts for the GPIO connector on the VXIpc 870 Series. Table C-8 gives the name and description for the GPIO connector signals.

ITT Cannon manufactures a GPIO mating connector, part number MDSM-255C-Z11.

**Figure C-12.** GPIO Connector Location and Pinout

Table C-8. GPIB Connector Signals

Pin	Signal Name	Signal Description
1	DIO1*	Data Bit 1
2	DIO2*	Data Bit 2
3	DIO3*	Data Bit 3
4	DIO4*	Data Bit 4
5	EOI*	End or Identify
6	DAV*	Data Valid
7	NRFD*	Not Ready for Data
8	NDAC*	Not Data Accepted
9	IFC*	Interface Clear
10	SRQ*	Service Request
11	ATN*	Attention
12	SHIELD	Chassis ground
13	DIO5*	Data Bit 5
14	DIO6*	Data Bit 6
15	DIO7*	Data Bit 7
16	DIO8*	Data Bit 8
17	REN*	Remote Enable
18–25	GND	Logic Ground

External SMBs

Figure C-13 shows the location and pinouts for the SMB connectors on the VXIpc 870 Series. The SMB connectors are used for an external clock signal and TTL trigger input and output. Table C-9 gives the name and description for the SMB connector signals. Also see Table C-10 for a description of the signal characteristics for the SMB connections.

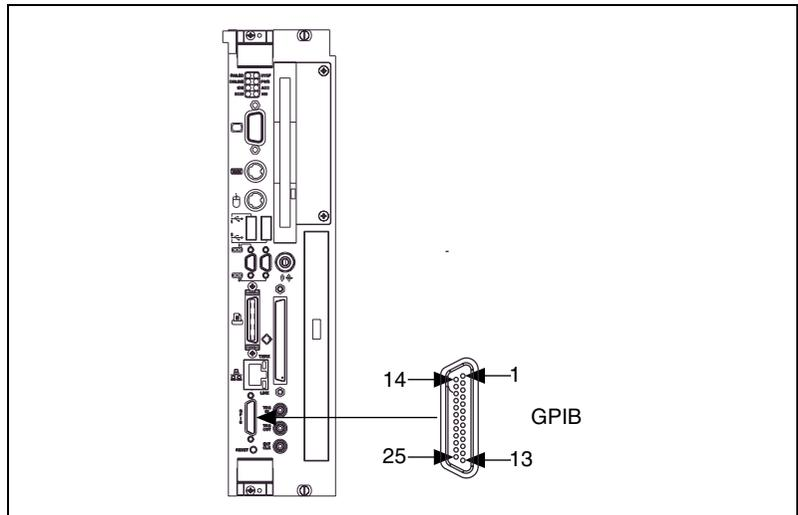
Amp manufactures an SMB mating connector, part number 1-413985-0.

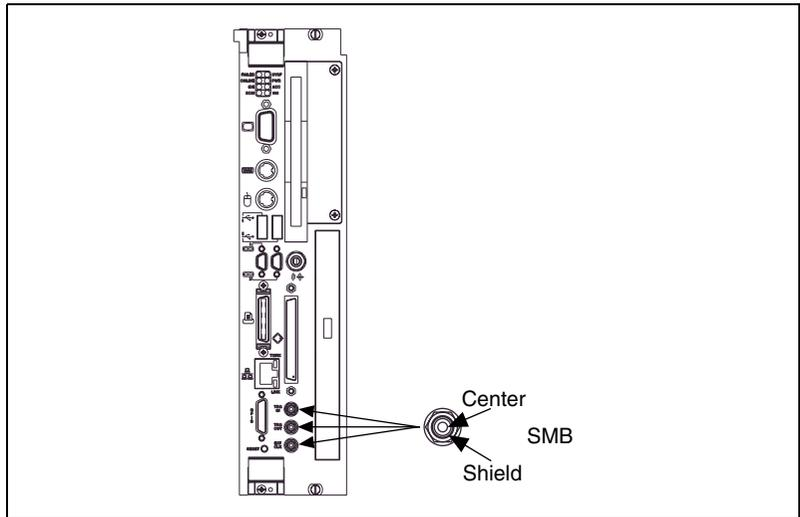

Figure C-13. SMB Connectors Location and Pinout

Table C-9. SMB Connector Signals

Pin	Signal Description
Center	TTL Trigger or Clock Signal
Shield	Ground

Speaker

Figure C-14 shows the location of the speaker connection on the VXIpc 870 Series.

Switchcraft manufactures a mating speaker connector, part number 750.

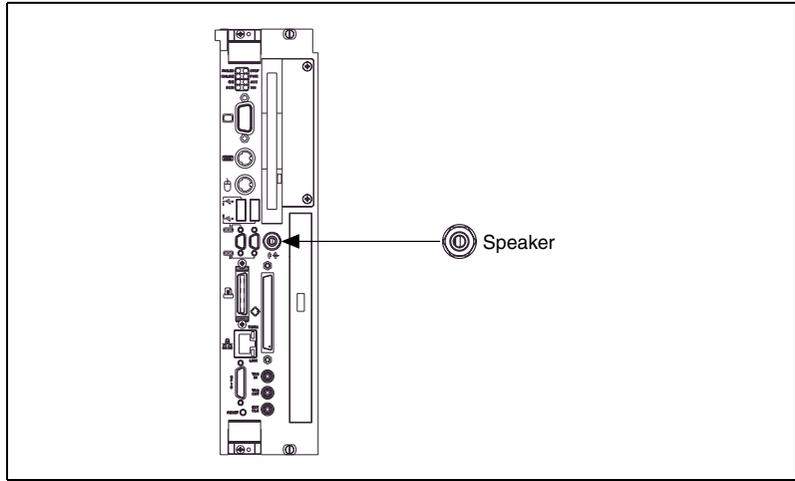

Figure C-14. Speaker Connection Location

Signal Characteristics

Refer to the relevant standard for the signal characteristics for VGA, SCSI, Ethernet, keyboard, mouse, parallel, serial, and GPIB.

Table C-10 shows the signal characteristics for the SMB and speaker connections.

Table C-10. Signal Characteristics for SMB and Speaker Connections

Signal	Voltage Range	Maximum Current	Frequency Range
SMB (TRIG out, CLK out)	0 to 3.4 V	200 mA	DC-10 MHz
SMB (TRIG in)	0 to 5 V	100 mA*	DC-10 MHz
Speaker	0 to 4.3 V	75 mA	DC-20 kHz
* With 50 Ω termination			

VXibus P1 and P2

Figure C-15 shows the location and pinouts for the VXibus connector on the VXIpc 870 Series. Table C-11 gives the name and description for the VXibus P1 connector signals. Table C-12 gives the name and description for the VXibus P2 connector signals.

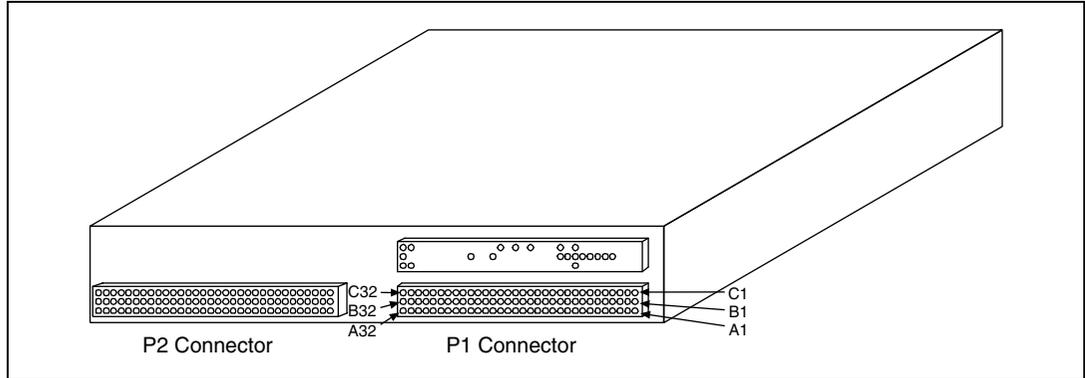

Figure C-15. VXibus Connectors Location and Pinout

Table C-11. VXibus P1 Connector Signals

Pin	Row C	Row B	Row A
1	D08	BBSY*	D00
2	D09	BCLR*	D01
3	D10	ACFAIL*	D02
4	D11	BG0IN*	D03
5	D12	BG0OUT*	D04
6	D13	BG1IN*	D05
7	D14	BG1OUT*	D06
8	D15	BG2IN*	D07
9	GND	BG2OUT*	GND
10	SYSFAIL*	BG3IN*	SYSCLK
11	BERR*	BG3OUT*	GND
12	SYSRESET*	BR0*	DS1*
13	LWORD*	BR1*	DS0*

Table C-11. VXIbus P1 Connector Signals (Continued)

Pin	Row C	Row B	Row A
14	AM5	BR2*	WRITE*
15	A23	BR3*	GND
16	A22	AM0	DTACK*
17	A21	AM1	GND
18	A20	AM2	AS*
19	A19	AM3	GND
20	A18	GND	IACK*
21	A17	Not Connected	IACKIN*
22	A16	Not Connected	IACKOUT*
23	A15	GND	AM4
24	A14	IRQ7*	A07
25	A13	IRQ6*	A06
26	A12	IRQ5	A05
27	A11	IRQ4	A04
28	A10	IRQ3	A03
29	A09	IRQ2	A02
30	A08	IRQ1	A01
31	+12 V	Not Connected	-12 V
32	+5 V	+5 V	+5 V

Table C-12. VXIbus P2 Connector Signals

Pin	Row C	Row B	Row A
1	CLK10+	+5 V	ECLTRG0
2	CLK10-	GND	-2 V
3	GND	Not Connected	ECLTRG1
4	-5.2 V	A24	GND
5	Not Connected	A25	MODID12

Table C-12. VXIbus P2 Connector Signals (Continued)

Pin	Row C	Row B	Row A
6	Not Connected	A26	MODID11
7	GND	A27	-5.2 V
8	Not Connected	A28	MODID10
9	Not Connected	A29	MODID09
10	GND	A30	GND
11	Not Connected	A31	MODID08
12	Not Connected	GND	MODID07
13	-2 V	+5 V	-5.2 V
14	Not Connected	D16	MODID06
15	Not Connected	D17	MODID05
16	GND	D18	GND
17	Not Connected	D19	MODID04
18	Not Connected	D20	MODID03
19	-5.2 V	D21	-5.2 V
20	Not Connected	D22	MODID02
21	Not Connected	D23	MODID01
22	GND	GND	GND
23	TTLTRG1*	D24	TTLTRG0*
24	TTLTRG3*	D25	TTLTRG2*
25	GND	D26	+5 V
26	TTLTRG5*	D27	TTLTRG4*
27	TTLTRG7*	D28	TTLTRG6*
28	GND	D29	GND
29	Not Connected	D30	Not Connected
30	GND	D31	MODID00
31	Not Connected	GND	GND
32	Not Connected	+5 V	Not Connected

Modifying and Installing I/O Expansion Boards

This appendix explains how to modify and install an I/O board in the VXIpc-872 and VXIpc-873 with a nonremovable flash drive. This information does not apply to the VXIpc-871 or VXIpc-873 with a removable flash drive.



Note Throughout this chapter, *VXIpc-873* refers only to VXIpc-873 controllers with nonremovable flash drives.

Height of Plug-In Boards

In general, the VXIpc-872 and VXIpc-873 can accommodate any standard-size PCI card and any XT-height ISA card. The height of an I/O card is measured from the bottom of the bus connector to the top of the board, as shown in Figure D-1.

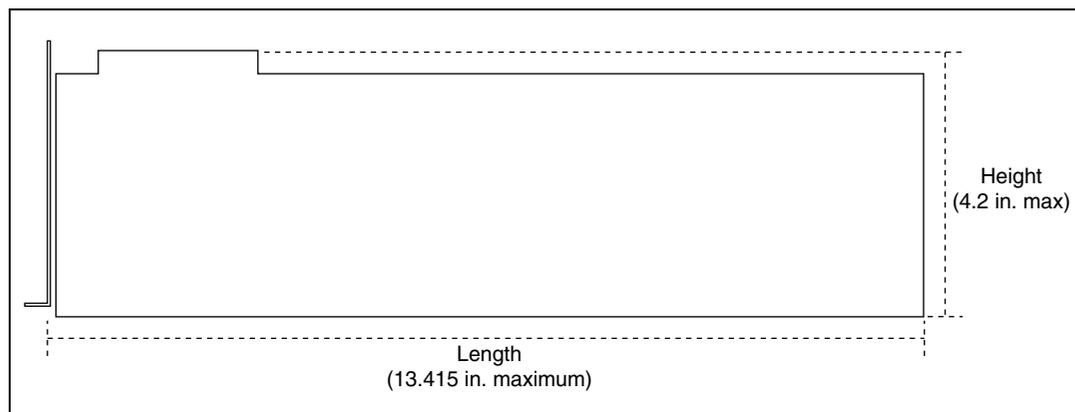

Figure D-1. I/O Board Dimensions for VXIpc-872 Expansion Slot

Both XT-height ISA cards and PCI cards are 4.2 in. high. The VXIpc-872 and VXIpc-873 do not support AT-height ISA cards, which are 4.8 in. high.

Installing an I/O Board

This section leads you through the steps to install an expansion board in the VXIpc-872 and VXIpc-873.

Materials Needed

You need the following items to install the expansion board:

- A user-defined panel is required on the expansion boards based on National Instruments blank PCI or ISA panels. The panel should be manufactured from 0.03 in. (0.76 mm) thick 1010 cold rolled steel. The finish should be 0.0003 in. (0.008 mm) nickel plate over 0.0001 in. (0.003 mm) copper flash. Contact National Instruments if you have any questions about specifications for user-defined panels.

As an alternative, you can modify the blank panels provided with the VXIpc-872 and VXIpc-873. Custom panel design services are available from National Instruments for a nominal fee.

- PEM nut or a 4-40 nut with lock washer (hole diameter should be 0.125 in. [3.18 mm]).
- 4-40 × 1/4 in. stainless steel panhead screw.

Installation Steps

Follow these steps to install the expansion board:

1. Notice that the VXIpc-872 and VXIpc-873 include one card guide that can be rotated to secure the top of either a PCI or an ISA plug-in board. You may use the card guide in either of two locations, depending on the length of your installed board. Loosen the screw holding the guide and rotate the guide to the uppermost position for PCI boards or the lowermost position for ISA boards. See Figure D-2.
2. Replace the manufacturer-supplied panel bracket with the custom bracket. The two holes in the bracket align with existing holes in the VXIpc-872 or VXIpc-873 front panel.
3. Seat the board firmly in one of the expansion bus connectors.
4. Attach the board to the front panel with the two screws. You can use a PEM nut on the back (far) side of the bracket, or a 4-40 nut with a lock washer (hole diameter should be 0.125 in.). In either case, use a 4-40 × 1/4 in. stainless steel panhead screw to mount the board/bracket assembly to the front panel.

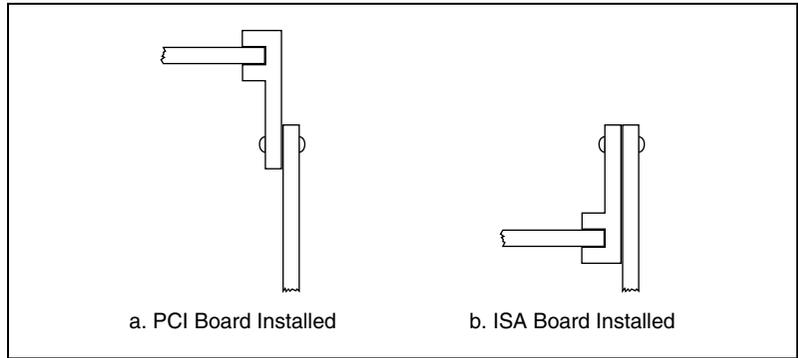

Figure D-2. PCI Board and ISA Board Installed in a VXIpc-872 or VXIpc-873



Note In the following drawings, dimensions are given in inches and millimeters, with the millimeter dimensions in square brackets.

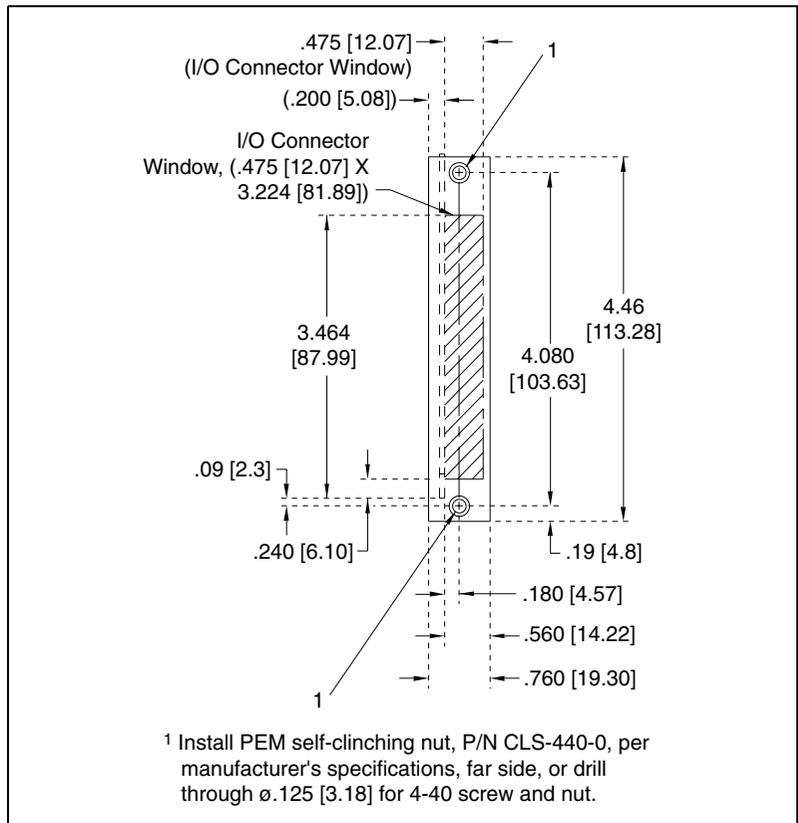

Figure D-3. Front View of PCI Board Expansion Bracket

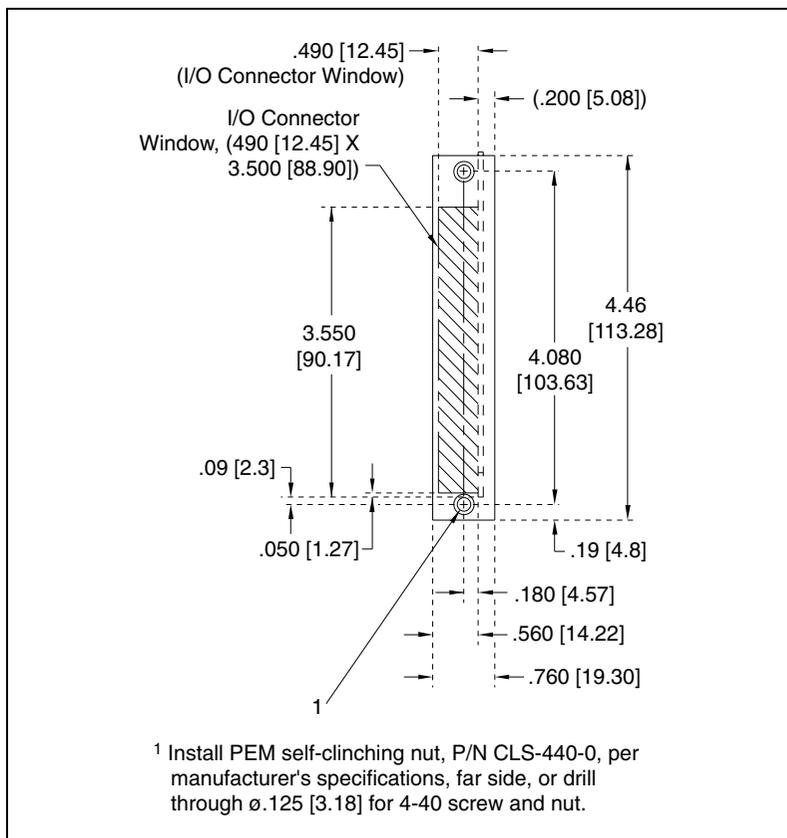

Figure D-4. Front View of ISA Board Expansion Bracket

Common Questions

This appendix answers common questions you may have when using the VXIpc 870 Series.

What do the LEDs on the front of the VXIpc 870 Series mean?

Refer to Appendix B, *LED Indicators*, for a description of the front panel LEDs.

Is something wrong if the red SYSF and FAIL LEDs stay lit after booting the VXIpc 870 Series?

If either the **SYSF** or **FAIL** LED remains lit, refer to Appendix B, *LED Indicators*, for troubleshooting steps.

Can I access 32-bit registers in my VXIbus system from the VXIpc 870 Series?

Yes. The VXIpc 870 Series uses the 32-bit PCI bus to interface to the VXIbus. In fact, its VXIbus circuitry also supports the VME64 standard for D64 accesses.

What kind of signal is CLK10 and what kind of signal do I need for an external CLK10?

CLK10 is a differential ECL signal on the backplane. However, because the oscillator and the EXTCLK input on the front panel use TTL levels, you need to supply a TTL-level signal for EXTCLK. Our voltage converters convert the signal to differential ECL.

What is the accuracy of the CLK10 signal?

The CLK10 signal generated by the VXIpc 870 Series is ± 100 ppm (0.01%) as per the VXIbus specification. If you need a more accurate CLK10 signal, you can use the CLKI/O connector on the front panel.

What if my keyboard connector does not fit into the keyboard port?

You can plug keyboards that have a 6-pin PS/2 type connector directly into the VXIpc 870 Series. Your kit also includes a keyboard adapter cable that you can use to adapt the larger AT keyboard connector to the 6-pin PS/2 connector.

What do I need to do if I want to install the VXIpc 870 Series in a slot other than Slot 0?

The VXIpc 870 Series automatically detects whether it is in Slot 0 of a VXIbus mainframe. You do not need to change jumper settings to install the device in a slot other than Slot 0 unless you have defeated the first slot detector (FSD) circuitry by changing the J22 jumper setting.

Remember that devices in all other slots must not be manually configured as System Controller (Slot 0) devices. They must be configured either for automatic first slot detection or manual non-System Controller.

Refer to Chapter 2, *Configuration and Installation*, for information on enabling and defeating the FSD circuitry.

How do I check the configuration of the memory, floppy drive, hard drive, time/date, and so on?

You can view these parameters in the BIOS setup. To enter the BIOS setup, reboot the VXIpc 870 Series and press the key during the memory tests. Refer to Chapter 6, *BIOS*, for more information.

How can I boot from an external SCSI hard drive?

In the BIOS setup change the boot sequence to SCSI.

Can I boot off the CD-ROM of the VXIpc 870?

Yes, by changing the boot sequence to CD-ROM in the BIOS setup. Refer to Chapter 6, *BIOS*, for more information.

Can I use the internal IDE drive and an external SCSI hard drive at the same time?

Yes, you can select which device to boot from in the BIOS setup. Refer to Chapter 6, *BIOS*, for information on entering BIOS.

My CMOS is corrupted. How do I set it back to default?

1. Enter the BIOS setup program as described in Chapter 6, *BIOS*.
2. Select **Optimal Defaults**.
3. Select **Save and Exit**.

My operating system is damaged but my hard drive is OK. How can I re-install the operating system?

Do the following:

1. Make a bootable floppy disk. Make sure the disk contains `deltree`.
2. Boot the machine from the disk.
3. Run `deltree C:*.*` and answer yes to all files and directories except `C:\Images`.
 - If using Windows NT:
 - Go to `C:\Images\os\wint\I386` directory and run `Winnt /B`.
 - If using Windows 98:
 - Go to `C:\Images\os\Win98` and run `Setup`.
4. Install all IO drivers from `C:\Images\VXI870\...`

What about running Resman?

Resman is the name of the utility that performs the duties of a VXI Resource Manager as discussed in the VXIbus specification. When you set a National Instruments controller to Logical Address 0, you will at some point need to run Resman to configure your VXI instruments. If your controller uses a different (non-zero) logical address and is a message-based device, start Resman before running it on the Logical Address 0 computer.

When do you need to run Resman?

Run Resman whenever you need to configure your VXI instruments. For example, if you power-cycle your VXI/VME chassis, your instruments will be reset, and you will need to run Resman to configure them. You can get into trouble if you run Resman when your devices are not in a reset state. Therefore, if you have to run Resman after running it once, you should reset all of your VXI instruments.

You can perform resource manager operations from within T&M Explorer. Additionally, you can tell T&M Explorer to run Resman when the computer first boots up. In this case you may never need to run Resman explicitly again. You can configure the computer to run Resman at startup,

so when you power the chassis, Resman runs. If you power-cycle the chassis, the PC reboots, forcing Resman to run again.

How do I handle VME devices?

Although there is no way to automatically detect VME devices in a system, you can add them easily through the **Add Device Wizard** in T&M Explorer. Through this procedure, you can reserve resources for each of your VME devices and configure T&M Explorer to show VME devices on the screen with all your other devices.

How can I determine which version of the NI-VXI/VISA software I have installed?

Following are several ways to find this information:

- From T&M Explorer, select **About...** from the **Help** menu. In the **About** dialog box, press the **Software Info** button. This displays version information on NI-VXI and NI-VISA files.
- Under Windows NT and Windows 98, you can find version information by right-clicking on any component and selecting the **Properties** option. This displays a property sheet with a version tab. This tab has version information about the product (NI-VXI) and the component (NIVXINT.DLL, for example).
- You can find version information about the NI-VXI driver by running the VIC utility program. Type `ver` at the prompt, and the utility displays the versions of VIC and NI-VXI, and the latest VXIpc hardware revision that this NI-VXI driver supports.
- You can find version information about the VISA driver through VISAIC by selecting **About...** from the **Help** menu.

How can I determine the serial number and hardware revision of the VXIpc embedded computers?

Run T&M Explorer and right-click on the name of the VXIpc. Select **Hardware Configuration**, and T&M Explorer displays the dialog box for the device. The title bar includes the serial number and hardware revision.

Which NI-VXI utility program must I use to configure the VXIpc 870 Series?

Use the T&M Explorer program to configure the VXIpc. T&M Explorer is located in the NIVXI program group folder.

Which NI-VXI utility program must I use to initialize the VXIpc 870 Series?

In Windows NT/98, the VXIpc embedded computer is automatically initialized at system startup.

Which NI-VXI utility program must I use to perform startup Resource Manager operations?

Use the Resman program to perform startup Resource Manager operations. It is located in the `NIVXI` directory. Resman uses the settings configured in T&M Explorer. It initializes your VXIbus system and stores the information that it collects to the `RESMAN.TBL` file in the `TBL` subdirectory of the `NIVXI` directory.

You can also run Resource Manager operations from T&M Explorer. Through T&M Explorer, you can also configure Resman to run automatically at computer startup.

What can I do to make sure that my system is up and running?

The fastest method for testing the system is to run Resman. This program attempts to access memory in the upper A16 address space of each device in the system. If Resman does not report any problems, the VXI communication system is operational.

To test individual devices, you can use the VIC or VISAIC program to interactively issue NI-VXI functions or NI-VISA operations, respectively. You can use the `VXIin()` and `VXIout()` functions or the `VXIinReg()` and `VXIoutReg()` functions to test register-based devices by programming their registers. If you have any message-based devices, you can send and receive messages with the `WSwrT()` and `WSrd()` functions.

Finally, if you are using LabVIEW or LabWindows/CVI and you have instrument drivers for the devices in your chassis, you can use the interactive features of these programs to quickly test the functionality of the devices.

Technical Support Resources

This appendix describes the comprehensive resources available to you in the Technical Support section of the National Instruments Web site and provides technical support telephone numbers for you to use if you have trouble connecting to our Web site or if you do not have internet access.

NI Web Support

To provide you with immediate answers and solutions 24 hours a day, 365 days a year, National Instruments maintains extensive online technical support resources. They are available to you at no cost, are updated daily, and can be found in the Technical Support section of our Web site at www.ni.com/support

Online Problem-Solving and Diagnostic Resources

- **KnowledgeBase**—A searchable database containing thousands of frequently asked questions (FAQs) and their corresponding answers or solutions, including special sections devoted to our newest products. The database is updated daily in response to new customer experiences and feedback.
- **Troubleshooting Wizards**—Step-by-step guides lead you through common problems and answer questions about our entire product line. Wizards include screen shots that illustrate the steps being described and provide detailed information ranging from simple getting started instructions to advanced topics.
- **Product Manuals**—A comprehensive, searchable library of the latest editions of National Instruments hardware and software product manuals.
- **Hardware Reference Database**—A searchable database containing brief hardware descriptions, mechanical drawings, and helpful images of jumper settings and connector pinouts.
- **Application Notes**—A library with more than 100 short papers addressing specific topics such as creating and calling DLLs, developing your own instrument driver software, and porting applications between platforms and operating systems.

Software-Related Resources

- **Instrument Driver Network**—A library with hundreds of instrument drivers for control of standalone instruments via GPIB, VXI, or serial interfaces. You also can submit a request for a particular instrument driver if it does not already appear in the library.
- **Example Programs Database**—A database with numerous, non-shipping example programs for National Instruments programming environments. You can use them to complement the example programs that are already included with National Instruments products.
- **Software Library**—A library with updates and patches to application software, links to the latest versions of driver software for National Instruments hardware products, and utility routines.

Worldwide Support

National Instruments has offices located around the globe. Many branch offices maintain a Web site to provide information on local services. You can access these Web sites from www.ni.com/worldwide

If you have trouble connecting to our Web site, please contact your local National Instruments office or the source from which you purchased your National Instruments product(s) to obtain support.

For telephone support in the United States, dial 512 795 8248. For telephone support outside the United States, contact your local branch office:

Australia 03 9879 5166, Austria 0662 45 79 90 0, Belgium 02 757 00 20,
Brazil 011 284 5011, Canada (Calgary) 403 274 9391,
Canada (Ontario) 905 785 0085, Canada (Québec) 514 694 8521,
China 0755 3904939, Denmark 45 76 26 00, Finland 09 725 725 11,
France 01 48 14 24 24, Germany 089 741 31 30, Greece 30 1 42 96 427,
Hong Kong 2645 3186, India 91805275406, Israel 03 6120092,
Italy 02 413091, Japan 03 5472 2970, Korea 02 596 7456,
Mexico (D.F.) 5 280 7625, Mexico (Monterrey) 8 357 7695,
Netherlands 0348 433466, New Zealand 09 914 0488,
Norway 32 27 73 00, Poland 0 22 528 94 06, Portugal 351 1 726 9011,
Singapore 2265886, Spain 91 640 0085, Sweden 08 587 895 00,
Switzerland 056 200 51 51, Taiwan 02 2528 7227,
United Kingdom 01635 523545

Glossary

Prefix	Meanings	Value
p-	pico-	10^{-12}
n-	nano-	10^{-9}
μ -	micro-	10^{-6}
m-	milli-	10^{-3}
k-	kilo-	10^3
M-	mega-	10^6
G-	giga-	10^9
t-	tera-	10^{12}

Symbols

° degrees

Ω ohms

A

A amperes

A24 space VXIbus address space equivalent to the VME 16 MB standard address space

A32 space VXIbus address space equivalent to the VME 4 GB extended address space

address character code that identifies a specific location (or series of locations) in memory

address space	a set of 2^n memory locations differentiated from other such sets in VXI/VMEbus systems by six addressing lines known as address modifiers. n is the number of address lines required to uniquely specify a byte location in a given space. Valid numbers for n are 16, 24, and 32. In VME/VXI, because there are six address modifiers, there are 64 possible address spaces.
ANSI	American National Standards Institute
API	Application Programming Interface; the direct interface that an end user sees when creating an application
ASD	Acceleration Spectral Density; a calculation of random vibration intensity across a frequency bandwidth
ASIC	application-specific integrated circuit—a proprietary semiconductor component designed and manufactured to perform a set of specific functions for a specific customer
B	
b	bit—one binary digit, either 0 or 1
B	byte—eight related bits of data, an 8-bit binary number. Also used to denote the amount of memory required to store one byte of data.
backplane	an assembly, typically a printed circuit board, with 96-pin connectors and signal paths that bus the connector pins. A C-size VXIbus system will have two sets of bused connectors called J1 and J2. A D-size VXIbus system will have three sets of bused connectors called J1, J2, and J3.
BERR*	bus error signal
BIOS	Basic Input/Output System. BIOS functions are the fundamental level of any PC or compatible computer. BIOS functions embody the basic operations needed for successful use of the computer's hardware resources.
bus	the group of conductors that interconnect individual circuitry in a computer. Typically, a bus is the expansion vehicle to which I/O or other devices are connected. Examples of buses include the ISA bus, PCI bus, VXI bus, and VME bus.

bus error an error that signals failed access to an address. Bus errors occur with low-level accesses to memory and usually involve hardware with bus mapping capabilities. For example, nonexistent memory, a nonexistent register, or an incorrect device access can cause a bus error.

C

C Celsius

CLK10 a 10 MHz, ± 100 ppm, individually buffered (to each module slot), differential ECL system clock that is sourced from Slot 0 of a VXIbus mainframe and distributed to Slots 1 through 12 on P2. It is distributed to each slot as a single-source, single-destination signal with a matched delay of under 8 ns.

CMOS Complementary Metal Oxide Semiconductor; a process used in making chips

D

DIN Deutsches Institut für Normung—German Standards Institute

DMA Direct Memory Access; a method by which data is transferred between devices and internal memory without intervention of the central processing unit. DMA is the fastest method of transferring data to/from computer memory.

DRAM Dynamic RAM (Random Access Memory); storage that the computer must refresh at frequent intervals

E

ECL Emitter-Coupled Logic

EDO Extended Data Out; a DRAM architecture that shortens overall access latency, improving performance

EEPROM Electronically Erasable Programmable Read Only Memory—ROM that can be erased with an electrical signal and reprogrammed

embedded controller an intelligent CPU (controller) interface plugged directly into the VXI backplane, giving it direct access to the VXIbus. It must have all of its required VXI interface capabilities built in.

EMC electromagnetic compliance

EMI electromagnetic interference

external trigger a voltage pulse from an external source that triggers an event

F

fair requester a VXIbus device that will not arbitrate for the VXIbus after releasing it until it detects the bus request signal inactive. This ensures that all requesting devices will be granted use of the bus.

G

g 1. grams
2. A measure of acceleration equal to 9.8 m/s²

GPIB General Purpose Interface Bus (IEEE 488)

g_{RMS} A measure of random vibration. The root mean square of acceleration levels in a random vibration test profile.

H

hex hexadecimal; the numbering system with base 16, using the digits 0 to 9 and letters A to F

Hz hertz; cycles per second

I

IDE Integrated Drive Electronics. Denotes the most common interface to the hard drive on PCs.

IEC International Electrotechnical Commission. The IEC publishes internationally recognized standards. IEC 60068 contains information on environmental testing procedures and severities.

IEEE	Institute of Electrical and Electronics Engineers
in.	inches
I/O	input/output; the techniques, media, and devices used to achieve communication between machines and users
instrument driver	a set of routines designed to control a specific instrument or family of instruments, and any necessary related files for LabWindows/CVI or LabVIEW
interrupt	a means for a device to request service from another device; a computer signal indicating that the CPU should suspend its current task to service a designated activity
interrupt handler	a VMEbus functional module that detects interrupt requests generated by interrupters and responds to those requests by requesting status and identify information
interrupt level	the relative priority at which a device can interrupt
IRQ*	interrupt signal
ISA	Industry Standard Architecture; denotes a common expansion bus used in PCs
K	
K	kilo—(1) the standard metric prefix for 1,000, or 10^3 , used with units of measure such as volts, hertz, and meters; (2) the prefix for 1,024, or 2^{10} , used with B (byte) in quantifying data or computer memory
L	
LED	light-emitting diode

M

m	meters
M	mega—(1) the standard metric prefix for 1 million or 10^6 , when used with units of measure such as volts and hertz; (2) the prefix for 1,048,576, or 2^{20} , when used with B (byte) to quantify data or computer memory
MANTIS	a National Instruments custom ASIC that performs VXIbus arbitration and manages interrupts and triggers
master	a functional part of a VME/VXIbus device that initiates data transfers on the backplane. A transfer can be either a read or a write.
MBLT	eight-byte block transfers in which both the Address bus and the Data bus are used to transfer data
MITE	a National Instruments custom ASIC, a sophisticated dual-channel DMA controller that incorporates the Synchronous MXI and VME64 protocols to achieve high-performance block transfer rates
MODID	module ID lines. Used in VXI to geographically locate boards and to dynamically configure boards
MTBF	Mean Time Between Failure

N

NI-488.2 or NI-488.2M	the National Instruments industry-standard software for controlling GPIB instruments
NI-VISA	the National Instruments implementation of the VISA standard; an interface-independent software that provides a unified programming interface for VXI, GPIB, and serial instruments
NI-VXI	the National Instruments bus interface software for VME/VXIbus systems
Non-Slot 0 device	a device configured for installation in any slot in a VXIbus mainframe other than Slot 0. Installing such a device into Slot 0 can damage the device, the VXIbus backplane, or both.

P

PCI	Peripheral Component Interconnect. The PCI bus is a high-performance 32-bit or 64-bit bus with multiplexed address and data lines.
PCMCIA	Personal Computer Memory Card International Association
POSC	Power-On Self Configuration. A process by which the MITE chip programs its own registers from EEPROMs at power up

R

Resource Manager	a message-based Commander located at Logical Address 0, which provides configuration management services such as address map configuration, Commander and Servant mappings, and self-test and diagnostic management
RMS	Root mean squared. <i>See</i> g_{rms} .

S

s	seconds
SCSI	Small Computer System Interface (bus)
SIMM	Single In-line Memory Module
slave	a functional part of a VME/VXibus device that detects data transfer cycles initiated by a VMEbus master and responds to the transfers when the address specifies one of the device's registers
Slot 0 device	a device configured for installation in Slot 0 of a VXibus mainframe. This device is unique in the VXibus system in that it performs the VXI/VMEbus System Controller functions, including clock sourcing and arbitration for data transfers across the backplane. Installing such a device into any other slot can damage the device, the VXibus backplane, or both.
SMB	Sub Miniature Type B connector that features a snap coupling for fast connection

SYSFAIL A VMEbus signal that is used by a device to indicate an internal failure. A failed device asserts this line. In VXI, a device that fails also clears its PASSED bit in its Status register.

T

trigger either TTL or ECL lines used for intermodule communication

TTL Transistor-Transistor Logic

V

V volts

VGA Video Graphics Array; the minimum video display standard for all PCs

VISA Virtual Instrument Software Architecture. This is the general name given to VISA and its associated architecture.

VME Versa Module Eurocard or IEEE 1014

VXIbus VMEbus Extensions for Instrumentation

Index

A

- ACC LED, B-3
- adapter cables, 2-2
- AGP Graphics, 5-3
- application software, 1-5
- assembly number (figure), 3-1
- automatic-detection configuration, 3-6, E-5
 - automatic slot detection (J22) (figure), 3-1

B

BIOS

- See also* CMOS.
- boot drive, E-2
- checking configuration, E-2
- default setup settings, 6-1, E-2
- entering setup, 6-1
- FAILSAFE defaults, 6-1
- features, 6-1
- functional overview, 5-5
- OPTIMAL defaults, 6-1

block diagram, 5-2

board access LEDs

- ACC LED, B-3
- DRV LED, B-3
- SCSI LED, B-3

bus speed (W4) (figure), 3-1

C

- CD-ROM, booting from, E-2
- chip set, SDRAM, 5-2
- CLK10
 - configuration, 3-5
 - definition of, E-1
 - external clock, 5-7
 - onboard logic, 3-7

- routing and termination, 3-5, 3-7
- signal accuracy, E-1
- signal generation, 3-7, E-1
- synchronization, 5-7

CMOS

- See also* BIOS
- CMOS (W6) (figure), 3-1
- PC configuration options, 3-10, E-3
- system CMOS, 3-10, E-3

COM1

- connector signals, C-10
- location and pinouts, C-9

COM2

- connector signals, C-10
- location and pinouts, C-9

common questions, E-1

compatibility, A-3

compiler symbols for NI-VXI, 4-5

configuration

- CLK10 routing and termination, 3-5, 3-7
- controller/non-system controller, 3-5
- MITE EEPROM, 3-7
- trigger input termination, 3-5
- VXIpc 870 Series, 3-5, E-4

connectors, C-1

controller/non-system controller
configuration, 3-5

CPU

- bus factor, 3-12
- bus factor (W1, W3, W5, W7) (figure), 3-1
- bus speed, 3-11
- Pentium II, support of, 3-12

D

- debugging, 4-6
 - NI Spy, 4-6
 - VIC, 4-6
 - VISAIC, 4-6
- device interaction (software development), 4-2
- diagnostic resources, online, F-1
- dimensions, A-2
- driver software, 1-4
- DRV LED, B-3

E

- EEPROM, 3-7, 3-8
 - configuration, 3-5, 3-8
 - enable, Ethernet serial, 3-2
 - enable, Ethernet serial (figure), 3-1
 - fixing an invalid configuration, 3-8
 - power-on settings, 3-13
- electrostatic discharge, 2-1
- EMI, A-1
- Ethernet
 - address (figure), 3-1
 - and SCSI-3, 5-3
 - connector location and pinouts, C-8
 - connector signals, C-9
- Ethernet LEDs, B-3
 - 100B-T LED, B-3
 - LNK LED, B-3
 - RX/TX LED, B-3
- Ethernet serial EEPROM
 - enable (W1) (figure), 3-1
 - power-on settings, 3-13
- expansion
 - PCI, ISA, 5-4
- external clock, 5-7, C-17
- external SMBs, C-17

F

- FAIL LED, B-1
- flash memory
 - installing and removing a flash storage card (figure), 2-4
 - installing and removing in the VXIpc-873, 2-3
- flash protect (W17), 3-1
- flash protection, 3-12, 3-13
- front panel, C-1, C-2
 - connectors, C-1
 - thickness, C-2
- functional overview, 5-1
- functional shock, A-1
- fuse location (figure), 3-1
- fuse, main power, changing, 3-14
- fused power protection, 5-5

G

- GPIB
 - location and pinouts, connector signals, C-15
- GPIB mating connector, C-15

H

- hardware defaults, 3-1
 - (figure), 3-1
 - (table), 3-2
- hardware switches, accessing, 3-5

I

- IDE, E-2
- IEEE 488.2/HS488 interface, 5-4
- IEEE-1284, C-10
- IEEE-488.2, C-15
- installation, 2-1

installing

in slot other than Slot 0, E-2

instrument drivers, 1-5

interface status LEDs, B-1

ISA bus card, 5-4

J

jumper settings (table), 3-2

K

keyboard, C-6

adapter cable for, 2-2, E-2

connectors location and pinout, C-6

L

LabVIEW, 1-5

LabWindows/CVI, 1-5, 4-6

LEDs, B-1

100B-T LED, B-3

ACC LED, B-3

and system startup, B-2

board access, B-3

DRV LED, B-3

Ethernet, B-3

FAIL LED, B-1

indicators, B-1

LNK LED, B-3

ONLINE LED, B-1

PWROK LED, B-1

RX/TX LED, B-3

SCSI LED, B-3

SYSF LED, B-1

LNK LED, B-3

locator diagram, 3-1

M

main power fuse, changing, 3-14

memory

installing additional, 3-13

SO-DIMM sockets (figure), 3-1

SO-DIMMs from National Instruments
(note), 3-14

MITE Configuration Enable (S2) (figure), 3-1

MITE EEPROM

See also EEPROM

configuration, 3-7

MITE user configuration (S1) (figure), 3-1

mouse, 2-2, C-6

connectors location and pinout, C-6

MTBF, A-3

N

National Instruments Web support, F-1

NI Spy, 4-6

NI WatchDOG, 3-13, 5-4

NI-VISA

definition, 4-4

NI-VISA User Manual, location of (note), 4-4

NI-VXI

compiler symbols, 4-5

using, E-4

NI-VXI User Manual, location of (note), 4-4

NI-VXI/VISA

determining version, E-4

driver, 4-1

examples (table), 4-4

O

onboard jumper and switch settings
(table), 3-2

onboard logic, 3-7

ONLINE LED, B-1

online problem-solving and diagnostic
resources, F-1

operating system, re-installing, E-3
overview, 1-1

P

parallel port compatible connector, C-10
parallel port connector location and pinout, C-10
parallel port connector signals, C-11
parts locator diagram (figure), 3-1
PC CARD expansion, 5-3
PC configuration options, 3-9

- CPU bus factor, 3-12
- CPU bus speed, 3-11
- installing additional memory, 3-13
- SCSI termination, 3-10
- system CMOS, 3-10
- voltage monitor, 3-13

PCI card, 5-4
PIIX4, 5-4
ports

- COM, 2-2
- COM1, C-10
- COM2, C-10
- LPT, 2-2
- parallel, C-10

POSC (power-on self-configuration), 3-8
power monitor (W15) (figure), 3-1
power-on self-configuration (POSC), 3-8
problem-solving and diagnostic resources, online, F-1
processor, 5-2
programmable reset circuitry, 5-5
programming tools, 1-5
programming with VXI, 4-4
PWROK LED, B-1

R

RAM

SO-DIMMs from National Instruments
(note), 3-14

random vibration, A-1
real-time clock, 5-5
reinstalling operating system, E-3
relative humidity, A-1
Resman, 4-1, E-5

- when to run, E-3

RX/TX LED, B-3

S

SCSI

connector signals, C-13
location and pinouts, C-13
termination, 3-10
termination enable (figure), 3-1

SCSI BIOS, 5-5, E-2

SCSI compatible connector, C-13

SCSI LED, B-3

SCSI-3, 5-3

SDRAM, 5-2

serial number

(figure), 3-1

of VXIpc embedded computers, E-4

serial port mating connector, C-9

signal characteristics, C-18

for SMB and speaker connections, C-18

Slot 0, 5-6

as system controller, 3-6

slot requirements, A-2

SMB connectors

location, pinouts, connector signals, C-17

mating connector, C-17

SO-DIMM sockets (figure), 3-1

SO-DIMMs from National Instruments

(note), 3-14

software default settings, 3-3

- software development, 4-1 to 4-6
 - configuration
 - T&M Explorer, Resman, 4-1
 - device interaction, 4-2
 - NI-VXI/VISA examples (table), 4-4
 - programming with NI-VXI or NI-VISA, 4-4
 - programming with VXI, 4-4
 - using VME, 4-5
 - utilities, 4-1
 - debugging, 4-6
 - NI Spy, 4-6
 - VIC, 4-6
 - VISAIC, 4-6
- software tools, 1-5
- software-related resources, F-2
- speaker, C-18
 - connection location, C-18
- specifications, A-1 to A-4
 - environmental, A-1
 - physical, A-2
 - power requirement, A-2
 - requirements, A-1
 - VMEbus capability codes, A-3
 - VXIpc 870 Series, A-1
- Super IO, 5-4
- SVGA, 5-3
 - connector location and pinout, C-7
 - connector signals, C-7
- switch settings (table), 3-2
- switches
 - accessing, 3-5
- SYSF LED, B-1
- system clock, 3-6, 5-7
- system CMOS, 3-10, E-3
- system controller
 - and slot configuration, 3-6
- system controller/non-system controller, 2-2, 3-6
- system testing, E-5

T

- T&M Explorer, 4-1
 - using, 4-2
- technical support resources, F-1
- telephone support, F-2
- temperature, A-1
- trigger input termination, 3-7
 - configuration, 3-5
- TTL trigger input and output, C-17

U

- Universal Serial Bus (USB), C-12
- USB
 - connector signals, C-12
 - connectors, C-12
 - location and pinouts, C-12

V

- VIC, 4-6
- VIDEO BIOS, 5-5
- VISAIC, 4-6
- VME
 - adding devices, E-4
 - using, 4-5
- VMEbus capability codes, A-3
- voltage monitor, 3-13
- VXI
 - interrupts, 5-7
 - keying class, A-3
 - trigger lines, 5-7
 - voltage monitor circuitry, 5-5
- VXIbus, 5-6
 - configuration space, A-1
 - connectors location and pinout, C-19
 - DMA transfers to and from VXI, 5-6
 - interface status LEDs, B-1
 - P1 connector signals, C-19
 - P2 connector signals, C-20

- VXI addressing, 5-6
- VXI Slot 0 functionality, 5-6
- VXI-MXI-2, 3-4
 - software default settings, 3-3
 - T&M Explorer device tab default settings (table), 3-4
 - T&M Explorer MXI-2 bus tab default settings (table), 3-5
 - T&M Explorer VXI bus tab default settings (table), 3-4
- VXIpc 870 Series
 - application software, 1-5
 - block diagram, 5-2
 - COM1 location and pinouts, C-9
 - COM2 location and pinouts, C-9
 - configuration, E-4
 - configuring, 3-5
 - connectors, C-1
 - CPU
 - bus factor, 3-12
 - bus speed, 3-11
 - Pentium II, support of, 3-12
 - driver software, 1-4
 - Ethernet
 - connector location and pinouts, C-8
 - serial EEPROM power-on settings, 3-13
 - flash protection, 3-12, 3-13
 - front panel, C-1
 - functional overview, 5-1
 - GPIO location and pinouts, connector signals, C-15
 - hardware defaults (table), 3-2
 - IEEE-1284, C-10
 - initializing, E-5
 - installation, 2-1
 - installing in slot other than Slot 0, E-2
 - keyboard adapter cable, E-2
 - keyboard and mouse connectors, location and pinout, C-6
 - overview, 1-1

- SCSI location and pinouts, C-13
- specifications, A-1
- system testing, E-5
- Universal Serial Bus (USB), C-12
- using NI-VXI, E-4
- VXI interrupts, 5-7
- VXI Slot 0 functionality, E-2
- VXI trigger lines, 5-7
- VXIpc T&M Explorer
 - device tab default settings (table), 3-3
 - PCI tab default settings (table), 3-3
 - shared memory tab default settings (table), 3-3
- VXIpc-871
 - front panel layout and dimensions, C-2
- VXIpc-872
 - front panel layout and dimensions, C-3
 - height of plug-in boards, D-1
 - I/O board dimensions for expansion slot, D-1
 - I/O expansion boards, modifying and installing, D-1
 - installing an I/O board, D-2
- VXIpc-873
 - front panel layout and dimensions, C-4, C-5
 - I/O expansion boards, modifying and installing, D-1
 - installing and removing flash memory, 2-3

W

- WatchDOG, 3-13, 5-4
- Web support from National Instruments
 - online problem-solving and diagnostic resources, F-1
 - software-related resources, F-2
- weight, A-2
- worldwide technical support, F-2