

## COMPREHENSIVE SERVICES

We offer competitive repair and calibration services, as well as easily accessible documentation and free downloadable resources.

## SELL YOUR SURPLUS

We buy new, used, decommissioned, and surplus parts from every NI series. We work out the best solution to suit your individual needs.

 Sell For Cash    Get Credit    Receive a Trade-In Deal

## OBSOLETE NI HARDWARE IN STOCK & READY TO SHIP

We stock **New**, **New Surplus**, **Refurbished**, and **Reconditioned** NI Hardware.



*Bridging the gap between the manufacturer and your legacy test system.*

 1-800-915-6216

 [www.apexwaves.com](http://www.apexwaves.com)

 [sales@apexwaves.com](mailto:sales@apexwaves.com)

*All trademarks, brands, and brand names are the property of their respective owners.*

**Request a Quote**

 **CLICK HERE**

**cFP-2000**

# FieldPoint Operating Instructions

## cFP-RLY-425

### Eight-Channel SPST Relay Module

These operating instructions describe how to install and use the National Instruments cFP-RLY-425 relay module. For information about configuring and accessing the cFP-RLY-425 over a network, refer to the user manual for the FieldPoint network module you are using.

## Features

---

The cFP-RLY-425 is a Compact FieldPoint relay output module with the following features:

- Eight single-pole single-throw (SPST) relay channels
- Switches up to 5 A at 18 VDC or 150 VAC, 0.2 A at 125 VDC, or 3 A at 250 VAC
- -40 to 70 °C operation
- 250 V<sub>rms</sub> CAT II continuous channel-to-channel and channel-to-ground isolation, verified by 2,300 V<sub>rms</sub> 1 minute dielectric withstand test
- Hot swappable

## Power Requirement

---

The cFP-RLY-425 is powered by the FieldPoint network module through the backplane bus. The cFP-RLY-425 requires up to 1.45 W of power,<sup>1</sup> which may limit the number of I/O modules that you can connect to a single network module.

Before you configure a FieldPoint system that uses a cFP-RLY-425 module, calculate the total power consumption of the I/O modules on the FieldPoint bank. Power requirements are listed in the *Specifications* sections of the operating instructions for each I/O module. The network module user manual lists the maximum

---

<sup>1</sup> 1.45 W is the maximum power requirement. Most applications require less power.

power that the network module can supply. Make sure the total power requirement for all of the I/O modules in the bank is less than the maximum power available from the network module.

Suppose you have a bank with a cFP-2000 network module, three cFP-RLY-425 modules, and five cFP-DI-300 modules. The cFP-2000 can supply up to 9 W. The cFP-RLY-425 requires up to 1.45 W, and the cFP-DI-300 requires 0.185 W. Three cFP-RLY-425 modules and five cFP-DI-300 modules require a total of 5.28 W:

$$3(1.45 \text{ W}) + 5(0.185 \text{ W}) = 5.28 \text{ W}$$

This power requirement is less than the 9 W maximum.

## Installing the cFP-RLY-425

---

The cFP-RLY-425 mounts on a Compact FieldPoint backplane (cFP-BP-*x*), which provides operating power to the module. Installing the cFP-RLY-425 onto a powered backplane does not disrupt the operation of the bank.

To install the cFP-RLY-425, refer to Figure 1 and complete the following steps:

1. Align the captive screws on the cFP-RLY-425 with the holes on the backplane. The alignment keys on the cFP-RLY-425 prevent backward insertion.
2. Press firmly to seat the cFP-RLY-425 on the backplane.
3. Using a number 2 Phillips screwdriver with a shank of at least 64 mm (2.5 in.) length, tighten the captive screws to 1.1 N · m (10 lb · in.) of torque. The nylon coating on the screws prevents them from loosening.

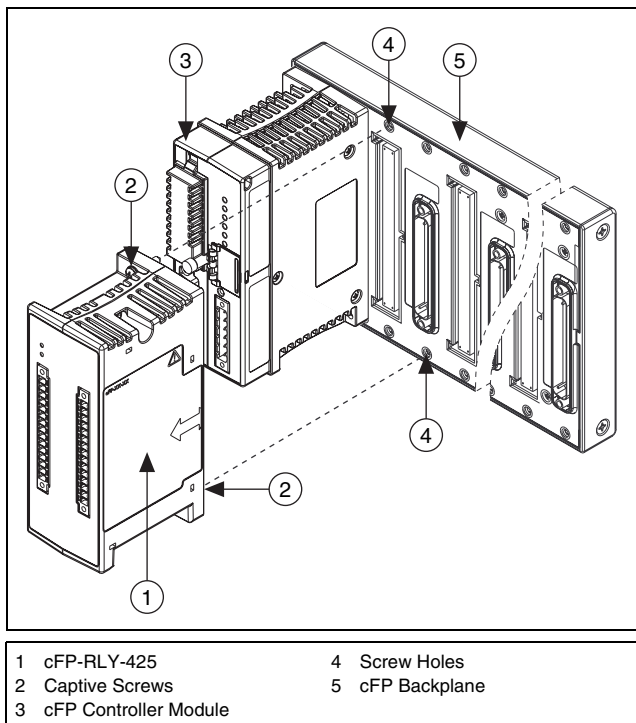

**Figure 1.** Installing the cFP-RLY-425

## Mounting the System Upright

To ensure maximum cooling efficiency, mount the Compact FieldPoint system so that the I/O module vents are at the top and bottom as shown in Figure 2.

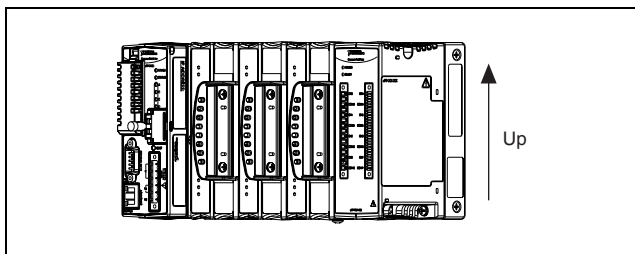

**Figure 2.** Mounting the System Upright

## Wiring the cFP-RLY-425

Each relay channel of the cFP-RLY-425 has two terminals, CHx and COMx.



**Caution** Ensure that *hazardous voltage* wiring is performed only by qualified personnel adhering to local electrical standards. A hazardous voltage is a voltage greater than 42.4 V<sub>peak</sub> or 60 VDC.

The screw terminals for the CHx and COMx pins are on two detachable screw-terminal connectors. Table 1 lists the terminal assignments for the signals of each channel.

**Table 1.** Terminal Assignments

Channel	Terminal Numbers	
	CHx	COMx
0	L1	L3
1	L5	L7
2	L9	L11
3	L13	L15
4	R15	R13
5	R11	R9
6	R7	R5
7	R3	R1

Note that screw terminals 1–15 on the left connector are for channels 0–4, and screw terminals 15–1 on the right connector are for channels 4–7. Figure 3 shows how to orient the two connectors with respect to the cFP-RLY-425.

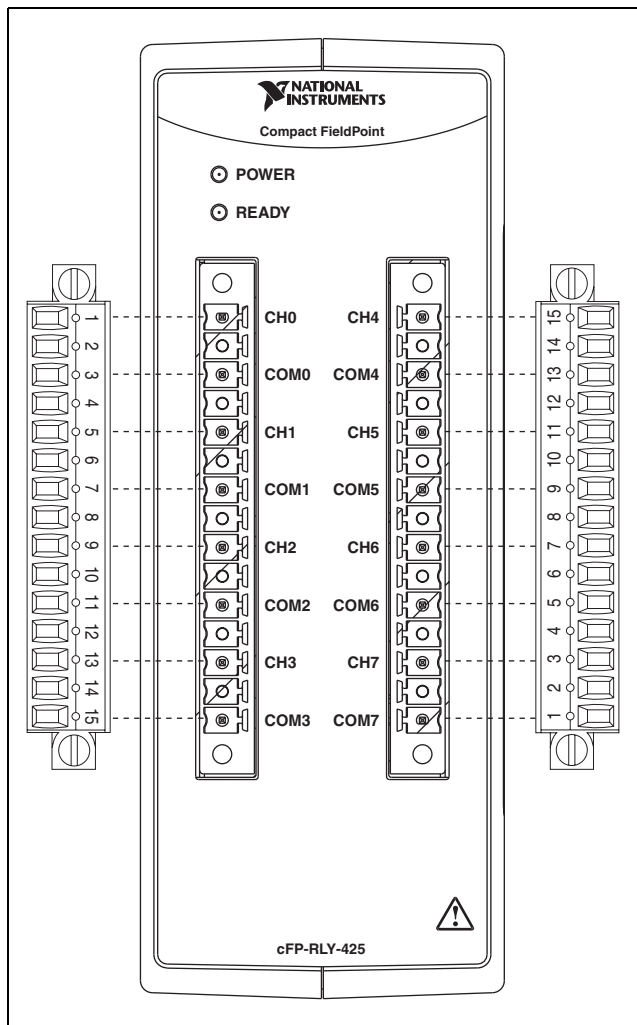

**Figure 3.** cFP-RLY-425 Screw-Terminal Connectors

Wire the screw terminals and place the connector in the shell as shown in Figure 4. Make sure that you use the half of the shell with the strain-relief screw holes.

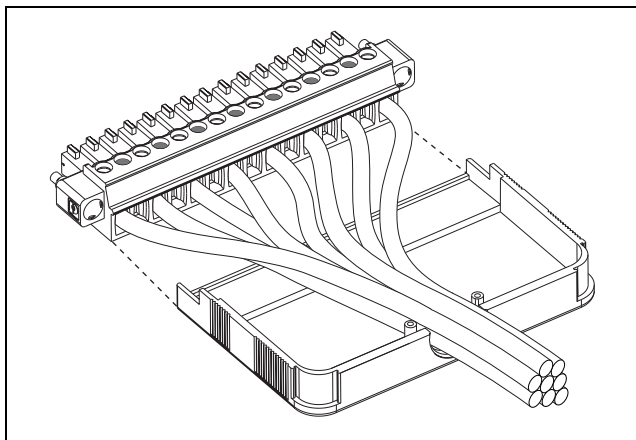

**Figure 4.** Placing the Screw-Terminal Connector in the Shell

Install the strain-relief bar as shown in Figure 5.

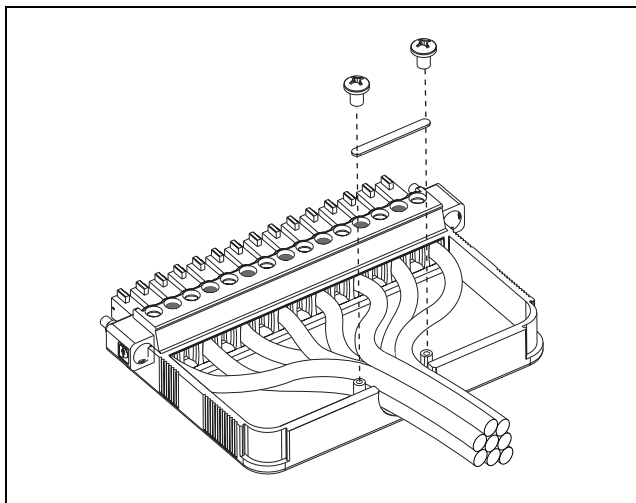

**Figure 5.** Installing the Strain-Relief Bar on the Connector Shell

Close the shell as shown in Figure 6.

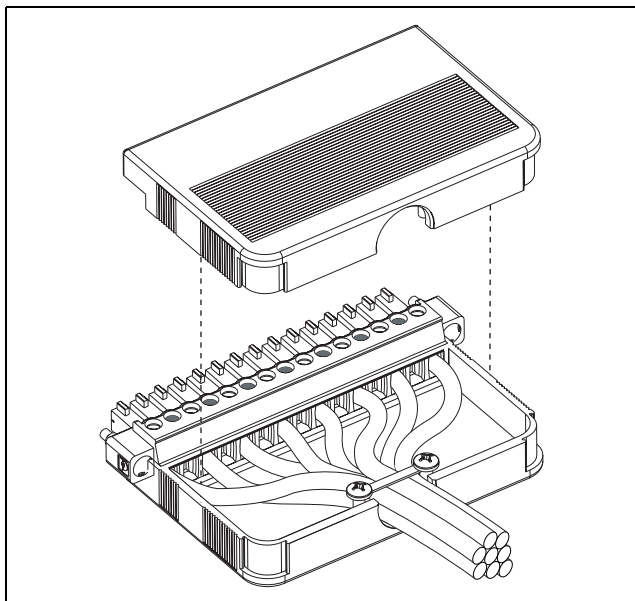

**Figure 6.** Closing the Connector Shell

Install the labels and label covers as shown in Figure 7.

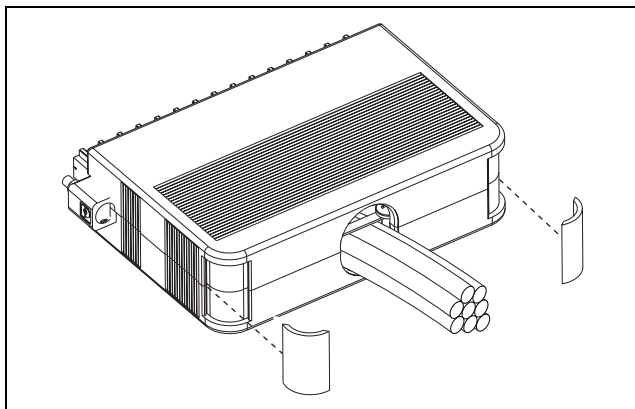

**Figure 7.** Installing the Label Covers on the Connector



Insert the connector into the cFP-RLY-425 as shown in Figure 8, then tighten both flange screws on the connector.

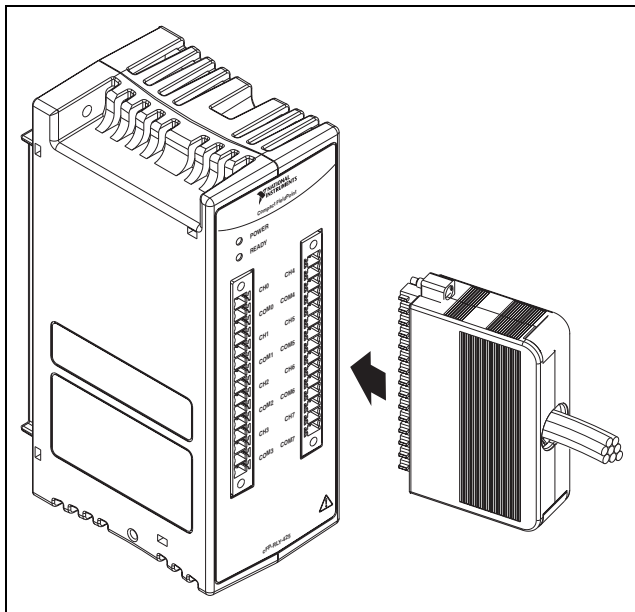

**Figure 8.** Installing One Assembled Screw-Terminal Connector

## Connecting Loads to the cFP-RLY-425

Wire a load to a channel of the cFP-RLY-425 as shown in Figure 9. Install a 5 A, 250 V maximum, fast-acting fuse (F 5 A L 250V) at the COMx terminal to protect the module and the load from damage.

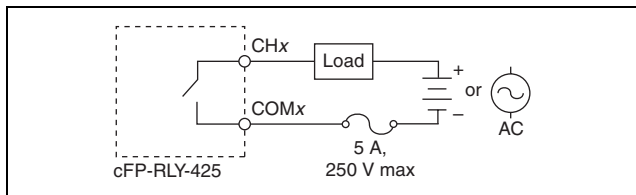

**Figure 9.** Connecting a Load to One Channel of the cFP-RLY-425

The cFP-RLY-425 has eight SPST (single-pole single-throw) electromechanical relays. The power-up state is OFF (open) to ensure safe installation. In the ON state, the CH<sub>x</sub> and COM<sub>x</sub> relay contacts connect to form a short circuit. In the ON state, there is an effective resistance of up to 50 mΩ between the CH<sub>x</sub> and COM<sub>x</sub> terminals, which causes a voltage drop.<sup>1</sup> For example, if the current is 5 A, the voltage drop across the CH<sub>x</sub> and COM<sub>x</sub> terminals can be as high as 0.25 V.

The amount of current the relay can switch depends on the voltage, the type of load, and the ambient temperature. Refer to the [Specifications](#) section for more information.

## Protecting Contacts for Inductive Loads

---

When inductive loads are connected to the relays, a large counter-electromotive force may occur at relay switching time because of the energy stored in the inductive load. These flyback voltages can severely damage the relay contacts and greatly shorten the life of the relay.

It is best to limit flyback voltages by installing a flyback diode across an inductive DC load or a metal oxide varistor (MOV) across an inductive AC load.

In addition, the cFP-RLY-425 has internal protection MOVs to prevent excessively high voltage from being applied across the contacts. The MOVs are located between the CH<sub>x</sub> and COM<sub>x</sub> contacts of each relay. However, National Instruments recommends the use of a protection circuit across each inductive load. The flyback protection causes a small leakage current, which is detailed in the [Specifications](#) section.

Refer to the *NI Switches Help* for information about selecting and installing contact protection circuits. Go to [ni.com/manuals](http://ni.com/manuals) and select **Current Manual Revisions»Switches»Software»NI Switches Help**.

## Status Indicators

---

After you install the cFP-RLY-425 onto a backplane and apply power to the network module, the green **POWER** indicator lights and the cFP-RLY-425 informs the network module of its presence. When the network module recognizes the cFP-RLY-425, it sends

---

<sup>1</sup> At the end of relay life, the path resistance rises rapidly above 1 Ω.

initial configuration information to the cFP-RLY-425. After the cFP-RLY-425 receives this initial information, the green **READY** indicator lights and the module is in normal operating mode.

## Isolation and Safety Guidelines

---



**Caution** Read the following information before attempting to connect the cFP-RLY-425 to any circuits that may contain hazardous voltages.

This section describes the isolation of the cFP-RLY-425 and its compliance with international safety standards. The field wiring connections are isolated from the backplane and the inter-module communication bus. The isolation barriers in the module provide 250 V<sub>rms</sub> Measurement Category II continuous isolation, verified by 2,300 V<sub>rms</sub>, 1 minute dielectric withstand test. The cFP-RLY-425 provides *double insulation* (compliant with IEC 61010-1) for working voltages of 250 V<sub>rms</sub><sup>1</sup>. Safety standards (such as those published by UL and IEC) require the use of double insulation between hazardous voltages and any human-accessible parts or circuits.

*Never* try to use any isolation product between human-accessible parts (such as DIN rails or monitoring stations) and circuits that can be at hazardous potentials under normal conditions, unless the product is specifically designed for such an application, as is the cFP-RLY-425.

Even though the cFP-RLY-425 is designed to handle applications with hazardous potentials, follow these guidelines to ensure a safe system:

- You *must* connect the protective earth (PE) ground terminal on the cFP-BP-*x* backplane to the system safety ground. The backplane PE ground terminal has the following symbol stamped beside it: . Connect the backplane PE ground terminal to the system safety ground using 14 AWG (1.6 mm) wire with a ring lug. Use the 5/16 in. panhead screw shipped with the backplane to secure the ring lug to the backplane PE ground terminal.

---

<sup>1</sup> *Working voltage* is defined as the signal voltage plus the common-mode voltage. *Common-mode voltage* is the voltage of the module with respect to ground.

- The cFP-RLY-425 is a UL Recognized component. The entire Compact FieldPoint system must be installed in a UL Listed, suitably rated NEMA or IP enclosure for safe use.

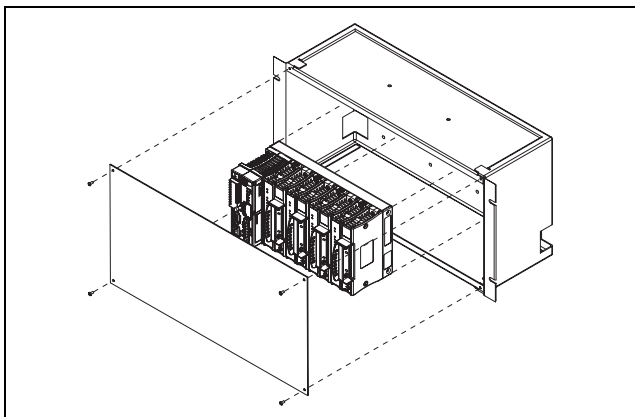

**Figure 10.** Installing the Compact FieldPoint System in an Enclosure

- As with any hazardous voltage wiring, make sure that all wiring and connections meet applicable electrical codes and commonsense practices. Mount terminal bases and backplanes in an area, position, or cabinet that prevents accidental or unauthorized access to wiring that carries hazardous voltages.
- Do *not* use the cFP-RLY-425 as the only isolating barrier between human contact and working voltages higher than  $250 V_{\text{rms}}$ .
- Operate the cFP-RLY-425 only at or below Pollution Degree 2. Pollution Degree 2 means that only nonconductive pollution occurs in most cases. Occasionally, however, condensation can cause temporary conductivity.
- Do *not* operate FieldPoint products in an explosive atmosphere or where there may be flammable gases or fumes. If you need to operate FieldPoint products in such an environment, the FieldPoint products *must* be in a suitably rated enclosure.
- Operate the cFP-RLY-425 at or below Measurement Category II. Measurement Category II is for measurements performed on circuits directly connected to the low-voltage installation. This category refers to local-level distribution, such as that provided by a standard wall outlet. Do not use this module with voltages in Measurement Categories III or IV.

# Specifications

The following specifications are typical for a range of  $-40$  to  $70$  °C unless otherwise noted. All specifications are subject to change without notice.

## Relay Characteristics

- Number of channels ..... 8
- Relay type ..... SPST, nonlatching, normally open
- Maximum switching capacity (resistive load)
  - At 250 VAC ..... 3 A
  - At 150 VAC ..... 5 A
  - At 0 to 18 VDC ..... 5 A
  - At 125 VDC ..... 0.2 A
- Maximum switching power on each channel..... 750 VA, 90 W
- Minimum switching load..... 1 mA at 5 VDC
- Maximum current through all channels.....  $200 \text{ A}^2$

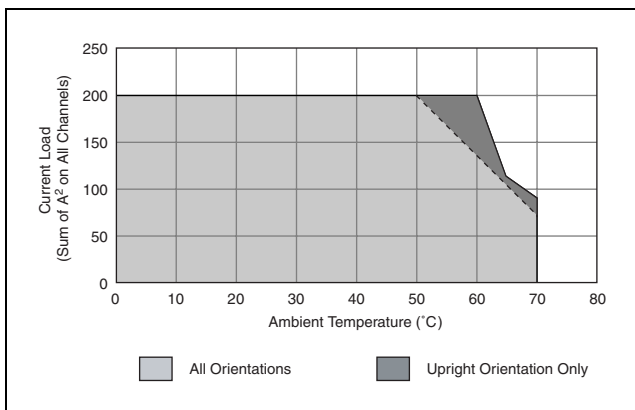

**Figure 11.** Maximum Current on All Channels by Ambient Temperature

Calculate the maximum current as

$$\sum_{n=0}^7 (I_n)^2$$

Example 1. If eight channels carry 5 A each, the total current is  $8(5 \text{ A})^2 = 200 \text{ A}^2$ . As shown in Figure 11, the module can output this total current with an ambient temperature up to 60 °C.

Example 2. If two channels carry 5 A each and six channels carry 2 A each, the total current is  $2(5 \text{ A})^2 + 6(2 \text{ A})^2 = 74 \text{ A}^2$ . The module can output this total current with an ambient temperature up to 70 °C.

Initial path resistance ..... <50 mΩ



**Note** DC path resistance typically remains low for the life of the relay. At the end of relay life, the path resistance rises rapidly above 1 Ω. Load ratings apply to relays used within the specification before the end of relay life.

Off-state leakage current

At 125 VDC ..... 0.03 μA

At 250 VAC ..... 2 μA

Expected relay life

Mechanical .....  $2 \times 10^7$  operations

Electrical

At 5 A, 30 VDC .....  $1.5 \times 10^5$  operations

At 3 A, 120 VAC .....  $1.5 \times 10^5$  operations

At 5 A, 250 VAC .....  $3 \times 10^4$  operations

Recommended cycle rate

With up to 3 A load ..... 1 s ON, 1 s OFF

With 3 A or greater load ..... 3 s ON, 3 s OFF

Relay operate time ..... <10 ms

Relay release time ..... <7 ms

Contact bounce time ..... <1 ms

Contact material ..... Gold-plated silver alloy

## Physical

Indicators .....	Green <b>POWER</b> and <b>READY</b> indicators
Weight.....	201 g (7.1 oz)

## Power Requirements

Power from network module .....	1.45 W at -40 to 70 °C
---------------------------------	------------------------

## Isolation Voltage

Channel-to-ground and channel-to-channel isolation	
Continuous .....	250 V <sub>rms</sub> , Measurement Category II
Dielectric withstand.....	2,300 V <sub>rms</sub> , 1 minute

## Environmental

FieldPoint modules are intended for indoor use only. For outdoor use, they must be mounted inside a sealed enclosure.

Operating temperature <sup>1</sup> .....	-40 to 70 °C
Storage temperature .....	-55 to 85 °C
Humidity .....	10 to 85% RH, noncondensing
Maximum altitude.....	2,000 m; at higher altitudes the isolation voltage ratings must be lowered
Pollution Degree .....	2

## Safety

This product is designed to meet the requirements of the following standards of safety for electrical equipment for measurement, control, and laboratory use:

- IEC 61010-1, EN 61010-1
- UL 61010-1
- CAN/CSA-C22.2 No. 61010-1

For UL, hazardous location, and other safety certifications, refer to the product label or visit [ni.com/certification](http://ni.com/certification), search by

---

<sup>1</sup> Refer to Figure 11 for maximum current on all channels.

model number or product line, and click the appropriate link in the Certification column.

## Electromagnetic Compatibility

Emissions.....	EN 55011 Class A at 10 m FCC Part 15A above 1 GHz
Immunity.....	EN 61326:1997 + A2:2001, Table 1

CE, C-Tick, and FCC Part 15 (Class A) Compliant

## CE Compliance

This product meets the essential requirements of applicable European Directives, as amended for CE marking, as follows:

Low-Voltage Directive (safety).....	73/23/EEC
Electromagnetic Compatibility Directive (EMC) .....	89/336/EEC



**Note** Refer to the Declaration of Conformity (DoC) for this product for any additional regulatory compliance information. To obtain the DoC for this product, visit [ni.com/certification](http://ni.com/certification), search by model number or product line, and click the appropriate link in the Certification column.

## Where to Go for Support

---

For more information about setting up the FieldPoint system, refer to these National Instruments documents:

- FieldPoint network module user manual
- Other FieldPoint I/O module operating instructions
- FieldPoint terminal base and connector block operating instructions

Go to [ni.com/support](http://ni.com/support) for the most current manuals, examples, and troubleshooting information.

National Instruments corporate headquarters is located at 11500 North Mopac Expressway, Austin, Texas, 78759-3504. National Instruments also has offices located around the world to help address your support needs. For telephone support in the United States, create your service request at [ni.com/support](http://ni.com/support) and follow



the calling instructions or dial 512 795 8248. For telephone support outside the United States, contact your local branch office:

Australia 1800 300 800, Austria 43 0 662 45 79 90 0,  
Belgium 32 0 2 757 00 20, Brazil 55 11 3262 3599,  
Canada 800 433 3488, China 86 21 6555 7838,  
Czech Republic 420 224 235 774, Denmark 45 45 76 26 00,  
Finland 385 0 9 725 725 11, France 33 0 1 48 14 24 24,  
Germany 49 0 89 741 31 30, India 91 80 51190000,  
Israel 972 0 3 6393737, Italy 39 02 413091,  
Japan 81 3 5472 2970, Korea 82 02 3451 3400,  
Lebanon 961 0 1 33 28 28, Malaysia 1800 887710,  
Mexico 01 800 010 0793, Netherlands 31 0 348 433 466,  
New Zealand 0800 553 322, Norway 47 0 66 90 76 60,  
Poland 48 22 3390150, Portugal 351 210 311 210,  
Russia 7 095 783 68 51, Singapore 1800 226 5886,  
Slovenia 386 3 425 4200, South Africa 27 0 11 805 8197,  
Spain 34 91 640 0085, Sweden 46 0 8 587 895 00,  
Switzerland 41 56 200 51 51, Taiwan 886 02 2377 2222,  
Thailand 662 278 6777, United Kingdom 44 0 1635 523545

National Instruments, NI, ni.com, and LabVIEW are trademarks of National Instruments Corporation. Refer to the *Terms of Use* section on [ni.com/legal](http://ni.com/legal) for more information about National Instruments trademarks. Other product and company names mentioned herein are trademarks or trade names of their respective companies. For patents covering National Instruments products, refer to the appropriate location: **Help»Patents** in your software, the `patents.txt` file on your CD, or [ni.com/patents](http://ni.com/patents).

© 2005 National Instruments Corp. All rights reserved.