

## COMPREHENSIVE SERVICES

We offer competitive repair and calibration services, as well as easily accessible documentation and free downloadable resources.

## SELL YOUR SURPLUS

We buy new, used, decommissioned, and surplus parts from every NI series. We work out the best solution to suit your individual needs.

 Sell For Cash    Get Credit    Receive a Trade-In Deal

## OBSOLETE NI HARDWARE IN STOCK & READY TO SHIP

We stock **New, New Surplus, Refurbished, and Reconditioned** NI Hardware.



*Bridging the gap between the manufacturer and your legacy test system.*

 1-800-915-6216

 [www.apexwaves.com](http://www.apexwaves.com)

 [sales@apexwaves.com](mailto:sales@apexwaves.com)

*All trademarks, brands, and brand names are the property of their respective owners.*

**Request a Quote**

 **CLICK HERE**

**cFP-2020**

# FieldPoint™ Operating Instructions

## Compact FieldPoint Accessories

This document describes the wiring, mounting, and data storage accessories available for use with National Instruments Compact FieldPoint. To search for parts listed in this document, go to [ni.com](http://ni.com) and enter the part number in the Search field. For accessories not listed in this document, refer to the *Distributed I/O* section of the NI catalog.

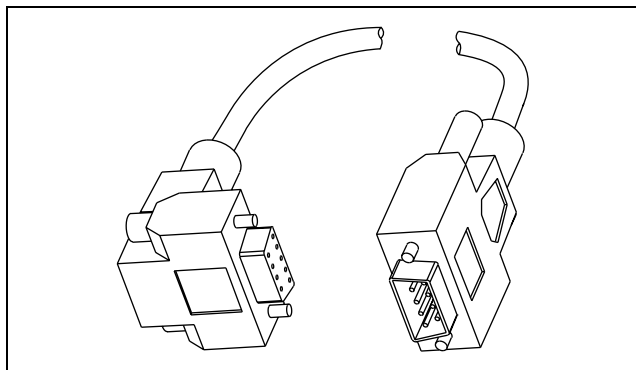
### cFP-20xx Controller Wiring Accessories

---

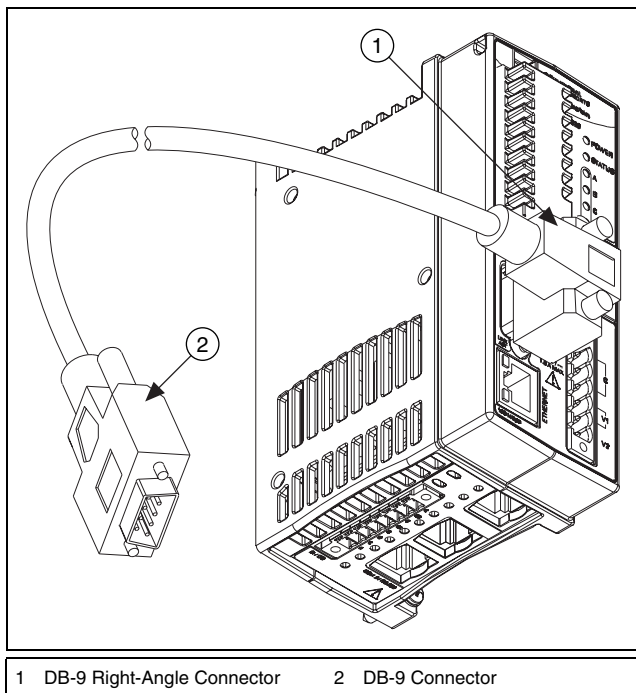
NI offers several accessories for connecting to the serial ports on the cFP-20xx controller.

#### DB-9 Right-Angle Cable for RS-232 Serial Port

The Compact FieldPoint RS-232 serial cable, part number 189284-02, is a DB-9 female to DB-9 male cable adapter for use with COM 1 on the cFP-20xx controller. The right-angle connector is well suited for low-profile applications with limited space in front of the controller.



**Figure 1.** Compact FieldPoint DB-9 Right-Angle Cable Adapter for COM 1



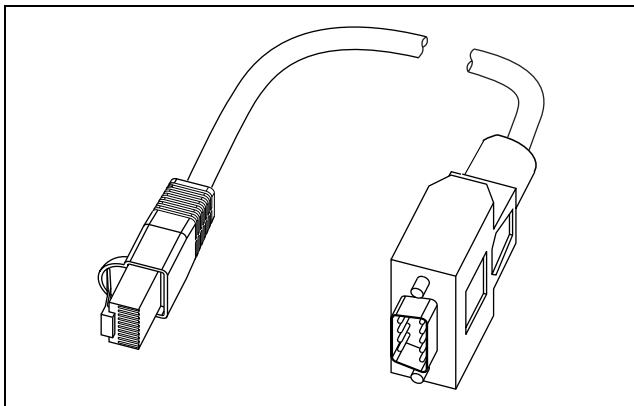
**Figure 2.** DB-9 Right-Angle Cable Adapter Connected to COM 1

The Compact FieldPoint DB-9 cable adapter cannot be used with the Compact FieldPoint rack-mount kit. Refer to the *Serial Cables* section of the NI catalog or to [ni.com](http://ni.com) for other DB-9 serial cables that you can use with a rack-mounted Compact FieldPoint system.

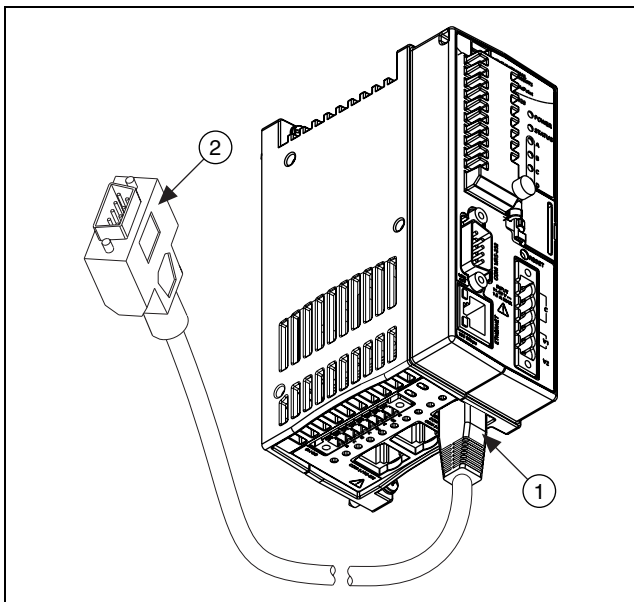
## Modular-Plug Cable Adapters for Serial Ports

NI offers several wiring accessories for use with COM 2, COM 3, and COM 4 on the cFP-20xx controller. COM 2 and COM 3 are RS-232 serial ports and COM 4 is an RS-485 serial port. All three ports use modular jacks. The modular jacks are not compatible with Ethernet cables.

Part numbers 182845-01, -02, and -03 are modular plug to DB-9 cable adapters in 1, 2, and 3 m lengths.



**Figure 3.** Compact FieldPoint Modular Plug to DB-9 Serial Cable Adapter

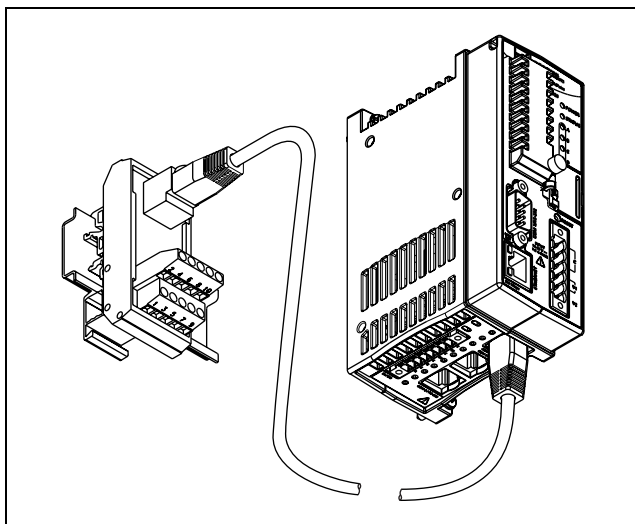


1 Modular Jack Connector

2 DB-9 Connector

**Figure 4.** DB-9 Cable Adapter Connected to COM 4

Part number 778674-01 is a DIN rail-mountable screw terminal adapter consisting of a modular plug serial cable and a 10-position screw terminal block. You can use it with COM 2, COM 3, and COM 4 on the cFP-20xx. It is especially useful for connecting termination resistors to COM 4, the RS-485 port.

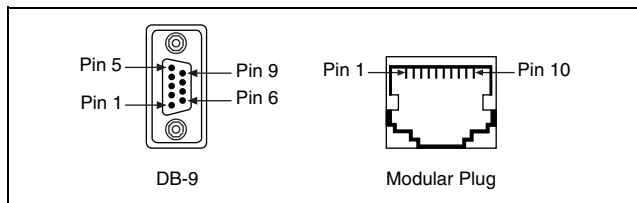


**Figure 5.** Compact FieldPoint DIN Rail-Mountable Terminal Block

Refer to the *Serial Cables* section of the NI catalog or to [ni.com](http://ni.com) for other serial cables that you can use with Compact FieldPoint controllers.

## Signal Assignments for Serial Cable Adapters

Figure 6 shows the locations of the pins on the DB-9 and modular plug connectors.



**Figure 6.** Pins on DB-9 and Modular Plug Connectors

Table 1 lists the pins on the cFP-20xx serial cable adapters and the RS-232 and RS-485 signals assigned to them.

**Table 1.** Compact FieldPoint Serial Cable Pin Descriptions

Connector Pins		Serial Signal Assignments	
DB-9 Pin	Modular Plug Pin or Screw Terminal	RS-232 Signal	RS-485 Signal
1	10	DCD	GND
2	9	RX	CTS+ (HSI+)
3	8	TX	RTS+ (HSO+)
4	7	DTR	RXD+
5	6	GND	RXD-
6	5	DSR	CTS- (HSI-)
7	4	RTS	RTS- (HSO-)
8	3	CTS	TXD+
9	2	RI	TXD-
—	1	No Connect	No Connect

## I/O Connector Cable Adapters

NI offers several cable adapters for use with the 37-pin I/O connectors on the Compact FieldPoint backplane.



**Caution** Compact FieldPoint I/O connector cable adapters are for use only with nonhazardous voltages.<sup>1</sup> For hazardous voltage wiring, use a cFP-CB-1 or cFP-CB-3 connector block and follow local electrical standards. Refer to the *cFP-CB-1 and cFP-CB-3 Operating Instructions* for information about the Compact FieldPoint connector blocks.



**Caution** Use external fuses with the I/O connector cable adapters to ensure that signals on the wires do not exceed current ratings. The 26 AWG wires on the I/O connector

<sup>1</sup> Nonhazardous voltage is voltage below 30 V<sub>rms</sub>/42.4 V peak or 60 VDC.

cables are rated for up to 1 A. The 18 AWG external power wires are rated for up to 4 A.

Table 2 lists the wire colors that correspond to the 37 pins on the Compact FieldPoint I/O connectors. Signal names in parentheses indicate signals common to all Compact FieldPoint I/O modules. For all other signals, refer to the I/O module operating instructions.

**Table 2.** 37-Pin Cable Adapter Wire Identification

<b>37-Pin Connector</b>	<b>26 AWG Wire<sup>1</sup></b>
1	Black
2	Brown
3	Red
4	Orange
5	Yellow
6	Green
7	Blue
8	Purple
9	Gray
10	White
11	Pink
12	Light Green
13	Black/White
14	Brown/White
15	Red/White
16	Orange/White
17	Green/White
18	Blue/White
19	Purple/White
20	Red/Black
21	Orange/Black
22	Yellow/Black
23	Green/Black

**Table 2.** 37-Pin Cable Adapter Wire Identification (Continued)

<b>37-Pin Connector</b>	<b>26 AWG Wire<sup>1</sup></b>
24	Gray/Black
25	Pink/Black
26	Pink/Red
27	Pink/Blue
28	Pink/Green
29	Light Blue
30	Light Blue/Black
31	Light Blue/Red
32	Light Blue/Blue
33 (V)	Light Blue/Green
34 (V)	Gray/Red
35 (C)	Gray/Green
36 (C)	Purple/Black
37 (CJC)	Blue/Black
<sup>1</sup> 1 A max. Install external fuses to ensure that signals do not exceed the current limit.	

Table 3 lists additional connections on the cable adapters with external power wires.

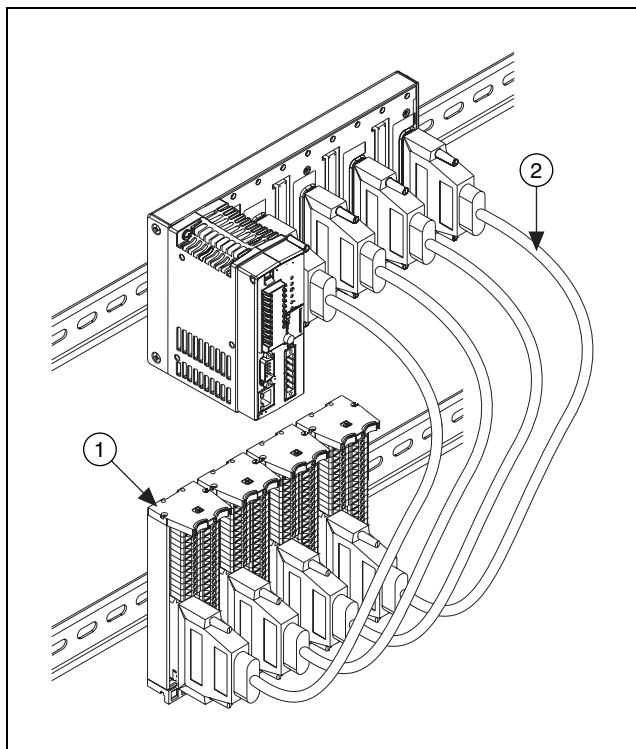
**Table 3.** 37-Pin Cable Adapter External Power Wires Identification

<b>37-Pin Connector</b>	<b>18 AWG External Power Wires<sup>1</sup></b>
33 (V)	Red
34 (V)	
35 (C)	Black
36 (C)	
<sup>1</sup> 4 A max. Install external fuses to ensure that signals do not exceed the current limit.	



## I/O Cable Adapters for Use with DIN Rail–Mounted Terminal Blocks

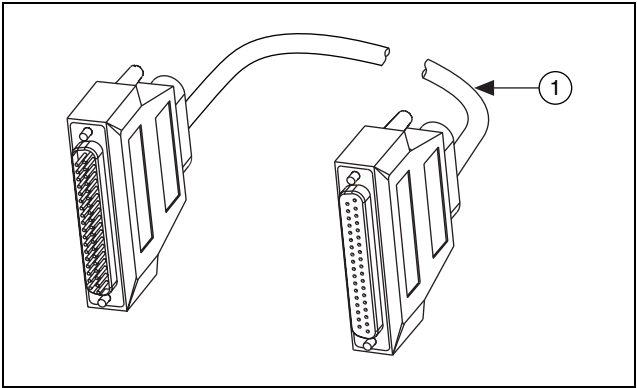
DIN rail–mounted terminal blocks provide easy access to wiring. NI offers two DIN rail–mounted terminal blocks, part numbers 778672-01 and 778673-01. Figure 7 shows a Compact FieldPoint bank connected to four terminal blocks.



- |   |                                   |   |                            |
|---|-----------------------------------|---|----------------------------|
| 1 | DIN Rail–Mounted Terminal Blocks, | 2 | I/O Connector Cable (1 m), |
|   | Part Number 778672-01             |   | Part Number 778621-01      |

**Figure 7.** Compact FieldPoint System with DIN Rail–Mounted Terminal Blocks

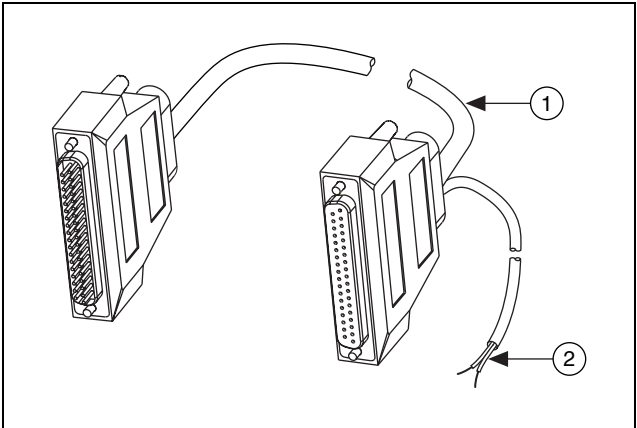
Part numbers 778621-01 and 778621-02 are 37-pin male to 37-pin female cable adapters in 1 and 2 m lengths, respectively. They are designed for connecting directly to the DIN rail–mounted terminal blocks as shown in Figure 7.



1 26 AWG, 1 A Max

**Figure 8.** 37-Pin I/O Connector Cable, Part Numbers 778621-01 and 778621-02

Part number 189985-01 is a 37-pin male to 37-pin female cable adapter of 1 m length with external power wires.

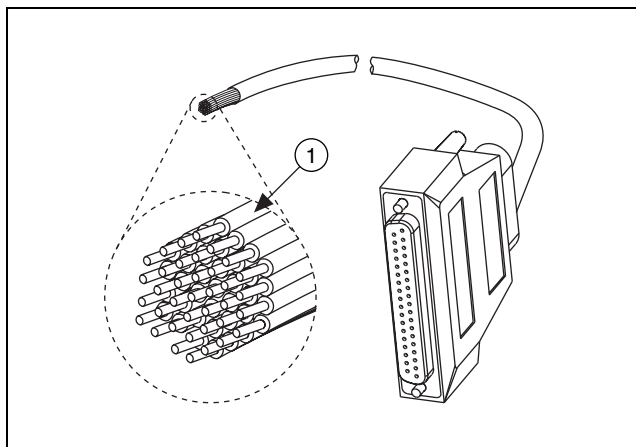


1 26 AWG, 1 A Max      2 To Power Supply, 18 AWG, 4 A Max

**Figure 9.** 37-Pin I/O Connector Cable with External Power Wires, Part Number 189985-01

## I/O Cable Adapters for Custom Cabling

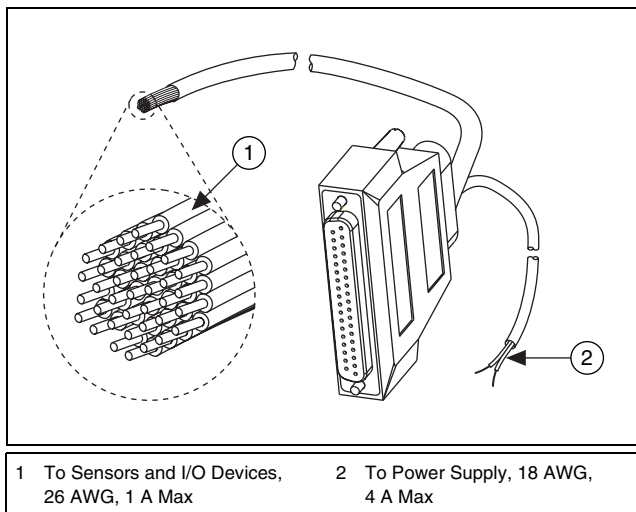
Part number 778620-04 is a 37-pin female to loose-wires cable adapter of 4 m length. You can terminate the loose wires directly to sensors or to custom connectors.



1 To Sensors and I/O Devices, 26 AWG, 1 A Max

**Figure 10.** 37-Pin I/O Connector Cable, Part Number 778620-04

Part number 189802-04 is a 37-pin female to loose-wires cable adapter of 4 m length, with external power wires. External power wires are useful if, for example, the power supply for the Compact FieldPoint system is in a sealed enclosure but the signal wiring must exit the enclosure.



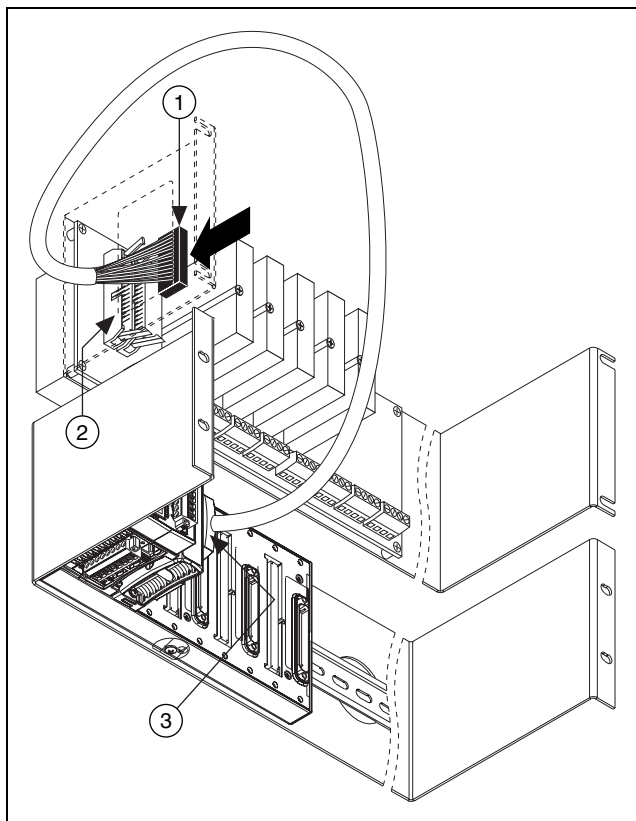
**Figure 11.** Compact FieldPoint 37-Pin I/O Connector Cable with External Power Wires, Part Number 189802-04

## Specialty I/O Cable Adapters

Part number 189935-01 is a 37-pin female to 5B08 backplane cable adapter of 1 m length. This cable adapter is designed to connect specific signals on the cFP-AI-100, cFP-AI-110, or cFP-AO-210 to an NI 5B08 backplane.

Connecting to a 5B08 backplane is useful if you need isolation between channels or if you have several different types of I/O signals.

NI offers several 5B accessories in addition to the 5B08 backplane, including power supplies and mounting accessories. Refer to the *Signal Conditioning* section of the NI catalog for information about NI 5B products.



- |                                 |                                     |
|---------------------------------|-------------------------------------|
| 1 5B Connector on Cable Adapter | 3 37-Pin Connector on Cable Adapter |
| 2 Socket on NI 5B08 Backplane   |                                     |

**Figure 12.** Compact FieldPoint 37-Pin to 5B08 Cable Adapter, Part Number 189935-01

**Table 4.** 37-Pin Cable to 5B08 Adapter Wire Identification

<b>37-Pin</b>	<b>AI Channel</b>	<b>AO Channel</b>	<b>5B Pin</b>
1	Ch 0 $V_{IN}$	Ch 0 $V_{OUT}$	1
3	Ch 1 $V_{IN}$	Ch 1 $V_{OUT}$	5
5	Ch 2 $V_{IN}$	Ch 2 $V_{OUT}$	7
7	Ch 3 $V_{IN}$	Ch 3 $V_{OUT}$	11
9	Ch 4 $V_{IN}$	Ch 4 $V_{OUT}$	13
11	Ch 5 $V_{IN}$	Ch 5 $V_{OUT}$	17
13	Ch 6 $V_{IN}$	Ch 6 $V_{OUT}$	19
15	Ch 7 $V_{IN}$	Ch 7 $V_{OUT}$	23
18	COM	COM	3
20	COM	COM	6
22	COM	COM	9
24	COM	COM	12
26	COM	COM	15
28	COM	COM	18
30	COM	COM	21
32	COM	COM	24

# Mounting Accessories

NI offers several accessories for mounting the Compact FieldPoint system on a DIN rail, in a standard 19 in. instrumentation rack, or on a panel.

Refer to the *cFP-20xx and cFP-BP-x User Manual* for instructions on using Compact FieldPoint mounting accessories. Follow the cooling guidelines in the *cFP-20xx and cFP-BP-x User Manual* when using any of the mounting options.

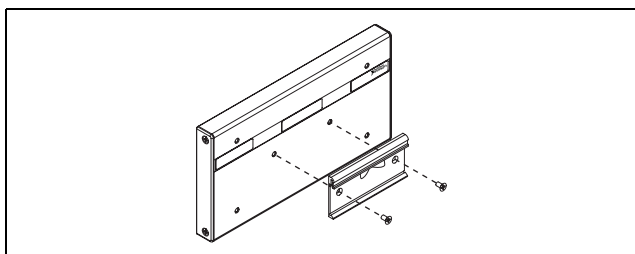
**Table 5.** Compact FieldPoint Mounting Accessories

Description	Product Name	Part Number
cFP DIN Rail Clip <sup>1</sup>	cFP DIN Rail Clip	778614-01
cFP Horizontal Panel-Mount Kit <sup>2</sup>	cFP-PM-H	778616-01
cFP Vertical Panel-Mount Kit	cFP-PM-V	778688-01
cFP Rack-Mount Kit	cFP-RM-8	778615-01

<sup>1</sup> NI recommends the cFP DIN Rail Clip for mounting only the cFP-BP-4. Use panel or rack mounting for the cFP-BP-8.

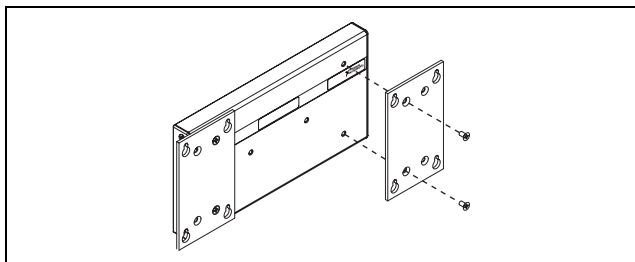
<sup>2</sup> All cFP backplanes are shipped with the horizontal panel-mount kit.

The cFP DIN rail clip kit is designed for quick, convenient mounting on a 35 mm DIN rail. The kit includes the two screws shown in Figure 13.

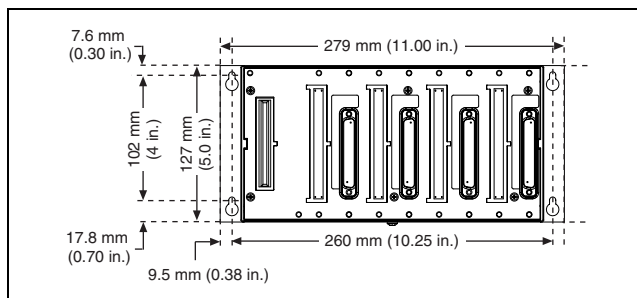


**Figure 13.** Compact FieldPoint DIN Rail Clip with cFP-BP-4

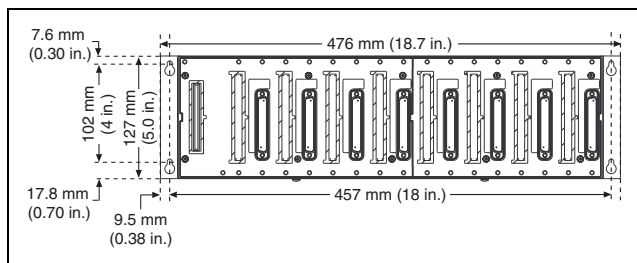
NI offers two kits for secure, permanent mounting on a panel. Each kit includes four screws for mounting the brackets to the backplane, as shown in Figures 14 and 17.



**Figure 14.** Installing Horizontal Panel-Mount Kit on cFP-BP-4

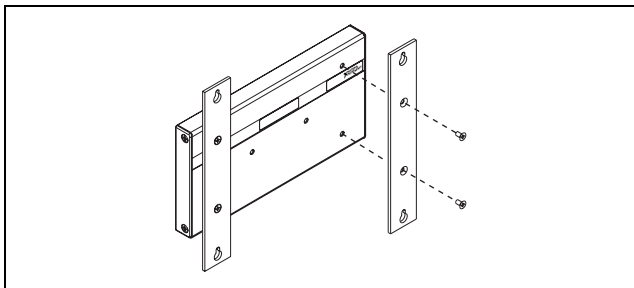


**Figure 15.** Horizontal Panel-Mount Kit Installed on cFP-BP-4

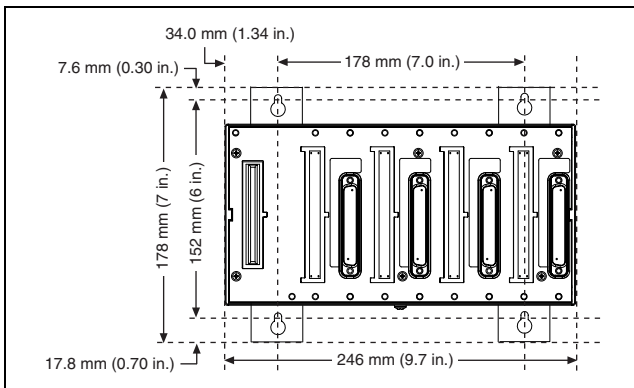


**Figure 16.** Horizontal Panel-Mount Kit Installed on cFP-BP-8

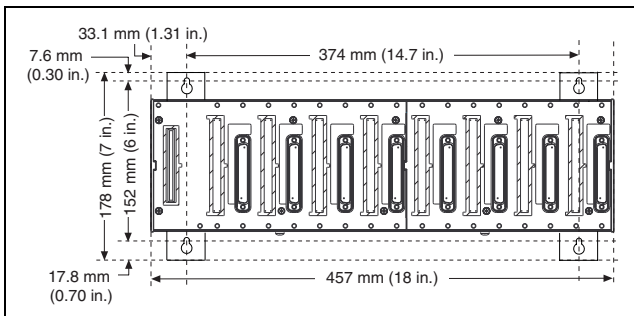




**Figure 17.** Installing Vertical Panel-Mount Kit on cFP-BP-4

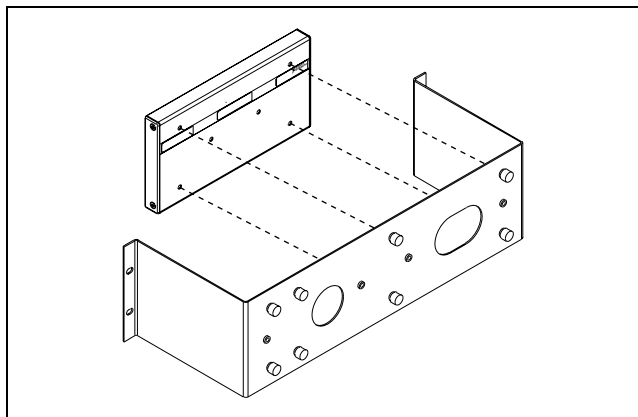


**Figure 18.** Vertical Panel-Mount Kit Installed on cFP-BP-4



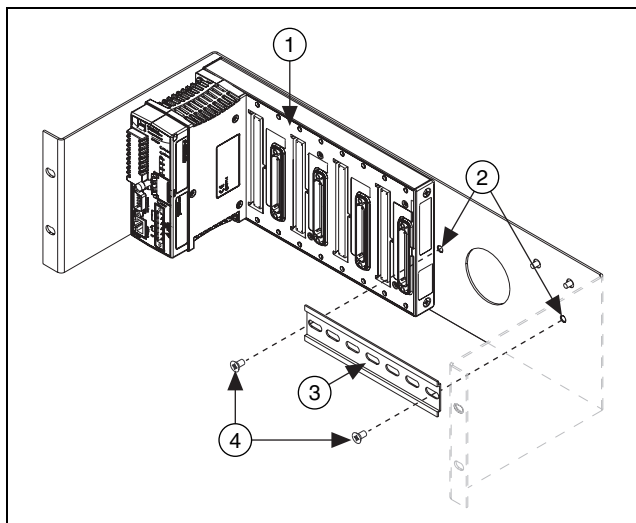
**Figure 19.** Vertical Panel-Mount Kit Installed on cFP-BP-8

NI offers the cFP Rack-Mount Kit for secure, permanent mounting on a 19 in. industrial rack. Use the captive screws to mount a cFP-BP-4 or cFP-BP-8 on the kit as shown in Figures 20 and 22.



**Figure 20.** Compact FieldPoint Rack-Mount Kit with cFP-BP-4

You can install an 8 in. DIN rail on the rack-mount kit to mount a power supply such as the PS-5. The captive #10-32 nuts on the rack-mount kit make it easy to attach a DIN rail. Use two #10-32 screws of 3/8 in. length as shown in Figure 21. If you want to install flat washers under the screw heads, use a slightly longer screw, up to 1/2 in. length. If you need more DIN rail space, you can install an 18 in. rail on a second rack-mount kit using four #10-32 screws.



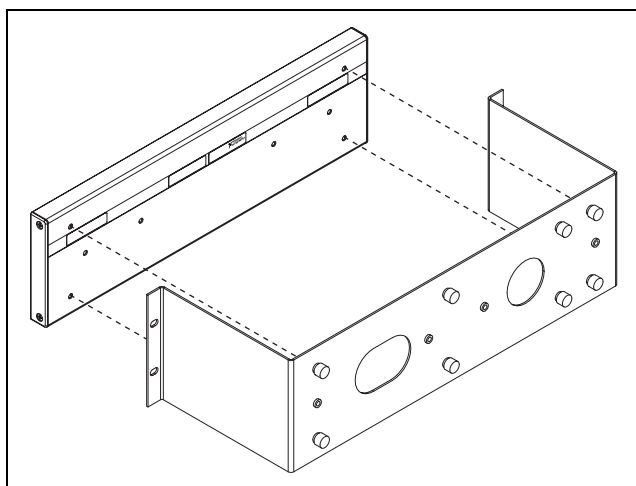
1 cFP-BP-4 Backplane

2 Captive #10-32 Nuts

3 8 in. DIN Rail

4 #10-32 Screws, 3/8-1/2 in.

**Figure 21.** Compact FieldPoint Rack-Mount Kit with cFP-BP-4

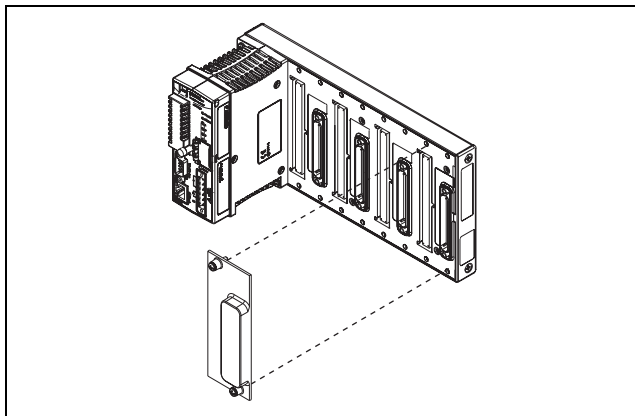


**Figure 22.** Compact FieldPoint Rack-Mount Kit with cFP-BP-8

# I/O Connector Protective Cover

NI offers a cover to protect unused slots on the backplane from damage caused by dirt, tools, and other potential hazards. The Compact FieldPoint protective cover is part number 778625-01.

Tighten the screws on the dust cover to 0.56 N · m (5 lb · in.) of torque. The nylon coating on the screws prevents them from loosening.



**Figure 23.** Compact FieldPoint Protective Cover

# Data Storage Accessories

---

NI offers four industrially rated Compact Flash cards for use as removable data storage devices with Compact FieldPoint controllers. These Compact Flash cards are designed for reliable performance from  $-40$  to  $85$  °C, which includes the operating temperature range of the Compact FieldPoint system.

**Table 6.** Compact Flash Accessories

Description	Part Number
64 MB Compact Flash	778622-64
128 MB Compact Flash	778622-128
256 MB Compact Flash	778622-256
512 MB Compact Flash	778622-512

Refer to the *cFP-20xx and cFP-BP-x User Manual* for instructions on using removable Compact Flash for data storage with the cFP-2020.

## Where to Go for Support

---

For more information about setting up the FieldPoint system, refer to these National Instruments documents:

- FieldPoint network module user manual
- Other FieldPoint I/O module operating instructions
- FieldPoint terminal base and connector block operating instructions

Go to [ni.com/support](http://ni.com/support) for the most current manuals, examples, and troubleshooting information.

For telephone support in the United States, create your service request at [ni.com/ask](http://ni.com/ask) and follow the calling instructions or dial 512 795 8248. For telephone support outside the United States, contact your local branch office:

Australia 1800 300 800, Austria 43 0 662 45 79 90 0,  
Belgium 32 0 2 757 00 20, Brazil 55 11 3262 3599,  
Canada (Calgary) 403 274 9391,  
Canada (Montreal) 514 288 5722,  
Canada (Ottawa) 613 233 5949, Canada (Québec) 514 694 8521,  
Canada (Toronto) 905 785 0085,

Canada (Vancouver) 514 685 7530, China 86 21 6555 7838,  
Czech Republic 420 2 2423 5774, Denmark 45 45 76 26 00,  
Finland 385 0 9 725 725 11, France 33 0 1 48 14 24 24,  
Germany 49 0 89 741 31 30, Greece 30 2 10 42 96 427,  
India 91 80 51190000, Israel 972 0 3 6393737,  
Italy 39 02 413091, Japan 81 3 5472 2970,  
Korea 82 02 3451 3400, Malaysia 603 9131 0918,  
Mexico 001 800 010 0793, Netherlands 31 0 348 433 466,  
New Zealand 0800 553 322, Norway 47 0 66 90 76 60,  
Poland 48 0 22 3390 150, Portugal 351 210 311 210,  
Russia 7 095 783 68 51, Singapore 65 6226 5886,  
Slovenia 386 3 425 4200, South Africa 27 0 11 805 8197,  
Spain 34 91 640 0085, Sweden 46 0 8 587 895 00,  
Switzerland 41 56 200 51 51, Taiwan 886 2 2528 7227,  
Thailand 662 992 7519, United Kingdom 44 0 1635 523545

FieldPoint™, National Instruments™, NI™, and ni.com™ are trademarks of National Instruments Corporation. Product and company names mentioned herein are trademarks or trade names of their respective companies. For patents covering National Instruments products, refer to the appropriate location: **Help»Patents** in your software, the `patents.txt` file on your CD, or `ni.com/patents`.

© 2002–2003 National Instruments Corp. All rights reserved.



323493B-01

Oct03