

COMPREHENSIVE SERVICES

We offer competitive repair and calibration services, as well as easily accessible documentation and free downloadable resources.

SELL YOUR SURPLUS

We buy new, used, decommissioned, and surplus parts from every NI series. We work out the best solution to suit your individual needs.

 Sell For Cash  Get Credit  Receive a Trade-In Deal

OBSOLETE NI HARDWARE IN STOCK & READY TO SHIP

We stock **New**, **New Surplus**, **Refurbished**, and **Reconditioned** NI Hardware.



Bridging the gap between the manufacturer and your legacy test system.

 1-800-915-6216

 www.apexwaves.com

 sales@apexwaves.com

All trademarks, brands, and brand names are the property of their respective owners.

Request a Quote

 **CLICK HERE**

cFP-AI-112

FieldPoint™ Operating Instructions

FP-AI-112 and cFP-AI-112

16-Channel, 16-Bit Analog Input Modules

These operating instructions describe how to install and use the FP-AI-112 and cFP-AI-112 analog input modules (referred to inclusively as the [c]FP-AI-112). For information about configuring and accessing the [c]FP-AI-112 over a network, refer to the user manual for the FieldPoint network module you are using.

Features

The [c]FP-AI-112 is a FieldPoint analog input module with the following features:

- 16 analog voltage input channels
- Eight voltage input ranges: 0–1 V, 0–5 V, 0–10 V, ± 60 mV, ± 300 mV, ± 1 V, ± 5 V, and ± 10 V
- 16-bit resolution
- 50 and 60 Hz filter settings
- 250 V_{rms} CAT II continuous channel-to-ground isolation, verified by 2,300 V_{rms}, 1 minute dielectric withstand test
- –40 to 70 °C operation
- Hot swappable

Installing the FP-AI-112

The FP-AI-112 mounts on a FieldPoint terminal base (FP-TB-*x*), which provides operating power to the module. Installing the FP-AI-112 onto a powered terminal base does not disrupt the operation of the FieldPoint bank.

To install the FP-AI-112, refer to Figure 1 and complete the following steps:

1. Slide the terminal base key to either position X (used for any module) or position 1 (used for the FP-AI-112).
2. Align the FP-AI-112 alignment slots with the guide rails on the terminal base.
3. Press firmly to seat the FP-AI-112 on the terminal base. When the FP-AI-112 is firmly seated, the latch on the terminal base locks it into place.

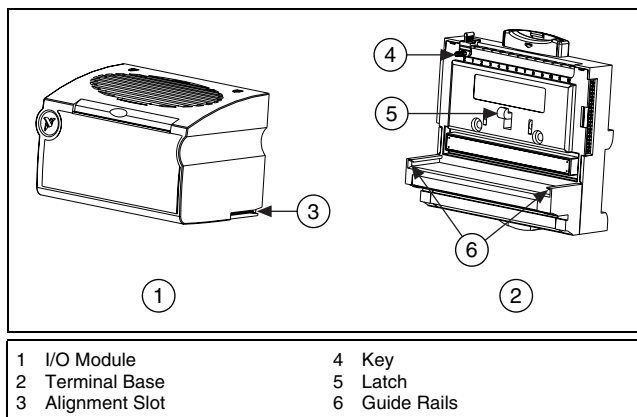

Figure 1. Installing the FP-AI-112

Installing the cFP-AI-112

The cFP-AI-112 mounts on a Compact FieldPoint backplane (cFP-BP-*x*), which provides operating power to the module. Installing the cFP-AI-112 onto a powered backplane does not disrupt the operation of the FieldPoint bank.

To install the cFP-AI-112, refer to Figure 2 and complete the following steps:

1. Align the captive screws on the cFP-AI-112 with the holes on the backplane. The alignment keys on the cFP-AI-112 prevent backward insertion.
2. Press firmly to seat the cFP-AI-112 on the backplane.

- Using a number 2 Phillips screwdriver with a shank of at least 64 mm (2.5 in.) length, tighten the captive screws to 1.1 N · m (10 lb · in.) of torque. The nylon coating on the screws prevents them from loosening.

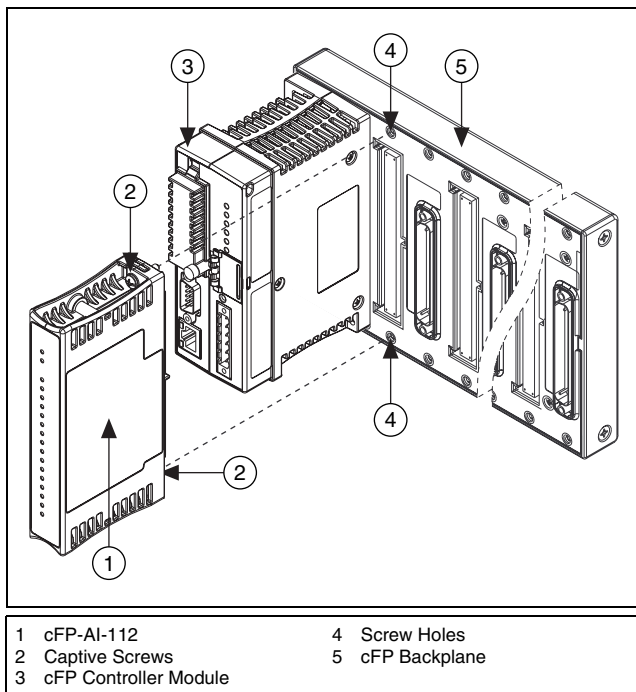

Figure 2. Installing the cFP-AI-112

Wiring the [c]FP-AI-112

The FP-TB-*x* terminal base has connections for each of the 16 input channels and for an optional external power supply to power field devices. The cFP-CB-*x* connector block provides the same connections. Each channel has one input terminal (V_{IN}) for voltage input. All 16 inputs are referenced to the COM terminals, which are internally connected to each other and to the C terminals. The channels share eight V_{SUP} terminals, all of which are internally connected to each other and to the V terminals.

You can use an external power supply to power field devices. Connect the positive lead of the external power supply to both V terminals and the negative lead to both C terminals. Ensure that the current through both V terminals can never exceed 2 A.

Install 2 A maximum, fast-acting fuses between the external power supply and the V terminals. The wiring diagrams in this document show fuses where appropriate.

Table 1 lists the terminal assignments for the signals associated with each channel. The terminal assignments are the same for the FP-TB-*x* terminal bases and the cFP-CB-*x* connector blocks.

Table 1. Terminal Assignments

Channel	Terminal Numbers		
	V _{IN}	V _{SUP}	COM
0	1	17	18
1	2	17	18
2	3	19	20
3	4	19	20
4	5	21	22
5	6	21	22
6	7	23	24
7	8	23	24
8	9	25	26
9	10	25	26
10	11	27	28
11	12	27	28
12	13	29	30
13	14	29	30
14	15	31	32
15	16	31	32



Caution Cascading power between two modules defeats isolation between those modules. Cascading power from the network module defeats all isolation between modules in the FieldPoint bank.

Measuring Voltage with the [c]FP-AI-112

Figure 3 shows how to connect a voltage source without an external power supply to one channel of the [c]FP-AI-112.

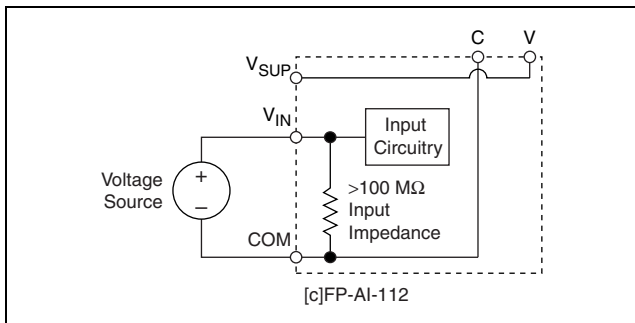

Figure 3. Voltage Source without External Power Supply

Figure 4 shows how to connect a voltage source with an external power supply to one channel of the [c]FP-AI-112.

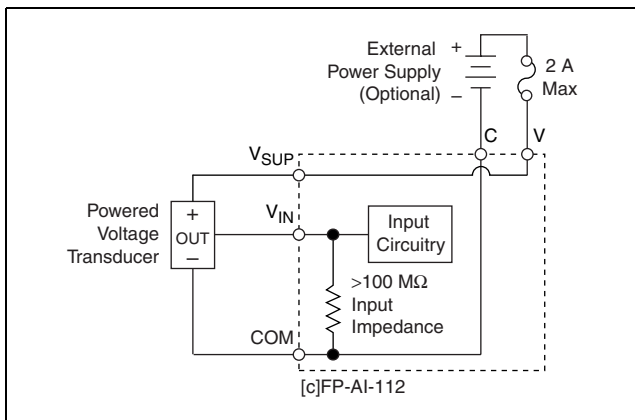

Figure 4. Voltage Source with External Power Supply

Input Ranges

The input ranges for voltage signals are 0–1 V, 0–5 V, 0–10 V, ±60 mV, ±300 mV, ±1 V, ±5 V, and ±10 V. To prevent inaccurate readings, choose an input range such that the signal you are measuring does not exceed either end of the range. Signals that greatly exceed the configured range can adversely affect measurements on other channels.

Measurements on a channel may be invalid for up to one update period after you change the input range.

Overranging

The [c]FP-AI-112 has an overranging feature that measures a little beyond the nominal values of each range. For example, the actual measurement limit of the ±10 V range is ±10.4 V. The overranging feature enables the [c]FP-AI-112 to compensate for field devices with span errors of up to +4% of full scale. Also, the overranging feature helps prevent errors caused by clipping.

Filter Settings

Three filter settings are available for each channel. The filters on the [c]FP-AI-112 input channels are comb filters that provide notches of rejection at multiples, or harmonics, of a fundamental frequency. You can select a fundamental frequency of 50, 60, or 500 Hz. At the 50 and 60 Hz settings, the [c]FP-AI-112 applies 95 dB of rejection at the fundamental frequency and at least 60 dB of rejection at each of the harmonics. In many cases, most of the noise components of input signals are related to the local AC power line frequency, so a filter setting of either 50 or 60 Hz is best.

The 500 Hz filter setting provides faster update rates but much less accurate measurements.

Update Rate

The update rate of the [c]FP-AI-112 is determined by the filter settings and the number of input ranges in use. Higher filter settings and fewer input ranges yield faster update rates. Use the following formula to determine the approximate update period:¹

$$\begin{aligned} & (\text{number of channels with 50 Hz filter}) \times 0.061 \text{ s} + \\ & (\text{number of input ranges with 50 Hz filter}) \times 0.12 \text{ s} + \\ & (\text{number of channels with 60 Hz filter}) \times 0.051 \text{ s} + \end{aligned}$$

¹ The update rate is the reciprocal of the update period.

$$\begin{aligned} & (\text{number of input ranges with 60 Hz filter}) \times 0.10 \text{ s} + \\ & (\text{number of channels with 500 Hz filter}) \times 0.007 \text{ s} + \\ & (\text{number of input ranges with 500 Hz filter}) \times 0.012 \text{ s} + 0.16 \text{ s} \\ & = \text{Update Period} \end{aligned}$$

For the fastest performance, configure all unused channels for the 500 Hz filter setting and for an input range in use on one or more other channels with the 500 Hz filter setting. For example, if 10 channels are configured for 0–10 V input and 500 Hz, four channels are configured for 0–5 V and 60 Hz, and two channels are unconnected, use the FieldPoint software to configure the unconnected channels for 0–10 V input and 500 Hz filter setting.

Some combinations of two input ranges count as only one range for calculating update rates. Those combinations are ± 60 mV and ± 300 mV; 0–1 V and 0–5 V; and ± 1 V and ± 5 V.

The update rate does not affect the rate at which the network module reads the data. Set up your application so that the update rate is faster than the rate at which the network module polls the [c]FP-AI-112 for data.

Status Indicators

The [c]FP-AI-112 has two green status LEDs, **POWER** and **READY**. After you insert the [c]FP-AI-112 into a terminal base or backplane and apply power to the connected network module, the green **POWER** indicator lights and the [c]FP-AI-112 informs the network module of its presence. When the network module recognizes the [c]FP-AI-112, it sends initial configuration information to the [c]FP-AI-112. After the [c]FP-AI-112 receives this initial information, the green **READY** indicator lights and the module is in normal operating mode.

Upgrading the FieldPoint Firmware

You may need to upgrade the FieldPoint firmware when you add new I/O modules to the FieldPoint system. For information on determining which firmware you need and how to upgrade your firmware, go to ni.com/info and enter `fpmatrix`.

Isolation and Safety Guidelines



Caution Read the following information before attempting to connect the [c]FP-AI-112 to any circuits that may contain hazardous voltages.

This section describes the isolation of the [c]FP-AI-112 and its compliance with international safety standards. The field wiring connections are isolated from the backplane and the inter-module communication bus. The isolation barriers in the module provide 250 V_{rms} Installation Category II continuous isolation, verified by 2,300 V_{rms}, 1 minute dielectric withstand test. The [c]FP-AI-112 provides *double insulation* (compliant with IEC 61010-1) for working voltages of 250 V_{rms}¹. Safety standards (such as those published by UL and IEC) require the use of double insulation between hazardous voltages and any human-accessible parts or circuits.

Never try to use any isolation product between human-accessible parts (such as DIN rails or monitoring stations) and circuits that can be at hazardous potentials under normal conditions, unless the product is specifically designed for such an application, as is the [c]FP-AI-112.

Even though the [c]FP-AI-112 is designed to handle applications with hazardous potentials, follow these guidelines to ensure a safe total system:

- There is no isolation between channels on the [c]FP-AI-112. If a hazardous voltage is present on any channel, all channels are considered hazardous. Make sure that all other devices and circuits connected to the module are properly insulated from human contact.
- Do *not* share the external supply voltages (the V and C terminals) with other devices (including other FieldPoint devices), unless those devices are isolated from human contact.
- For Compact FieldPoint, you *must* connect the protective earth (PE) ground terminal on the cFP-BP-*x* backplane to the system safety ground. The backplane PE ground terminal has the following symbol stamped beside it: \oplus . Connect the backplane PE ground terminal to the system safety ground

¹ Working voltage is defined as the signal voltage plus the common-mode voltage. Common-mode voltage is the voltage of the module with respect to ground.

using 14 AWG (1.6 mm) wire with a ring lug. Use the 5/16 in. panhead screw shipped with the backplane to secure the ring lug to the backplane PE ground terminal.

- As with any hazardous voltage wiring, make sure that all wiring and connections meet applicable electrical codes and commonsense practices. Mount terminal bases and backplanes in an area, position, or cabinet that prevents accidental or unauthorized access to wiring that carries hazardous voltages.
- Do *not* use the [c]FP-AI-112 as the only isolating barrier between human contact and working voltages higher than $250 V_{\text{rms}}$.
- Operate the [c]FP-AI-112 only at or below Pollution Degree 2. Pollution Degree 2 means that only nonconductive pollution occurs in most cases. Occasionally, however, a temporary conductivity caused by condensation must be expected.
- Do *not* operate FieldPoint products in an explosive atmosphere or where there may be flammable gases or fumes. If you need to operate FieldPoint products in such an environment, the FieldPoint products *must* be in a suitably rated enclosure.
- Operate the [c]FP-AI-112 at or below Installation Category II. Installation Category II is for measurements performed on circuits directly connected to the low-voltage installation. This category refers to local-level distribution, such as that provided by a standard wall outlet.

Specifications

The following specifications are typical for the -40 to 70 °C temperature range and for 50 and 60 Hz filter settings unless otherwise noted. Specifications are subject to change without notice.

Input Characteristics

Number of channels	16
ADC resolution	16 bits at 50 or 60 Hz; 10 bits at 500 Hz (refer to table)
Type of ADC.....	Delta-sigma

Effective resolution by input range and filter setting

Nominal Input Range	With Overranging	Effective Resolution* at 50 or 60 Hz	Effective Resolution* at 500 Hz
±60 mV	±65 mV	3 µV	25 µV
±300 mV	±325 mV	16 µV	100 µV
±1 V	±1.04 V	40 µV	300 µV
±5 V	±5.2 V	190 µV	1500 µV
±10 V	±10.4 V	380 µV	3000 µV
0–1 V	0–1.04 V	20 µV	300 µV
0–5 V	0–5.2 V	95 µV	1500 µV
0–10 V	0–10.4 V	190 µV	3000 µV

*Includes quantization errors and typical rms noise.

Update period and input bandwidth by filter setting

Characteristic	Filter Settings		
	50 Hz	60 Hz	500 Hz
Update period*	1.25–1.75 s	1.05–1.45 s	0.27–0.32 s
Input bandwidth (–3 dB)	13 Hz	16 Hz	130 Hz

* Applies when all 16 channels are set to the same filter setting. Refer to the [Update Rate](#) section for information about calculating the update rate.

Normal-mode rejection 95 dB

Nonlinearity 0.0015% (monotonicity¹ warranted over the operating temperature range)

Input impedance (with power on) >100 MΩ

Overvoltage protection ±40 V

Input current

25 °C 400 pA typ, 1 nA max

70 °C 3 nA typ, 15 nA max

¹ A characteristic of an ADC in which the digital code output always increases as the value of the analog input to it increases.

Typical and warranted accuracy by input range and temperature range

Nominal Input Range	Typical Accuracy at 15 to 35 °C (% of Reading; % of Full Scale)	Warranted Accuracy at 15 to 35 °C (% of Reading; % of Full Scale)
±60 mV	±0.03%; ±0.05%	±0.05%; ±0.3%
±300 mV	±0.03%; ±0.015%	±0.05%; ±0.1%
±1 V	±0.03%; ±0.008%	±0.05%; ±0.04%
±5 V	±0.03%; ±0.005%	±0.05%; ±0.02%
±10 V	±0.03%; ±0.005%	±0.05%; ±0.02%
0–1 V	±0.03%; ±0.005%	±0.05%; ±0.03%
0–5 V	±0.03%; ±0.003%	±0.05%; ±0.01%
0–10 V	±0.03%; ±0.003%	±0.05%; ±0.01%

Nominal Input Range	Typical Accuracy at –40 to 70 °C (% of Reading; % of Full Scale)	Warranted Accuracy at –40 to 70 °C (% of Reading; % of Full Scale)
±60 mV	±0.06%; ±0.35%	±0.10%; ±1.50%
±300 mV	±0.06%; ±0.08%	±0.10%; ±0.40%
±1 V	±0.06%; ±0.03%	±0.10%; ±0.13%
±5 V	±0.06%; ±0.01%	±0.10%; ±0.04%
±10 V	±0.06%; ±0.01%	±0.10%; ±0.03%
0–1 V	±0.06%; ±0.025%	±0.10%; ±0.12%
0–5 V	±0.06%; ±0.007%	±0.10%; ±0.03%
0–10 V	±0.06%; ±0.005%	±0.10%; ±0.02%



Note Full scale is the maximum value of the nominal input range. For example, for the ±10 V input range, full scale is 10 V and ±0.01% of full scale is 1 mV.

Gain error drift..... ±20 ppm/°C

Offset error drift..... 6 µV/°C

Physical Characteristics

Indicators Green **POWER** and **READY** indicators

Weight

FP-AI-112..... 142 g (5.0 oz)

cFP-AI-112..... 113 g (4.0 oz)

Power Requirements

Power from network module 350 mW

Isolation Voltage

Channel-to-ground isolation

Continuous 250 V_{rms},
Installation Category II

Dielectric withstand..... 2,300 V_{rms}, 1 minute

Channel-to-channel isolation None

Environmental

FieldPoint modules are intended for indoor use only. For outdoor use, they must be mounted inside a sealed enclosure.

Operating temperature -40 to 70 °C

Storage temperature -50 to 85 °C

Humidity 10 to 90% RH,
noncondensing

Maximum altitude..... 2,000 m; at higher altitudes
the isolation voltage ratings
must be lowered.

Pollution Degree 2

Shock and Vibration

These specifications apply only to the cFP-AI-112. NI recommends Compact FieldPoint if your application is subject to shock and vibration.

Operating vibration, random (IEC 60068-2-64).....	10–500 Hz, 5 g _{rms}
Operating vibration, sinusoidal (IEC 60068-2-6).....	10–500 Hz, 5 g
Operating shock (IEC 60068-2-27).....	50 g, 3 ms half sine, 18 shocks at 6 orientations; 30 g, 11 ms half sine, 18 shocks at 6 orientations

Safety

This product is designed to meet the requirements of the following standards of safety for electrical equipment for measurement, control, and laboratory use:

- IEC 61010-1, EN 61010-1
- UL 61010-1
- CAN/CSA-C22.2 No. 61010-1



Note For UL, hazardous locations, and other safety certifications, refer to the product label, or visit ni.com/certification, search by model number or product line, and click the appropriate link in the Certification column.

Electromagnetic Compatibility

Emissions.....	EN 55011 Class A at 10 m; FCC Part 15A above 1 GHz
Immunity.....	EN 61326:1997 + A2:2001, Table 1

CE, C-Tick, and FCC Part 15 (Class A) Compliant



Note For EMC compliance, operate this device with shielded cabling.

CE Compliance

This product meets the essential requirements of applicable European Directives, as amended for CE marking, as follows:

Low-Voltage Directive (safety)..... 73/23/EEC

Electromagnetic Compatibility

Directive (EMC) 89/336/EEC



Note Refer to the Declaration of Conformity (DoC) for this product for any additional regulatory compliance information. To obtain the DoC for this product, visit ni.com/certification, search by model number or product line, and click the appropriate link in the Certification column.

Mechanical Dimensions

Figure 5 shows the mechanical dimensions of the FP-AI-112 installed on a terminal base. If you are using the cFP-AI-112, refer to the Compact FieldPoint controller user manual for the dimensions and cabling clearance requirements of the Compact FieldPoint system.

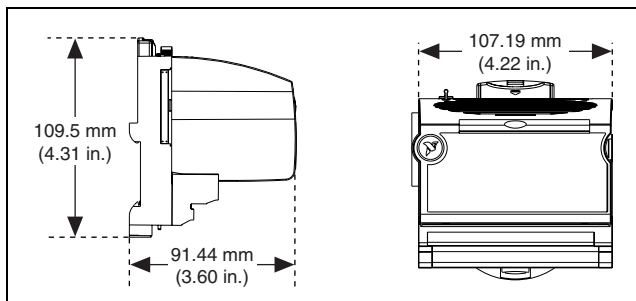

Figure 5. FP-AI-112 Mechanical Dimensions

Where to Go for Support

For more information about setting up the FieldPoint system, refer to these National Instruments documents:

- FieldPoint network module user manual
- Other FieldPoint I/O module operating instructions
- FieldPoint terminal base and connector block operating instructions

Go to ni.com/support for the most current manuals, examples, and troubleshooting information.

National Instruments corporate headquarters is located at 11500 North Mopac Expressway, Austin, Texas, 78759-3504. National Instruments also has offices located around the world to help address your support needs. For telephone support in the United States, create your service request at ni.com/support and follow the calling instructions or dial 512 795 8248. For telephone support outside the United States, contact your local branch office:

Australia 1800 300 800, Austria 43 0 662 45 79 90 0,
Belgium 32 0 2 757 00 20, Brazil 55 11 3262 3599,
Canada (Calgary) 403 274 9391, Canada (Ottawa) 613 233 5949,
Canada (Québec) 450 510 3055, Canada (Toronto) 905 785 0085,
Canada (Vancouver) 604 685 7530, China 86 21 6555 7838,
Czech Republic 420 224 235 774, Denmark 45 45 76 26 00,
Finland 385 0 9 725 725 11, France 33 0 1 48 14 24 24,
Germany 49 0 89 741 31 30, India 91 80 51190000,
Israel 972 0 3 6393737, Italy 39 02 413091,
Japan 81 3 5472 2970, Korea 82 02 3451 3400,
Malaysia 603 9131 0918, Mexico 01 800 010 0793,
Netherlands 31 0 348 433 466, New Zealand 0800 553 322,
Norway 47 0 66 90 76 60, Poland 48 22 3390150,
Portugal 351 210 311 210, Russia 7 095 783 68 51,
Singapore 65 6226 5886, Slovenia 386 3 425 4200,
South Africa 27 0 11 805 8197, Spain 34 91 640 0085,
Sweden 46 0 8 587 895 00, Switzerland 41 56 200 51 51,
Taiwan 886 2 2528 7227, Thailand 662 992 7519,
United Kingdom 44 0 1635 523545

FieldPoint™, National Instruments™, NI™, and ni.com™ are trademarks of National Instruments Corporation. Product and company names mentioned herein are trademarks or trade names of their respective companies. For patents covering National Instruments products, refer to the appropriate location: **Help»Patents** in your software, the `patents.txt` file on your CD, or `ni.com/patents`.

© 2004 National Instruments Corp. All rights reserved.



371330A-01

Jul04