

COMPREHENSIVE SERVICES

We offer competitive repair and calibration services, as well as easily accessible documentation and free downloadable resources.

SELL YOUR SURPLUS

We buy new, used, decommissioned, and surplus parts from every NI series. We work out the best solution to suit your individual needs.

 Sell For Cash  Get Credit  Receive a Trade-In Deal

OBSOLETE NI HARDWARE IN STOCK & READY TO SHIP

We stock **New**, **New Surplus**, **Refurbished**, and **Reconditioned** NI Hardware.



Bridging the gap between the manufacturer and your legacy test system.

 1-800-915-6216

 www.apexwaves.com

 sales@apexwaves.com

All trademarks, brands, and brand names are the property of their respective owners.

Request a Quote

 **CLICK HERE**

cFP-CB-1

FieldPoint™ Operating Instructions

cFP-TC-125

Eight-Channel Thermocouple Input Module

These operating instructions describe how to install and use the National Instruments cFP-TC-125 thermocouple input module. For information about configuring and accessing the cFP-TC-125 over a network, refer to the user manual for the FieldPoint network module you are using.

Features

The cFP-TC-125 is a Compact FieldPoint thermocouple input module with the following features:

- 250 V common-mode rejection
- Eight differential thermocouple or millivolt inputs
- Built-in linearization and cold-junction compensation for eight thermocouple types: J, K, R, S, T, N, E, and B
- –20 to 80 mV range for voltage input
- Open-thermocouple detection and indicator LEDs
- Up to 16-bit resolution
- 50/60 Hz filter configurable per channel
- 250 V_{rms} CAT II continuous channel-to-ground isolation, verified by 2,300 V_{rms}, 5 s dielectric withstand test
- –40 to 70 °C operation
- Hot swappable

Installing the cFP-TC-125

The cFP-TC-125 mounts on a Compact FieldPoint backplane (cFP-BP-*x* or cFP-180*x*), which provides operating power to the module. Installing the cFP-TC-125 onto a powered backplane does not disrupt the operation of the bank.

To install the cFP-TC-125, refer to Figure 1 and complete the following steps:

1. Align the captive screws on the cFP-TC-125 with the holes on the backplane. The alignment keys on the cFP-TC-125 prevent backward insertion.
2. Press firmly to seat the cFP-TC-125 on the backplane.
3. Using a number 2 Phillips screwdriver with a shank of at least 64 mm (2.5 in.) length, tighten the captive screws to $1.1 \text{ N} \cdot \text{m}$ (10 lb · in.) of torque. The nylon coating on the screws prevents them from loosening.

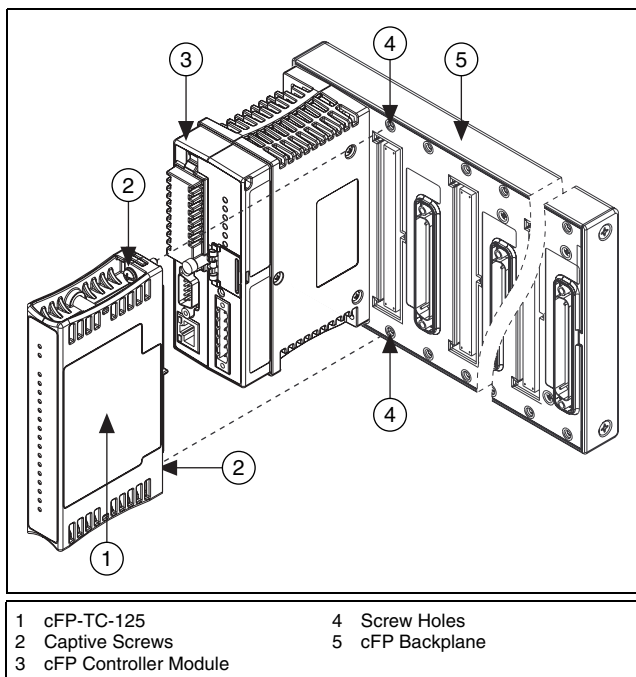

Figure 1. Installing the cFP-TC-125

Wiring the cFP-TC-125

The cFP-CB-*x* connector block has connections for each of the eight differential input channels on the cFP-TC-125. Table 1 lists the terminal assignments for the signals associated with each channel.

Table 1. Terminal Assignments

Channel	Terminal Numbers	
	IN(+)	IN(-)
0	1	2
1	3	4
2	5	6
3	7	8
4	9	10
5	11	12
6	13	14
7	15	16



Caution Do not connect anything to the V and C terminals on the connector block.



Caution Ensure that hazardous voltage wiring is performed only by qualified personnel adhering to local electrical standards. Hazardous voltage is voltage greater than $30 V_{\text{rms}}$ / 42.4 V peak or 60 VDC.

Taking Measurements with the cFP-TC-125

The cFP-TC-125 has eight differential input channels. Each channel is isolated from other modules in the FieldPoint system. There is no safety isolation between individual channels on the

cFP-TC-125. Each channel is filtered, then sampled by a 16-bit analog-to-digital converter (ADC). Figure 2 shows the input circuitry on one channel of the cFP-TC-125.

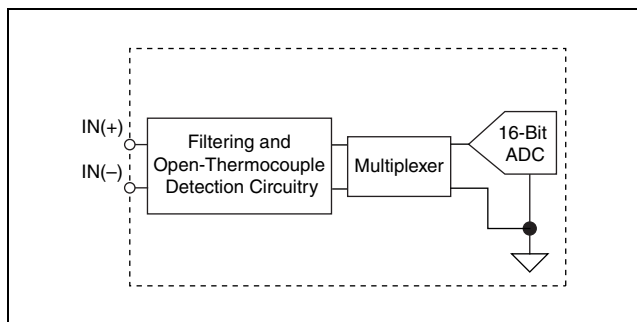

Figure 2. cFP-TC-125 Input Circuitry on One Channel

Common-Mode Rejection

Each channel of the cFP-TC-125 rejects up to ± 250 V common-mode voltage as referenced to earth ground.



Caution The difference in common-mode voltage between any two channels must not exceed 250 V.

Connecting Voltage Input Signals

Connect the positive lead of a millivolt signal to the IN(+) terminal and the negative lead to the IN(-) terminal. Figure 3 shows a millivolt source connected to one channel of the cFP-TC-125.

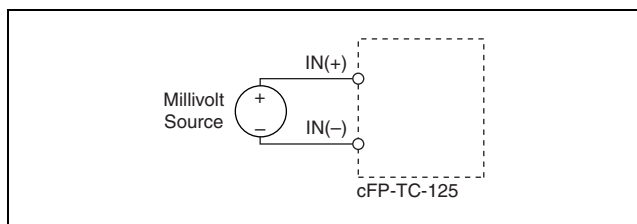

Figure 3. Connecting a Millivolt Source to the cFP-TC-125

The voltage input range is -20 to 80 mV. An input signal outside the range causes the cFP-TC-125 to report an **Out of range** error for the affected channel. If you select the -20 to 80 mV range for

an input channel in software, selecting a thermocouple type for that channel has no effect.

Connecting Thermocouple Input Signals

Connect the positive lead of a thermocouple to the IN(+) terminal and the negative lead to the IN(-) terminal. Thermocouple wires are color coded. The color code depends on the thermocouple type and the country of manufacture. If you are unsure which of the thermocouple leads is the positive and which is the negative, check the thermocouple documentation or the thermocouple wire spool. The cFP-TC-125 supports thermocouple types J, K, R, S, T, N, E, and B. Figure 4 shows a shielded thermocouple connected to one channel of the cFP-TC-125.

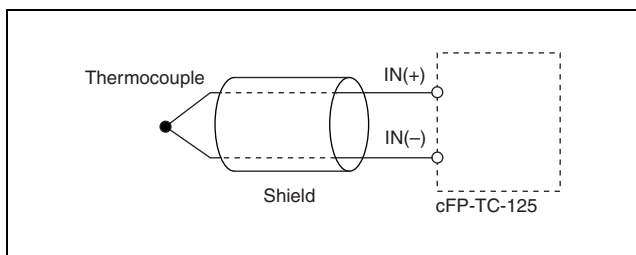

Figure 4. Connecting a Shielded Thermocouple to the cFP-TC-125

The cFP-TC-125 linearizes the thermocouple voltage and returns a reading in units of temperature. The available ranges are 0 to 2,048 K, -270 to 1,770 °C, and -454 to 3,218 °F. Temperatures outside these ranges cause the cFP-TC-125 to report an **Out of range** error for the affected channel and to turn on the LED for that channel.



Note You must configure each channel of the cFP-TC-125 for the type of thermocouple connected to it.

The algorithms in the cFP-TC-125 linearize measurements according to the National Institute of Standards and Technology NIST-175 standard for thermocouple characteristics, based on the ITS-90 International Temperature Scale. These linearization algorithms are typically accurate to within ± 0.05 °C (0.03 °F) of the NIST standard over the entire range of temperatures defined by the NIST for the supported thermocouple types.

All-Channel Update Period

Calculate the all-channel update period as follows:

$$24 \text{ ms}(\text{Number of Channels with 50/60 Hz Filter Disabled}) + 114 \text{ ms}(\text{Number of Channels with 50/60 Hz Filter Enabled}) + \text{CJ Constant} = \text{Update Period}$$

where *CJ Constant* equals 27 ms if the 50/60 Hz filter is disabled for the CJ Temperature channel, and 77 ms if the filter is enabled for that channel.

Detecting Open Thermocouples

The cFP-TC-125 detects open thermocouples on channels configured for temperature ranges. When the cFP-TC-125 detects an open thermocouple, it reports an **Open thermocouple** error for that channel and lights the corresponding red LED.

Typically the open-thermocouple LED lights within 1 s of an open-thermocouple occurrence.

Cold-Junction Compensation

Connecting thermocouple leads to the connector block creates new thermocouple junctions between the thermocouple wires and the terminals. These *cold junctions* affect the measured readings of the thermocouple. The cFP-TC-125 automatically enables cold-junction compensation when you select a temperature range but not when you select a voltage range. The cFP-TC-125 reads the temperature of the terminals from temperature-measuring elements built into the connector block. The module uses this temperature data to compensate for cold junctions and reports it as **CJ Temperature** in software. If the cFP-TC-125 senses a terminal temperature of less than $-50\text{ }^{\circ}\text{C}$ or more than $85\text{ }^{\circ}\text{C}$, the cFP-TC-125 reports **Out of range** for the cold-junction temperature and for all of the channel temperatures.



Note For optimal cold-junction compensation, NI recommends that you use the cFP-CB-3 isothermal connector block.

The default setting is for the cFP-TC-125 to enable cold-junction compensation for all temperature measurements. To disable this feature and use a software algorithm instead, set the **CJC Source** attribute of the CJ Temperature channel to either 0 or $25\text{ }^{\circ}\text{C}$. Selecting one of these settings causes the cFP-TC-125 to assume a cold-junction temperature of either 0 or $25\text{ }^{\circ}\text{C}$ for all temperature

readings. Regardless of the setting of the CJC Source attribute, CJ Temperature continues to reflect the actual measured temperature of the terminals. This method of software cold-junction compensation is sufficient for applications in which temperatures are fairly stable and uniform across the system.

Determining Measurement Accuracy and Minimizing Errors

It is difficult to define temperature measurement errors in simple terms because thermocouples are very nonlinear. The errors depend in part on the thermocouple type, the cold-junction temperature, the temperature being measured, and the accuracy of the thermocouple. Also, it is important to distinguish between *absolute accuracy* and *resolution*. Absolute accuracy (referred to in this document as *accuracy*) is a measure of how close a measurement of the cFP-TC-125 is to the correct value. Absolute accuracy includes all gain and offset errors, differential and integral nonlinearity, quantization errors, noise errors, errors in linearization algorithms, and errors in measurement of the cold-junction temperature. Resolution refers to the smallest measurable change in a value.



Caution Electromagnetic radiation can adversely affect the measurement accuracy of the cFP-TC-125. Refer to the [Electromagnetic Compatibility](#) section for information about the effects of electromagnetic radiation.

The following charts show the typical and maximum errors for the cFP-TC-125 with the 50/60 Hz filter enabled, operating at room temperature (15 to 35 °C) and over the full ambient temperature range (–40 to 70 °C). The values in the charts apply to measurements taken from thermocouples connected to the module using the cFP-CB-3, and they include a 0.2 °C temperature gradient across the terminals. The values do not include the accuracy of thermocouples.

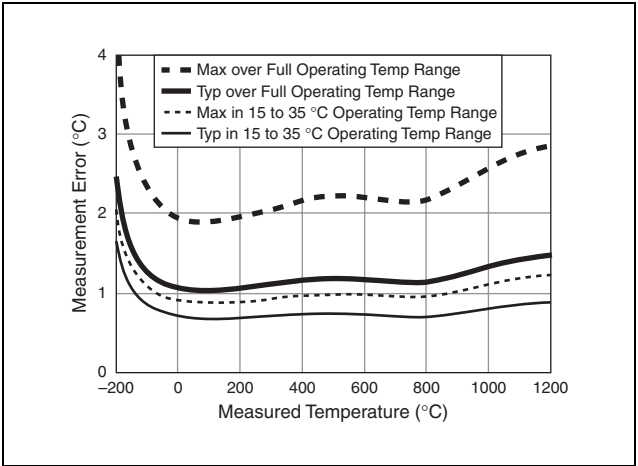

Figure 5. Type J Errors

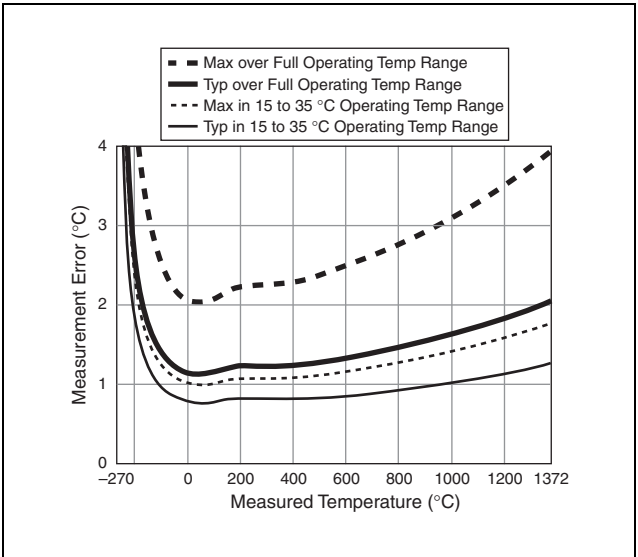

Figure 6. Type K Errors

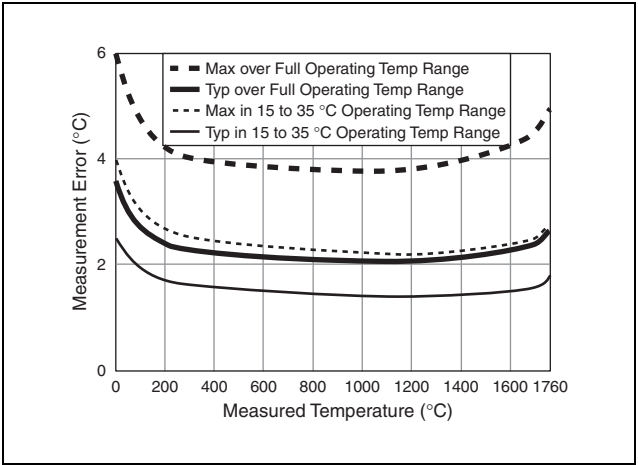

Figure 7. Types R and S Errors

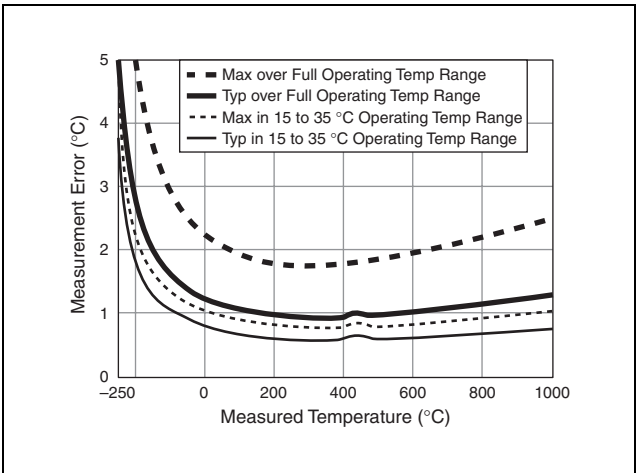

Figure 8. Types T and E Errors

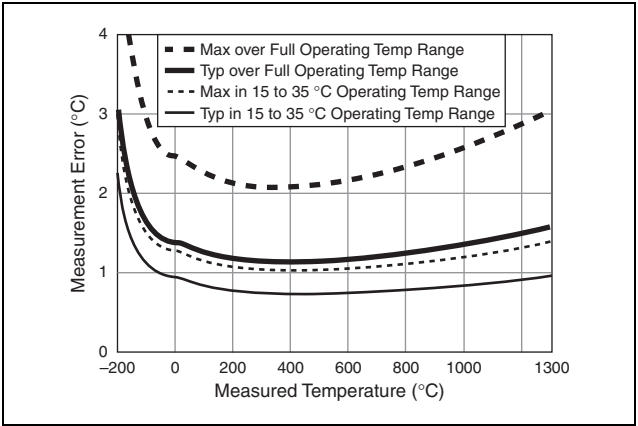

Figure 9. Type N Errors

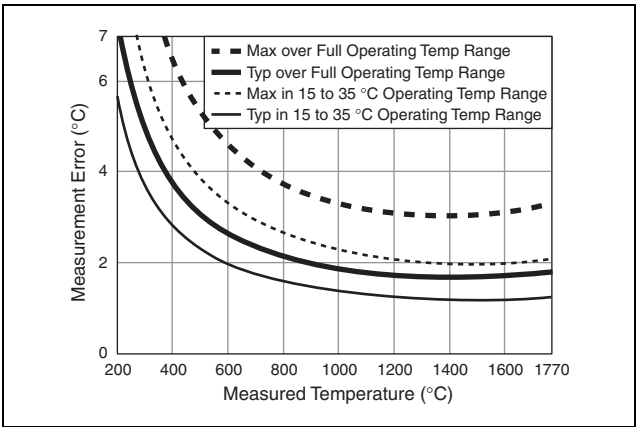

Figure 10. Type B Errors

Cold-Junction Temperature Measurement Accuracy

Heat dissipated by adjacent modules (or other nearby heat sources) can cause errors in thermocouple measurements by heating up the terminals so that they are at a different temperature than the sensor used to measure the cold junction. The thermal gradient generated across the terminals can cause the terminals of different channels

to be at different temperatures, so the resulting measurement creates errors not only in absolute accuracy but also in the relative accuracy between channels. The accuracy specifications for the cFP-TC-125 include the errors caused by a 0.2 °C (0.36 °F) gradient. The actual gradient you can expect to encounter depends on the connector block you use and the details of your installation. For more information about minimizing thermal gradients, refer to the *cFP-CB-1* and *cFP-CB-3 Compact FieldPoint Connector Blocks Operating Instructions*.

Status Indicators

The cFP-TC-125 has two green status LEDs, **POWER** and **READY**. After you install the cFP-TC-125 and apply power to the connected network module, the green **POWER** indicator lights and the cFP-TC-125 informs the network module of its presence. When the network module recognizes the cFP-TC-125, it sends initial configuration information to the cFP-TC-125. After the cFP-TC-125 receives this initial information, the green **READY** indicator lights and the module is in normal operating mode.

In addition to the green **POWER** and **READY** indicators, the cFP-TC-125 has eight red LEDs labeled **0** to **7**. When the module detects a signal outside a configured temperature range on a channel, the red LED for that channel lights. Signals outside the configured range include those that indicate open thermocouples. The red LEDs do not light in response to out-of-range signals on channels configured for the -20 to 80 mV range.

Upgrading the FieldPoint Firmware

You may need to upgrade the FieldPoint firmware when you add new I/O modules to the FieldPoint system. For information on determining which firmware you need and how to upgrade the firmware, go to ni.com/info and enter `fpmatrix`.

Isolation and Safety Guidelines



Caution Read the following information before attempting to connect the cFP-TC-125 to any circuits that may contain *hazardous voltages*.¹

¹ A hazardous voltage is a voltage greater than 42.4 V_{peak} or 60 VDC.

This section describes the isolation of the cFP-TC-125 and its compliance with international safety standards. The field wiring connections are isolated from the backplane and the inter-module communication bus. The isolation barriers in the module provide 250 V_{rms} Measurement Category II continuous channel-to-backplane and channel-to-ground isolation, verified by 2,300 V_{rms}, 5 s dielectric withstand test. The cFP-TC-125 provides *double insulation* (compliant with IEC 61010-1) for working voltages of 250 V_{rms}.¹ Safety standards (such as those published by UL and IEC) require the use of double insulation between hazardous voltages and any human-accessible parts or circuits.

Never try to use any isolation product between human-accessible parts (such as DIN rails or monitoring stations) and circuits that can be at hazardous potentials under normal conditions, unless the product is specifically designed for such an application, as is the cFP-TC-125.

Even though the cFP-TC-125 is designed to handle applications with hazardous potentials, follow these guidelines to ensure a safe system:

- Do *not* share the external supply voltages (the V and C terminals) with other devices (including other FieldPoint devices), unless those devices are isolated from human contact.
- You *must* connect the protective earth (PE) ground terminal on the cFP-BP-x backplane to the system safety ground. The backplane PE ground terminal has the following symbol stamped beside it: . Connect the backplane PE ground terminal to the system safety ground using 14 AWG (1.6 mm) wire with a ring lug. Use the 5/16 in. panhead screw shipped with the backplane to secure the ring lug to the backplane PE ground terminal.
- The cFP-TC-125 is a UL Recognized component. The entire Compact FieldPoint system must be installed in a UL Listed, suitably rated NEMA or IP enclosure for safe use.

¹ *Working voltage* is defined as the signal voltage plus the common-mode voltage. *Common-mode voltage* is the voltage of the module with respect to ground.

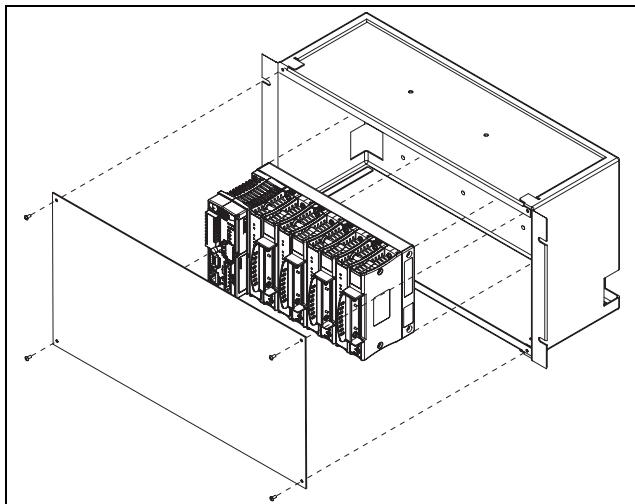

Figure 11. Installing the Compact FieldPoint System in an Enclosure

- As with any hazardous voltage wiring, make sure that all wiring and connections meet applicable electrical codes and commonsense practices. Mount backplanes in an area, position, or cabinet that prevents accidental or unauthorized access to wiring that carries hazardous voltages.
- Do *not* use the cFP-TC-125 as the only isolating barrier between human contact and working voltages higher than $250 V_{\text{rms}}$.
- Operate the cFP-TC-125 only at or below Pollution Degree 2. Pollution Degree 2 means that only nonconductive pollution occurs in most cases. Occasionally, however, condensation causes temporary conductivity.
- Operate the cFP-TC-125 at or below Measurement Category II. Measurement Category II is for measurements performed on circuits directly connected to the low-voltage installation. This category refers to local-level distribution, such as that provided by a standard wall outlet.

Specifications

The following specifications are typical for the range -40 to 70 °C unless otherwise noted. Specifications are subject to change in future revisions of this manual.

Input Characteristics

Number of channels	8
ADC resolution	16 bits
Type of ADC	Delta-sigma
Voltage measurement range	-20 to 80 mV
All-channel update period	0.22 – 0.99 s (varies with per-channel filter settings)
Input bandwidth	
Filter enabled	12 Hz
Filter disabled	45 Hz
DC crosstalk	100 dB
Normal-mode noise rejection (50/60 Hz)	85 dB (with filter enabled)
Maximum common-mode voltage between channels and between any channel and earth ground ¹	250 V (DC or RMS)
DC common-mode rejection ratio between channels	160 dB minimum; 170 dB typical
50/60 Hz common-mode rejection ratio between channels	
Filter enabled	160 dB minimum; 170 dB typical
Filter disabled	100 dB minimum; 110 dB typical
Common-mode rejection ratio referenced to earth (DC and 50/60 Hz)	170 dB
Overvoltage protection	± 250 V (DC or RMS)

¹ Refer to the [Safety Isolation Voltage](#) section for information about common-mode voltage referenced to earth ground.

Input impedance

Filter enabled.....	18 M Ω minimum; >80 M Ω typical
Filter disabled.....	1 M Ω minimum; >5 M Ω typical

Input current

Filter enabled.....	5 nA maximum; <1 nA typical
Filter disabled.....	45 nA maximum; <16 nA typical

Input noise (RMS)

Filter enabled.....	$\pm 0.75 \mu\text{V}$
Filter disabled.....	$\pm 3 \mu\text{V}$

Accuracy for -20 to 80 mV input range (full scale is 80 mV)¹

50/60 Hz Filter Setting	Typical Accuracy at 15 to 35 °C (% of Reading; % of Full Scale)	Warranted Accuracy at 15 to 35 °C (% of Reading; % of Full Scale)
Enabled	$\pm 0.021\%$; $\pm 0.010\%$	$\pm 0.035\%$; $\pm 0.016\%$
Disabled	$\pm 0.025\%$; $\pm 0.016\%$	$\pm 0.045\%$; $\pm 0.048\%$

50/60 Hz Filter Setting	Typical Accuracy at -40 to 70 °C (% of Reading; % of Full Scale)	Warranted Accuracy at -40 to 70 °C (% of Reading; % of Full Scale)
Enabled	$\pm 0.048\%$; $\pm 0.015\%$	$\pm 0.107\%$; $\pm 0.033\%$
Disabled	$\pm 0.055\%$; $\pm 0.041\%$	$\pm 0.13\%$; $\pm 0.12\%$

Gain drift..... 6 ppm/°C typical;
15 ppm/°C maximum

Offset drift

Filter enabled.....	60 nV/°C typical; 120 nV/°C maximum
Filter disabled.....	380 nV/°C typical; 1070 nV/°C maximum

¹ For thermocouple measurement accuracy, refer to the charts in the [Determining Measurement Accuracy and Minimizing Errors](#) section.

Nonlinearity (INL)..... $\pm 0.003\%$ typical;
 $\pm 0.006\%$ maximum

Cold-junction accuracy

Typical at 25 °C..... 0.25 °C

Typical over full range..... 0.5 °C

Maximum over full range..... 1.1 °C



Note There can be an additional difference, typically 0.2 °C, between the temperature of the cold-junction sensor and that of the terminals in the cFP-CB-3.

Temperature measurement ranges

Thermocouple Type	Valid Range
J	-210 to 1,200 °C
K	-270 to 1,372 °C
R	-50 to 1,768 °C
S	-50 to 1,768 °C
T	-270 to 400 °C
N	-270 to 1,300 °C
E	-270 to 1,000 °C
B	40 to 1,770 °C

Physical Characteristics

Indicators Two green LEDs for **POWER** and **READY**;
eight red LEDs for open thermocouple detected

Weight..... 125 g (4.4 oz)

Power Requirements

Power from network module 650 mW maximum

Safety Isolation Voltage

Isolation voltage is verified by a dielectric withstand test.

Channel to ground

Continuous 250 V_{rms}, Measurement
Category II

Withstand..... 2,300 V_{rms}, 5 s max

Channel to channel None

Environmental

FieldPoint modules are intended for indoor use only. For outdoor use, they must be mounted inside a sealed enclosure.

Operating temperature -40 to 70 °C

Storage temperature -40 to 85 °C

Humidity 10 to 90% RH,
noncondensing

Maximum altitude..... 2,000 m; at higher altitudes
the isolation voltage ratings
must be lowered.

Pollution Degree 2

Shock and Vibration

Operating vibration, random
(IEC 60068-2-64)..... 10–500 Hz, 5 g_{rms}

Operating vibration, sinusoidal
(IEC 60068-2-6)..... 10–500 Hz, 5 g

Operating shock
(IEC 60068-2-27)..... 50 g, 3 ms half sine,
18 shocks at 6 orientations;
30 g, 11 ms half sine,
18 shocks at 6 orientations

Safety

This product is designed to meet the requirements of the following standards of safety for electrical equipment for measurement, control, and laboratory use:

- IEC 61010-1, EN-61010-1
- UL 61010-1, CAN/CSA-C22.2 No. 61010-1



Note For UL and other safety certifications, refer to the product label or visit ni.com/certification, search by model number or product line, and click the appropriate link in the Certification column.

Electromagnetic Compatibility

This product is designed to meet the requirements of the following standards of EMC for electrical equipment for measurement, control, and laboratory use:

- EN 61326 EMC requirements; Industrial Immunity
- EN 55011 Emissions; Group 1, Class A
- CE, C-Tick, ICES, and FCC Part 15 Emissions; Class A



Caution EN 61326 prescribes testing radiated immunity in the presence of electromagnetic fields with a magnitude of 10 V/m. The cFP-TC-125 may exhibit up to 40 times the specified error in the presence of 10 V/m fields between 80 MHz and 350 MHz.

CE Compliance

This product meets the essential requirements of applicable European Directives, as amended for CE marking, as follows:

- 73/23/EEC; Low-Voltage Directive (safety)
- 89/336/EEC; Electromagnetic Compatibility Directive (EMC)



Note Refer to the Declaration of Conformity (DoC) for this product for any additional regulatory compliance information. To obtain the DoC for this product, visit ni.com/certification, search by model number or product line, and click the appropriate link in the Certification column.

Waste Electrical and Electronic Equipment (WEEE)



EU Customers At the end of their life cycle, all products *must* be sent to a WEEE recycling center. For more information about WEEE recycling centers and National Instruments WEEE initiatives, visit ni.com/environment/weee.htm.

Where to Go for Support

For more information about setting up the FieldPoint system, refer to these National Instruments documents:

- FieldPoint network module user manual
- Other FieldPoint I/O module operating instructions
- Compact FieldPoint connector block operating instructions

Go to ni.com/support for the most current manuals, examples, and troubleshooting information.

National Instruments corporate headquarters is located at 11500 North Mopac Expressway, Austin, Texas, 78759-3504. National Instruments also has offices located around the world to help address your support needs. For telephone support in the United States, create your service request at ni.com/support and follow the calling instructions or dial 512 795 8248. For telephone support outside the United States, contact your local branch office:

Australia 1800 300 800, Austria 43 0 662 45 79 90 0,
Belgium 32 0 2 757 00 20, Brazil 55 11 3262 3599,
Canada 800 433 3488, China 86 21 6555 7838,
Czech Republic 420 224 235 774, Denmark 45 45 76 26 00,
Finland 385 0 9 725 725 11, France 33 0 1 48 14 24 24,
Germany 49 0 89 741 31 30, India 91 80 41190000,
Israel 972 0 3 6393737, Italy 39 02 413091,
Japan 81 3 5472 2970, Korea 82 02 3451 3400,
Lebanon 961 0 1 33 28 28, Malaysia 1800 887710,
Mexico 01 800 010 0793, Netherlands 31 0 348 433 466,
New Zealand 0800 553 322, Norway 47 0 66 90 76 60,
Poland 48 22 3390150, Portugal 351 210 311 210,
Russia 7 095 783 68 51, Singapore 1800 226 5886,
Slovenia 386 3 425 4200, South Africa 27 0 11 805 8197,
Spain 34 91 640 0085, Sweden 46 0 8 587 895 00,
Switzerland 41 56 200 51 51, Taiwan 886 02 2377 2222,
Thailand 662 278 6777, United Kingdom 44 0 1635 523545

National Instruments, NI, ni.com, and LabVIEW are trademarks of National Instruments Corporation. Refer to the *Terms of Use* section on ni.com/legal for more information about National Instruments trademarks. Other product and company names mentioned herein are trademarks or trade names of their respective companies. For patents covering National Instruments products, refer to the appropriate location: **Help»Patents** in your software, the `patents.txt` file on your CD, or ni.com/patents.

© 2006 National Instruments Corp. All rights reserved.