

COMPREHENSIVE SERVICES

We offer competitive repair and calibration services, as well as easily accessible documentation and free downloadable resources.

SELL YOUR SURPLUS

We buy new, used, decommissioned, and surplus parts from every NI series. We work out the best solution to suit your individual needs.

 Sell For Cash  Get Credit  Receive a Trade-In Deal

OBSOLETE NI HARDWARE IN STOCK & READY TO SHIP

We stock **New**, **New Surplus**, **Refurbished**, and **Reconditioned** NI Hardware.



Bridging the gap between the manufacturer and your legacy test system.

 1-800-915-6216

 www.apexwaves.com

 sales@apexwaves.com

All trademarks, brands, and brand names are the property of their respective owners.

Request a Quote

 **CLICK HERE**

cFP-RLY-421

FieldPoint Operating Instructions

cFP-RLY-421

Eight-Channel SPST Relay Module

These operating instructions describe how to install and use the National Instruments cFP-RLY-421 relay module, revision 185151C-01 and later. For information about installing and using earlier revisions of the cFP-RLY-421, refer to document number 323617B-01. Earlier revisions of the cFP-RLY-421 display the following symbol on the module label:  .

For information about configuring and accessing the cFP-RLY-421 over a network, refer to the user manual for the FieldPoint network module you are using.

Features

The cFP-RLY-421 is a Compact FieldPoint relay output module with the following features:

- Eight single-pole single-throw (SPST) relay channels
- Switches up to 1.5 A at 40 VDC or 250 VAC
- -40 to 55 °C operation
- 250 V_{rms} CAT II continuous channel-to-ground isolation, verified by 2,300 V_{rms}, 5 s dielectric withstand test
- Hot swappable

Installing the cFP-RLY-421

The cFP-RLY-421 mounts on a Compact FieldPoint backplane (cFP-BP-*x*), which provides operating power to the module. Installing the cFP-RLY-421 onto a powered backplane does not disrupt the operation of the bank.

To install the cFP-RLY-421, refer to Figure 1 and complete the following steps:

1. Align the captive screws on the cFP-RLY-421 with the holes on the backplane. The alignment keys on the cFP-RLY-421 prevent backward insertion.
2. Press firmly to seat the cFP-RLY-421 on the backplane.
3. Using a number 2 Phillips screwdriver with a shank of at least 64 mm (2.5 in.) length, tighten the captive screws to $1.1 \text{ N} \cdot \text{m}$ (10 lb · in.) of torque. The nylon coating on the screws prevents them from loosening.

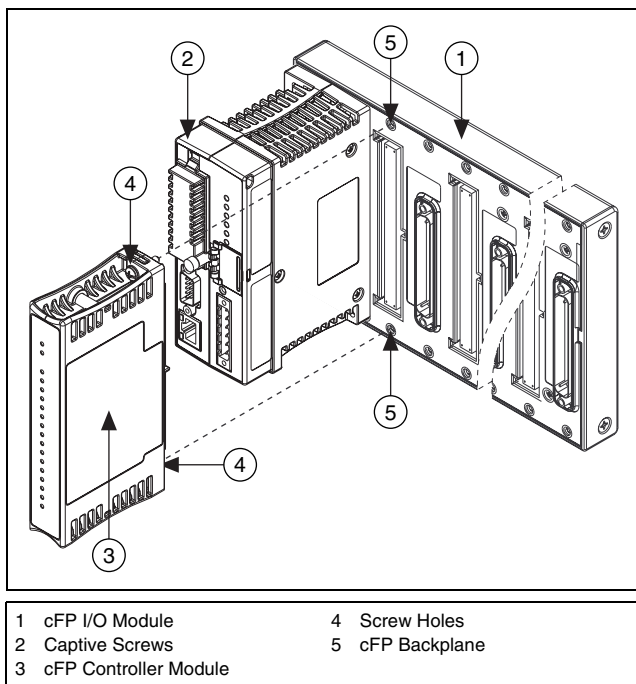

Figure 1. Installing the cFP-RLY-421

Wiring the cFP-RLY-421

The cFP-CB-*x* connector block has connections for each of the eight cFP-RLY-421 relay channels and for an external supply to power field devices. If you are using the cFP-RLY-421 in a *hazardous voltage* application, you must use the cFP-CB-1 connector block or a suitable hazardous voltage cable. A hazardous voltage is a voltage greater than $42.4 V_{\text{peak}}$ or 60 VDC.



Caution Ensure that hazardous voltage wiring is performed only by qualified personnel adhering to local electrical standards.

Each relay channel of the cFP-RLY-421 has two terminals: one NO (normally open) and one IC (isolated common).

Table 1 lists the terminal assignments for the signals of each channel.

Table 1. Terminal Assignments

Channel	Terminal Numbers	
	NO	IC
0	1	2
1	3	4
2	5	6
3	7	8
4	9	10
5	11	12
6	13	14
7	15	16

All of the COM terminals are connected internally and all of the V_{SUP} terminals are connected internally. NI does not recommend using the V_{SUP} and COM terminals with the cFP-RLY-421.

Table 2. V_{SUP} and COM Terminal Assignments

V_{SUP}	COM
17	18
19	20
21	22
23	24
25	26
27	28
29	30
31	32



Caution Cascading power between two modules defeats isolation between those modules. Cascading power from the network module defeats all isolation between modules in the FieldPoint bank.

Connecting Loads to the cFP-RLY-421

Wire an external power supply to the load and the IC terminal of the individual channel as shown in Figure 2. Install a 1.5 A, 250 V maximum, fast-acting fuse suitable for the load at the IC terminal to protect the module and the load from damage.

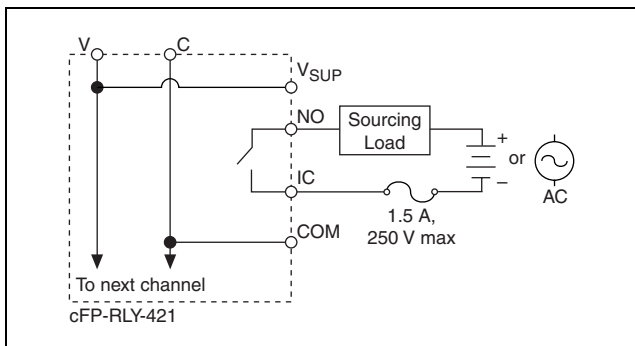
**Figure 2.** Connecting a Load

The cFP-RLY-421 has eight SPST electromechanical relays. The power-up state is off (open) to ensure safe installation. In the ON

state, the NO and IC contacts connect to form a short circuit. In the ON state, there is an effective resistance of up to 150 m Ω between the NO and IC terminals, which causes a voltage drop.¹ For example, if the current is 1.5 A, the voltage drop across the NO and IC terminals can be as high as 0.225 V.

The amount of current the relay can switch depends on the voltage, the type of load, and the ambient temperature. Refer to the [Specifications](#) section for more information.

Protecting Contacts for Inductive Loads

When an inductive load is connected to a relay, the energy stored in the inductive load can produce a large counter-electromotive force when the relay switches. This *flyback voltage* can severely damage the relay contacts and greatly shorten the life of the relay.

It is best to limit flyback voltages by installing a flyback diode across an inductive DC load or a metal oxide varistor (MOV) across an inductive AC load.

The cFP-RLY-421 has internal protection MOVs to prevent excessively high voltage from being applied across the contacts. The MOVs are located between the NO and IC contacts of each relay. However, National Instruments recommends installing protection circuits across inductive loads. The flyback protection causes a small leakage current, which is detailed in the [Specifications](#) section.

Refer to the *NI Switches Help* for information about selecting and installing contact protection circuits. Go to ni.com/manuals, search for **switches help**, and select the current version of the *NI Switches Help*.

Status Indicators

After you install the cFP-RLY-421 onto a backplane and apply power to the network module, the green **POWER** indicator lights and the cFP-RLY-421 informs the network module of its presence. When the network module recognizes the cFP-RLY-421, it sends initial configuration information to the cFP-RLY-421. After the cFP-RLY-421 receives this initial information, the green **READY** indicator lights and the module is in normal operating mode.

¹ At the end of relay life, the path resistance rises rapidly above 1 Ω .

In addition to the green **POWER** and **READY** indicators, each channel has a numbered, green output state indicator that lights when the channel is in the ON state.

Isolation and Safety Guidelines



Caution Read the following information before attempting to connect the cFP-RLY-421 to any circuits that may contain hazardous voltages.

This section describes the isolation of the cFP-RLY-421 and its compliance with international safety standards. The field wiring connections are isolated from the backplane and the inter-module communication bus. The isolation barriers in the module provide 250 V_{rms} Measurement Category II continuous isolation, verified by 2,300 V_{rms}, 5 s dielectric withstand test. The cFP-RLY-421 provides *double insulation* (compliant with IEC 61010-1) for working voltages of 250 V_{rms}¹. Safety standards (such as those published by UL and IEC) require the use of double insulation between hazardous voltages and any human-accessible parts or circuits.

Never try to use any isolation product between human-accessible parts (such as DIN rails or monitoring stations) and circuits that can be at hazardous potentials under normal conditions, unless the product is specifically designed for such an application, as is the cFP-RLY-421.

Even though the cFP-RLY-421 is designed to handle applications with hazardous potentials, follow these guidelines to ensure a safe system:

- As with any hazardous voltage wiring, make sure that all wiring and connections meet applicable electrical codes and commonsense practices. Mount terminal bases and backplanes in an area, position, or cabinet that prevents accidental or unauthorized access to wiring that carries hazardous voltages.
- Do *not* use the cFP-RLY-421 as the only isolating barrier between human contact and working voltages higher than 250 V_{rms}.

¹ *Working voltage* is defined as the signal voltage plus the common-mode voltage. *Common-mode voltage* is the voltage of the module with respect to ground.

- When hazardous voltages are present on any channel, all channels must be considered hazardous. Ensure that external wiring and all circuits connected to the device are properly insulated from human contact.
- Operate the cFP-RLY-421 only at or below Pollution Degree 2. Pollution Degree 2 means that only nonconductive pollution occurs in most cases. Occasionally, however, condensation can cause temporary conductivity.
- You *must* connect the protective earth (PE) ground terminal on the cFP-BP-*x* backplane to the system safety ground. The backplane PE ground terminal has the following symbol stamped beside it: \oplus . Connect the backplane PE ground terminal to the system safety ground using 14 AWG (1.6 mm) wire with a ring lug. Use the 5/16 in. panhead screw shipped with the backplane to secure the ring lug to the backplane PE ground terminal.
- The cFP-RLY-421 is a UL Recognized component. The entire Compact FieldPoint system must be installed in a UL Listed, suitably rated NEMA or IP enclosure for safe use.

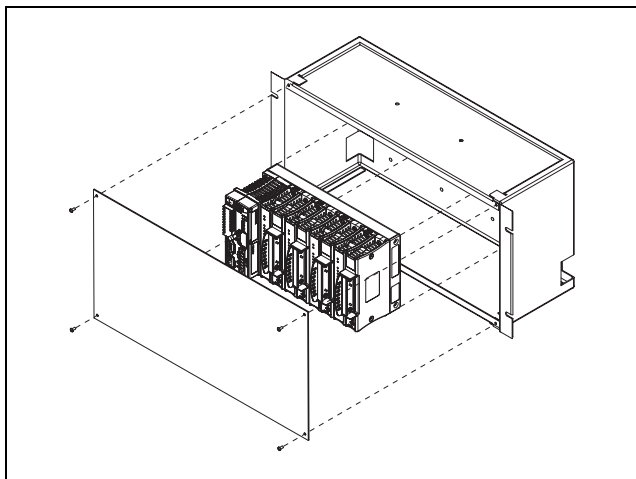

Figure 3. Installing the Compact FieldPoint System in an Enclosure

- Operate the cFP-RLY-421 at or below Measurement Category II. Measurement Category II is for measurements performed on circuits directly connected to the low-voltage installation. This category refers to local-level distribution,

such as that provided by a standard wall outlet. Do not use this module with voltages in Measurement Categories III or IV.

Using This Product Safely in Hazardous Locations

This product is suitable for use in U.S. and Canada: Class I, Division 2, Groups A, B, C, D, T4 hazardous locations; and nonhazardous locations.



Cautions Explosion hazard—Substitution of components may impair suitability for Class I, Division 2.

Explosion hazard—Do not disconnect equipment unless power has been switched off or the area is known to be nonhazardous.

Equipment must be used within its electrical and environmental ratings. Refer to the *Specifications* section. Refer to the product label for manufacturing location.

This product must be installed in an enclosure rated at least IP 54.

Specifications

The following specifications are typical for a range of -40 to 55 °C unless otherwise noted. All specifications are subject to change without notice.

Relay Characteristics

Number of channels	8
Relay type	SPST, nonlatching, normally open
Maximum switching capacity per channel (resistive load)	
At 250 VAC	1.5 A at -40 to 45 °C 1.0 A at 45 to 55 °C
At 40 VDC	1.5 A at -40 to 45 °C 1.0 A at 45 to 55 °C
At 60 VDC	1.0 A
At 120 VDC	0.4 A
Minimum switching load	10 mA at 5 VDC

Maximum switching power

AC 375 VA

DC 60 W

DC path resistance

Initial 150 m Ω

End of life $\geq 1 \Omega$



Note DC path resistance typically remains low for the life of the relay. At the end of relay life, the path resistance rises rapidly above 1 Ω . Load ratings apply to relays used within the specification before the end of relay life.

Off-state leakage

At 250 VAC 8 μ A

At 120 VDC 0.12 μ A

Expected life

Mechanical 2×10^7 operations min

Electrical 100,000 operations

Maximum switching frequency

Mechanical 20 operations per second

Electrical 1 operation per second at maximum load

Relay operate time 8 ms

Relay release time 4 ms

Relay bounce time 4 ms

Contact material Gold-plated silver
cadmium oxide

Physical

Indicators Green **POWER** and **READY** indicators, 8 green output state indicators

Weight 137 g (4.8 oz)

Power Requirements

Power from network module 1 W max

Safety Isolation Voltage

Isolation voltage is verified by a dielectric withstand test.

Channel to backplane

Continuous 250 V_{rms}

Withstand..... 2,300 V_{rms}, 5 s max

Channel to ground

Continuous 250 V_{rms}

Withstand..... 2,300 V_{rms}, 5 s max

Channel to channel No isolation

Environmental

Compact FieldPoint modules are intended for indoor use only.

For outdoor use, they must be mounted inside a sealed enclosure.

Operating temperature -40 to 55 °C

Storage temperature -55 to 85 °C

Humidity 10 to 85% RH,
noncondensing

Maximum altitude..... 2,000 m; at higher altitudes
the isolation voltage ratings
must be lowered

Pollution Degree 2

Safety

This product is designed to meet the requirements of the following standards of safety for electrical equipment for measurement, control, and laboratory use:

- IEC 61010-1, EN 61010-1
- UL 61010-1
- CAN/CSA-C22.2 No. 61010-1

For UL, hazardous location, and other safety certifications, refer to the product label or visit ni.com/certification, search by model number or product line, and click the appropriate link in the Certification column.

Electromagnetic Compatibility

Emissions.....	EN 55011 Class A at 10 m FCC Part 15A above 1 GHz
Immunity.....	EN 61326:1997 + A2:2001, Table 1

CE, C-Tick, and FCC Part 15 (Class A) Compliant

CE Compliance

This product meets the essential requirements of applicable European Directives, as amended for CE marking, as follows:

Low-Voltage Directive (safety).....	73/23/EEC
Electromagnetic Compatibility Directive (EMC)	89/336/EEC



Note Refer to the Declaration of Conformity (DoC) for this product for any additional regulatory compliance information. To obtain the DoC for this product, visit ni.com/certification, search by model number or product line, and click the appropriate link in the Certification column.

Where to Go for Support

For more information about setting up the Compact FieldPoint system, refer to these National Instruments documents:

- Compact FieldPoint network module user manual
- Other Compact FieldPoint I/O module operating instructions
- Compact FieldPoint connector block operating instructions

Go to ni.com/support for the most current manuals, examples, and troubleshooting information.

National Instruments corporate headquarters is located at 11500 North Mopac Expressway, Austin, Texas, 78759-3504. National Instruments also has offices located around the world to help address your support needs. For telephone support in the United States, create your service request at ni.com/support and follow the calling instructions or dial 512 795 8248. For telephone support outside the United States, contact your local branch office:

Australia 1800 300 800, Austria 43 0 662 45 79 90 0,
Belgium 32 0 2 757 00 20, Brazil 55 11 3262 3599,
Canada 800 433 3488, China 86 21 6555 7838,
Czech Republic 420 224 235 774, Denmark 45 45 76 26 00,
Finland 385 0 9 725 725 11, France 33 0 1 48 14 24 24,
Germany 49 0 89 741 31 30, India 91 80 51190000,
Israel 972 0 3 6393737, Italy 39 02 413091,
Japan 81 3 5472 2970, Korea 82 02 3451 3400,
Lebanon 961 0 1 33 28 28, Malaysia 1800 887710,
Mexico 01 800 010 0793, Netherlands 31 0 348 433 466,
New Zealand 0800 553 322, Norway 47 0 66 90 76 60,
Poland 48 22 3390150, Portugal 351 210 311 210,
Russia 7 095 783 68 51, Singapore 1800 226 5886,
Slovenia 386 3 425 4200, South Africa 27 0 11 805 8197,
Spain 34 91 640 0085, Sweden 46 0 8 587 895 00,
Switzerland 41 56 200 51 51, Taiwan 886 02 2377 2222,
Thailand 662 278 6777, United Kingdom 44 0 1635 523545

National Instruments, NI, ni.com, and LabVIEW are trademarks of National Instruments Corporation. Refer to the *Terms of Use* section on ni.com/legal for more information about National Instruments trademarks. Other product and company names mentioned herein are trademarks or trade names of their respective companies. For patents covering National Instruments products, refer to the appropriate location: **Help»Patents** in your software, the `patents.txt` file on your CD, or ni.com/patents.

© 2003–2005 National Instruments Corp. All rights reserved.