

COMPREHENSIVE SERVICES

We offer competitive repair and calibration services, as well as easily accessible documentation and free downloadable resources.

SELL YOUR SURPLUS

We buy new, used, decommissioned, and surplus parts from every NI series. We work out the best solution to suit your individual needs.

 Sell For Cash  Get Credit  Receive a Trade-In Deal

OBSOLETE NI HARDWARE IN STOCK & READY TO SHIP

We stock **New**, **New Surplus**, **Refurbished**, and **Reconditioned** NI Hardware.



Bridging the gap between the manufacturer and your legacy test system.

 1-800-915-6216

 www.apexwaves.com

 sales@apexwaves.com

All trademarks, brands, and brand names are the property of their respective owners.

Request a Quote

 **CLICK HERE**

cRIO-9068

NI CMS-9068 and NI MMS-9068

NI Condition Monitoring System and NI Motor Monitoring System for NI InsightCM™ Enterprise

This document describes how to maintain the CMS-9068 NI Condition Monitoring System and the MMS-9068 NI Motor Monitoring System. Both the CompactRIO-based CMS-9068 and the CompactRIO-based MMS-9068 are bundles of hardware and software that include the following components and features:

- cRIO-9068 integrated controller and chassis
- NI C Series modules installed in the chassis
- Pre-installed NI InsightCM Server software
- Network configuration via USB drive



Note Complete the steps in the *NI InsightCM Enterprise Monitoring System Quick Start* before using this document.



Note The chassis and modules included in the CMS/MMS-9068 have been individually certified and rated for safety, environmental, and regulatory information. Refer to ni.com/manuals for complete hardware documentation for each device, including safety, environmental, and regulatory information.

Contents

Controller Front Panel.....	2
Mounting the Device.....	3
Dimensions.....	3
Mounting Requirements.....	4
Ambient Temperature.....	5
Mounting the Device Directly on a Flat Surface.....	6
Mounting the Device on a Panel.....	7
Mounting the Device on a DIN Rail.....	9
Mounting the Device on a Rack.....	10
Mounting the Device on a Desktop.....	10
Installing C Series I/O Modules in the Chassis.....	12
I/O Module Arrangements	13
Removing I/O Modules from the Chassis.....	15
Connecting to a Network.....	15
Grounding the Chassis.....	15

Wiring Power to the Controller.....	16
Powering On the Controller.....	17
Understanding LED Indications on the Controller.....	17
POWER LED.....	18
STATUS LED.....	18
USER1 LED.....	18
USER FPGA1 LED.....	18
Troubleshooting Network Communication.....	18
Resetting the Network Configuration of the Controller.....	19
Where to Go Next.....	20
Worldwide Support and Services.....	20

Controller Front Panel

The following figure shows the I/O ports and other features of the cRIO-9068 controller.

Figure 1. cRIO-9068 Controller Front Panel

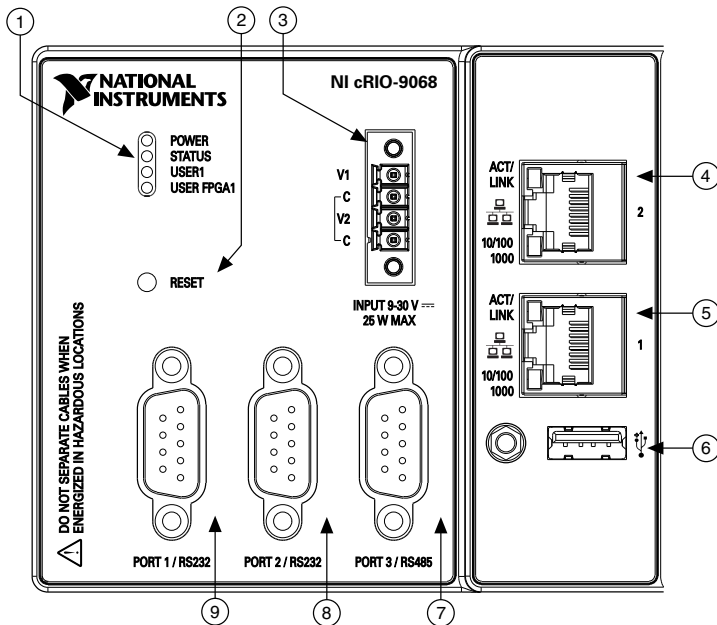

- | | |
|--------------------------|-----------------------|
| 1. LEDs | 6. USB port |
| 2. Reset button | 7. RS-485 Serial port |
| 3. Power connector | 8. RS-232 Serial port |
| 4. RJ-45 Ethernet port 2 | 9. RS-232 Serial port |
| 5. RJ-45 Ethernet port 1 | |

Mounting the Device

To obtain the maximum allowable ambient temperature of 70 °C, you must mount the CMS/MMS-9068 horizontally on a flat, metallic, vertical surface such as a panel or wall. You can mount the CMS/MMS-9068 directly to the surface or use the NI Panel Mounting Kit. The following figure shows the CMS/MMS-9068 mounted horizontally.

Figure 2. CMS/MMS-9068 Horizontal Mounting

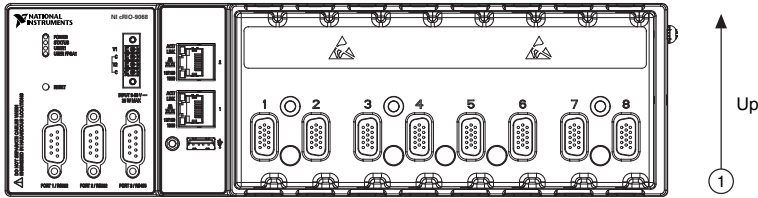

1. Up

You can also mount the CMS/MMS-9068 in other orientations, on a nonmetallic surface, on a 35-mm DIN rail, on a desktop, or in a rack. Mounting the CMS/MMS-9068 in these or other configurations can reduce the maximum allowable ambient temperature and can affect the typical accuracy of modules in the CMS/MMS-9068. For more information about typical accuracy specifications for C Series modules and temperature deratings caused by different mounting configurations, visit ni.com/info and enter the Info Code `criotypical`.



Caution Make sure that no C Series modules are in the CMS/MMS-9068 before mounting it.



Tip Before using any of these mounting methods, record the serial number from the back of the CMS/MMS-9068 so that you can identify the CMS/MMS-9068 in NI InsightCM Systems Manager. You will be unable to read the serial number after you mount the CMS/MMS-9068.

Dimensions

The following figures show the front and side dimensions of the CMS/MMS-9068. For detailed dimensional drawings and 3D models, visit ni.com/dimensions and search for the module number.

Figure 3. CMS/MMS-9068 Front Dimensions

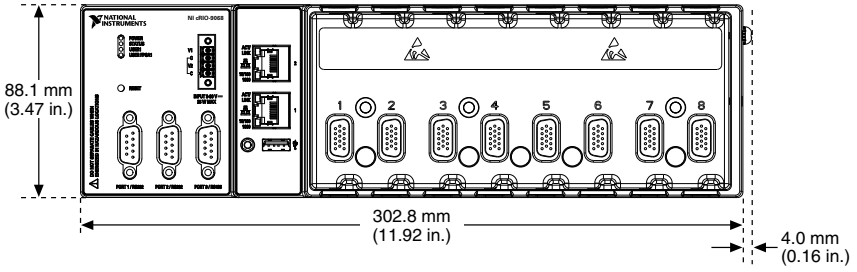
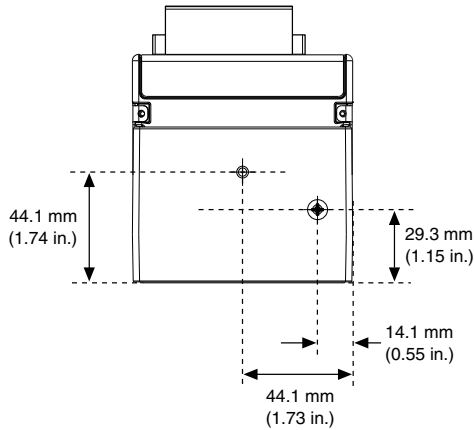

Figure 4. CMS/MMS-9068 Side Dimensions



Mounting Requirements

Your installation must meet the following requirements for cooling and cabling clearance.

Allow 50.8 mm (2 in.) on the top and the bottom of the CMS/MMS-9068 for air circulation, as shown in the following figure.

Figure 5. CMS/MMS-9068 Cooling Dimensions

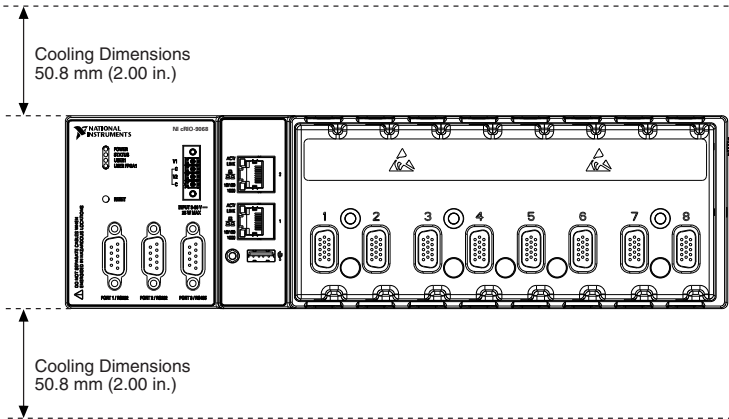

Allow the appropriate space in front of C Series modules for cabling clearance, as shown in the following figure. The different connector types on C Series modules require different cabling clearances. For a complete list of cabling clearances for C Series modules, visit ni.com/info and enter the Info Code `crioconn`.

Figure 6. CMS/MMS-9068 Cabling Clearance

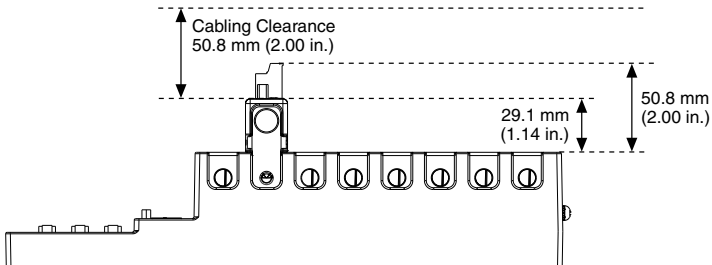

Ambient Temperature

Measure the ambient temperature at each side of the CMS/MMS-9068, 63.5 mm (2.5 in.) from the side and 25.4 mm (1 in.) forward from the rear of the CMS/MMS-9068, as shown in the following figure.

Figure 7. CMS/MMS-9068 Ambient Temperature Location

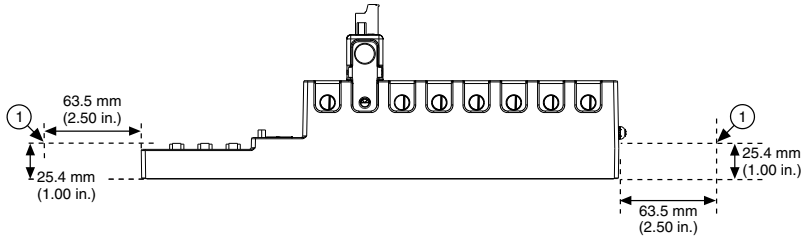

1. Location for measuring the ambient temperature

Mounting the Device Directly on a Flat Surface

For environments with high shock and vibration, NI recommends mounting the CMS/MMS-9068 directly on a flat, rigid surface using the mounting holes in the CMS/MMS-9068.

What to Use

- CMS/MMS-9068
- Screwdriver, Phillips #2
- M4 or number 8 screw (x3), user-provided, longer than 19 mm (0.75 in.) to pass all the way through the CMS/MMS-9068

What to Do

Complete the following steps to mount the CMS/MMS-9068 directly on a flat surface.

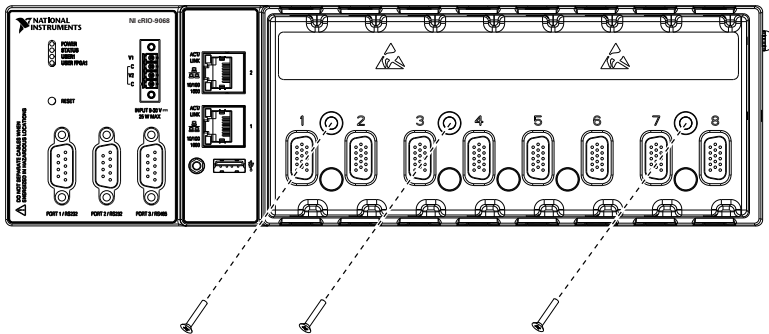

1. Prepare the surface for mounting the CMS/MMS-9068 using the [Surface Mounting Dimensions](#).
2. Align the CMS/MMS-9068 on the surface.
3. Fasten the CMS/MMS-9068 to the surface using the M4 or number 8 screws appropriate for the surface. Tighten the screws to a maximum torque of 1.3 N · m (11.5 lb · in.).

Surface Mounting Dimensions

The following figure shows the surface mounting dimensions for the CMS/MMS-9068.

Figure 8. CMS/MMS-9068 Surface Mounting Dimensions

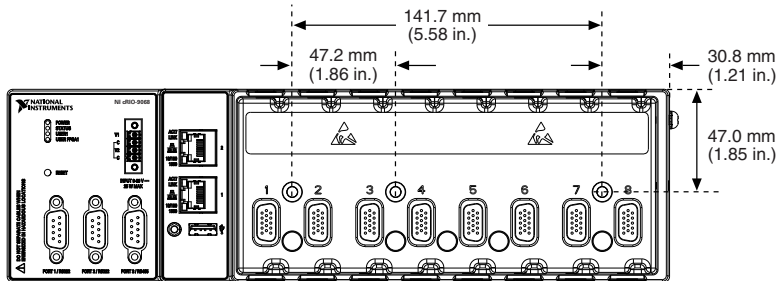

Mounting the Device on a Panel

You can use the NI panel mounting kit to mount the CMS/MMS-9068 on a panel.

What to Use

- CMS/MMS-9068
- Screwdriver, Phillips #2
- NI panel mounting kit, 782863-01
 - Panel mounting plate
 - M4 × 23 screw (x3)

What to Do

Complete the following steps to mount the CMS/MMS-9068 on a panel.

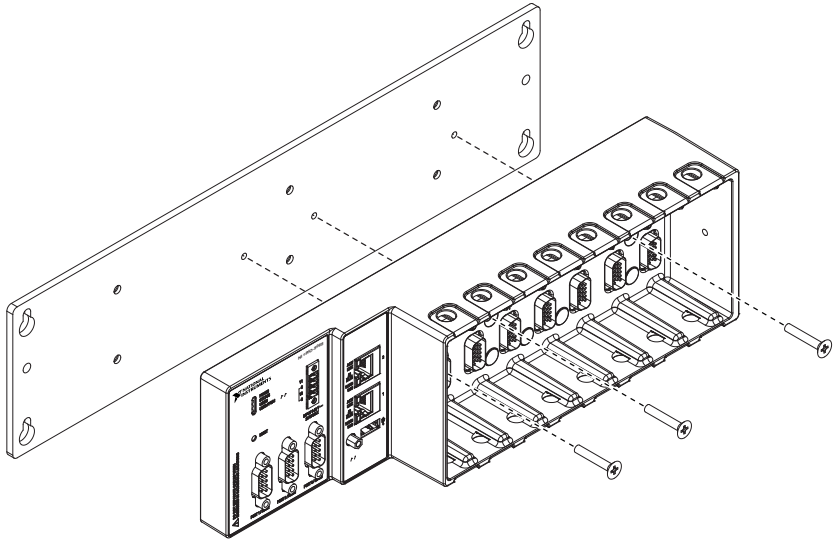

1. Align the CMS/MMS-9068 and the panel mounting plate.
2. Fasten the panel mounting plate to the CMS/MMS-9068 using the screwdriver and M4 × 23 screws. NI provides these screws with the panel mounting kit. Tighten the screws to a maximum torque of 1.3 N · m (11.5 lb · in.).



Note You must use the screws provided with the NI panel mounting kit because they are the correct depth and thread for the panel mounting plate.

3. Fasten the panel mounting plate to the surface using the screwdriver and screws that are appropriate for the surface. The maximum screw size is M5 or number 10.

Panel Mounting Dimensions

The following figure shows the panel mounting dimensions for the CMS/MMS-9068.

Figure 9. CMS/MMS-9068 Panel Mounting Dimensions

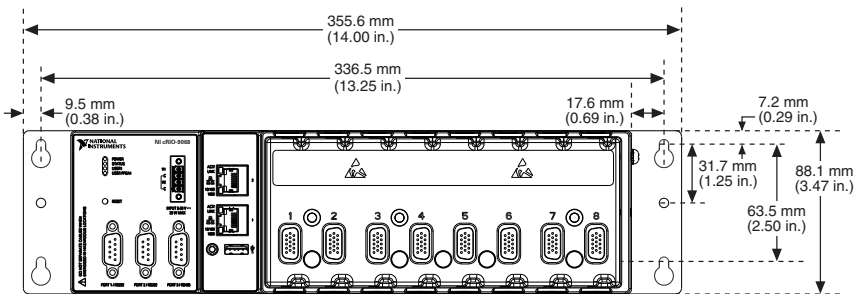

Mounting the Device on a DIN Rail

You can use the NI DIN rail mounting kit to mount the CMS/MMS-9068 on a standard 35-mm DIN rail.

What to Use

- CMS/MMS-9068
- Screwdriver, Phillips #2
- NI DIN rail mounting kit, 779018-01
 - DIN rail clip
 - M4 × 25 flathead screw (x2)

What to Do

Complete the following steps to mount the CMS/MMS-9068 on a DIN rail.

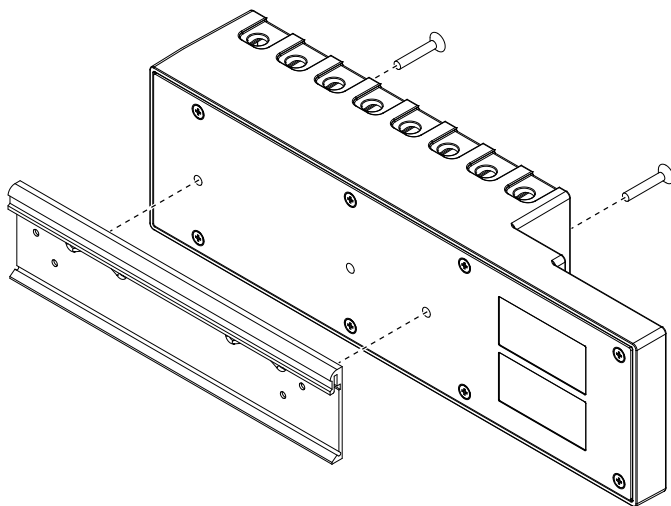

1. Align the CMS/MMS-9068 and the DIN rail clip.
2. Fasten the DIN rail kit to the CMS/MMS-9068 using the screwdriver and M4 × 25 flathead screws. NI provides these screws with the DIN rail mounting kit. Tighten the screws to a maximum torque of 1.3 N · m (11.5 lb · in.).



Note You must use the screws provided with the NI DIN rail mounting kit because they are the correct depth and thread for the DIN rail clip.

Clipping the Device on a DIN Rail

Complete the following steps to clip the CMS/MMS-9068 on a DIN rail.

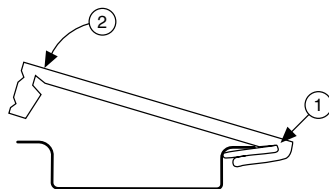

1. Insert one edge of the DIN rail into the deeper opening of the DIN rail clip.
2. Press down firmly to compress the spring until the clip locks in place on the DIN rail.



Caution Ensure that no C Series modules are in the CMS/MMS-9068 before removing it from the DIN rail.

Mounting the Device on a Rack

You can use the following rack mount kits to mount the CMS/MMS-9068 and other DIN rail-mountable equipment on a standard 482.6 mm (19 in.) rack.

- NI Sliding Rack-Mounting Kit, 779102-01
- NI Rack-Mounting Kit, 781989-01



Note You must use the NI DIN rail mounting kit, 779018-01, in addition to a rack-mounting kit.

Mounting the Device on a Desktop

You can use the NI desktop mounting kit to mount the CMS/MMS-9068 on a desktop.

What to Use

- CMS/MMS-9068
- Screwdriver, Phillips #1
- Screwdriver, Phillips #2
- NI desktop mounting kit, 779473-01
 - Desktop mounting brackets (x2)
 - Adapter bracket
 - M3 × 20 screw (x2)

What to Do

Complete the following steps to mount the CMS/MMS-9068 on a desktop.

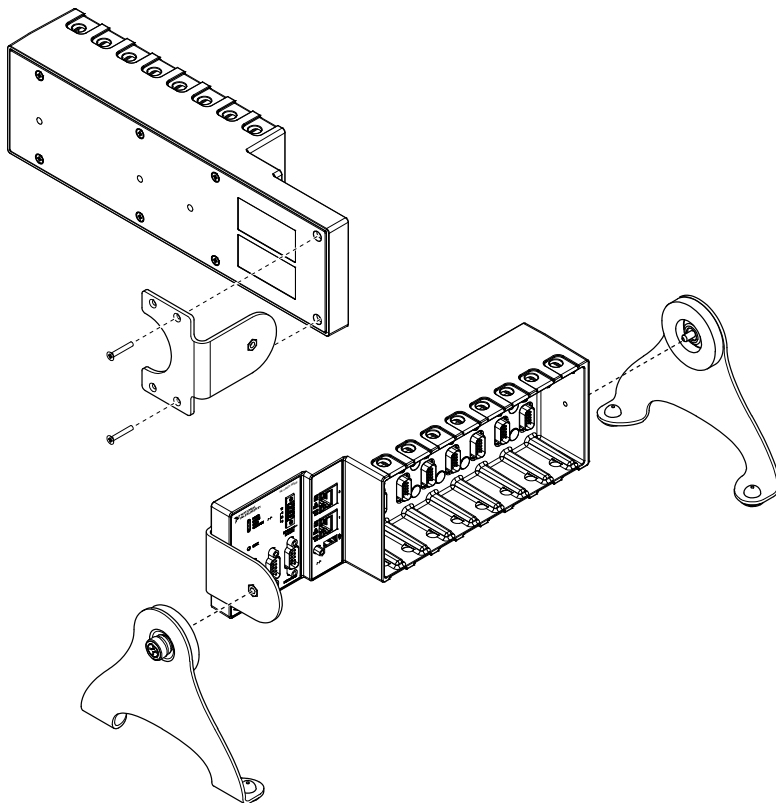

1. Use the Phillips #1 screwdriver to remove the two screws from the back of the CMS/MMS-9068.
2. Use the screwdriver and the M3 × 20 screws to attach the adapter bracket to the CMS/MMS-9068. NI provides these screws with the desktop mounting kit.



Note You must use the screws provided with the NI desktop mounting kit because they are the correct depth and thread for the CMS/MMS-9068.

3. Align the brackets with the mounting holes on the ends of the CMS/MMS-9068.
4. Use the Phillips #2 screwdriver to tighten the captive screws on the end of the brackets.

Desktop Mounting Dimensions

The following figures show the desktop mounting dimensions for the CMS/MMS-9068.

Figure 10. CMS/MMS-9068 Desktop Mounting Front Dimensions

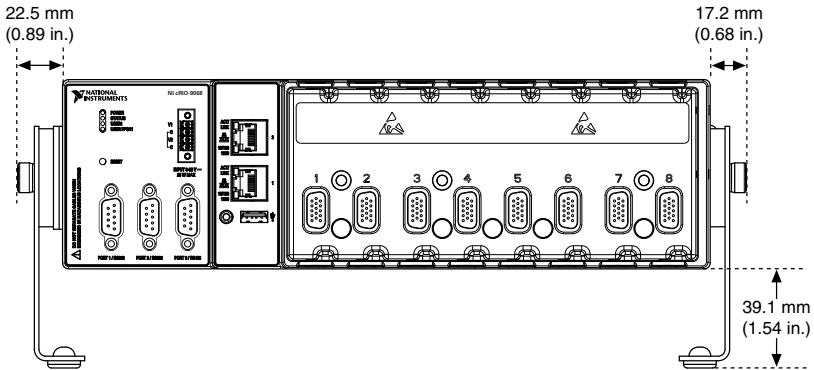
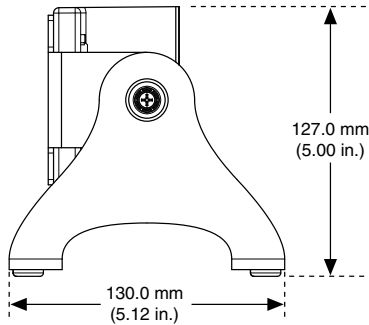

Figure 11. CMS/MMS-9068 Desktop Mounting Side Dimensions



Installing C Series I/O Modules in the Chassis



Note Before you install a C Series I/O module in the chassis, ensure that no I/O-side power is connected to the module. If the system is in a nonhazardous location, the chassis power can be on when you install modules.

Complete the following steps to install a C Series I/O module in the chassis.

1. Align the module with a slot in the chassis, as shown in the following figure. The module slots are labeled 1 to 8, left to right.



Note NI InsightCM device firmware requires that you install certain types of modules in certain slots. Refer to the [I/O Module Arrangements](#) section of this document for a list of supported modules and corresponding chassis slots.

Figure 12. Installing a C Series I/O Module in the Chassis

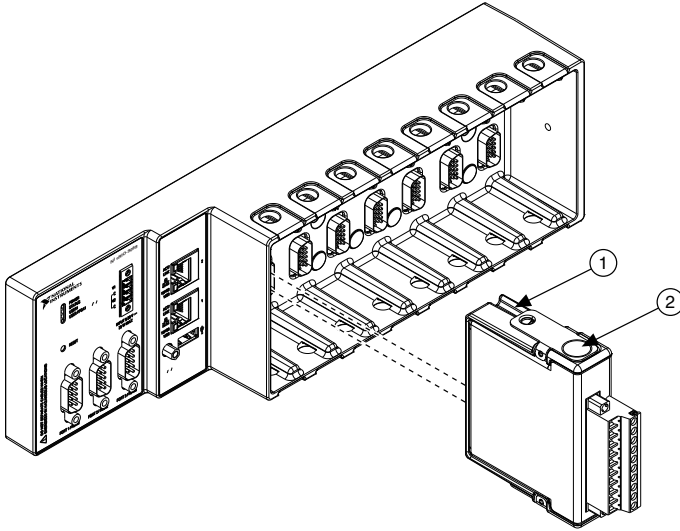

1. Insertion groove
2. Latch

2. Squeeze the latches and insert the module into the slot.
3. Press firmly on the connector side of the module until the latches lock the module into place.
4. Repeat these steps to install additional modules.

I/O Module Arrangements

NI InsightCM Server requires static and dynamic C Series I/O modules installed in a specific arrangement on the CMS/MMS-9068. The following table lists the module types you can install in slots under the four different arrangements that NI InsightCM Server supports.

Table 1. CMS/MMS-9068 I/O Module Arrangements

CMS/MMS-9068 Slot Number	Supported Arrangements				
	CMS Arrangement 1	CMS Arrangement 2	CMS Arrangement 3	CMS Arrangement 4	MMS Arrangement
1	Static	Dynamic	Dynamic	Dynamic	NI 9242
2	Static	Dynamic	Dynamic	Dynamic	NI 9239
3	Static	Static	Dynamic	Dynamic	NI 9239
4	Static	Static	Dynamic	Dynamic	NI 9239
5	Static	Static	Dynamic	Dynamic	NI 9239

Table 1. CMS/MMS-9068 I/O Module Arrangements (Continued)

CMS/MMS-9068 Slot Number	Supported Arrangements				
	CMS Arrangement 1	CMS Arrangement 2	CMS Arrangement 3	CMS Arrangement 4	MMS Arrangement
6	Static	Static	Dynamic	Dynamic	NI 9239
7	Static	Static	Static	Dynamic	NI 9239
8	Static	Static	Static	Dynamic	NI 9239



Note You do not need to fill every slot in the chassis. Fill the slots in order following the arrangements in Table 1.

Arrangements with Dynamic Modules

If the arrangement contains any dynamic input modules, such as the NI 9232, install those modules in adjacent slots beginning with slot 1. You must fill at least slot 1. After slot 1, fill module slots in ascending order.

For example, if the CMS/MMS-9068 arrangement contains NI 9232 dynamic input modules and NI 9205 and NI 9425 static input modules, install the modules in the order shown in the following table:

Table 2. Example CMS/MMS-9068 Arrangement

CMS/MMS-9068 Slot Number	Module Installed	Module Type
1	NI 9232	Dynamic
2	NI 9232	Dynamic
3	NI 9232	Dynamic
4	NI 9232	Dynamic
5	NI 9232	Dynamic
6	NI 9232	Dynamic
7	NI 9205	Static
8	NI 9425	Static

Arrangements with Only Static Modules

If the arrangement contains only static modules, install the modules in adjacent slots beginning with slot 1. You must fill at least slot 1. After slot 1, fill module slots in ascending order.

For example, if the CMS/MMS-9068 arrangement contains NI 9205, NI 9207, NI 9211, NI 9213, NI 9229, NI 9239, and NI 9425 static input modules, install the modules in the order shown in the following table:

Table 3. Example CMS/MMS-9068 Arrangement

CMS/MMS-9068 Slot Number	Static Module Installed
1	NI 9205
2	NI 9207
3	NI 9211
4	NI 9213
5	NI 9229
6	NI 9239
7	NI 9425
8	Empty

Removing I/O Modules from the Chassis



Note Before you remove a C Series I/O module from the chassis, ensure that no I/O-side power is connected to the module. If the system is in a nonhazardous location, the chassis power can be on when you install modules.

To remove a C Series I/O module from the chassis, squeeze the latches on both sides of the module and pull the module from the chassis.

Connecting to a Network

Use a standard Category 5 (CAT-5) or better shielded, twisted-pair Ethernet cable to connect the RJ-45 Ethernet port on the cRIO-9068 to an Ethernet hub.



Caution To prevent data loss and to maintain the integrity of your Ethernet installation, do not use a cable longer than 100 m.

The first time you power up the cRIO-9068, it attempts to initiate a DHCP network connection. If the cRIO-9068 cannot initiate a DHCP connection, it connects to the network with a link-local IP address with the form 169.254.x.x. After the chassis powers up, refer to [Resetting the Network Configuration of the NI InsightCM cRIO Controller](#).

Grounding the Chassis

Complete the following steps to connect the chassis grounding terminal to the grounding electrode system of your facility.

1. Attach a ring lug to a 2.0 mm² (14 AWG) or larger wire.
2. Remove the grounding screw from the grounding terminal on the right side of the chassis.
3. Attach the ring lug to the grounding terminal.

4. Tighten the grounding screw to 0.5 N · m (4.4 lb · in.) of torque.
5. Attach the other end of the wire to the grounding electrode system of your facility using a method appropriate for the application.



Note If you use shielded cabling to connect to a C Series I/O module with a plastic connector, attach the cable shield to the chassis grounding terminal using 1.3 mm² (16 AWG) or larger wire. Attach a ring lug to the wire and attach the wire to the chassis grounding terminal. Solder the other end of the wire to the cable shield. Use shorter wire for better EMC performance.

For more information about ground connections, visit ni.com/info and enter the Info Code `emcground`.

Wiring Power to the Controller

The cRIO-9068 requires an external power supply that meets device specifications. The cRIO-9068 filters and regulates the supplied power and provides power for all I/O modules installed in the chassis. The cRIO-9068 has one layer of reverse-voltage protection.

The following figure shows the terminal screws, which secure the wires in the screw terminals, and the connector screws, which secure the power connector on the front panel.

Figure 13. COMBICON Power Connector

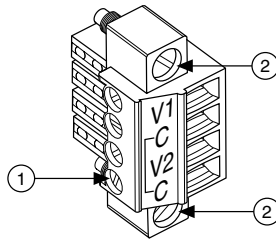

1. Terminal screws
2. Connector screws

Complete the following steps to connect a power supply to the chassis.

1. Connect the positive lead of the power supply to the V1 or V2 terminal of the COMBICON power connector installed on the front panel of the cRIO-9068 and tighten the terminal screw.
2. Connect the negative lead of the power supply to one of the C terminals of the power connector and tighten the terminal screw.
3. Optionally, connect the positive lead of another power supply to the other V terminal and the negative lead to one of the C terminals.

4. Tighten the connector screws.



Note If you connect power to both the V1 and V2 terminals, ensure that the voltage difference between the two power inputs, measured at the controller power connector, is at least 500 mV.



Note The controller draws power from either the V1 or V2 terminals depending on which terminal has a higher voltage. The controller does not draw power from both terminals. The controller switches between the V1 and V2 terminals without affecting operation.



Caution The C terminals are internally connected to each other. If you use two power supplies, ensure that they share a common ground.



Caution The C terminals are internally connected to the controller to prevent a faulty ground connection from causing the chassis ground to float. If you reverse the input voltage, the positive input voltage is connected directly to the chassis. The controller provides built-in reversed-voltage protection, but reversed voltage can damage connected peripherals if the chassis ground is not reliably connected to earth ground.



Caution Do not tighten or loosen the terminal screws on the power connector while the power connector is plugged in to the controller or while the power supply is on.

Powering On the Controller

When you apply power to the CompactRIO system, the controller runs a power-on self test (POST). The Power and Status LEDs turn on briefly. When the Status LED turns off, the POST is complete. If the LEDs do not behave in this way when the system powers on, refer to the information in this document about understanding LED indications.

Understanding LED Indications on the Controller

The following figure shows the LEDs on the cRIO-9068.

Figure 14. LEDs on the cRIO-9068

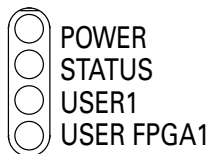

POWER LED

The POWER LED is lit while the cRIO-9068 is powered on. This LED indicates that the power supply connected to the controller is adequate.

STATUS LED

The STATUS LED is off during normal operation. After the device powers on, the cRIO-9068 indicates specific error conditions by flashing the STATUS LED a certain number of times every few seconds. If you observe this behavior after the device powers on, contact NI support.

USER1 LED

The USER1 LED can display the indications described in the following table:

Table 4. USER1 LED Indications

Indication	Description
Flashing rapidly	Indicates an error condition. Open InsightCM Systems Manager to the Dashboard page to see the device status.
Flashing steadily	Indicates normal operation.
Solid	Indicates that USB operations are in progress, such as reading or writing the connection information file. You can safely remove the USB drive when this LED resumes blinking steadily.  Note This device polls USB drives every 15 seconds, so you might need to wait up to 15 seconds after a USB operation begins for the LED to light.

USER FPGA1 LED

NI Condition Monitoring Systems do not use the USER FPGA1 LED.

Troubleshooting Network Communication

If the CMS/MMS-9068 does not connect to NI InsightCM Server with a status of Online, try the following troubleshooting tips:

- Check the Ethernet cable connections on the CMS/MMS-9068, host computer, and router.
- If you have network firewalls or other security software enabled, try temporarily turning them off. You might also need to add an exception for NI InsightCM Server by completing the following steps:
 1. Navigate to the standard Microsoft Windows Control Panel utility for managing firewall settings.
 2. Click **Allow a program or feature through Windows Firewall**.

3. Click **Allow another program**.
 4. Select **NI InsightCM** and click **Add**.
 5. Click **OK** and close the firewall settings.
- Ensure that the ports listed in the following table are open to communication on the host computer. If you are using an intelligent switch on the network, ensure that the switch is not disabling these ports.

Table 5. Host Computer Ports That Must Remain Open

Port	Type
5353	UDP (inbound and outbound rules)
6342	TCP (inbound and outbound rules)
81/443	TCP (outbound rule)

- If you have multiple network cards on the host computer, ensure that you use the Windows Control Panel to disable all other network adapters, such as wireless adapters. Turning off the wireless antenna is insufficient.

Resetting the Network Configuration of the Controller

Complete the following steps to reset the IP address and connection type of the controller.

1. Insert the USB drive into the USB port on the controller front panel. Within 20 seconds, the USER1 LED lights solid, which indicates that the device is reading from or writing to the settings file.



Tip You can use the blank USB drive included in the NI InsightCM Server kit, if available.

2. Remove the USB drive when the USER1 LED returns to blinking steadily.
3. Insert the USB drive into a USB port on a computer.
4. Browse the file structure of the drive to the `\InsightCM\download\NI-cRIO-ModelNumber-SerialNumber` directory.
5. To view the current IP address, skip to step 6. To change the IP address or set the IP address to be static, copy the JSON file beginning with `networkInfo_` followed by the device hostname, such as `networkInfo_NI-cRIO-ModelNumber-SerialNumber.json`, to the `\InsightCM\upload` directory on the USB drive. You might need to create the `upload` folder.
6. Open the JSON file beginning with `networkInfo_` followed by the device hostname.
7. In the array that contains the line `"IsPrimary": true`, the following line displays the current IP address:

```
"IP Address": "x.x.x.x"
```

where `x.x.x.x` is the desired IP address.

8. To change the IP address, enter the desired value. Otherwise, record the IP address.

9. (Optional) To assign a static IP address, configure the following line in the array as shown:

```
"IP Address Request Mode": "1"
```
10. Save and close the file.
11. If you made changes to the file, insert the USB drive back into the USB port on the controller front panel. The USER1 LED lights solid, which indicates that the device is reading network and connection properties. You can remove the USB drive when the USER1 LED returns to blinking steadily.



Tip To verify that the device successfully applied changes you made to the file, reinsert the USB drive in a computer and browse to the `\InsightCM` directory. If the changes were successfully applied, the `upload` folder no longer contains the JSON file you edited, but instead a folder named `applied` now contains the file.

Where to Go Next

The following figure describes additional documentation and resources as you develop an application with the CMS/MMS-9068.

Figure 15. Where to Go Next

<p>1</p> <p><i>NI InsightCM™ Server Configuration and Monitoring Help</i></p>		<p>Help system with instructions for configuring NI InsightCM Server and monitoring NI Condition Monitoring Systems. To launch this help, open InsightCM Systems Manager in a web browser and click the Help link in the top-right corner of the page.</p>
<p>2</p> <p>CompactRIO Controller and Chassis Datasheets</p>		<p>Device specifications, including power requirements, physical characteristics, safety and environmental information, and other important information. Visit ni.com/manuals and search your device.</p>
<p>3</p> <p>C Series Module Documentation</p>		<p>Operating instructions and device specifications for C Series modules that you can install in a CompactRIO chassis. These documents describe how to connect sensors, actuators, and other devices to C Series modules. Visit ni.com/info and enter the Info Code <code>insightcmdocs</code> to access documentation for C Series modules that are compatible with NI InsightCM.</p>

Worldwide Support and Services

The NI website is your complete resource for technical support. At ni.com/support, you have access to everything from troubleshooting and application development self-help resources to email and phone assistance from NI Application Engineers.

Visit ni.com/services for NI Factory Installation Services, repairs, extended warranty, and other services.

Visit ni.com/register to register your NI product. Product registration facilitates technical support and ensures that you receive important information updates from NI.

NI corporate headquarters is located at 11500 North Mopac Expressway, Austin, Texas, 78759-3504. NI also has offices located around the world. For telephone support in the United States, create your service request at ni.com/support or dial 1 866 ASK MYNI (275 6964). For telephone support outside the United States, visit the *Worldwide Offices* section of ni.com/niglobal to access the branch office websites, which provide up-to-date contact information, support phone numbers, email addresses, and current events.

Refer to the *NI Trademarks and Logo Guidelines* at ni.com/trademarks for information on NI trademarks. Other product and company names mentioned herein are trademarks or trade names of their respective companies. For patents covering NI products/technology, refer to the appropriate location: **Help»Patents** in your software, the `patents.txt` file on your media, or the *National Instruments Patent Notice* at ni.com/patents. You can find information about end-user license agreements (EULAs) and third-party legal notices in the readme file for your NI product. Refer to the *Export Compliance Information* at ni.com/legal/export-compliance for the NI global trade compliance policy and how to obtain relevant HTS codes, ECCNs, and other import/export data. NI MAKES NO EXPRESS OR IMPLIED WARRANTIES AS TO THE ACCURACY OF THE INFORMATION CONTAINED HEREIN AND SHALL NOT BE LIABLE FOR ANY ERRORS. U.S. Government Customers: The data contained in this manual was developed at private expense and is subject to the applicable limited rights and restricted data rights as set forth in FAR 52.227-14, DFAR 252.227-7014, and DFAR 252.227-7015.

© 2014—2015 National Instruments. All rights reserved.

374691B-01 Oct15