

COMPREHENSIVE SERVICES

We offer competitive repair and calibration services, as well as easily accessible documentation and free downloadable resources.

SELL YOUR SURPLUS

We buy new, used, decommissioned, and surplus parts from every NI series. We work out the best solution to suit your individual needs.

 Sell For Cash  Get Credit  Receive a Trade-In Deal

OBSOLETE NI HARDWARE IN STOCK & READY TO SHIP

We stock **New**, **New Surplus**, **Refurbished**, and **Reconditioned** NI Hardware.



Bridging the gap between the manufacturer and your legacy test system.

 1-800-915-6216

 www.apexwaves.com

 sales@apexwaves.com

All trademarks, brands, and brand names are the property of their respective owners.

Request a Quote

 **CLICK HERE**

cRIO-9081

INSTALLATION INSTRUCTIONS

Rack Mounting Kit with DIN Rail for CompactRIO and CompactDAQ

Français Deutsch 日本語 한국어 简体中文
ni.com/manuals

The National Instruments CompactRIO rack mounting kit with DIN rail is an accessory you can use to mount a CompactRIO chassis and other DIN rail-mountable equipment on a standard 19-inch rack.



Note You need a #2 Phillips screwdriver to install the rack mounting kit.

The NI CompactRIO rack mounting kit with DIN rail contains the following components:

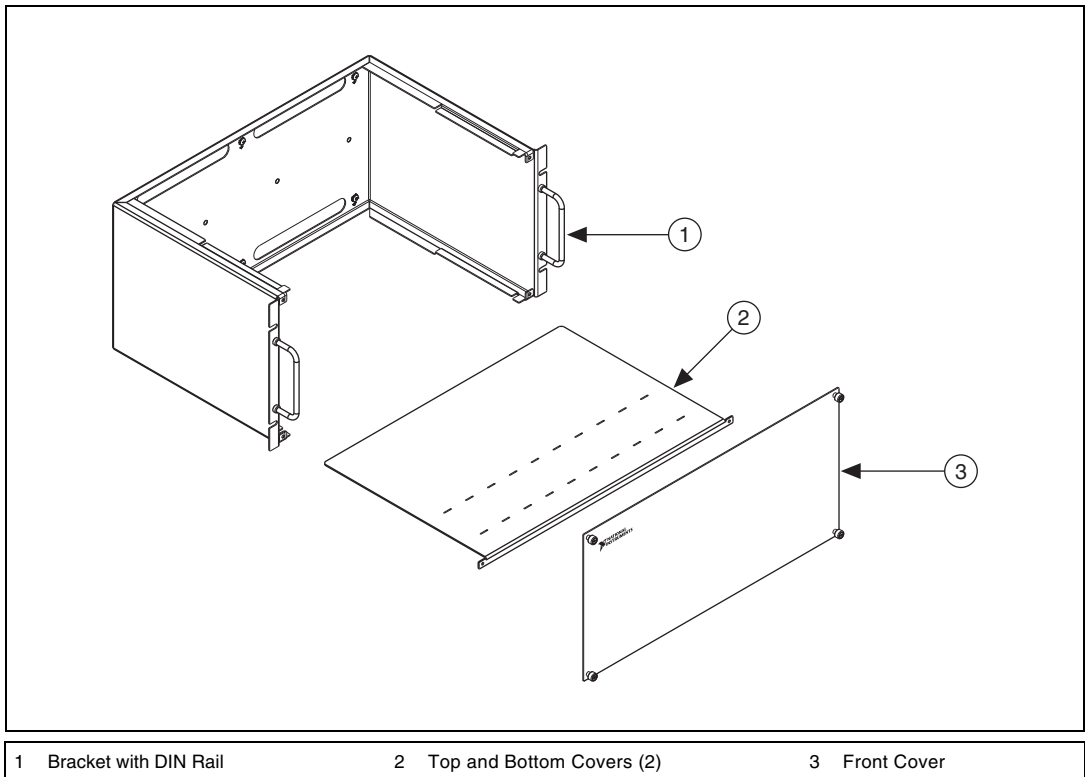

Figure 1. Components of the NI CompactRIO Rack Mounting Kit with DIN Rail

Installing the Rack Mounting Kit

Complete the following steps to install the rack mounting kit on a standard 19-inch rack:

1. Secure the bracket in position with four screws suitable for the rack. Screws are not included in the kit.



Note Do not overtighten the screws. You may need to adjust the screws when assembly is complete.

2. Install a DIN rail clip on the chassis using the screws shipped with the clip. Refer to the chassis documentation for information about installing the DIN rail clip. The following figure shows how to install the DIN rail clip that fits the NI cRIO-908x chassis.

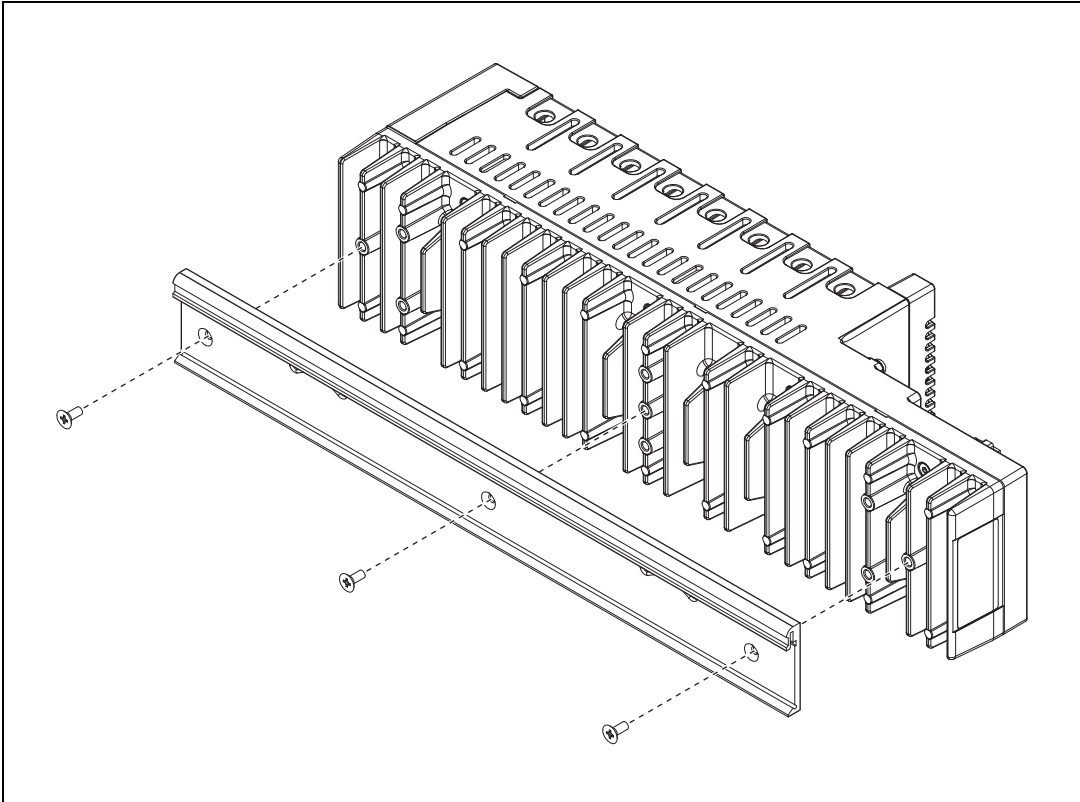

Figure 2. Installing a DIN Rail Clip on the NI cRIO-908x

- Clip the chassis and DIN rail clip assembly to the DIN rail, as shown in Figure 3.

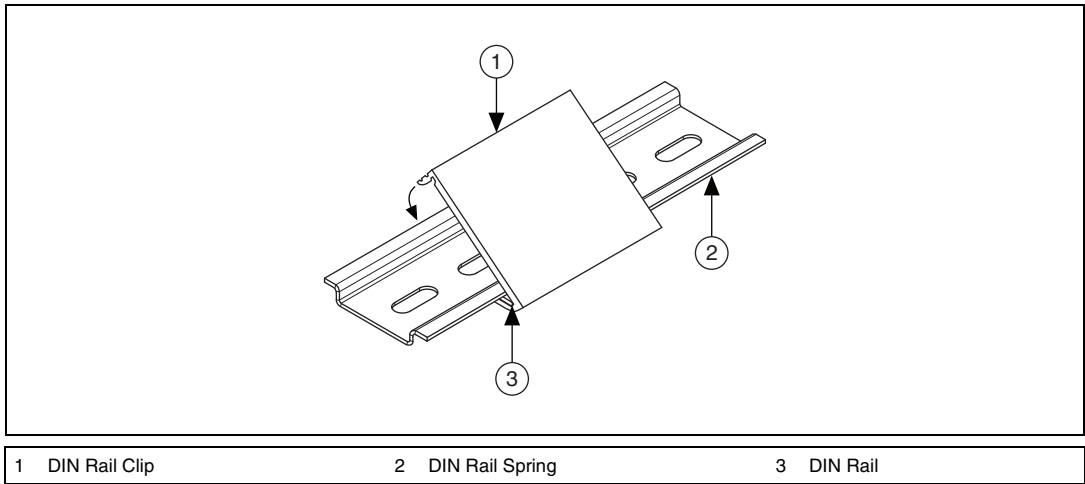

Figure 3. Attaching the DIN Rail Clip to the DIN Rail

- Make all necessary electrical connections as described in the controller, chassis, and I/O module documentation. Route all cables through the openings in rear surface of the bracket.
- Connect the chassis ground wire to the bracket grounding screw. Refer to Figure 5 for the location of the bracket grounding screw.
- Install the top and bottom covers as shown in Figure 4.

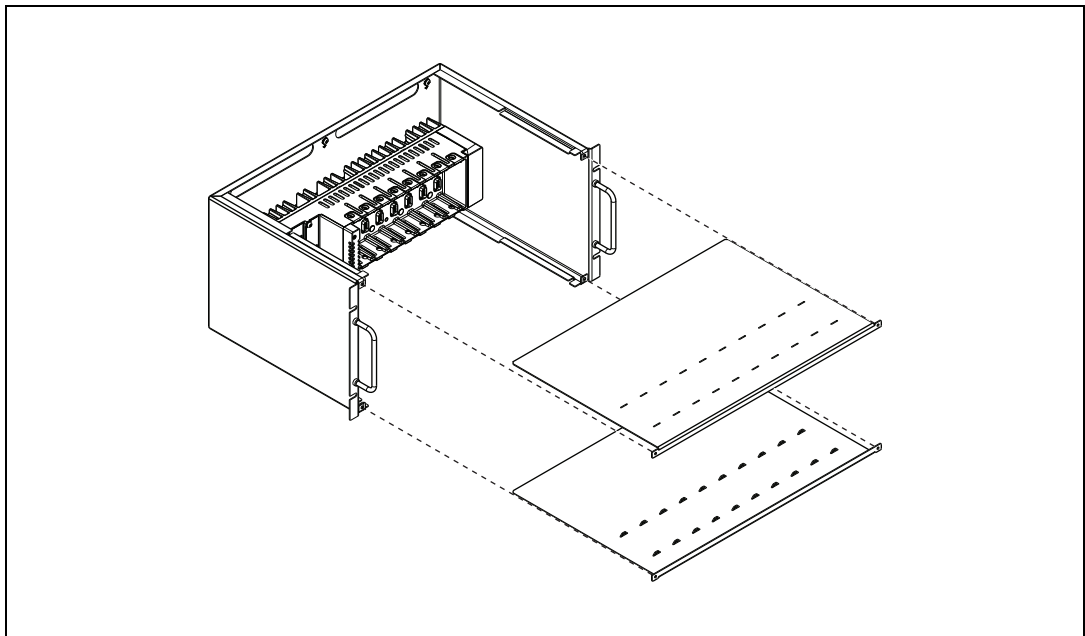

Figure 4. Installing the Top and Bottom Covers

7. Install cable ties (not included) to relieve strain on the cables if necessary. You can attach cable ties to the mounts on the top and bottom covers. Figure 5 does not show the top covers, but the top and bottom covers are identical.

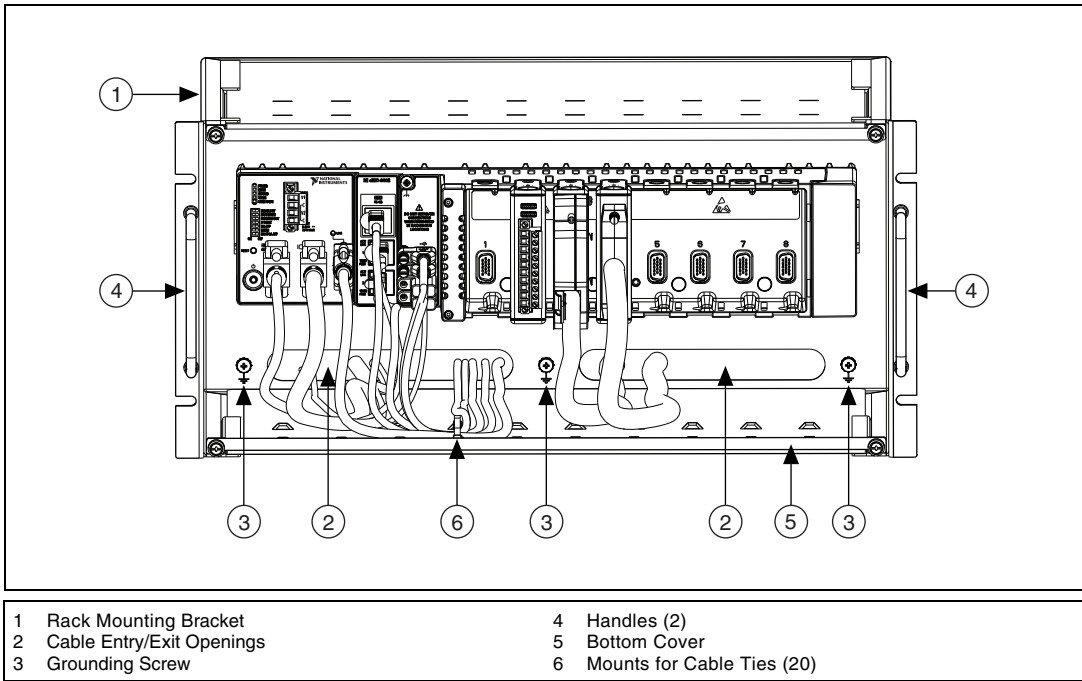

Figure 5. NI cRIO-908x Mounted in Bracket, Front View

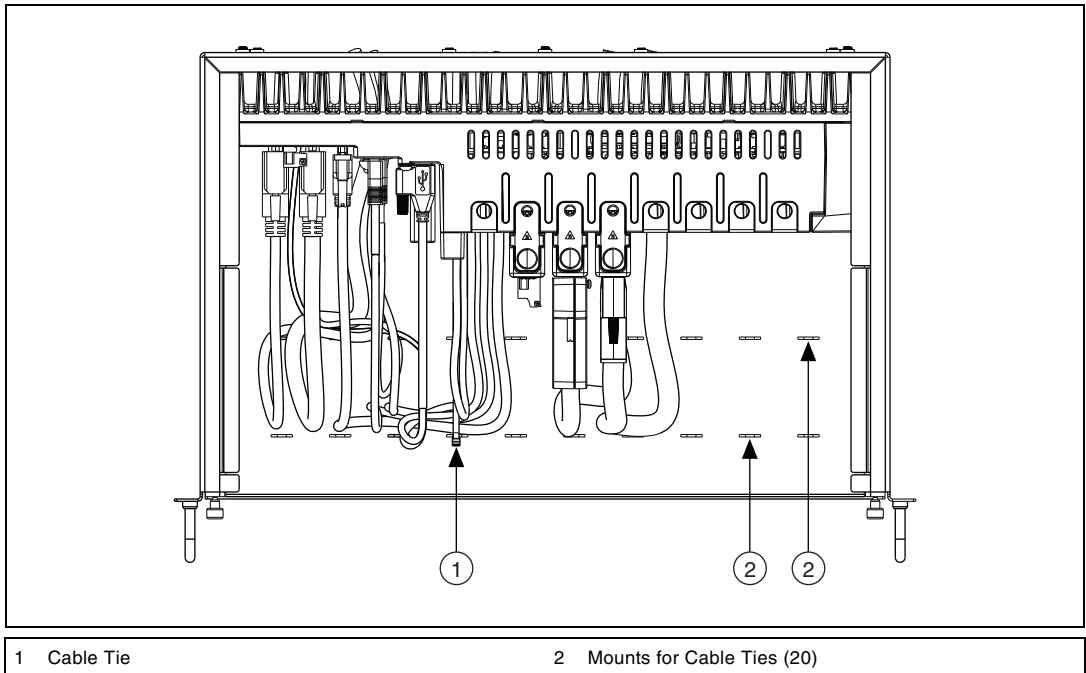

Figure 6. NI cRIO-908x Mounted in Bracket, Top View

8. Install the front cover as shown in Figure 7.

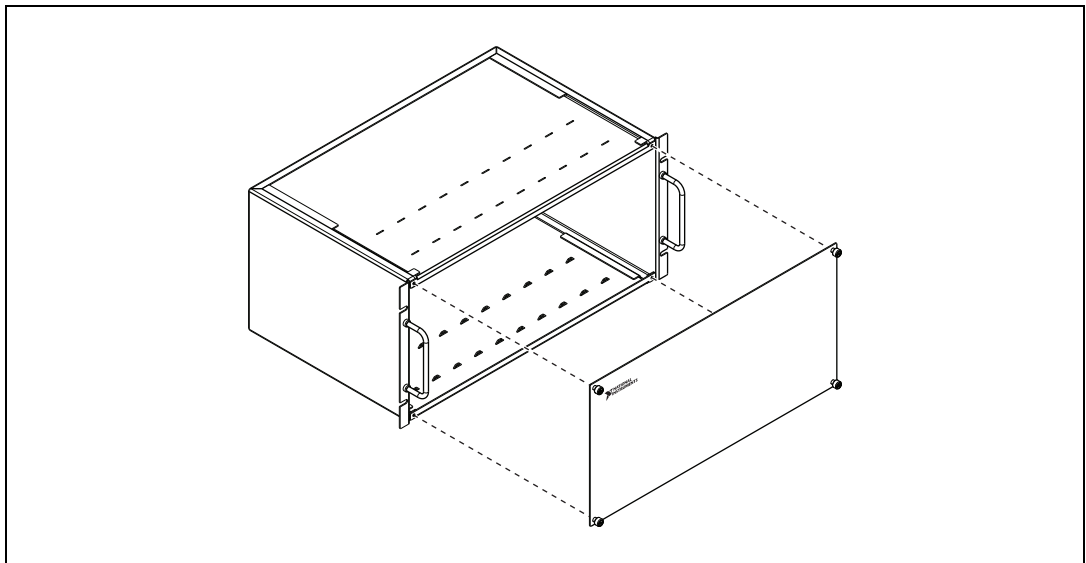

Figure 7. Installing the Front Cover

9. Tighten the four captive screws on the front cover. Do not tighten past $0.5 \text{ N} \cdot \text{m}$ ($4.9 \text{ lb} \cdot \text{in.}$) of torque.

The following figure shows the dimensions of the rack mounting kit.

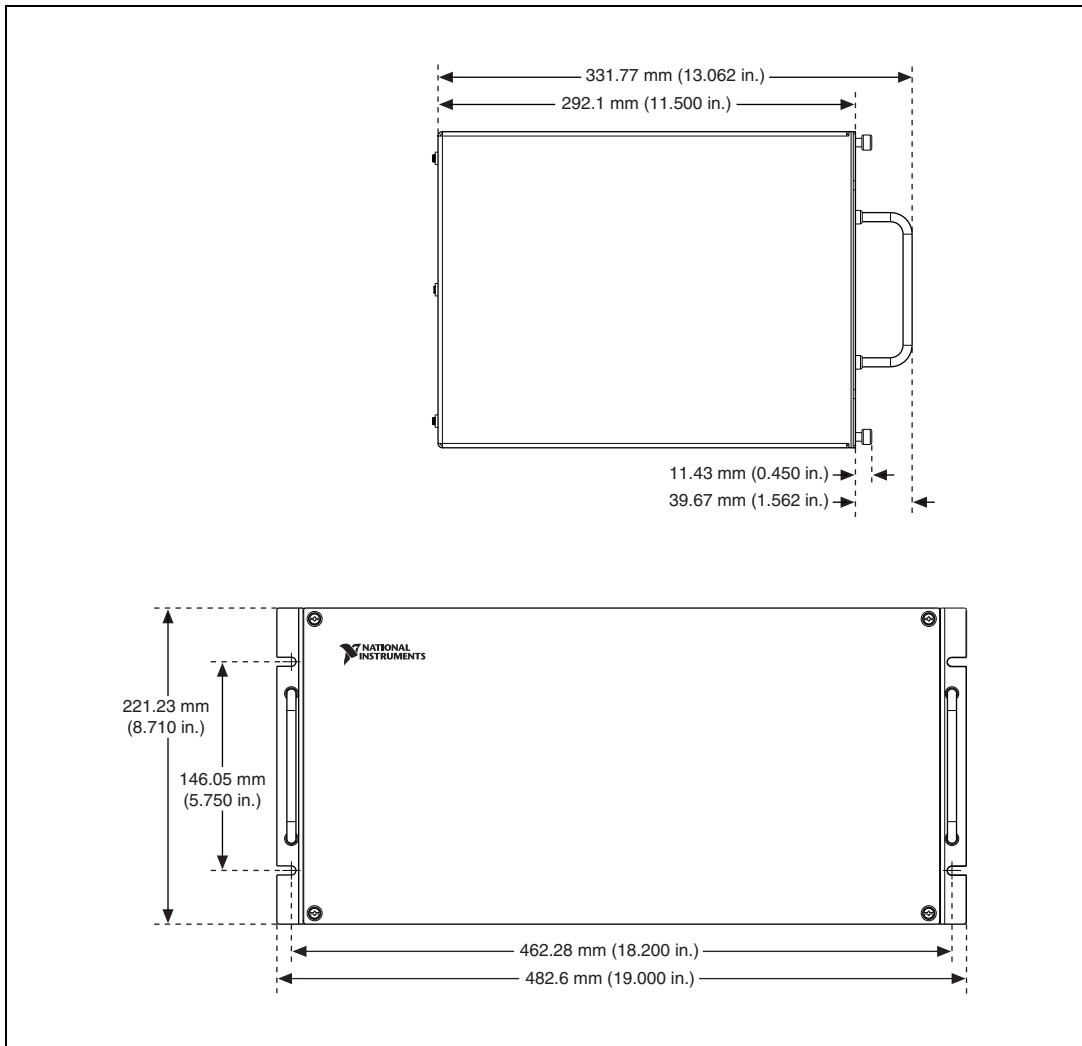

Figure 8. Dimensions of Rack Mounting Kit

Refer to the *NI Trademarks and Logo Guidelines* at ni.com/trademarks for more information on National Instruments trademarks. Other product and company names mentioned herein are trademarks or trade names of their respective companies. For patents covering National Instruments products/technology, refer to the appropriate location: **Help»Patents** in your software, the `patents.txt` file on your media, or the *National Instruments Patents Notice* at ni.com/patents. You can find information about end-user license agreements (EULAs) and third-party legal notices in the readme file for your NI product. Refer to the *Export Compliance Information* at ni.com/legal/export-compliance for the National Instruments global trade compliance policy and how to obtain relevant HTS codes, ECCNs, and other import/export data.